

Consejos de Conservación

1. No debe utilizarse en la limpieza, abrasivos como lana de acero, alcohol, limón, o productos corrosivos que puedan rayar o quitar la película en los muebles.
2. Cuando la limpieza de muebles en general, napa y formica, deben utilizarse un paño ligeramente humedecido y jabón suave.
3. Para mover el mueble, es importante que este se eleve desde el suelo, debido a que el arrastre puede causar daño estructural.
4. No deje el mueble en exposición a la intemperie.

Conservation Tips

1. Do not use abrasive products to clean such as steel wool, alcohol, vinegar, lemon, scouring powder, or corrosive products which can scratch or peel off the protective film of the furniture.
2. The best way to clean your furniture is to use a slightly moistened cloth with a mild soap.
3. To move the furniture assembled, it is important that it is lifted off the ground, because the drag it can cause structural damage.
4. Do not leave your furniture in weather exposure.

Dicas de conservação

1. Não utilizar na limpeza produtos abrasivos tais como: palha de aço, álcool, vinagre, limão, saponáceo ou produtos corrosivos que possam riscar ou descolar a película protetora dos móveis.
2. Na limpeza de móveis em geral, napa e fórmicas, deve ser utilizado um pano levemente umedecido e sabão neutro.
3. Para a movimentação do móvel, é importante que este seja levantado do chão, pois ao arrastá-lo pode causar avarias estruturais.
4. Não deixe o móvel em exposição a intempéries.

Conseils d'entretien

1. Ne pas utiliser de produits abrasifs dans le nettoyage, tels que: laine d'acier, alcool, vinaigre, citron, poudre à récurer ou autres produits corrosifs pouvant rayar ou faire décoller la pellicule protectrice des meubles.
2. Pour le nettoyage du meuble, il est recommandé d'utiliser un chiffon humide et du savon neutre.
3. Pour déplacer le meuble, il est important de le soulever du sol car le tirer pourrait causer des dommages dans sa structure.
4. Ne pas exposer le meuble aux intempéries.

LISTA DE PEÇAS / PARTS LIST / LISTA DE PEÇAS / LISTE DES PIÈCES

#	Cantidad Quantity Quantidade Quantité	Piezas	Pieces	Peças	Pièces	Dimensiones Dimension Dimensões Dimension
1	1	Tapa de la Mesa	Table Top Panel	Tampo Mesa	Dessus de la table	1200 x 444 x 15
2	1	Lateral de la Mesa	Table Side Panel	Lateral Mesa	Côté de la table	734 x 444 x 15
3	1	Marco Superior	Upper Frame	Moldura Superior	Cadre supérieur	1200 x 70 x 15
4	1	Marco Delantero	Front Frame	Moldura Frontal	Cadre avant	680 x 70 x 15
5	1	Marco Lateral	Side Frame	Moldura Lateral	Cadre latéral	429 x 54 x 15
6	1	Costado de la Mesa	Table Back Panel	Fechamento Traseiro	Table Coast	1184 x 200 x 15
7	1	Lateral Derecha	Right Side Panel	Lateral Direita Gaveteiro	Côté droit	665 x 400 x 15
8	1	Lateral Izquierda	Left Side Panel	Lateral Esquerda Gaveteiro	Côté Gauche	665 x 400 x 15
9	1	Tapa	Top Panel	Tampo Gaveteiro	Dessus de tiroir	400 x 400 x 15
10	1	Base	Base Panel	Base Gaveteiro	Base	369 x 400 x 15
11	2	Zócalo	Baseboard	Rodapé	Socle	369 x 70 x 15
12	2	Frente del Cajón	Drawer Front	Frente de Gaveta	Façade Tiroir	363 x 157 x 15
13	1	Costado	Back Panel	Costa Painel	Pièce Arrière	369 x 320 x 15
14	2	Costado del Cajón	Drawer Back Panel	Costa de Gaveta	Pièce ArrièreTiroir	320 x 100 x 12
15	2	Fondo del Cajón	Drawer Side Panel	Fundo de Gaveta	Côtés Droit et Gauche Tiroir	344 x 355 x 3
16	4	Lateral del Cajón	Side Drawer	Lateral de Gaveta	Côtés Droit et Gauche Tiroir	350 x 100 x 12

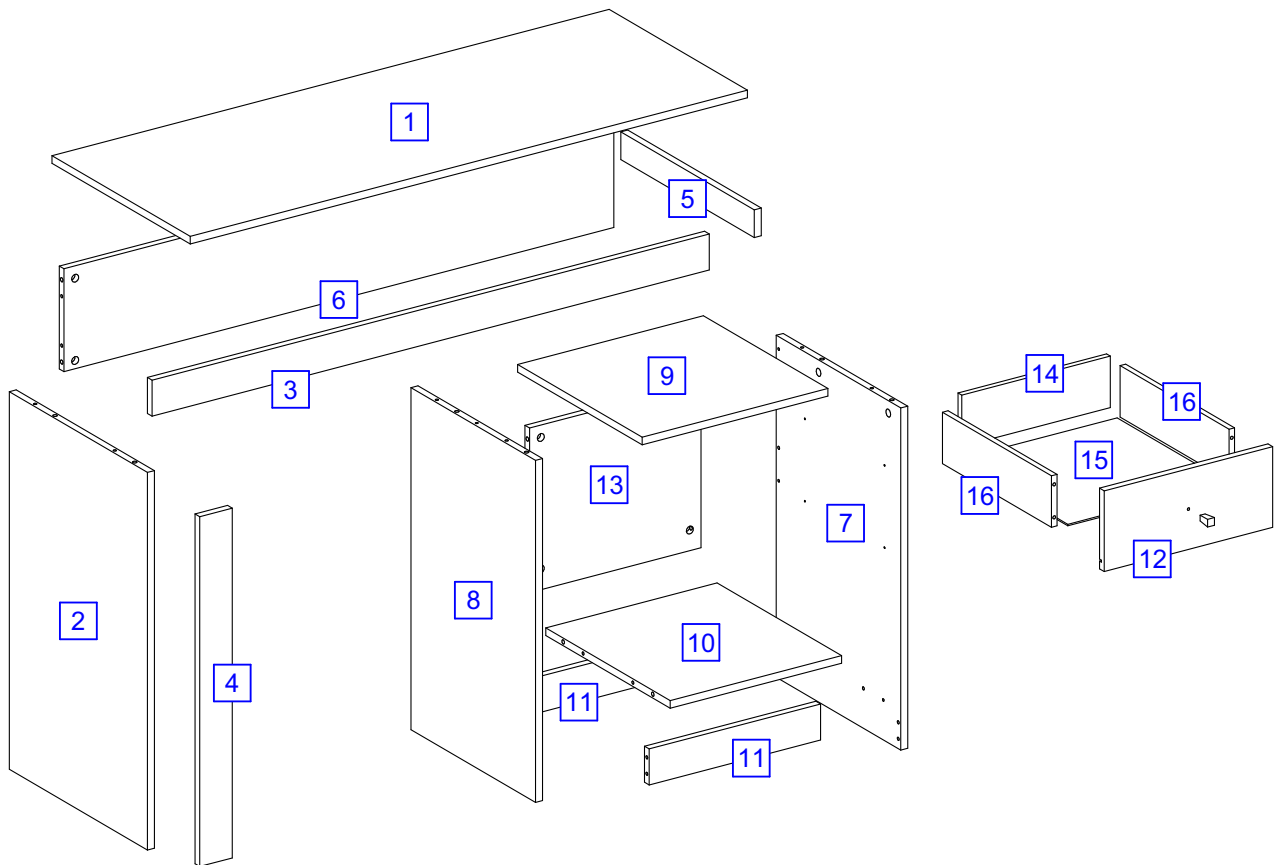

HERRAMIENTAS / HARDWARE FERRAMENTAS / OUTILS



PERSONAS NECESARIAS PARA EL MONTAJE PEOPLE REQUIRED FOR ASSEMBLY PESSOAS NECESSÁRIAS PARA A MONTAGEM NOMBRE DE PERSONNES NÉCESSAIRES À L'ASSEMBLAGE





A-88x

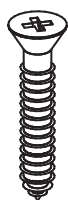

B-6x

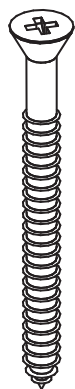

C-2x

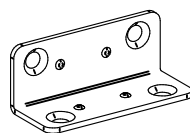

D-6x



E-10x

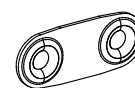

F-1X



G-32X

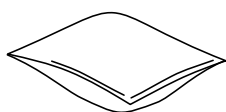

H-1X

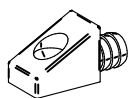

I-10x

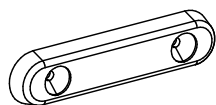

J-6x



K-16x

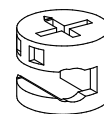

L-16x



M-28x

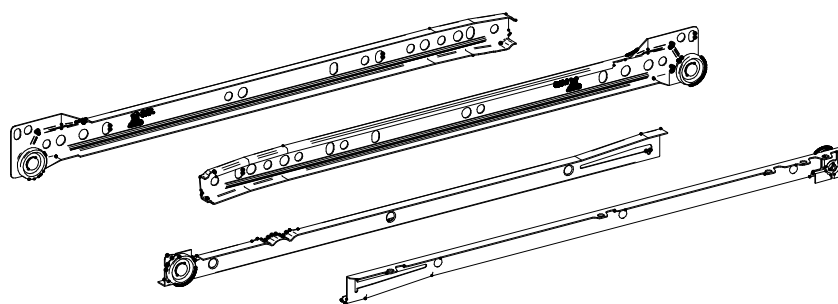

O-2x



N-10x

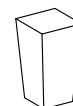

P-2x

1

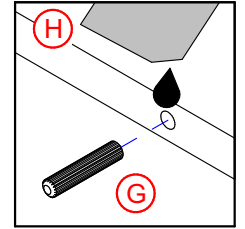
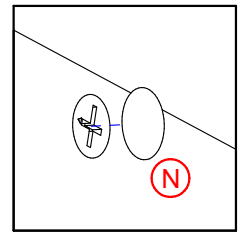
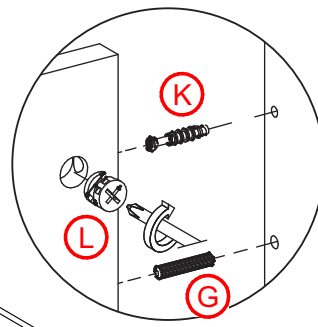
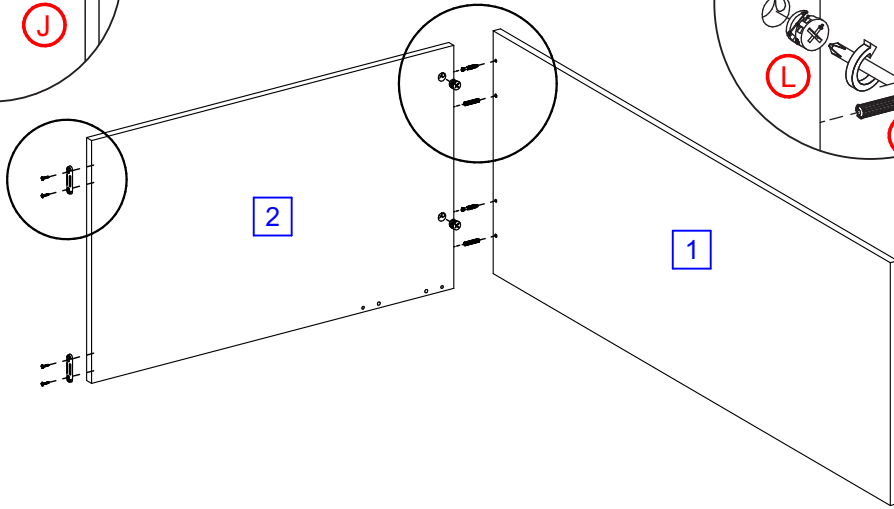
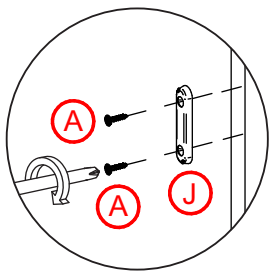

2

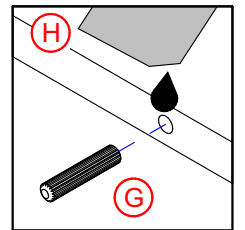
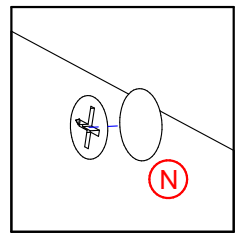
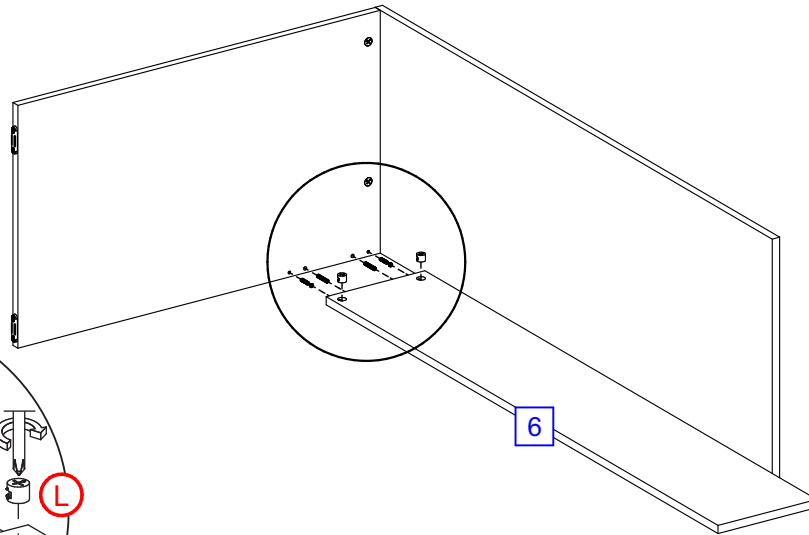
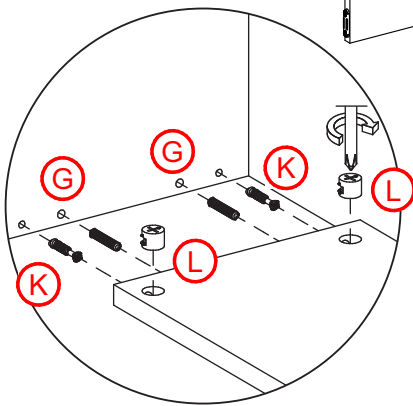

3

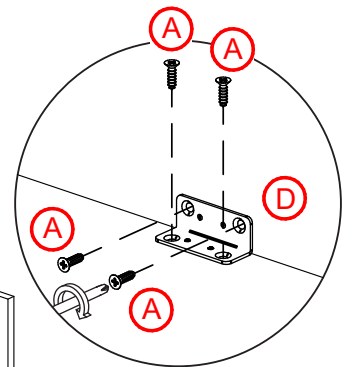
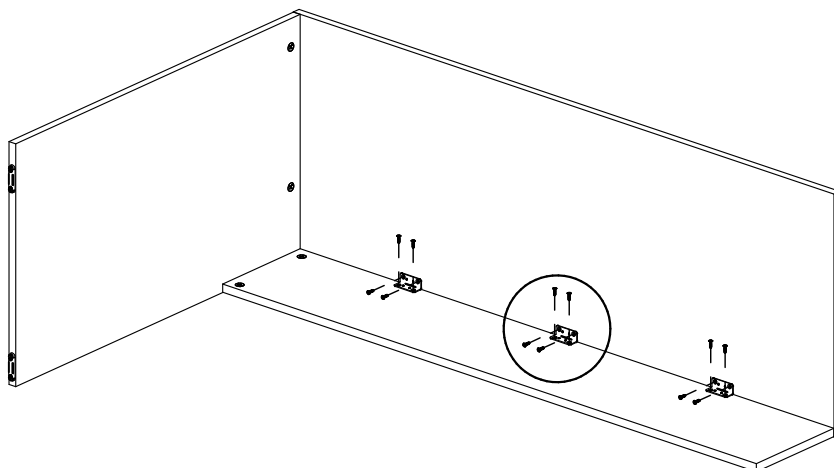

4

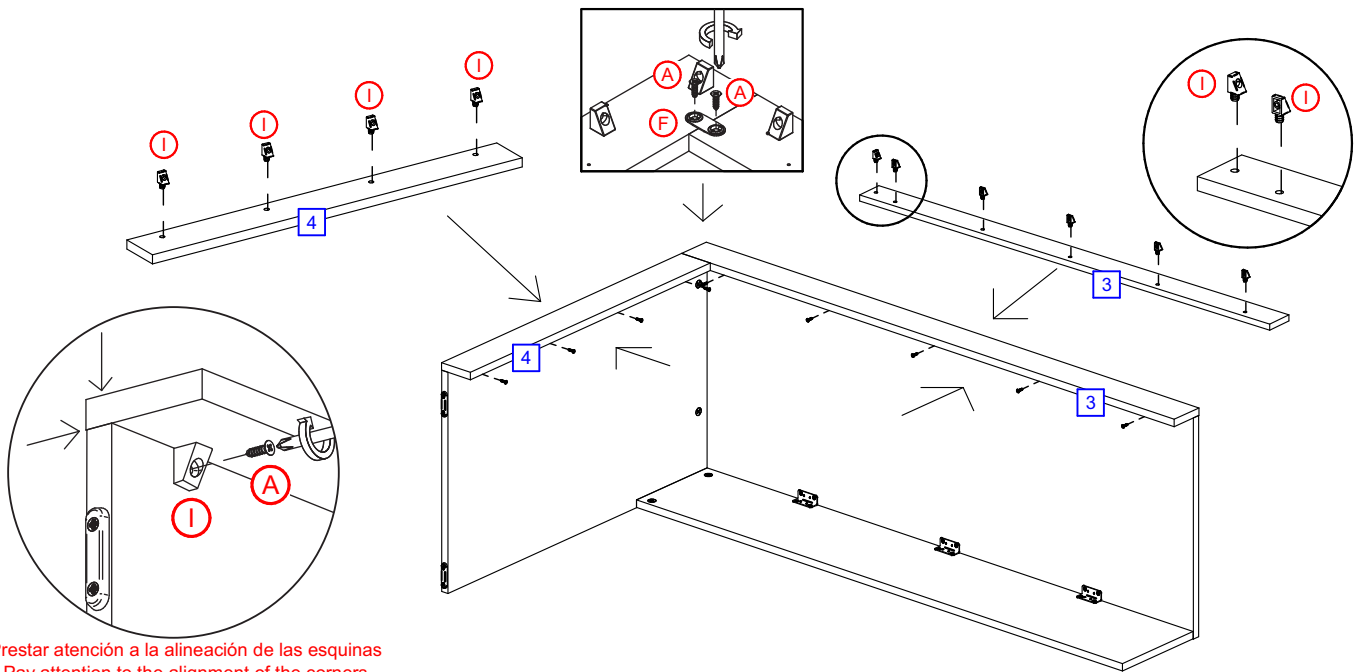

Prestar atención a la alineación de las esquinas
Pay attention to the alignment of the corners
Atentar para o alinhamento dos cantos
Faire attention à l'alignement des coins

5

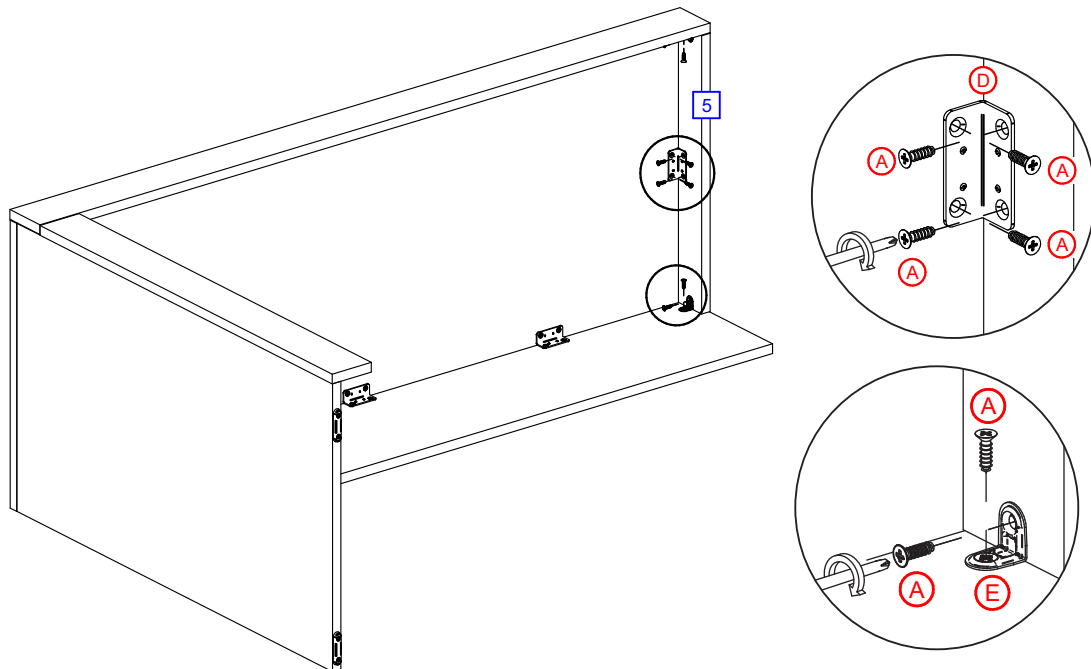

6

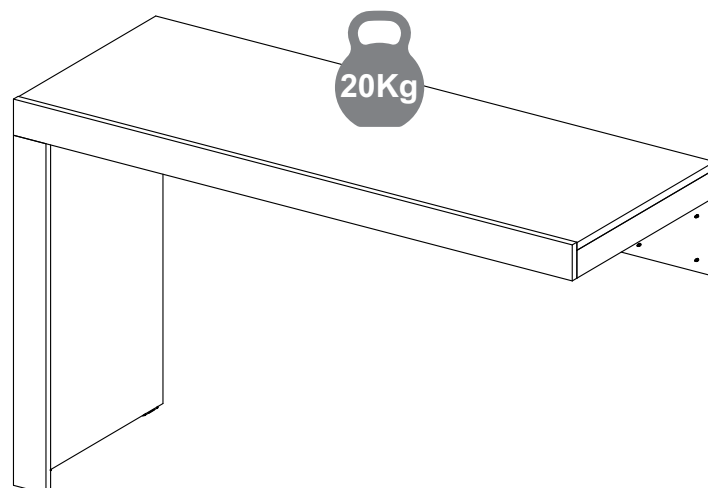

7

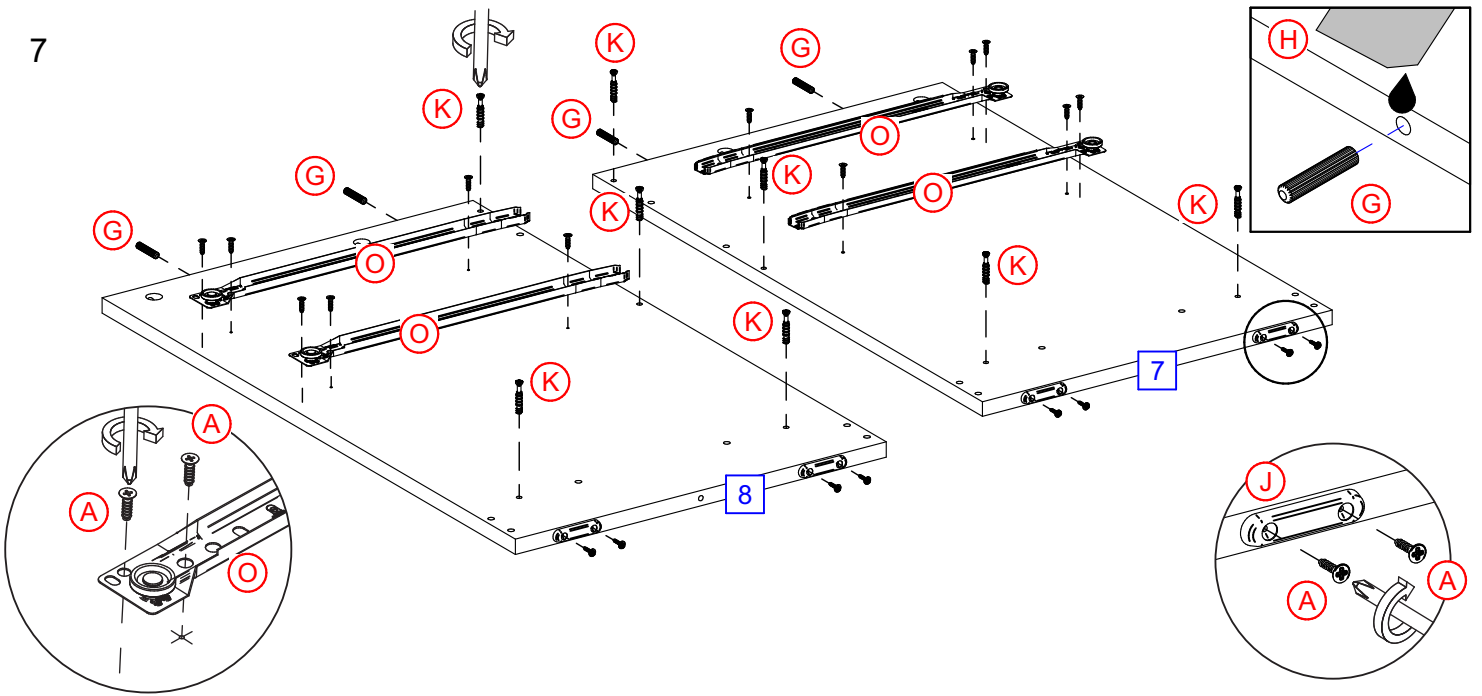

8

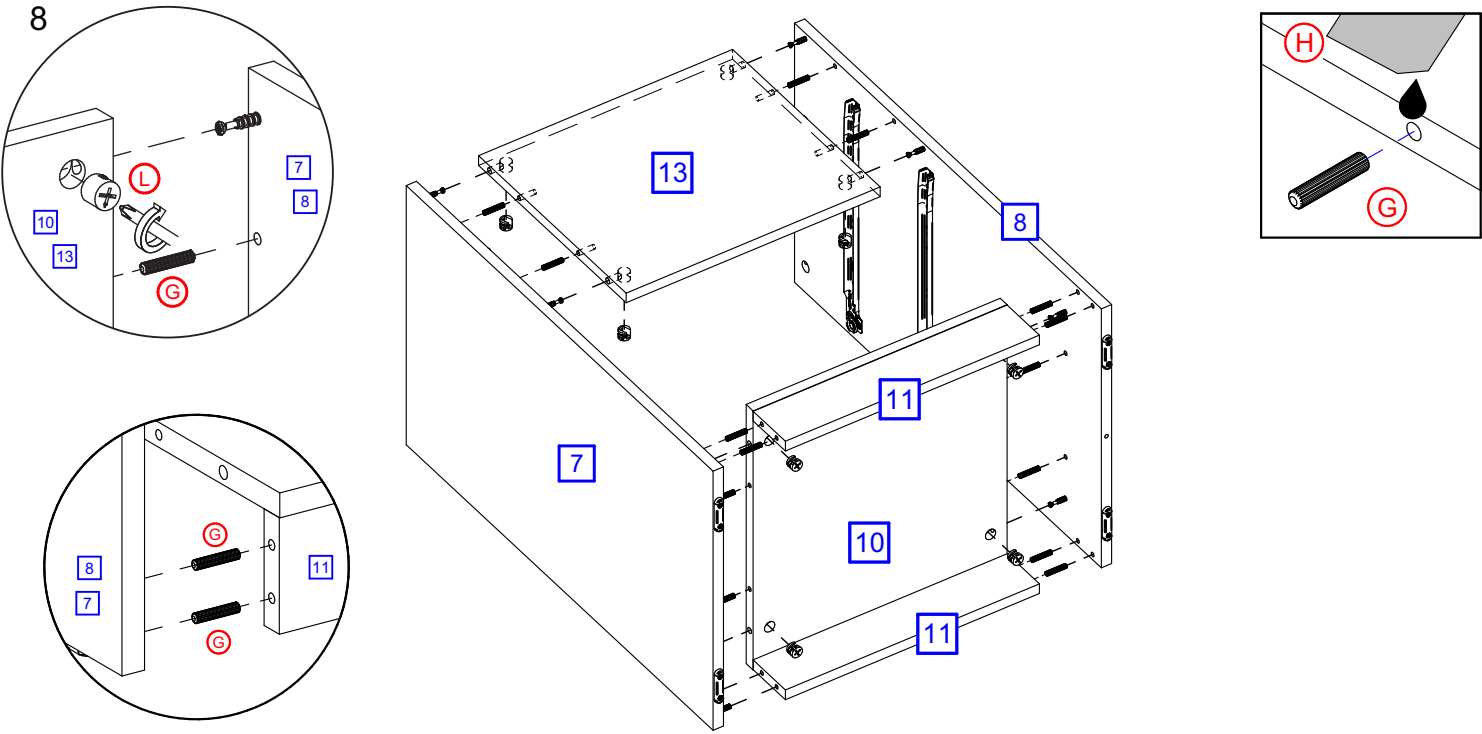

9

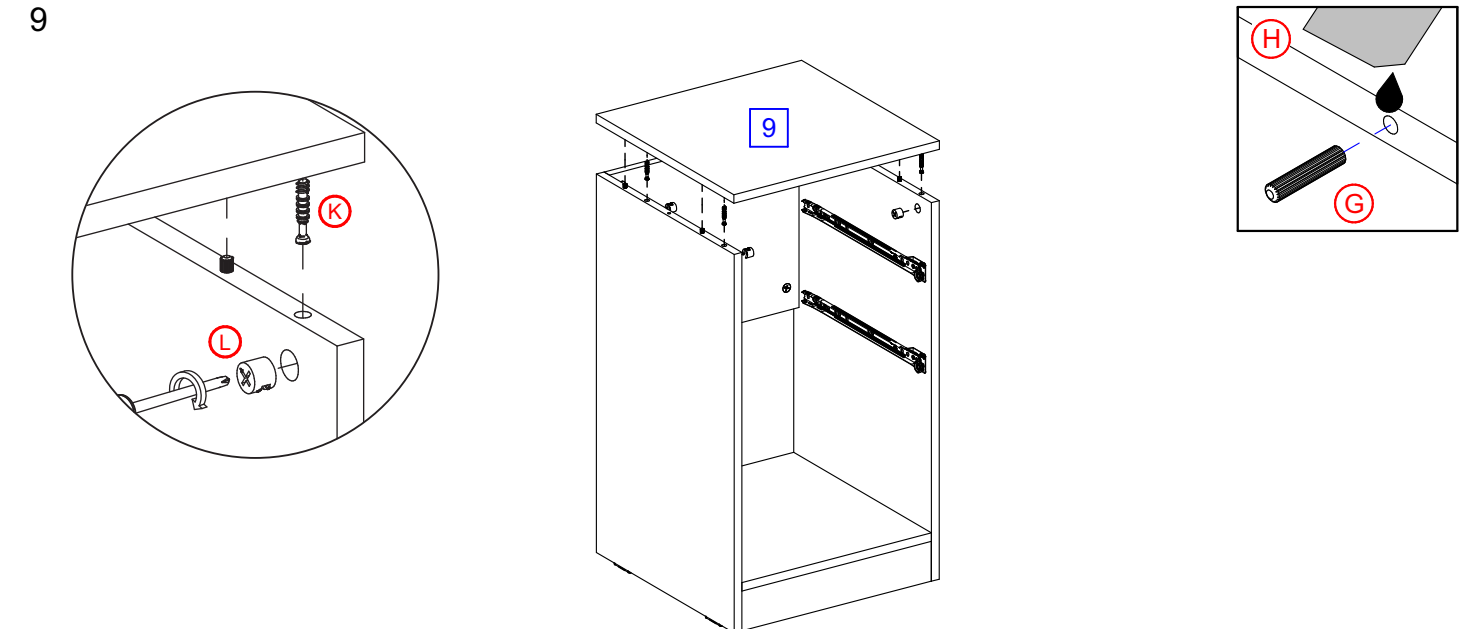

10 **2X**

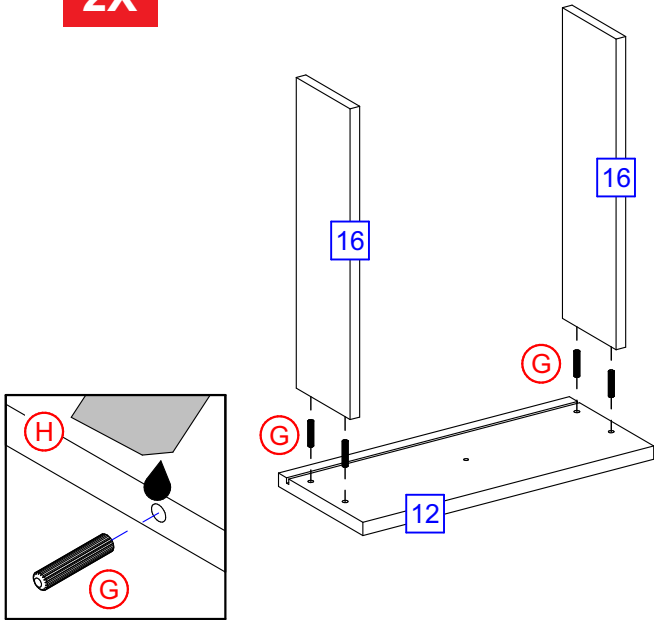

11 **2X**

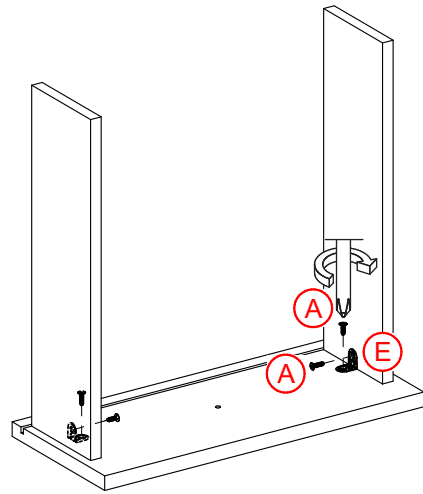

12 **2X**

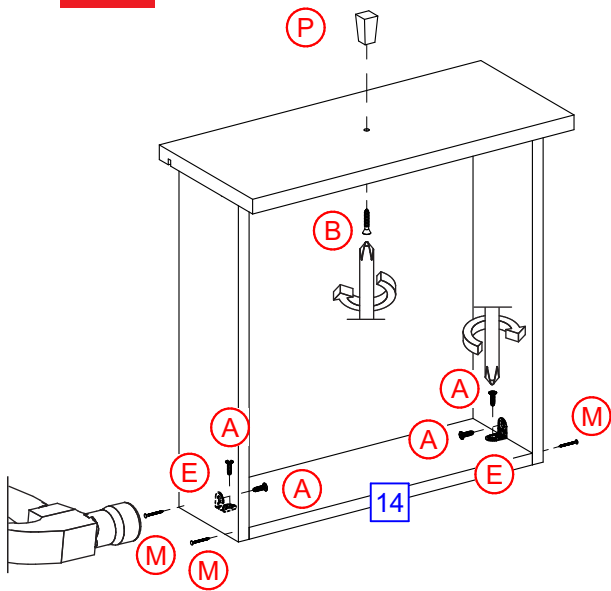

13 **2X**

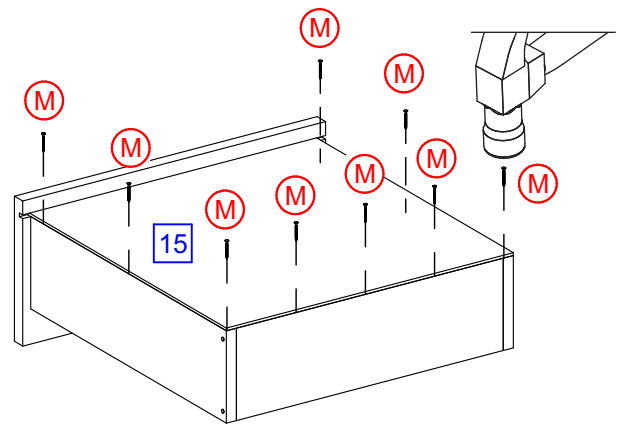

14 **2X**

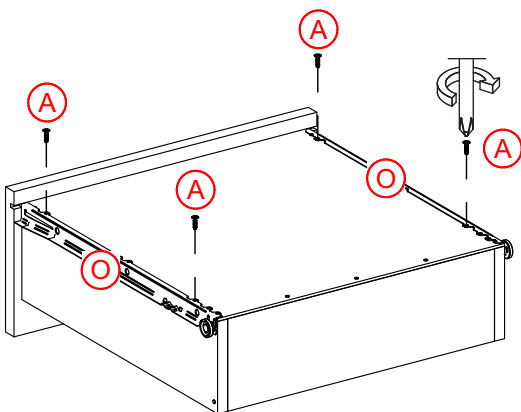

15 **2X**

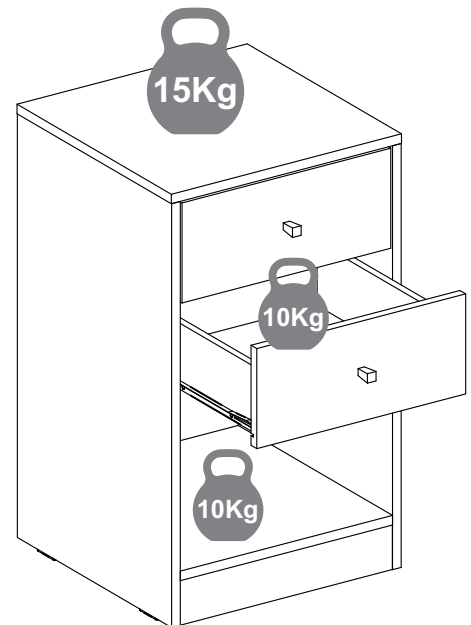

A)
 O produto pode ser fixado em outros produtos pelas costas, utilizando o parafuso "B".
 The product can be attached to other products from the back using the screw "B".
 El producto se puede fijar a otros productos a través de su costa, utilizando el tornillo "B".
 Le produit peut être fixé par la partie arrière en utilisant la vis "B".

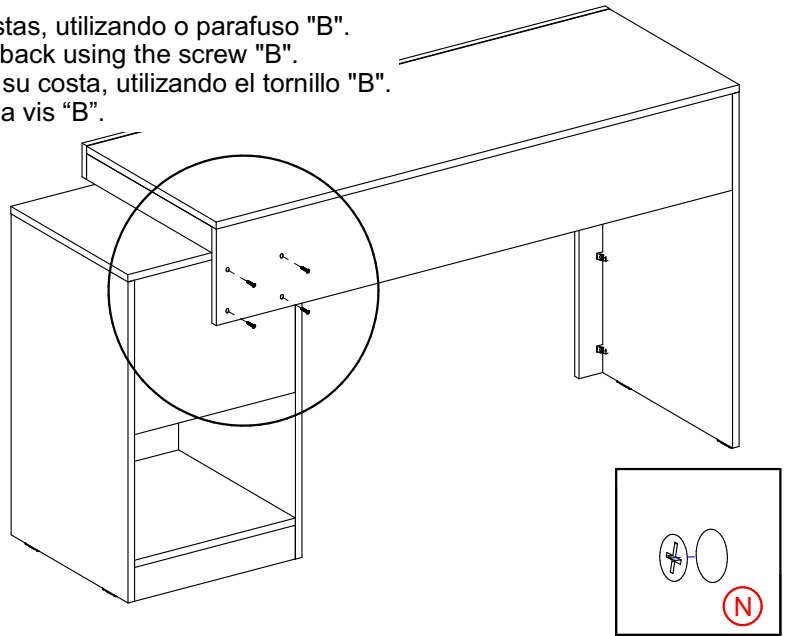
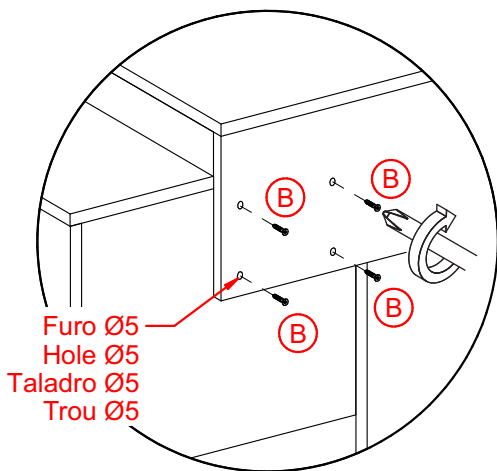

B)
 O produto pode ser fixado em tampos de outros produtos, utilizando um parafuso "C", de baixo para cima.
 The product can be fixed on tops of other products, using a screw "C", from bottom to top.
 El producto se puede fijar en la parte superior de otros productos, usando un tornillo "C", de abajo hacia arriba.
 Le produit peut être fixé sur la partie supérieure d'autres meubles en utilisant la vis "C", du bas vers le haut.

Prestar atención a la alineación
 Pay attention to the alignment
 Atentar para o alinhamento
 Faire attention à l'alignement

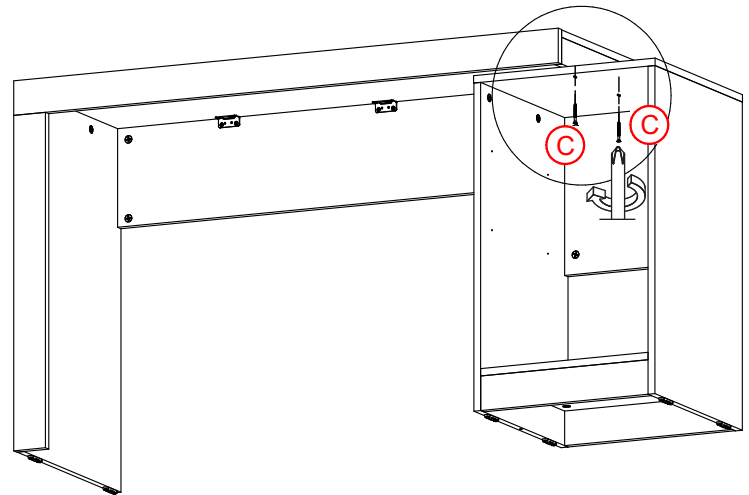
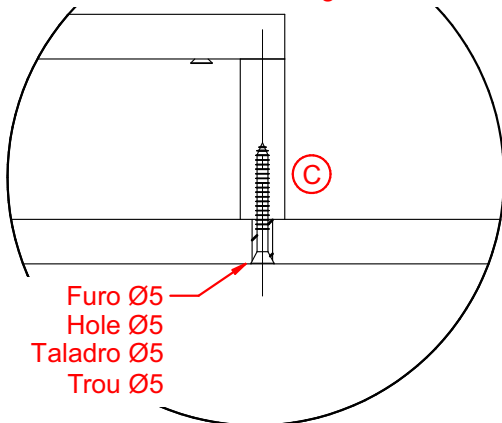

C)
 O produto pode ser fixado em outros móveis, utilizando parafusos e cantoneiras metálicas.
 The product can be fixed on other furniture, using screws and metal brackets.
 El producto se puede fijar en otros muebles, utilizando tornillos y soportes metálicos.
 Le produit peut être fixé sur d'autres meubles, en utilisant les vis et les équerres métalliques.

