

SKU N620P403783
N620P403784
N620P403785

Assembly Instruction

DE:Installationsanleitung

UK:Installation Instruction

FR:Instruction d'installation

IT:Istruzioni di installazione

ES: Instrucciones de instalación

NL: Installatie-instructies

SE: Installationsanvisningar

PL: Instrukcje instalacji

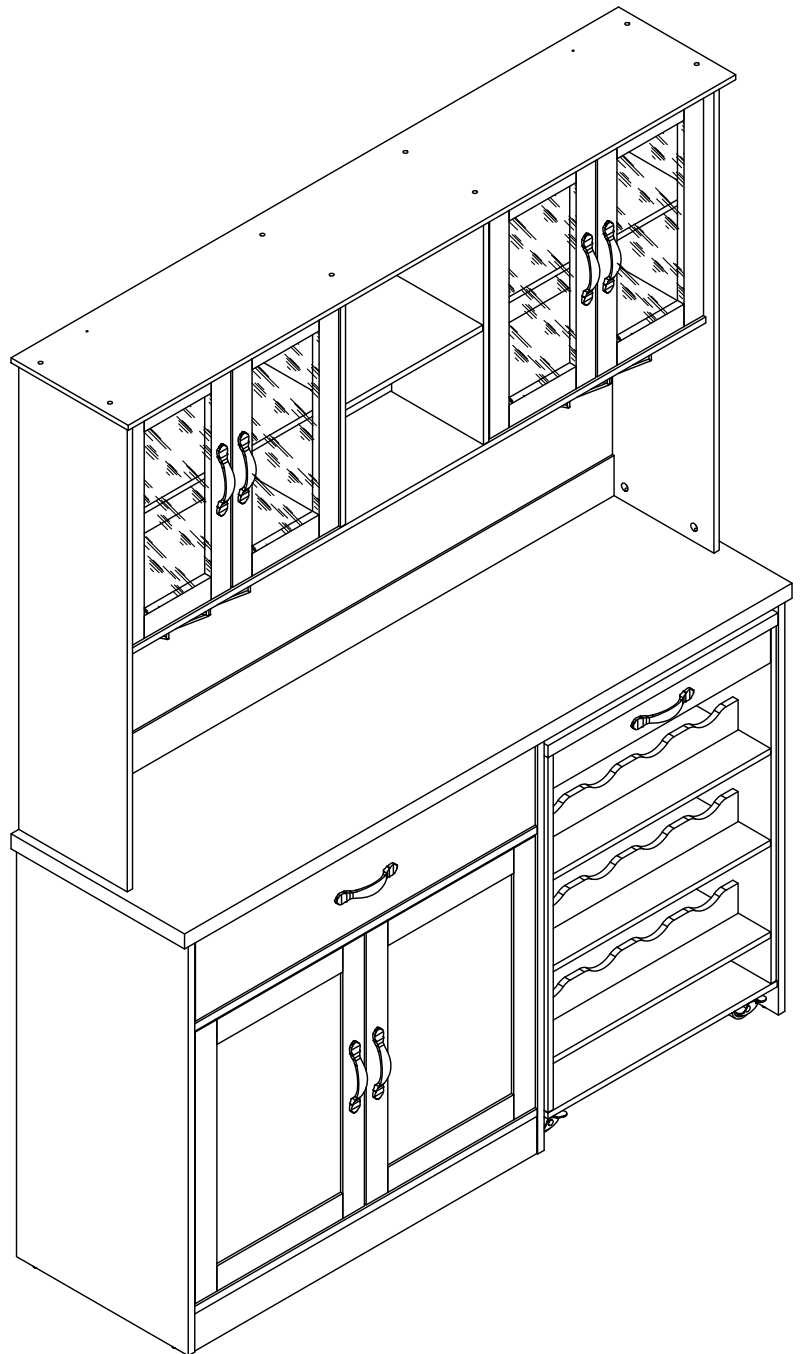

2 PERS

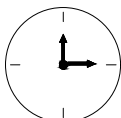

1 h 30 min

Tool Required Not Provided

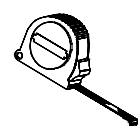
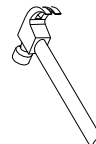
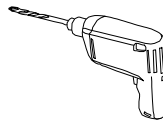
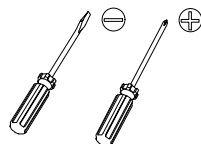

DE

Unser Produkt wird Ihnen in 2 Paketen geliefert. Die Lieferzeiten dieser 2 Pakete können abweichen, bitte haben Sie etwas Geduld und vielen Dank für Ihr Verständnis.

UK

Our product will be delivered to you in 2 packages. The delivery times of these 2 packages may differ, please be patient and thank you for your understanding.

FR

Notre produit vous sera livré en 2 colis. Les délais de livraison de ces 2 colis peuvent différer, soyez patient et merci pour votre compréhension.

IT

Il nostro prodotto verrà consegnato in 2 pacchi. I tempi di consegna di questi 2 pacchi possono variare; vi preghiamo di avere un po' di pazienza e vi ringraziamo per la vostra comprensione.

ES

Nuestro producto se entregará en 2 paquetes. Los tiempos de entrega de estos 2 paquetes pueden variar; por favor, tenga un poco de paciencia y gracias por su comprensión.

NL

Ons product wordt in 2 pakketten bij u geleverd. De levertijden van deze 2 pakketten kunnen verschillen, we vragen om uw geduld en bedanken u voor uw begrip.

SE

Vår produkt kommer att levereras till dig i 2 paket. Leveranstiderna för dessa 2 paket kan variera, vi ber om ditt tålamod och tackar för din förståelse.

PL

Nasz produkt zostanie dostarczony w 2 paczkach. Czas dostawy tych 2 paczek może się różnić, prosimy o cierpliwość i dziękujemy za zrozumienie.

WARNING

(DE)

1. Die maximale Tragfähigkeit des Produkts beträgt 60 kg, bitte nicht überladen.
2. Lassen Sie Kinder nicht auf Möbel klettern, da dies Umkippen und schwere Verletzungen verursachen kann.
3. Um die Sicherheit zu gewährleisten, installieren Sie bitte gemäß der Anleitung und ziehen Sie bei Bedarf Fachleute zurate.
4. Stellen Sie Möbel nicht in die Nähe von Feuerquellen oder heißen Gegenständen, um das Brandrisiko zu vermeiden.
5. Stellen Sie Möbel nicht in feuchten Umgebungen auf, um Materialschäden zu verhindern.
6. Überprüfen Sie regelmäßig alle Verbindungen und Befestigungen, um sicherzustellen, dass sie fest sind, um Unfälle zu vermeiden.
7. Reinigen Sie Möbel mit einem feuchten Tuch oder Alkohol, vermeiden Sie die Verwendung von reinigenden Mitteln mit ätzenden Chemikalien.

(UK)

1. The maximum weight capacity of the product is 60kg; do not overload.
2. Do not allow children to climb on furniture, as it may cause tipping and serious injury.
3. For safety, please install correctly according to the instructions, and seek professional assistance if necessary.
4. Do not place furniture near fire sources or hot items to avoid fire risk.
5. Do not place furniture in damp environments to prevent material damage.
6. Regularly check all connections and fasteners to ensure they are secure to prevent accidents.
7. Clean furniture with a damp cloth or alcohol; avoid using cleaners with corrosive chemicals.

(FR)

1. Ne laissez pas les enfants grimper sur les meubles, cela peut entraîner un basculement et des blessures graves.
2. Pour garantir la sécurité, veuillez installer correctement selon les instructions et demander de l'aide à des professionnels si nécessaire.
3. Ne placez pas les meubles. La capacité maximale de charge du produit est de 60 kg, ne pas surcharger.
4. Ne placez pas les meubles près de sources de chaleur ou d'objets chauds pour éviter les risques d'incendie.
5. Ne placez pas les meubles dans des environnements humides pour éviter d'endommager les matériaux.
6. Vérifiez régulièrement tous les raccords et fixations pour vous assurer qu'ils sont sécurisés afin d'éviter les accidents.
7. Nettoyez les meubles avec un chiffon humide ou de l'alcool, évitez d'utiliser des nettoyeurs contenant des produits chimiques corrosifs.

WARNING

(IT)

1. La capacità massima del prodotto è di 60 kg, non sovraccaricare.
2. Non permettere ai bambini di arrampicarsi sui mobili, poiché ciò potrebbe causare ribaltamenti e gravi infortuni.
3. Per garantire la sicurezza, installare correttamente secondo le istruzioni e chiedere assistenza a professionisti se necessario.
4. Non posizionare i mobili vicino a fonti di calore o oggetti caldi per evitare rischi di incendio.
5. Non posizionare i mobili in ambienti umidi per prevenire danni ai materiali.
6. Controllare regolarmente tutte le connessioni e le viti per assicurarsi che siano sicure e prevenire incidenti.
7. Pulire i mobili con un panno umido o alcol; evitare di utilizzare detergenti contenenti sostanze chimiche corrosive.

(ES)

1. La capacidad máxima del producto es de 60 kg, no sobrecargar.
2. No permita que los niños escalen los muebles, ya que puede provocar vuelcos y lesiones graves.
3. Para garantizar la seguridad, instale correctamente según las instrucciones y busque asistencia profesional si es necesario.
4. No coloque muebles cerca de fuentes de fuego u objetos calientes para evitar riesgos de incendio.
5. No coloque muebles en ambientes húmedos para evitar daños en los materiales.
6. Revise regularmente todas las conexiones y sujetadores para asegurarse de que estén firmes y prevenir accidentes.
7. Limpie los muebles con un paño húmedo o alcohol; evite usar limpiadores con productos químicos corrosivos.

(NL)

1. De maximale draagcapaciteit van het product is 60 kg; niet overbelasten.
2. Laat kinderen niet op meubels klimmen, dit kan omvallen en ernstige verwondingen veroorzaken.
3. Installeer correct volgens de instructies voor de veiligheid en vraag indien nodig om professionele hulp.
4. Plaats meubels niet in de buurt van vuurbronnen of hete voorwerpen om brandrisico te voorkomen.
5. Plaats meubels niet in vochtige omgevingen om materiaalschade te voorkomen.
6. Controleer regelmatig alle verbindingen en bevestigingen om ervoor te zorgen dat ze stevig zijn en ongelukken te voorkomen.
7. Maak meubels schoon met een vochtige doek of alcohol; vermijd het gebruik van schoonmaakmiddelen met bijtende chemicaliën.

WARNING

(SE)

1. Den maximala belastningen för produkten är 60 kg; överbelasta inte.
2. Låt inte barn klättra på möbler, eftersom det kan leda till att de tippar och orsakar allvarliga skador.
3. För att säkerställa säkerheten, installera korrekt enligt instruktionerna och be om professionell hjälp vid behov.
4. Placera inte möbler nära värmekällor eller heta föremål för att undvika brandrisk.
5. Placera inte möbler i fuktiga miljöer för att förhindra materialskador.
6. Kontrollera regelbundet alla anslutningar och fästen för att säkerställa att de är säkra för att förhindra olyckor.
7. Rengör möbler med en fuktig trasa eller alkohol; undvik att använda rengöringsmedel med frätande kemikalier.

(PL)

1. Maksymalne obciążenie produktu wynosi 60 kg: nie przeciążaj.
2. Nie pozwalaj dzieciom wspinac się na meble, ponieważ może to prowadzić do przewrócenia poważnych obrazem.
3. Aby zapewnić bezpieczeństwo, zainstaluj poprawnie zgodnie z instrukcjami w razie potrzeby skorzystaj z pomocy specjalistów.
4. Nie stawiaj mebli w pobliżu ognia lub gorących przedmiotów, aby uniknąć ryzyka pożaru.
5. Nie umieszczaj mebli w wilgotnym środowisku, aby zapobiec uszkodzeniu materiałów.
6. Regularnie sprawdzaj wszystkie połączenia mocowania, aby upewnić się, że są solidne, aby zapobiec wypadkom.
7. Czyszczenie mebli wilgotną szmatką lub alkoholem; unikaj używania środków czyszczących z trwałymi chemikaliami.

DE :Vor dem Einbau die Schrauben in die Löcher stecken und festziehen, aber nicht bis 100%, 70% bis 80% anziehen reicht aus. Schließlich, nachdem alle Schrauben installiert sind, ziehen Sie alle Schrauben auf 100%.

Wenn Sie auf diese Probleme stoßen, wie z. B. Fehlausrichtung der Löcher oder Unfähigkeit, bestimmte Teile zu installieren, überprüfen Sie bitte, ob die Schrauben korrekt verwendet werden und passen Sie die Dichtigkeit der Schrauben an.

UK :Before installation, insert the screws into the holes and tighten them, but do not tighten them to 100%, 70% to 80% is sufficient. Finally, after all screws are installed, tighten all screws to 100%. If you encounter these issues, such as if the holes cannot be aligned or some parts cannot be installed, please check if the screws are used correctly and adjust the tightness of the screws.

FR :Insérer la vis dans le trou avant la fin de l'assemblage, serrer la vis, mais ne pas serrer à 100%, 70% ~ 80% est correct. Enfin, une fois que toutes les vis sont bien serrées, toutes les vis sont serrées à 100%. Si vous rencontrez ces problèmes, par exemple si les trous ne sont pas alignés ou si certaines pièces ne peuvent pas être montées, vérifiez que les vis sont utilisées correctement et Ajustez leur serrage.

IT : Prima dell'installazione, inserire le viti nei fori e stringerle, ma non al 100%, è sufficiente stringerle al 70% - 80%. Infine, dopo aver installato tutte le viti, stringere tutte le viti al 100%. Se riscontri problemi come disallineamenti dei fori o difficoltà nell'installare alcuni componenti, verifica che le viti siano utilizzate correttamente e regola la tensione delle viti.

ES : Antes de la instalación, coloque los tornillos en los agujeros y apriételes, pero no al 100%; apretar al 70% - 80% es suficiente. Finalmente, después de haber instalado todos los tornillos, apriete todos los tornillos al 100%. Si se encuentra con problemas como desalineación de los agujeros o dificultad para instalar ciertas piezas, verifique que los tornillos se estén utilizando correctamente y ajuste la tensión de los tornillos.

NL : Voordat u begint met de installatie, plaatst u de schroeven in de gaten en draait u ze aan, maar draai ze niet volledig aan; 70% tot 80% is voldoende. Draai uiteindelijk, nadat alle schroeven zijn geplaatst, alle schroeven volledig aan. Als u problemen ondervindt, zoals niet uitgelijnde gaten of onderdelen die niet kunnen worden geïnstalleerd, controleer dan of de schroeven correct zijn gebruikt en pas de spanning van de schroeven aan.

SE : Innan installation, sätt i skruvarna i hålen och dra åt dem, men dra inte åt dem helt; 70% till 80% är tillräckligt. Slutligen, när alla skruvar är installerade, dra åt alla skruvar helt. Om du stöter på problem, som att hålen inte kan justeras eller vissa delar inte kan installeras, kontrollera om skruvarna används korrekt och justera skruvarnas åtdragning.

PL :Przed instalacją wstaw śruby w otwory i dokreć je. dle nie dokrecajich na 100%:70% do 80% wystarczy. Na koniec po zainstalowaniu wszystkich śrub dokreć wszystkie śruby do 100%. Jeśli napotkasz problemy, takie jak niedopasowane otwory lub części, które nie mogą być zainstalowane, sprawdź, czy śruby są używane prawidłowo i dostosuj ich dokreślenie.

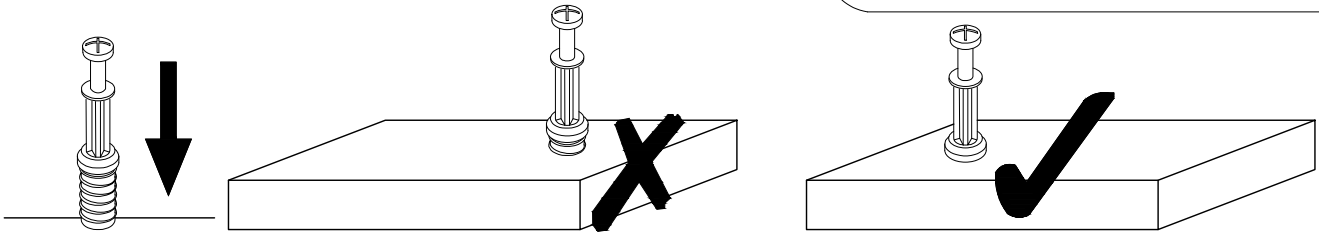

EN_QUICKFIT:Tighten quickfit until shoulder is flush with panel.Do not overtighten or undertighten.

FR_RACCORD RAPIDE:Faites serrer le raccord rapide jusqu'a ce que l'epaulement soit parfaitement encstre dans le panneau.Il ne faut ni trop serrer ni insuffisamment serrer.

ES_QUICKFIT:Apriete quickfit hasta que el hombre se descargue con el panel.NO lo sobreapriete ni lo apriete poco.

DE_QUICKFIT:Ziehen Sie den quickfit fest,bis die Schulter mit der Platte bundig ist. Bitte nicht zu fest oder zu schwach anziehen.

IT_MONTAGGIO RAPIDO:Stringere il montaggio rapido fino aquando la spalla e a filo con il pannello,non stringere troppo o troppo poco.

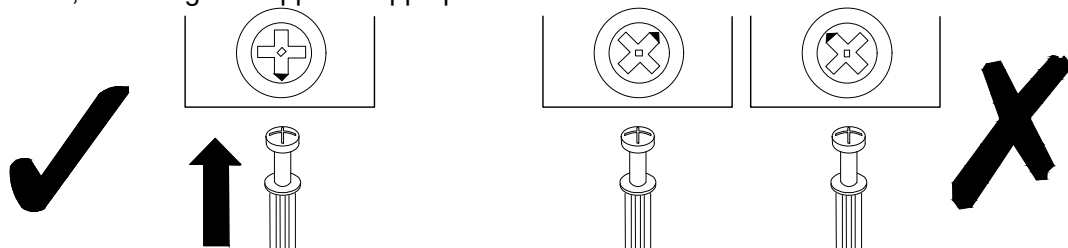

EN_CAM LOCK:When fitting cam lock,ensure starting position is correct before you insert connecting quickfit.

FR_SERRURE BATTEUSE:Avant d'insérer la serrure batteuse,veillez a la bonne orientation avant d'insérer le raccord rapide,

ES_CIERRE DE LA CAMARA:Cuando instale el cierre de la camara,asegurese de que la posicion de inicio es correcta antes de que inserte el quickfit conector,

De_CAM-LOCK:Achten Sie bei der Montage des Cam-locks auf die richtige Ausgangsposition,bevor Sie den Quickfit einsetzen.

IT_BLOCCAGGIO A CAMMA:Quando si monta il bloccaggio a camma,assicurarsi che la posizione iniziale sia corretta prima di inserire il montaggio rapido di collegamento.

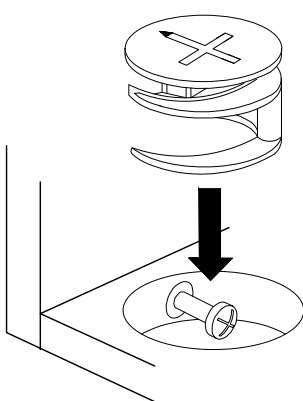

EN_Quickfit head should be in the centre of the cam lock when the two panels are joined.

Cam lock should be inserted before quickfit.

FR_Lorsque les deux panneaux sont assembles,la tete du raccord rapide doit reposer au centre de la serrure batteuse.

Il faut inserer la serrure batteuse avant le raccord rapide.

ES_EL cabezal del quickfit debe estar en el centro del cierre de la camara cuando se unan los dos paneles.

Se debe insertar el cierre de la camara antes que el quickfit.

DE_Der Quickfit-Kopf sollte sich in der Mitte des Cam-locks befinden,wenn die beiden Platten zusammengefugt sind.

Der Cam-lock sollte vor dem Quickfit eingesetzt werden.

IT_La testa del montaggio rapido deve trova rsi al centro del bloccaggio a camma quando i due pannelli sono uniti.

Il Bloccaggio a Camma deve essere inserito prima del montaggio rapido.

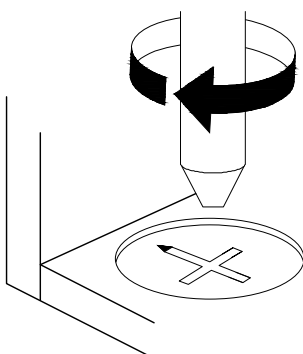

EN_Turn cam lock clockwise to tighten.

FR_Faites tourner la serrure batteuse dans le sens des aiguilles d'une montre pour la resserrer.

ES_Gire el cierre de la camara en sentido horario para apretarlo.

DE_Drehen Sie den Cam-Lock im Uhrzeigersinn,um ihn festzuziehen.

IT_Rutotare il bloccaggio a camma in senso oragio per stringere.

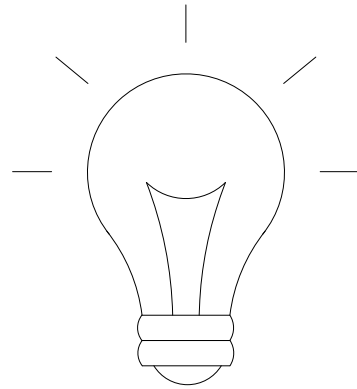
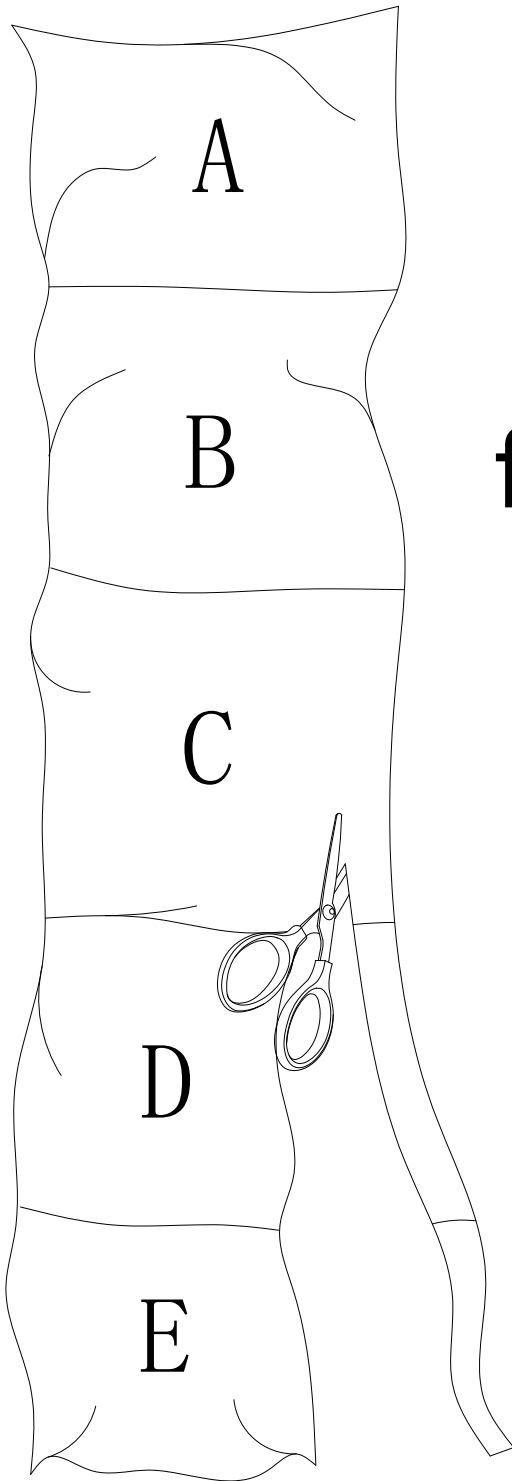

friendly reminder

To avoid errors and confusion during the installation of accessories, use the type and quantity of hardware accessories according to the installation procedure described in the instructions. First, unroll the accessories bag and lay out the hardware accessories, cut holes in the side, and take out the hardware accessories

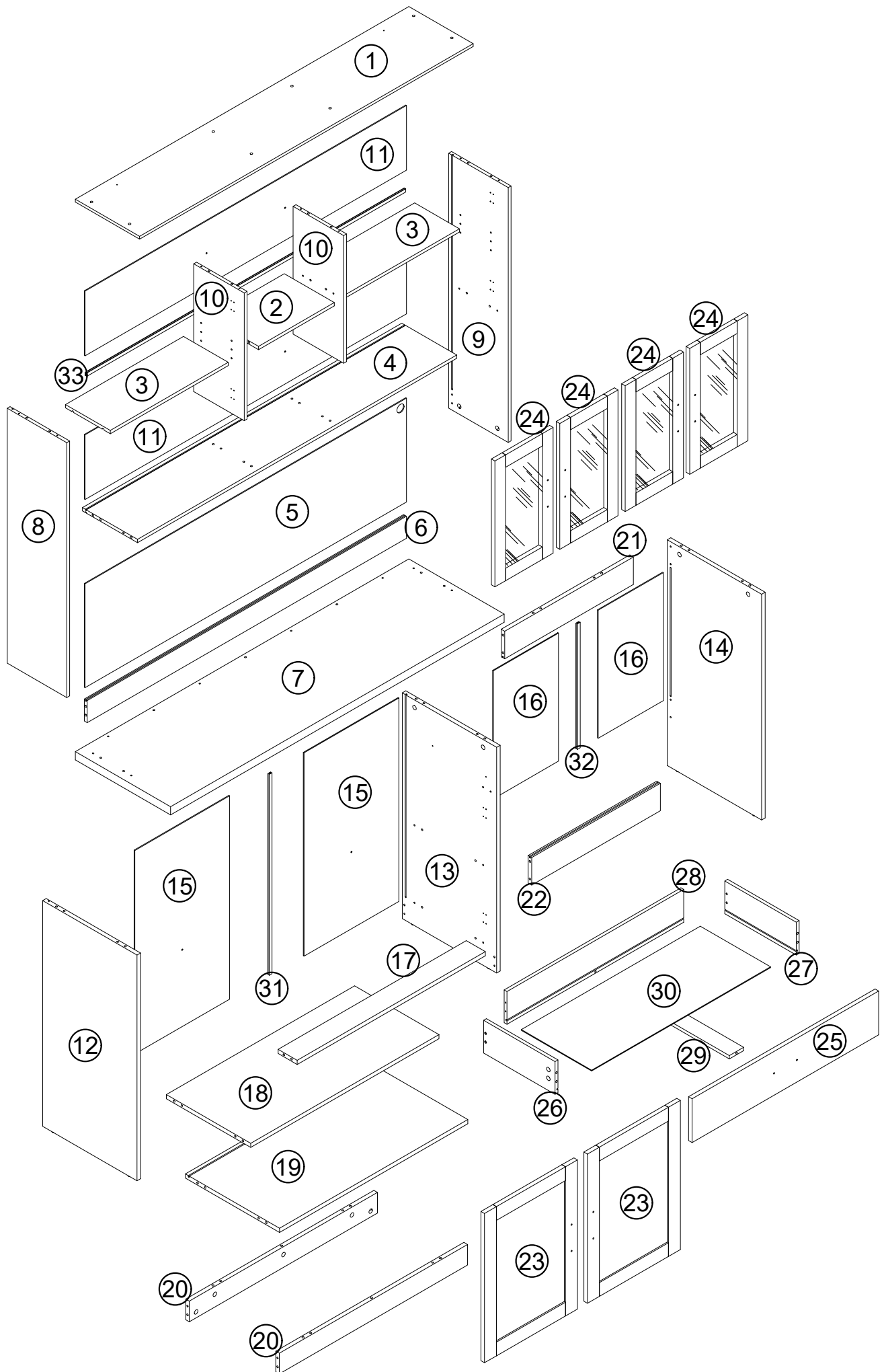

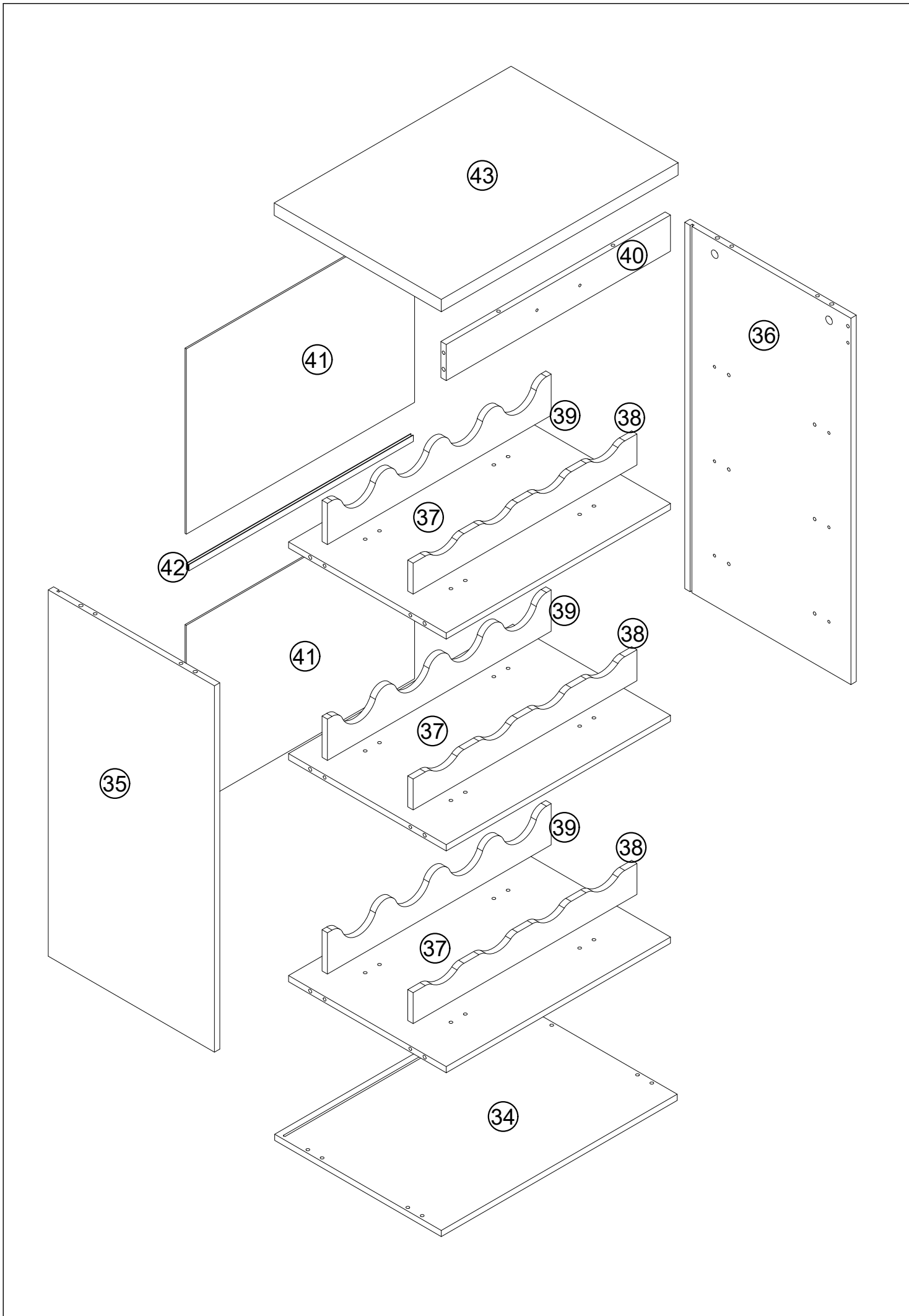

N620P403783

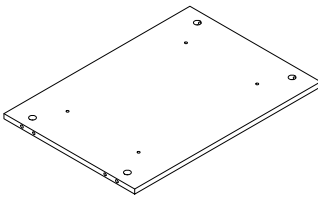
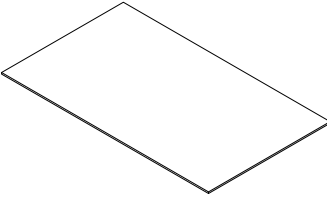
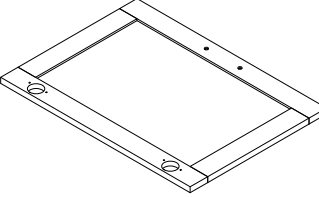
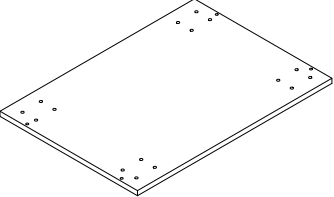
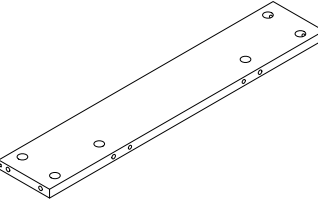
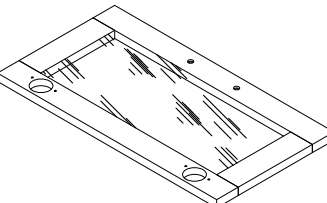
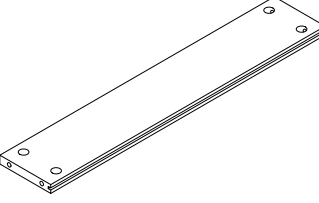
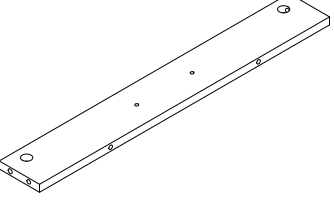
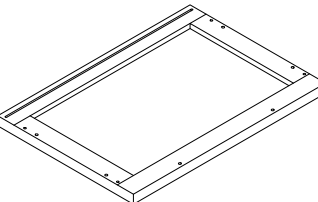
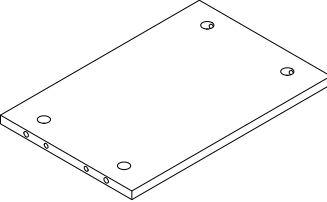
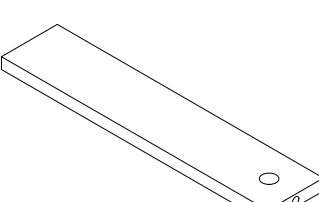
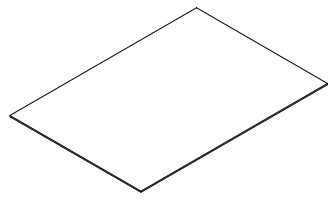
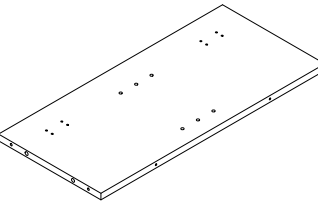
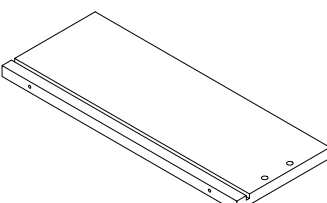
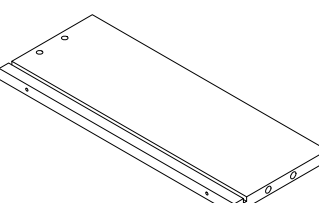
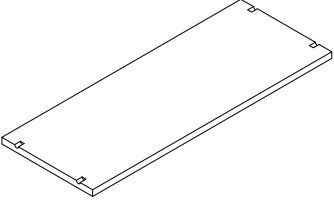
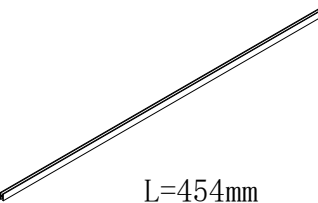
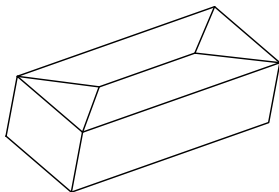
 <p>37 x3</p>	 <p>16 x2</p>	 <p>23 x2</p>	 <p>34 x1</p>
 <p>21 x1</p>	 <p>24 x4</p>	 <p>22 x1</p>	 <p>40 x1</p>
 <p>43 x1</p>	 <p>2 x1</p>	 <p>29 x1</p>	 <p>41 x2</p>
 <p>10 x2</p>	 <p>26 x1</p>	 <p>27 x1</p>	 <p>3 x2</p>
 <p>L=454mm</p> <p>32 x1</p>	 <p>Accessory box</p>		



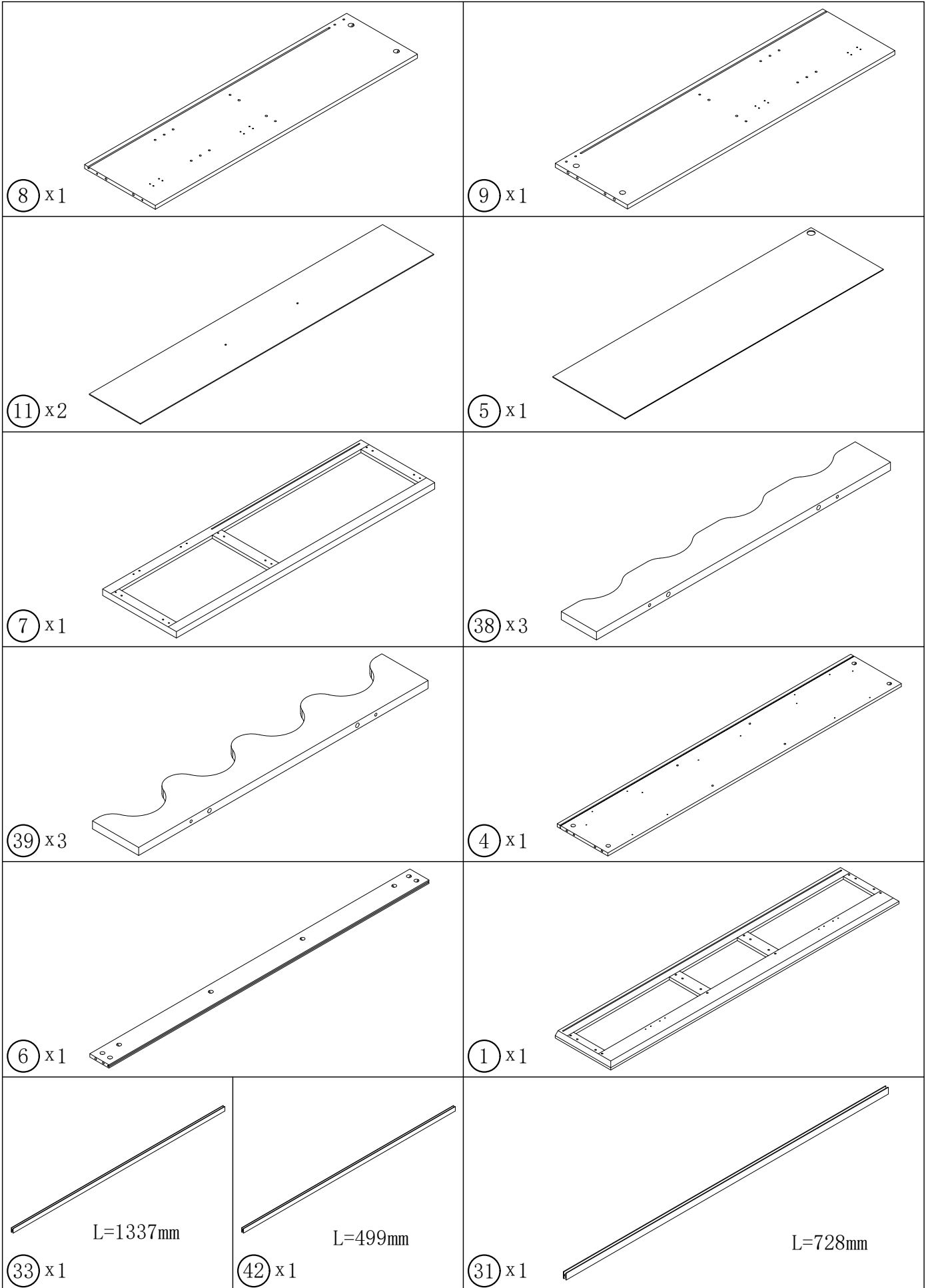



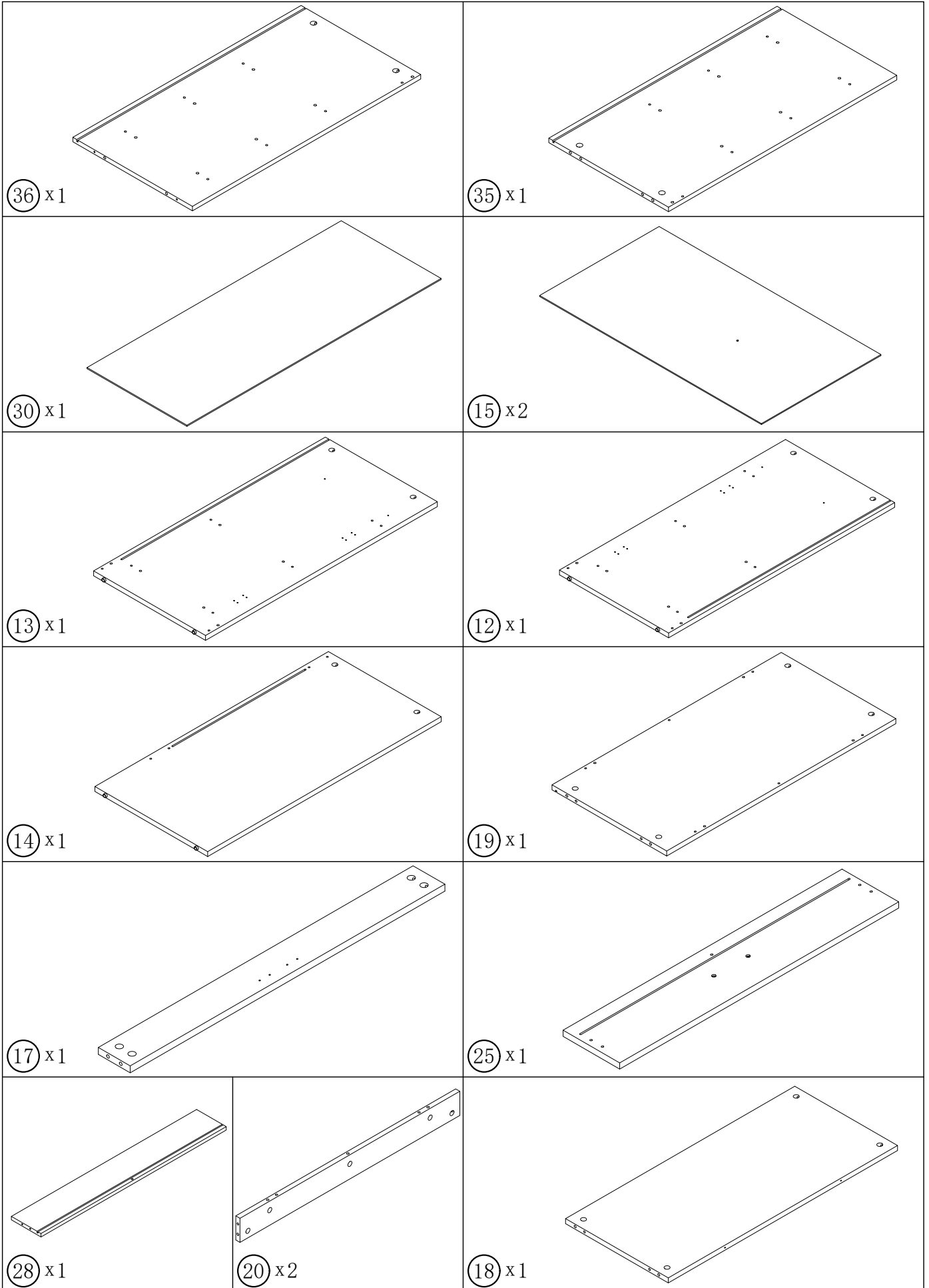

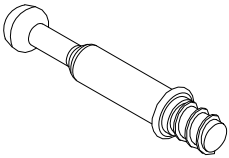
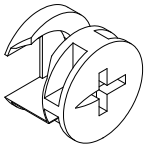
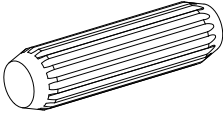

N620P403784

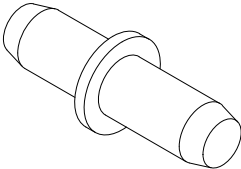
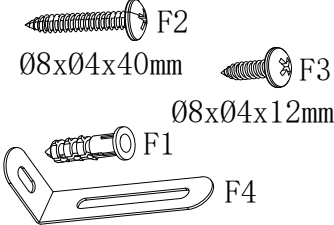
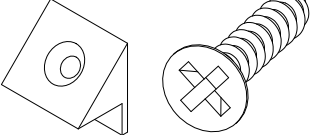
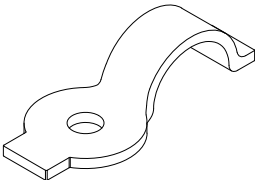
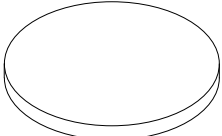
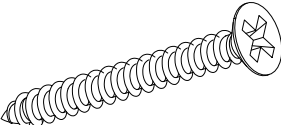
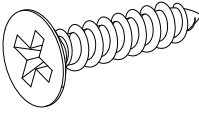
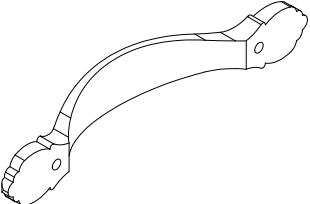
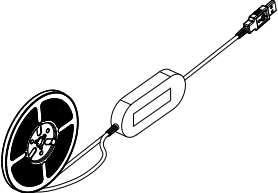
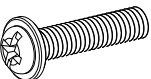
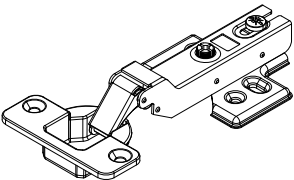
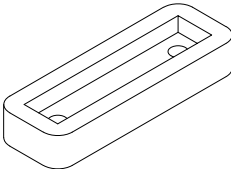
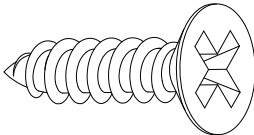
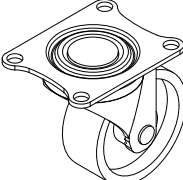
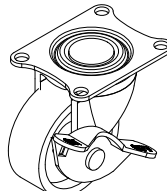
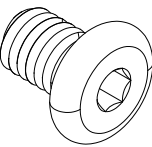
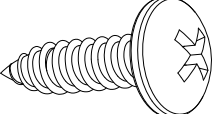
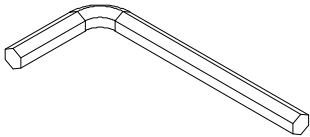
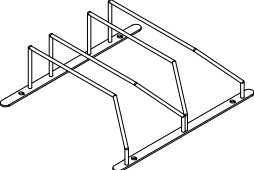
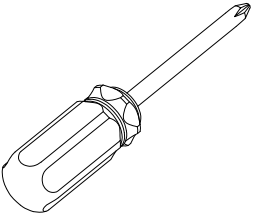

N620P403785

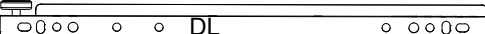
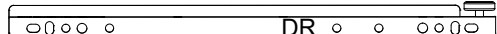

N620P403783

 <p>Ø6x35mm A x 81+5</p>	 <p>Ø15x10mm B x 81+5</p>	 <p>Ø6x30mm C x 87+5</p>	 <p>Ø5x38mm D x 33+3</p>
 <p>E x 8+1</p>	 <p>F2 Ø8xØ4x40mm F3 Ø8xØ4x12mm F1 F4 F x 2</p>	 <p>Ø6xØ3x16mm G x 44+4</p>	 <p>H x 6+3</p>
 <p>I x 52+5</p>	 <p>Ø8xØ4x35mm J x 6+1</p>	 <p>Ø6xØ3x12mm K x 26+3</p>	 <p>L x 8</p>
 <p>M x 1</p>	 <p>M4x16mm N x 16+2</p>	 <p>O x 12</p>	 <p>P x 6</p>
 <p>Ø7xØ3.5x14mm Q x 72+5</p>	 <p>R x 2</p>	 <p>S x 2</p>	 <p>M6x10mm T x 16+1</p>
 <p>Ø8xØ4x12mm U x 8+1</p>	 <p>4mm V x 1</p>	 <p>W x 2</p>	
 <p>CL x 1 300MM</p>	 <p>CL</p>	 <p>CR</p>	
 <p>DL x 1 300MM</p>	 <p>DL</p>	 <p>DR</p>	
 <p>DR x 1 300MM</p>	 <p>DL</p>	 <p>DR</p>	

Step 1

K ✓ Ø6xØ3x12	G ✗ Ø6xØ3x16	Q ✗ Ø7xØ3.5x14	J ✗ Ø8xØ4x35
---------------------------	---------------------------	-----------------------------	---------------------------

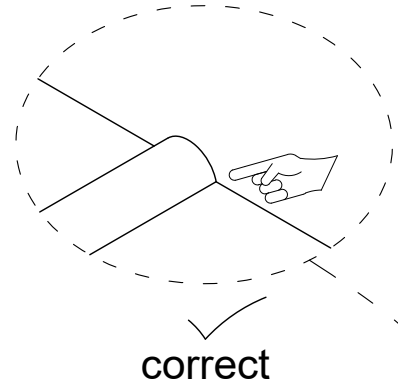
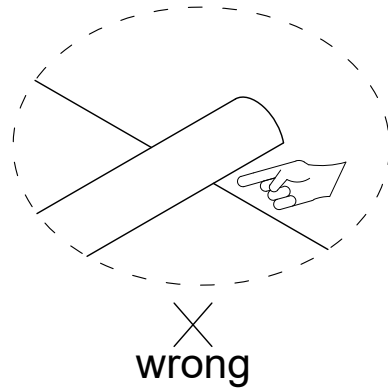
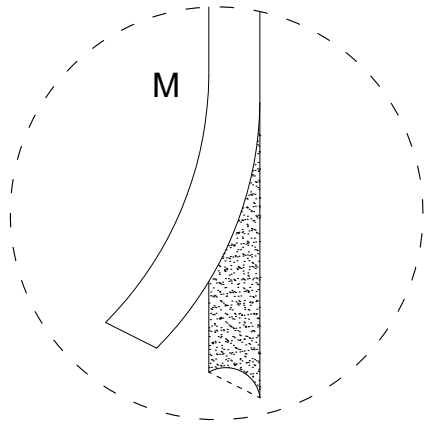

DE: Bitte beachten Sie, dass der Lichtstreifen nicht über den Rand der Platte hinausragen sollte; er kann bündig mit der Kante abschließen oder leicht zurückgesetzt sein.

UK: Please note that the light strip should not extend beyond the edge of the board; it may be flush with the edge or slightly recessed.

FR: Veuillez noter que la bande lumineuse ne doit pas dépasser du bord de la planche ; elle peut être alignée avec le bord ou légèrement encastrée.

IT: Si prega di notare che la striscia luminosa non deve sporgere oltre il bordo della scheda; può essere a filo con il bordo o leggermente incassata.

ES: Tenga en cuenta que la tira de luces no debe sobresalir del borde de la placa; puede quedar al ras del borde o ligeramente empotrada.

NL: Houd er rekening mee dat de lichtstrip niet voorbij de rand van het bord mag uitsteken; deze mag gelijk liggen met de rand of iets verzonken zijn.

SE: Observera att ljuslisten inte får sticka ut utanför kanten på skivan; den kan ligga i jämnhöjd med kanten eller vara något infälld.

PL: Należy pamiętać, że listwa świetlna nie powinna wystawać poza krawędź płyty; może być zlicowana z krawędzią lub lekko cofnięta.

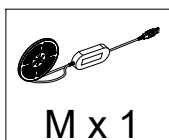
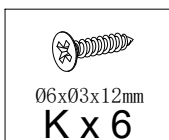
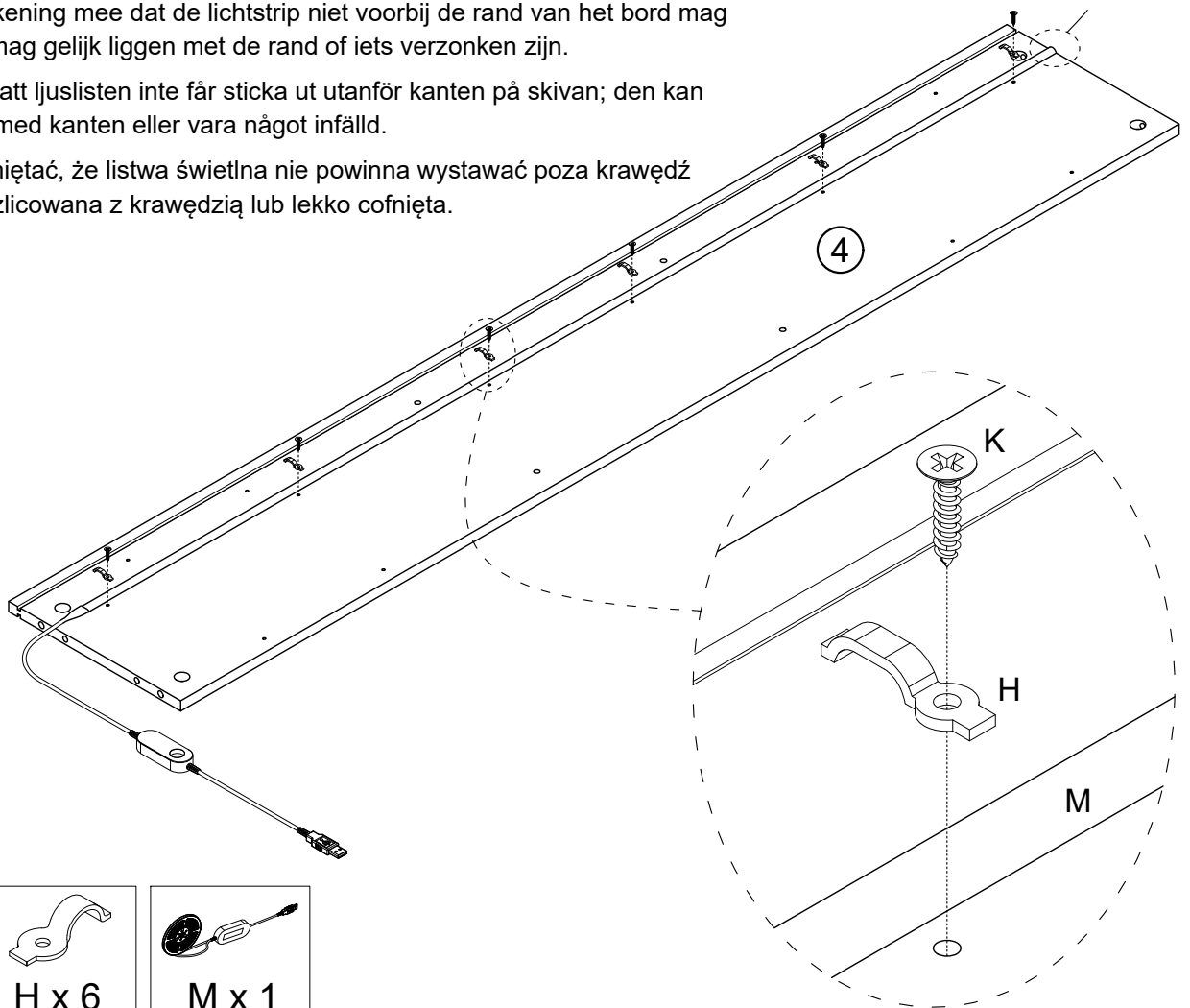

Step 2

DE: Achten Sie bei der Installation auf die Ausrichtung der Komponenten 4 und des Weinglashalters W.

UK: When installing, pay attention to the directions of components 4 and the wine glass holder W.

FR: Lors de l'installation, faites attention à l'orientation des composants 4 et du support pour verres à vin W.

IT: Durante l'installazione, prestare attenzione alle direzioni dei componenti 4 e del portabicchieri W.

ES: Durante la instalación, preste atención a las instrucciones de los componentes 4 y el soporte para copas de vino W.

NL: Let bij de installatie op de richtingen van onderdelen 4 en de wijnglashouder W.

SE: Vid installation, var uppmärksam på riktingarna för komponenterna 4 och vinglashållaren W.

PL: Podczas montażu należy zwrócić uwagę na kierunki elementów 4 i uchwyty na kieliszki do wina W.

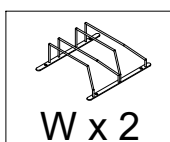
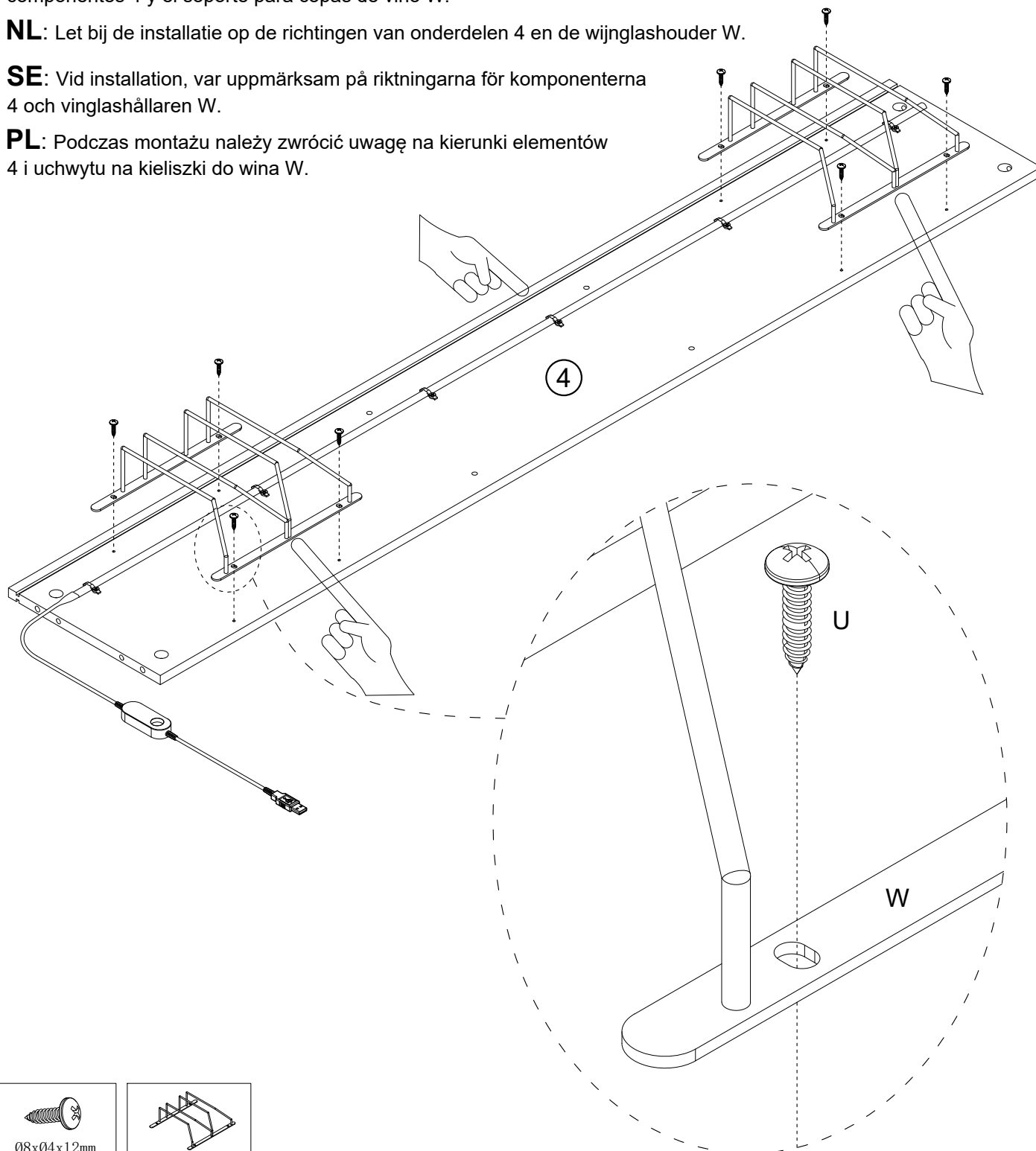

Step 3

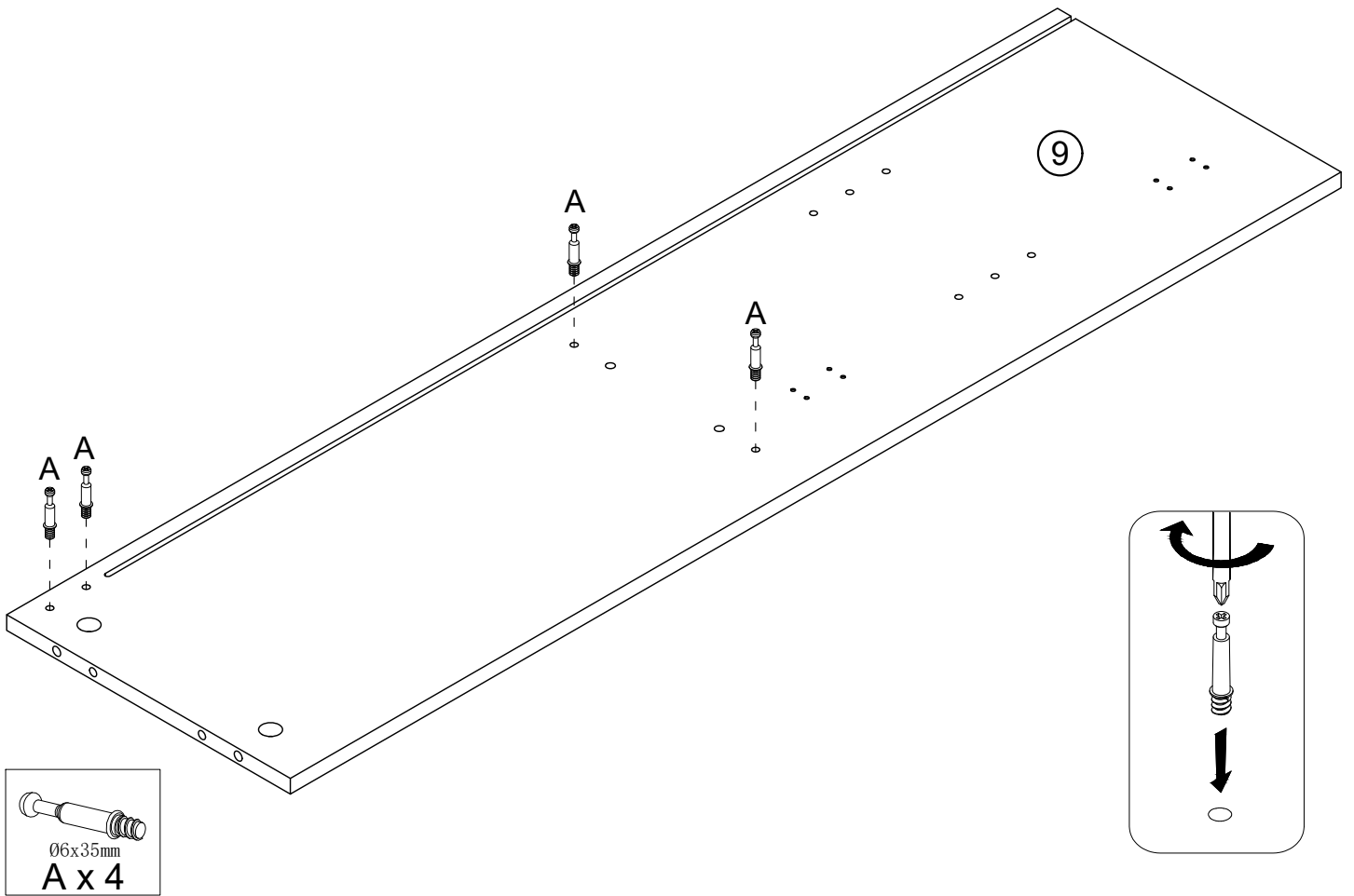

Step 4

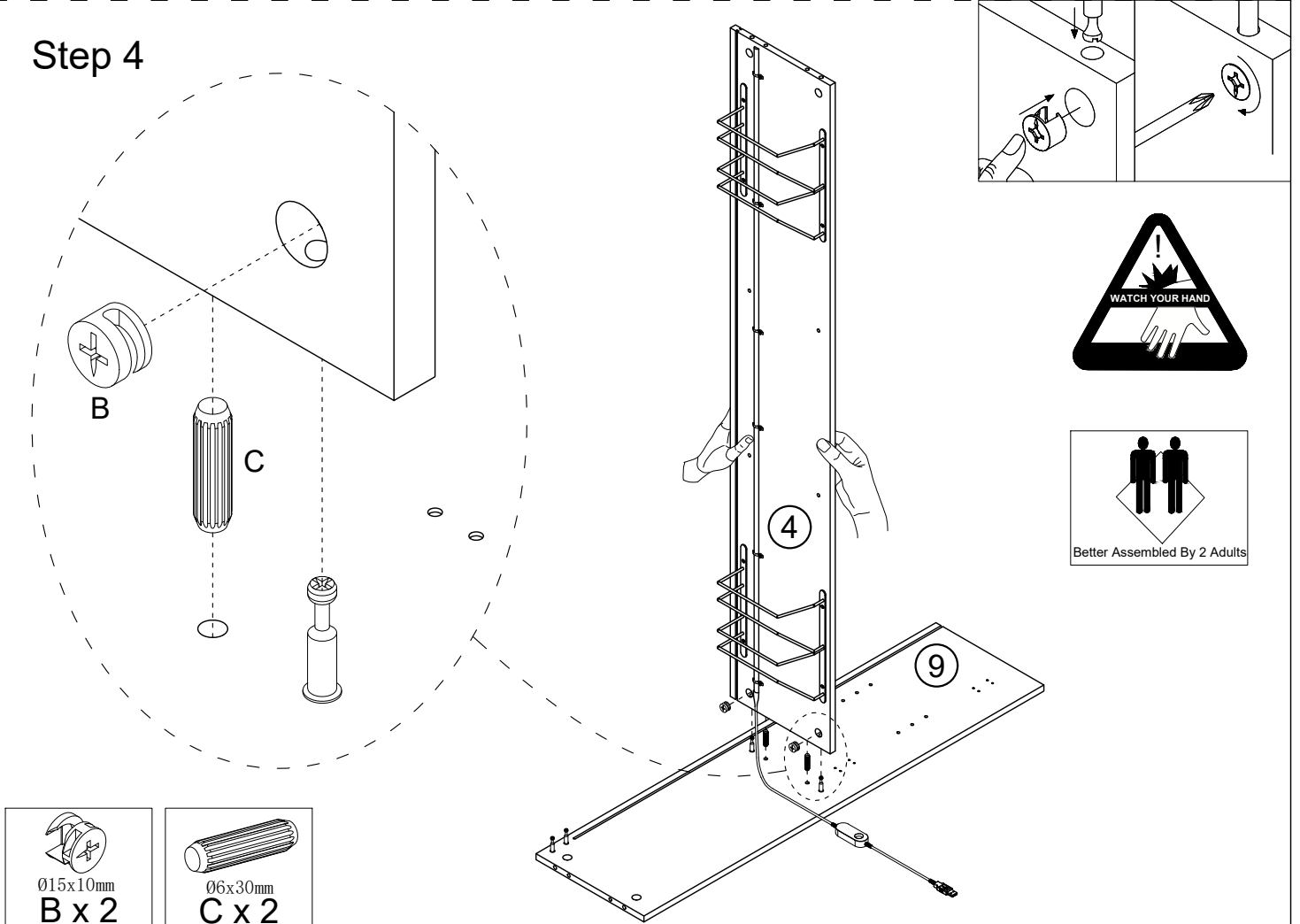

Step 5

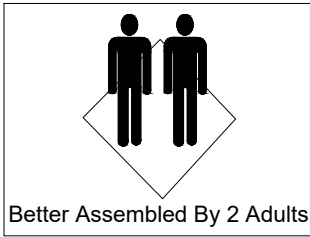
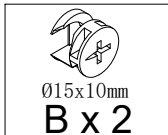
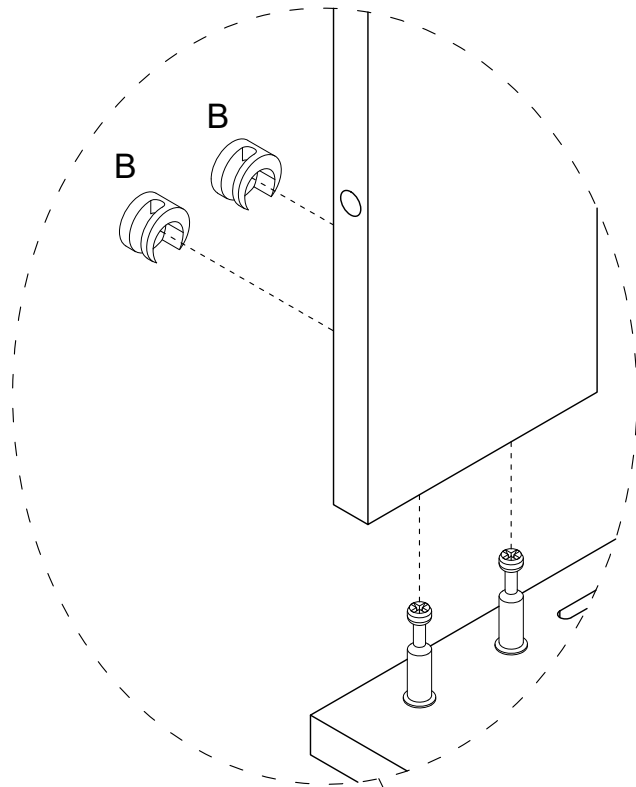
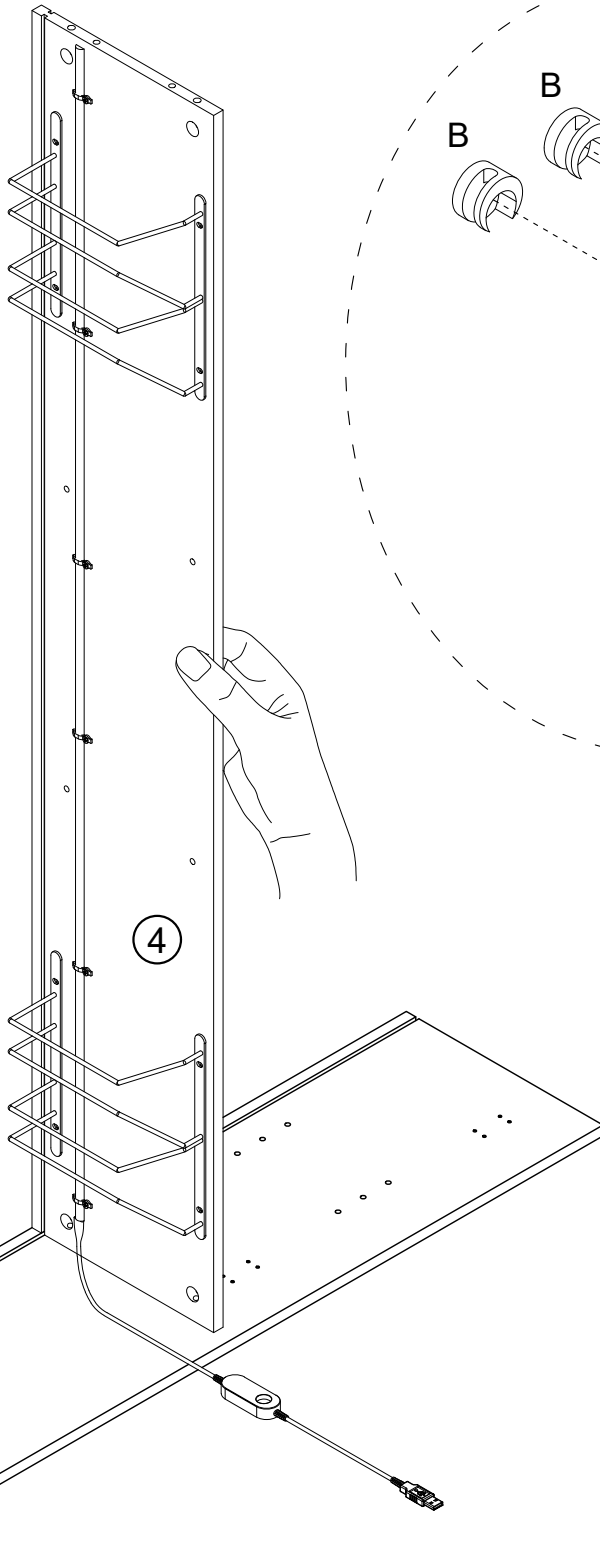
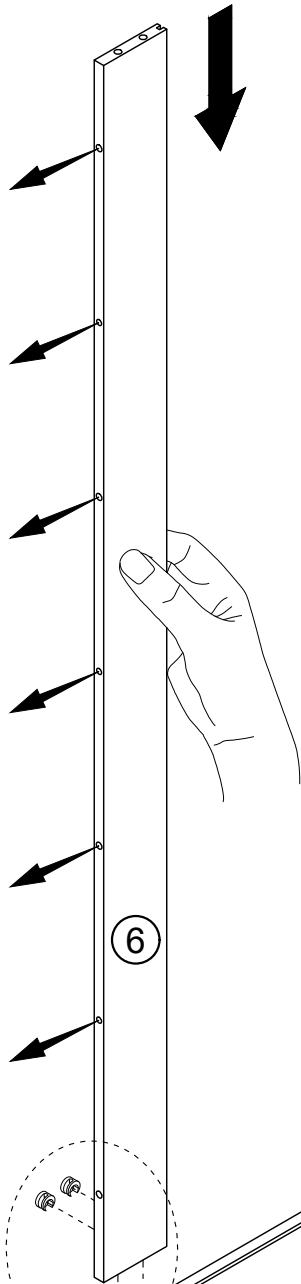

Step 6

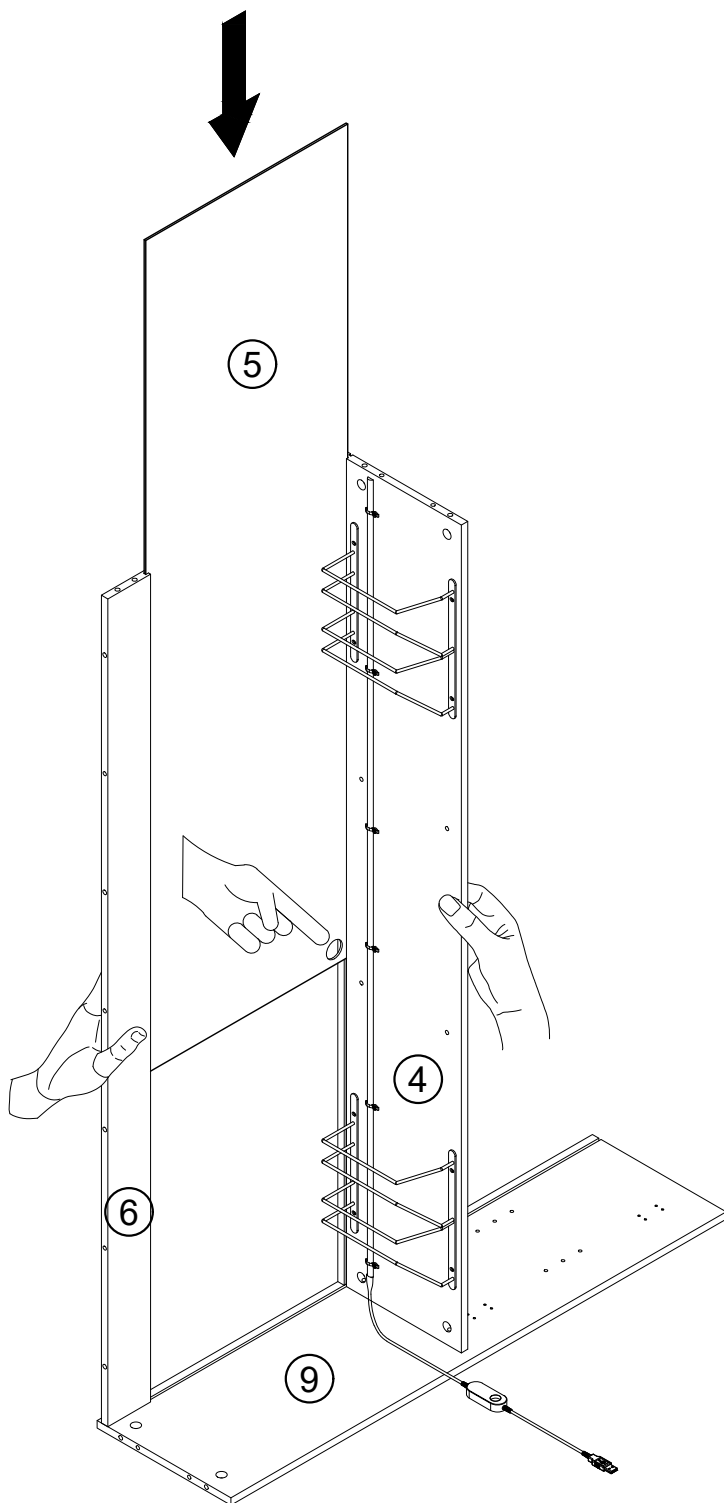

DE: Die dünne Platte muss vollständig in die Nut eingeführt werden. Wenn das Einführen nicht reibungslos verläuft, können Sie versuchen, von vorne oder von hinten Druck auszuüben, um Anpassungen vorzunehmen, bis die dünne Platte vollständig in die Nut eingeführt ist.

UK: The thin plate needs to be fully inserted into the groove. If the insertion is not smooth, you can try pressing from the front or the back to make adjustments until the thin plate is fully inserted into the groove.

FR: La plaque mince doit être entièrement insérée dans la rainure. Si l'insertion ne se fait pas facilement, vous pouvez essayer d'appuyer à l'avant ou à l'arrière pour ajuster la plaque jusqu'à ce qu'elle soit entièrement insérée dans la rainure.

IT: La piastra sottile deve essere inserita completamente nella scanalatura. Se l'inserimento non avviene in modo fluido, è possibile provare a premere dalla parte anteriore o posteriore per effettuare le regolazioni necessarie fino a quando la piastra sottile non è inserita completamente nella scanalatura.

ES: La placa delgada debe insertarse completamente en la ranura. Si la inserción no es fluida, puede intentar presionar desde la parte delantera o trasera para realizar ajustes hasta que la placa delgada se inserte completamente en la ranura.

NL: De dunne plaat moet volledig in de groef worden gestoken. Als het insteken niet soepel verloopt, kunt u proberen vanaf de voorkant of de achterkant druk uit te oefenen om aanpassingen te maken totdat de dunne plaat volledig in de groef is gestoken.

SE: Den tunna plattan måste sättas in helt i spåret. Om den inte går in smidigt kan du försöka trycka från framsidan eller baksidan för att justera tills den tunna plattan är helt insatt i spåret.

PL: Cienką płytkę należy całkowicie wsunąć w rowek. Jeśli wsuwanie nie przebiega płynnie, można spróbować docisnąć ją od przodu lub od tyłu, dopasowując ją tak, aby całkowicie wsunęła się w rowek.

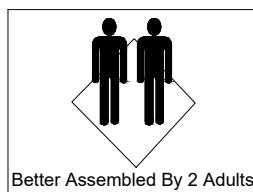

Step 7

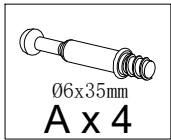
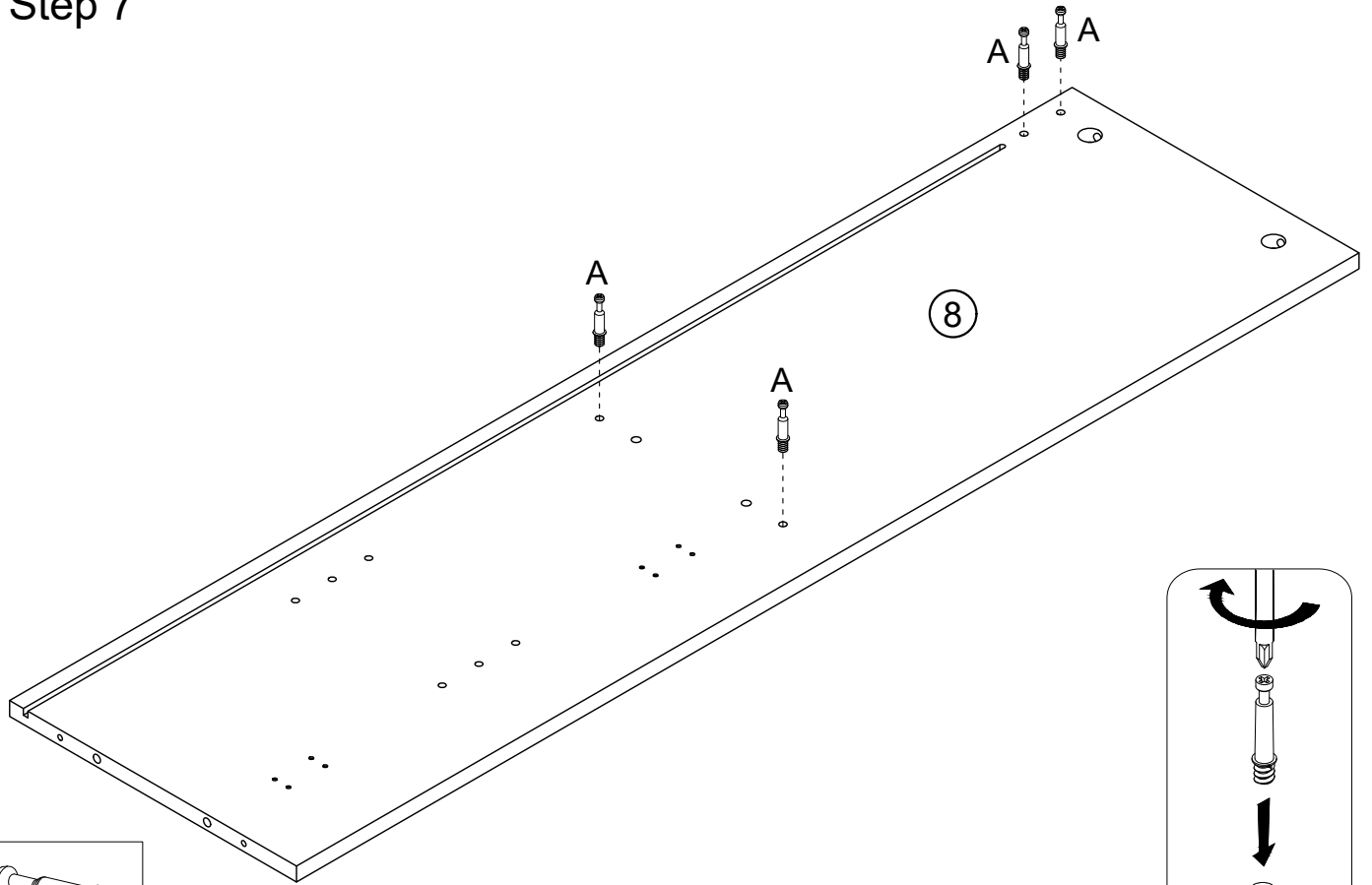

Step 8

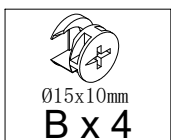
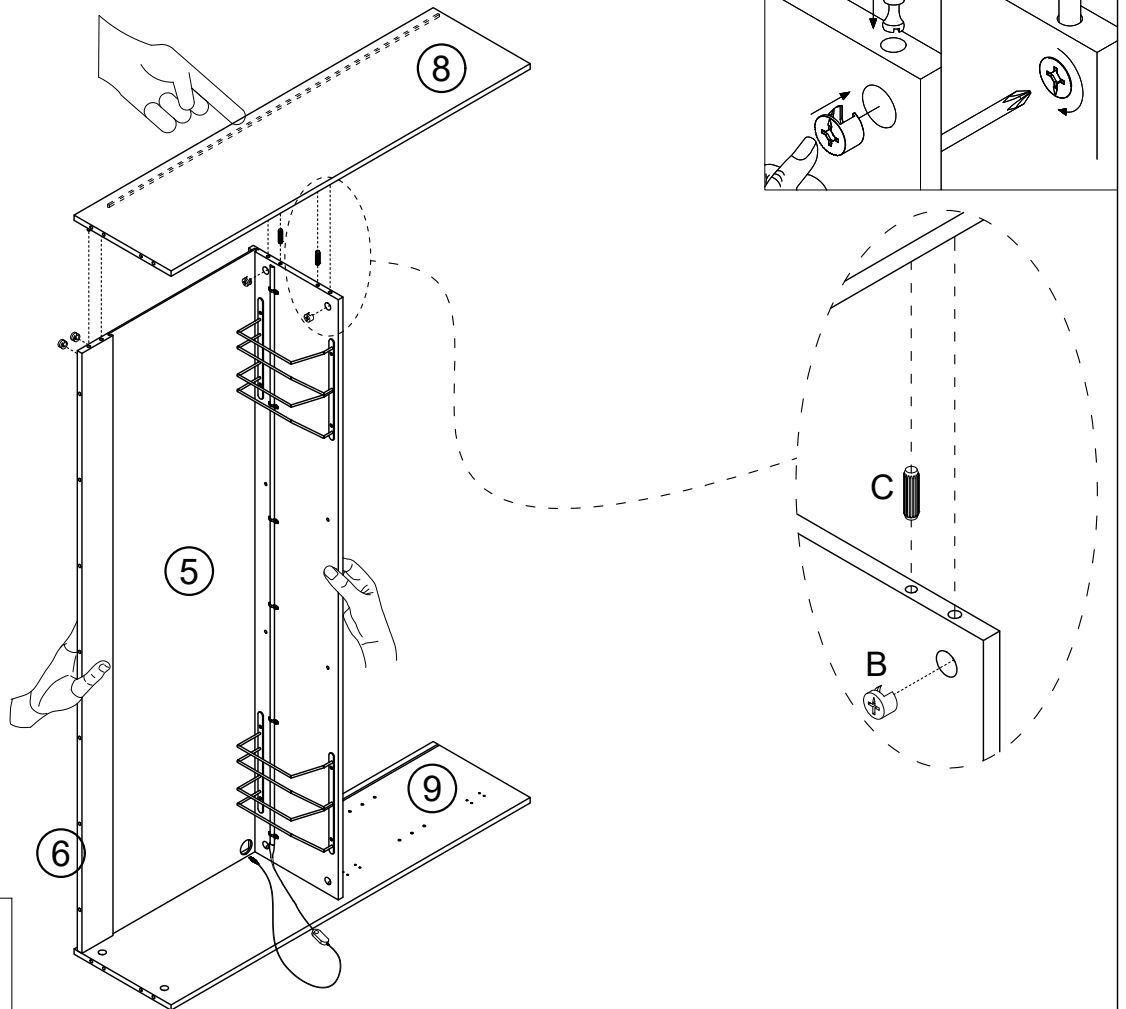
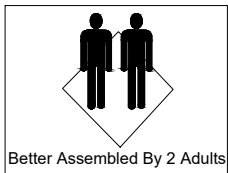

Step 9

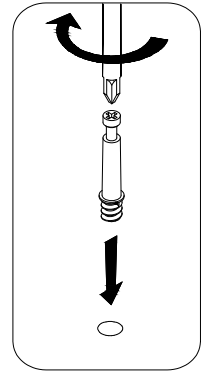
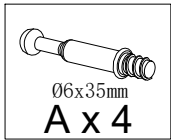
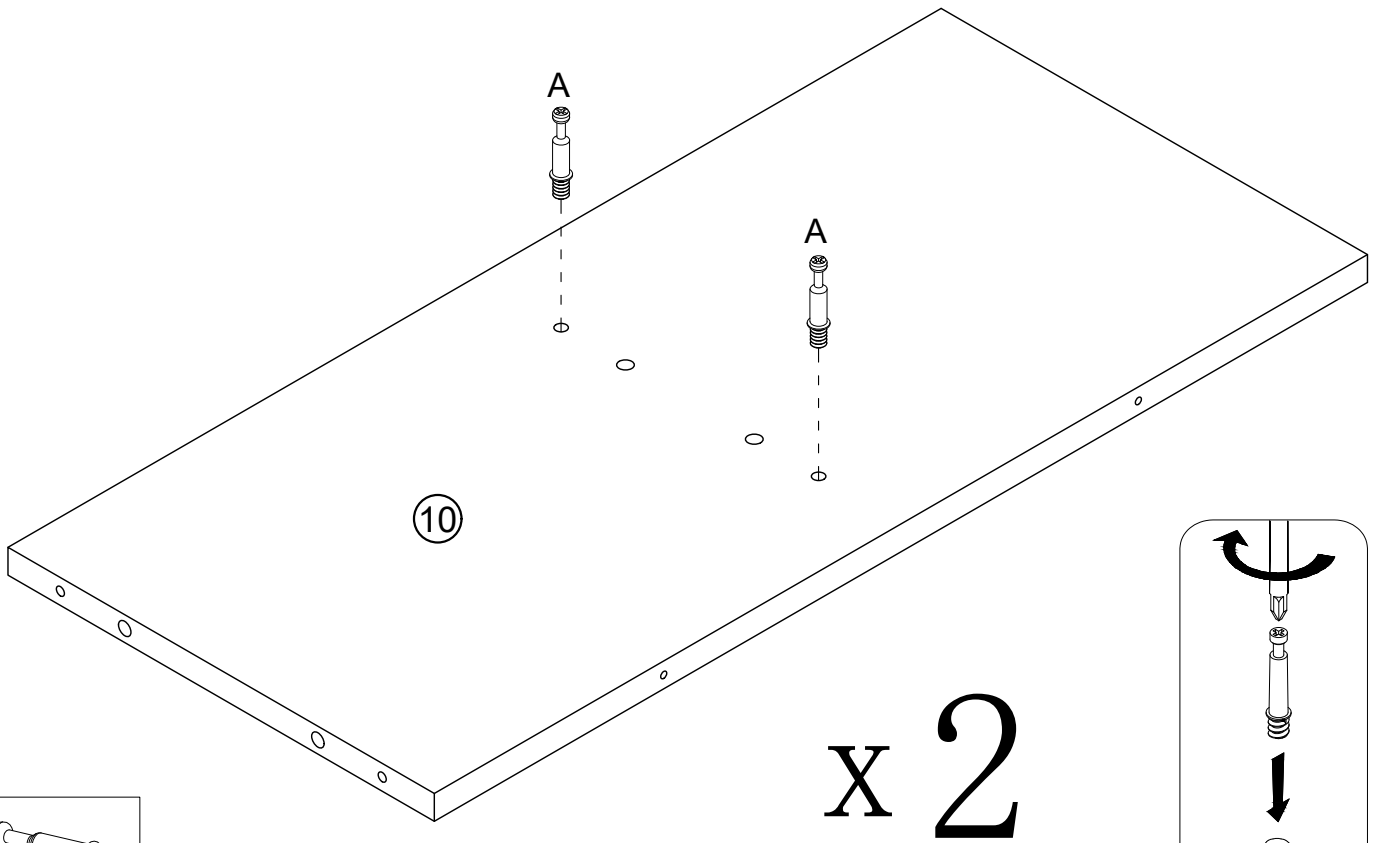

Step 10

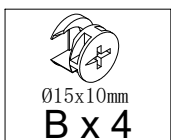
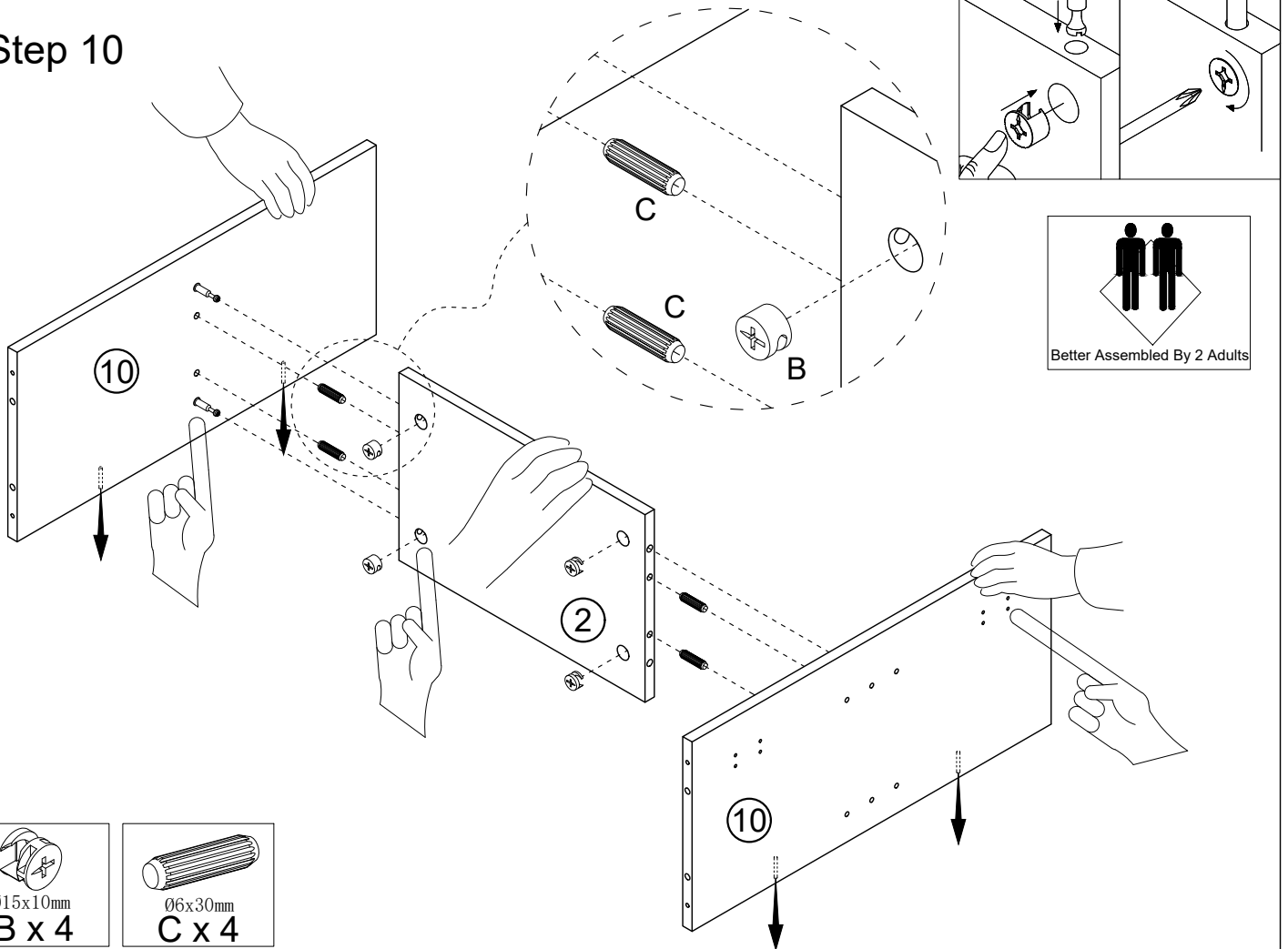

Step 11

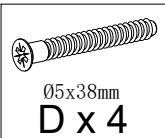
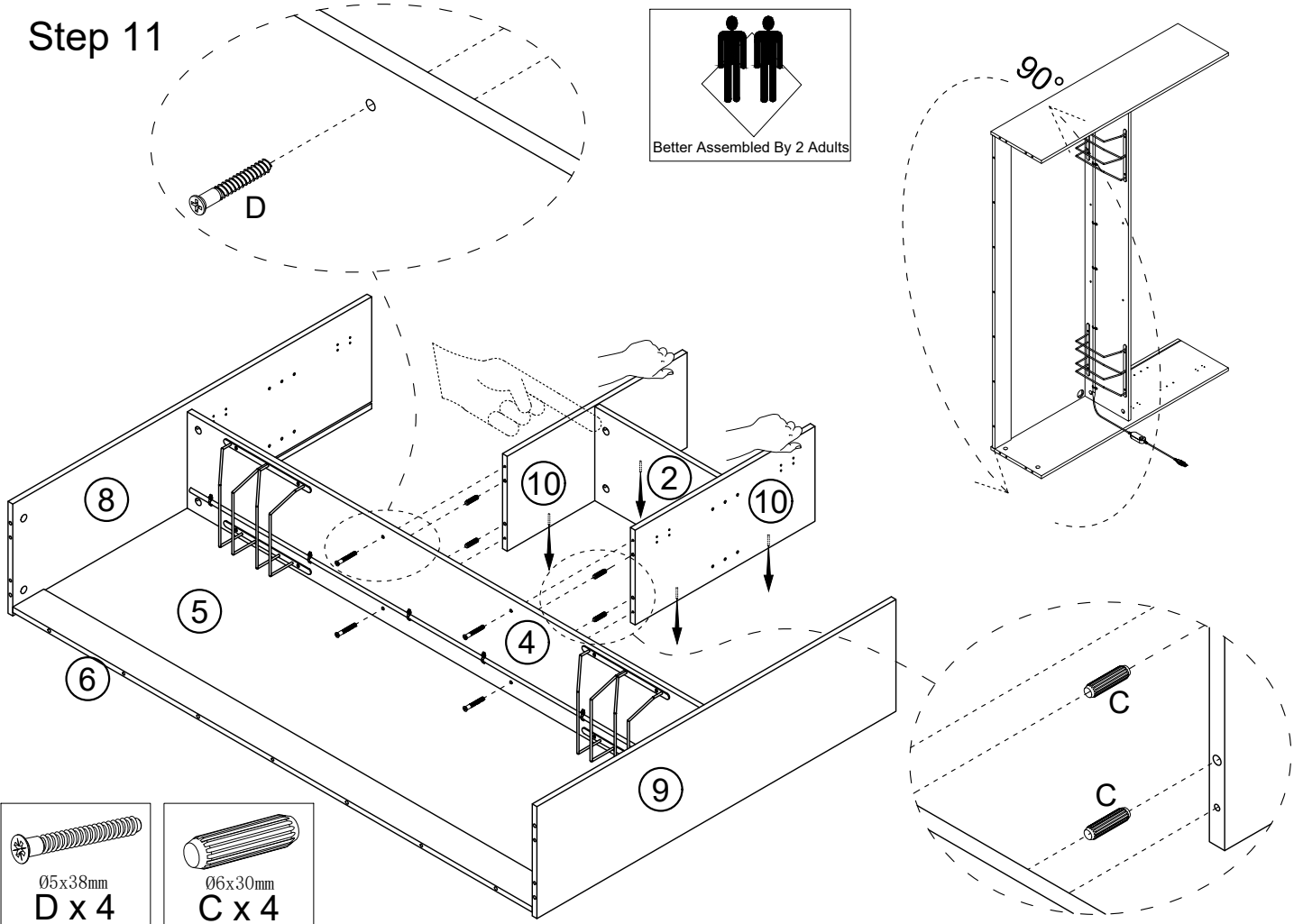
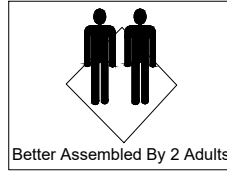

Step 12

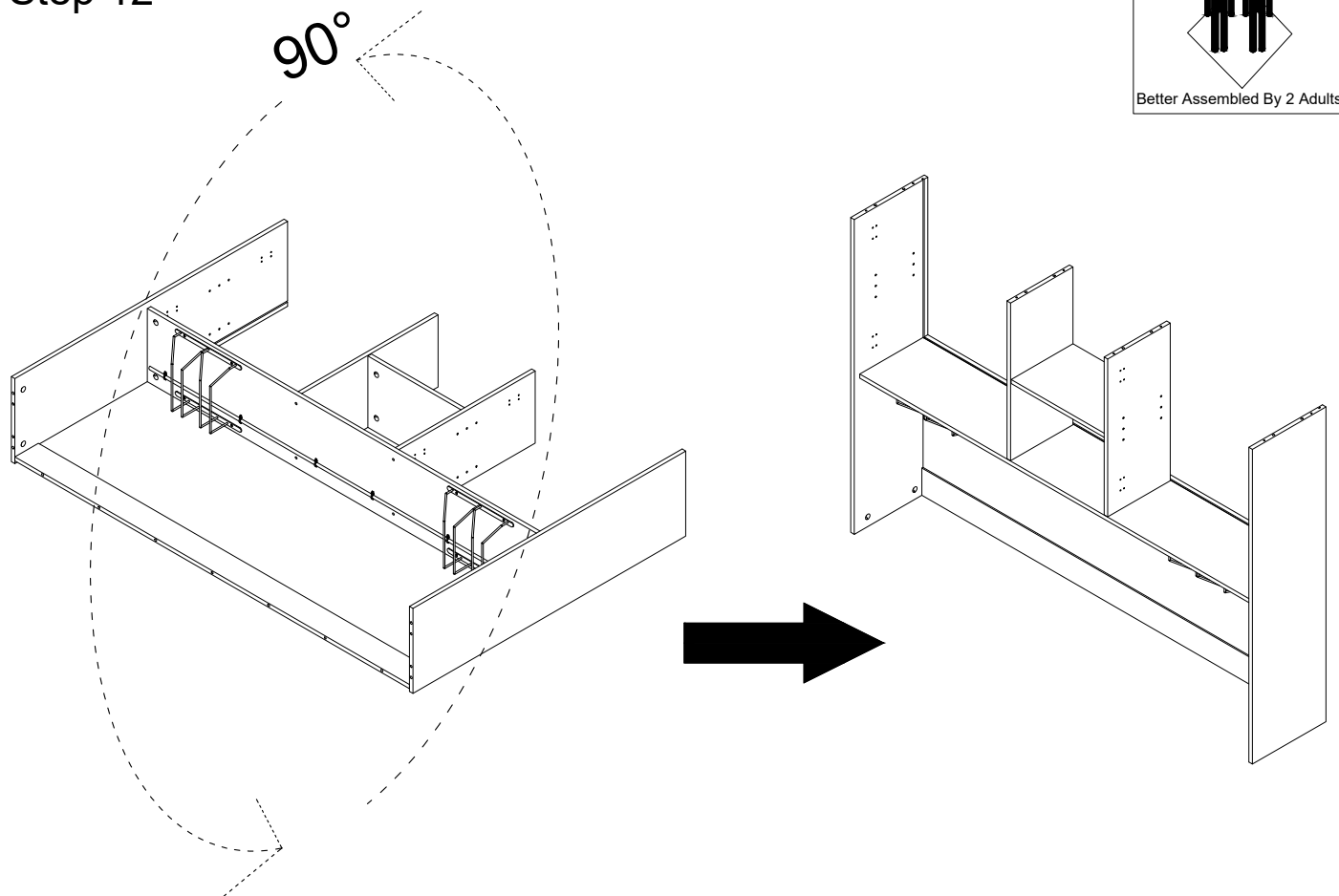
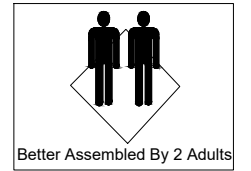

Step 13

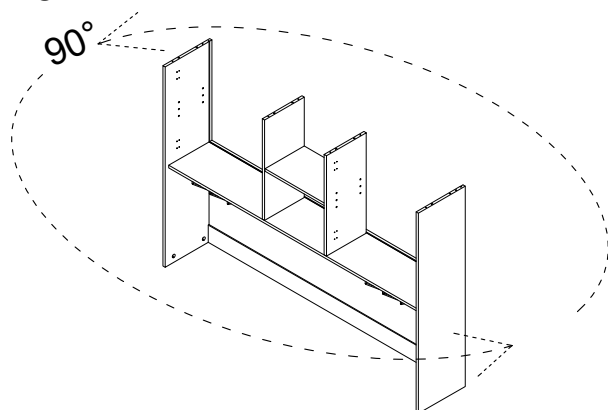

DE: Die dünne Platte muss vollständig in die Nut eingeführt werden. Wenn das Einführen nicht reibungslos verläuft, können Sie versuchen, von vorne oder von hinten Druck auszuüben, um Anpassungen vorzunehmen, bis die dünne Platte vollständig in die Nut eingeführt ist.

UK: The thin plate needs to be fully inserted into the groove. If the insertion is not smooth, you can try pressing from the front or the back to make adjustments until the thin plate is fully inserted into the groove.

FR: La plaque mince doit être entièrement insérée dans la rainure. Si l'insertion ne se fait pas facilement, vous pouvez essayer d'appuyer à l'avant ou à l'arrière pour ajuster la plaque jusqu'à ce qu'elle soit entièrement insérée dans la rainure.

IT: La piastra sottile deve essere inserita completamente nella scanalatura. Se l'inserimento non avviene in modo fluido, è possibile provare a premere dalla parte anteriore o posteriore per effettuare le regolazioni necessarie fino a quando la piastra sottile non è inserita completamente nella scanalatura.

ES: La placa delgada debe insertarse completamente en la ranura. Si la inserción no es fluida, puede intentar presionar desde la parte delantera o trasera para realizar ajustes hasta que la placa delgada se inserte completamente en la ranura.



NL: De dunne plaat moet volledig in de groef worden gestoken. Als het insteken niet soepel verloopt, kunt u proberen vanaf de voorkant of de achterkant druk uit te oefenen om aanpassingen te maken totdat de dunne plaat volledig in de groef is gestoken.

SE: Den tunna plattan måste sättas in helt i spåret. Om den inte går in smidigt kan du försöka trycka från framsidan eller baksidan för att justera tills den tunna plattan är helt insatt i spåret.

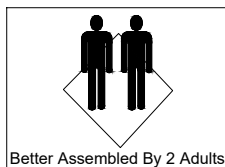
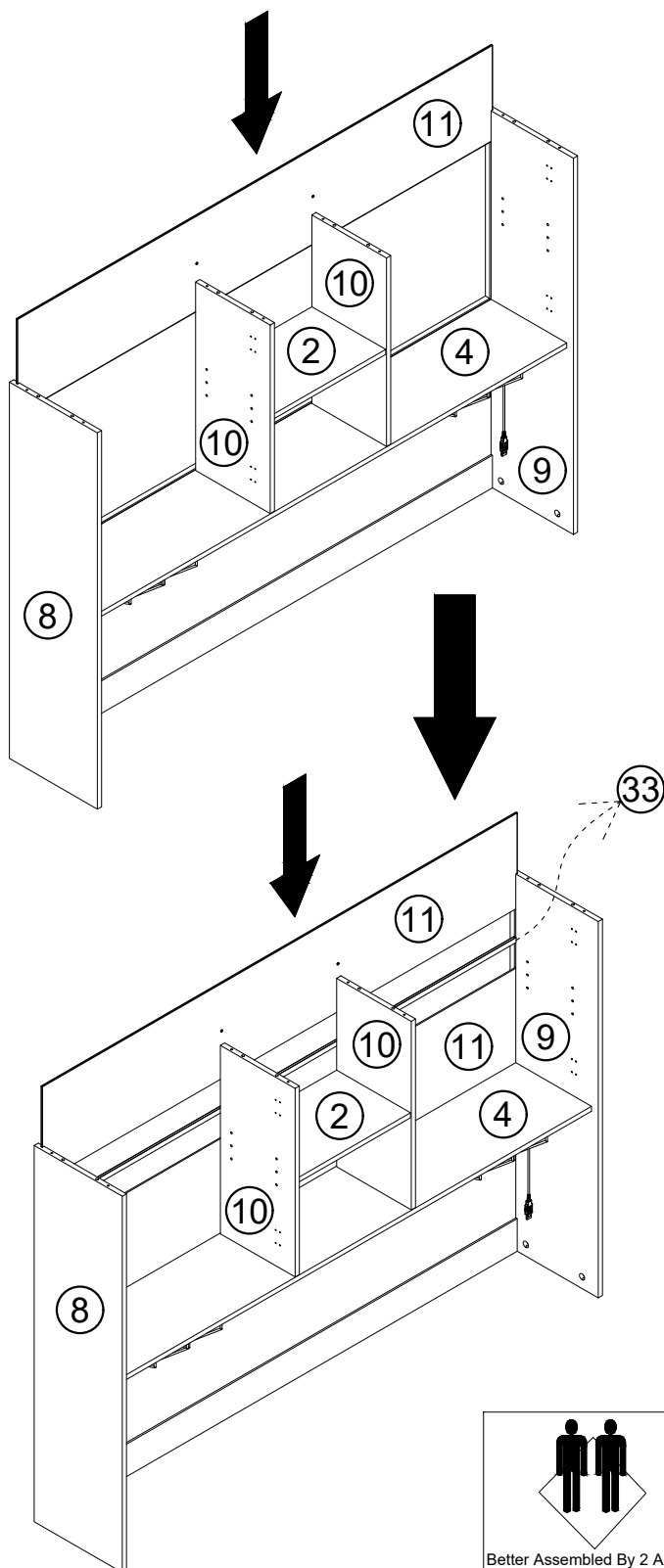
PL: Cienką płytkę należy całkowicie wsunąć w rowek. Jeśli wsuwanie nie przebiega płynnie, można spróbować docisnąć ją od przodu lub od tyłu, dopasowując ją tak, aby całkowicie wsunęła się w rowek.

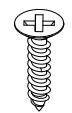

Step 14

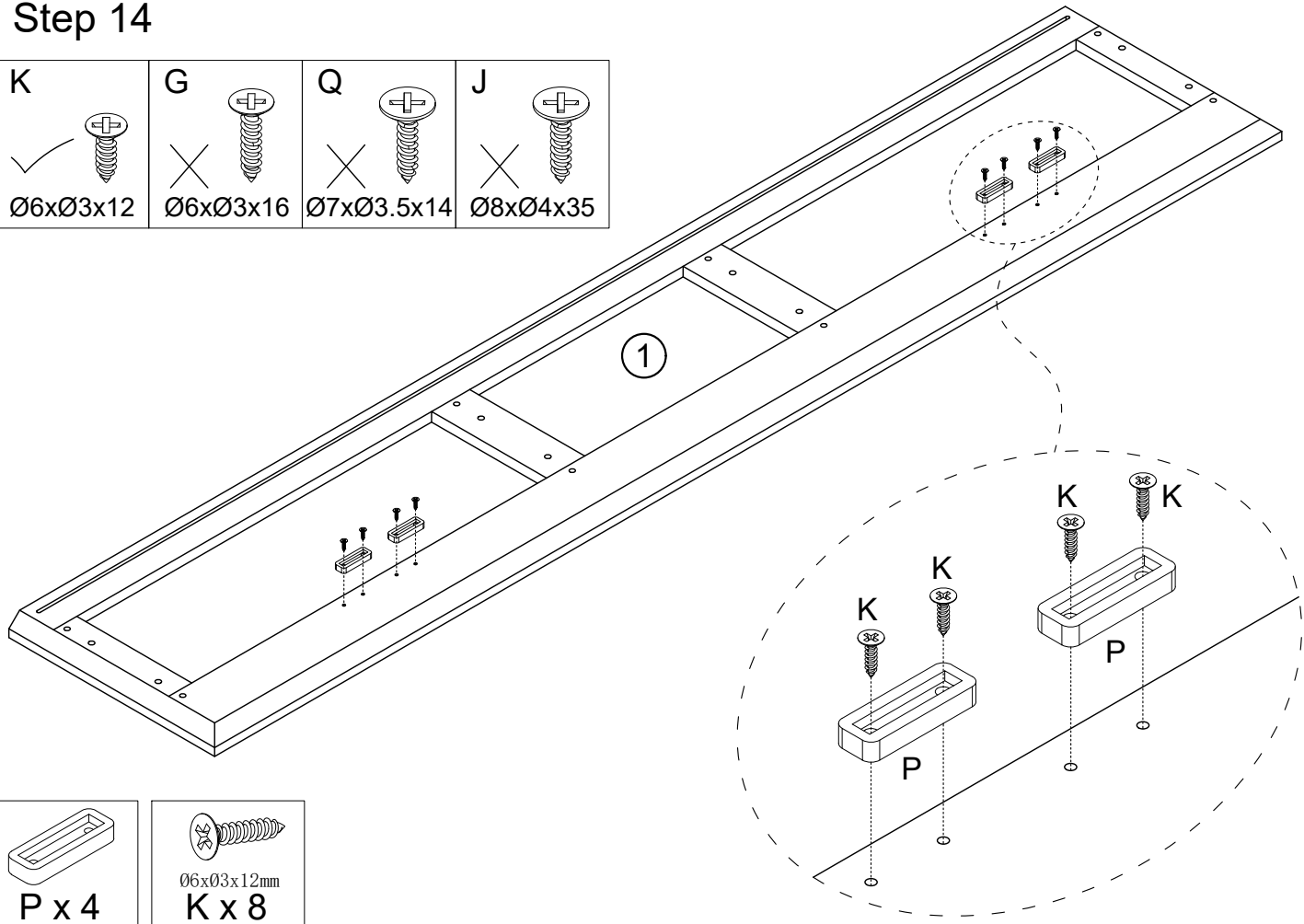

K  ✓ Ø6xØ3x12	G  ✗ Ø6xØ3x16	Q  ✗ Ø7xØ3.5x14	J  ✗ Ø8xØ4x35
----------------------------------------------------------------------------------------------------------------	----------------------------------------------------------------------------------------------------------------	------------------------------------------------------------------------------------------------------------------	----------------------------------------------------------------------------------------------------------------

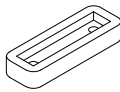
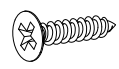

 P x 4	 Ø6xØ3x12mm K x 8
---------------------------------------------------------------------------------------------------	------------------------------------------------------------------------------------------------------------------

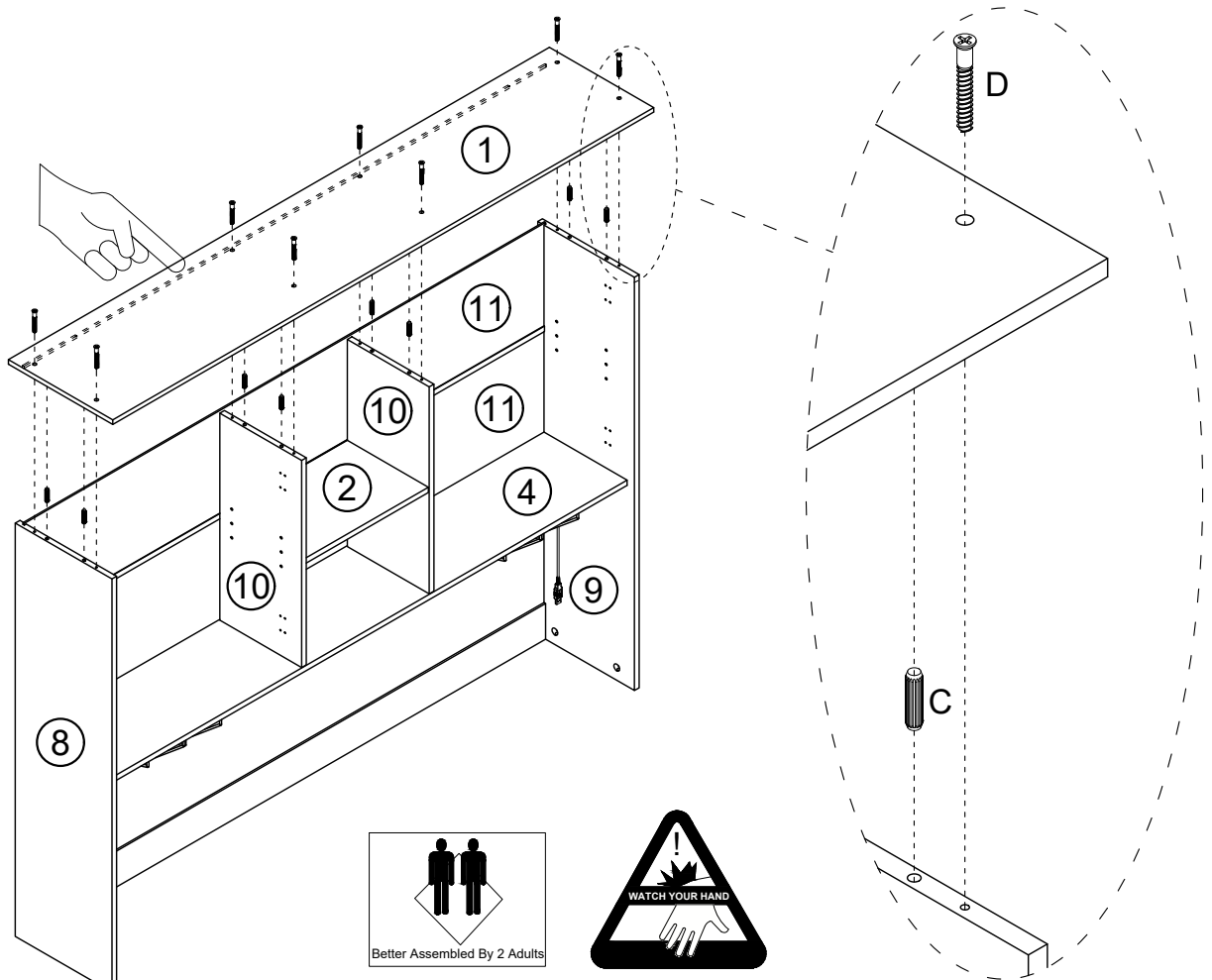
Step 15

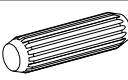

 Ø6x30mm C x 8	 Ø5x38mm D x 8
---------------------------------------------------------------------------------------------------------------	---------------------------------------------------------------------------------------------------------------

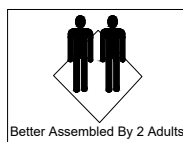

Step 16

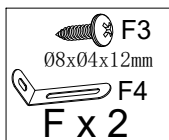
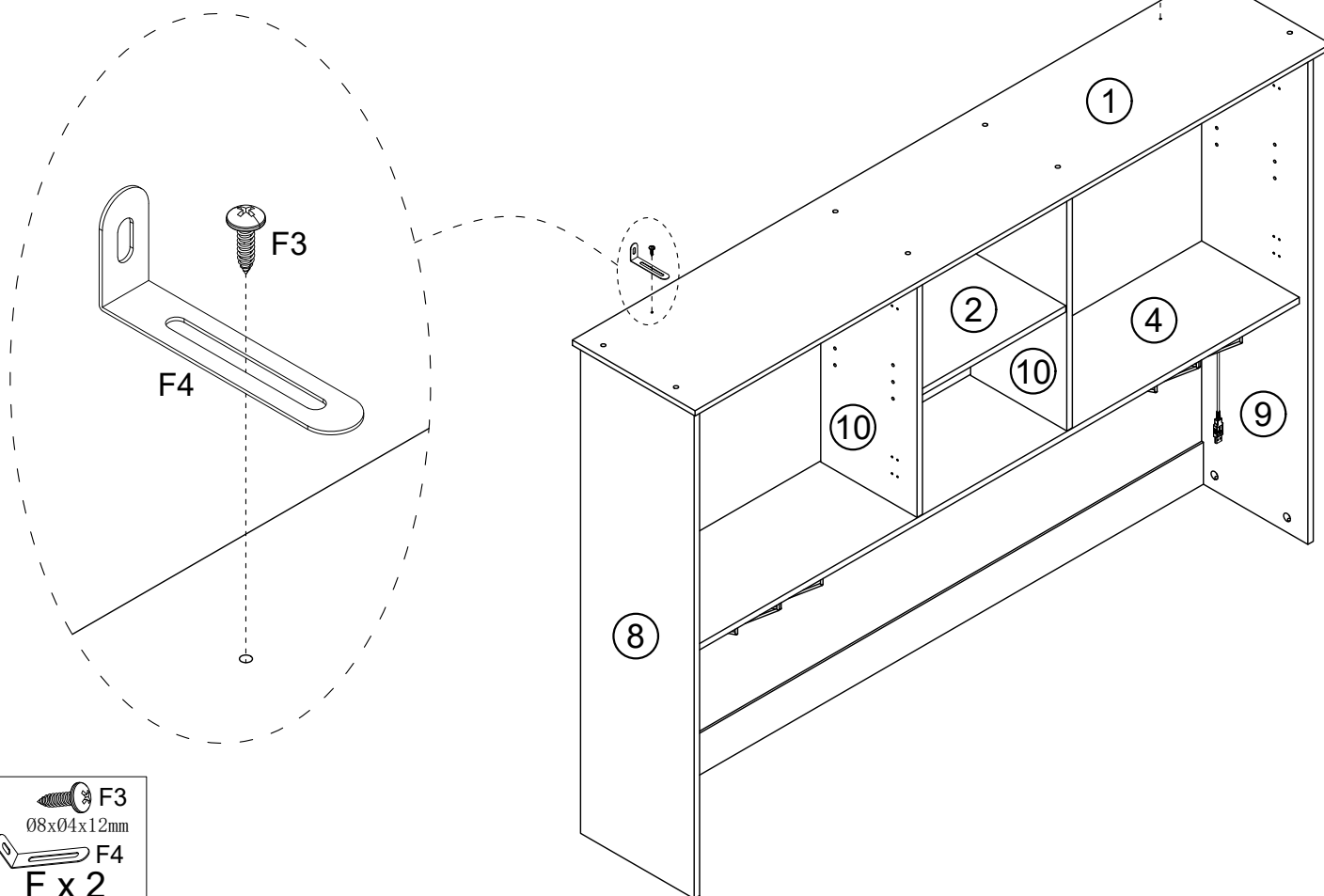

Step 17

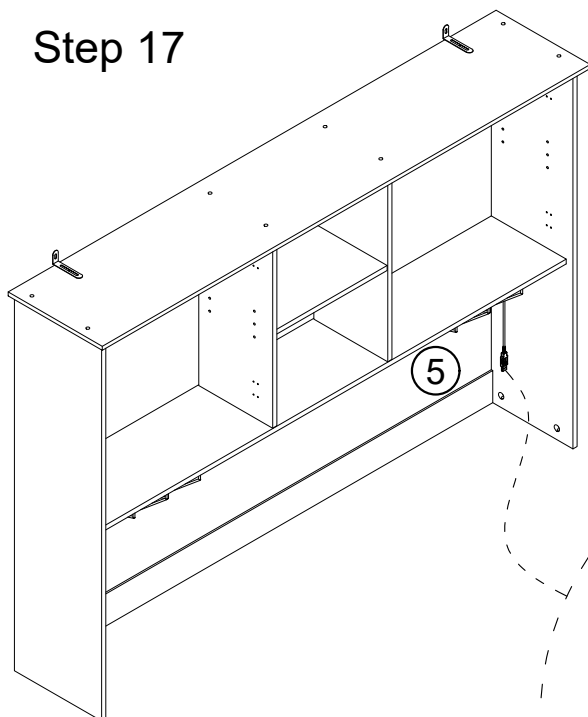

DE: Führen Sie den Lichtstreifen durch diese Position.
UK: Thread the light strip through this position
FR: Faites passer la bande lumineuse à cet endroit.
IT: Fai passare la striscia luminosa attraverso questa posizione.
ES: Pase la tira de luces por esta posición.
NL: Rijg de lichtstrip door deze positie.
SE: Trä ljusremsan genom denna position.
PL: Przelóż pasek świetlny przez to miejsce.

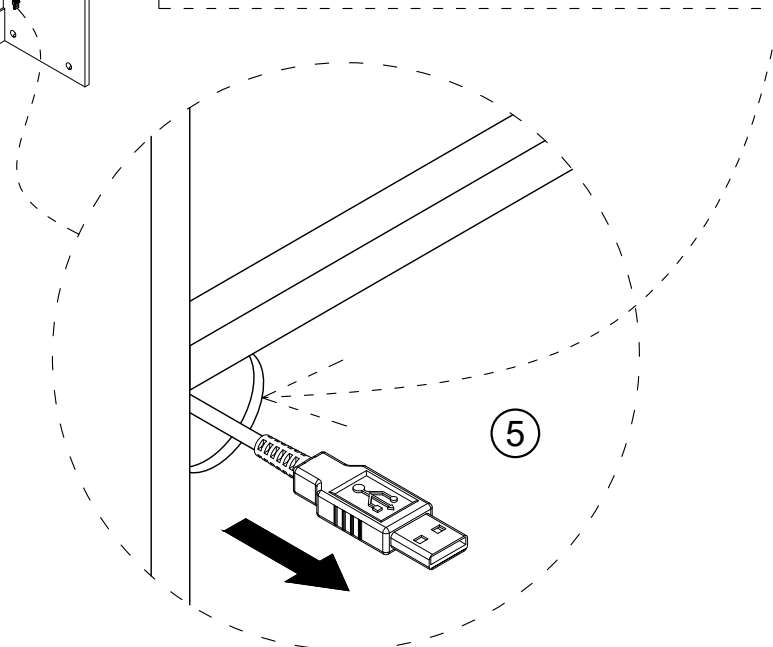

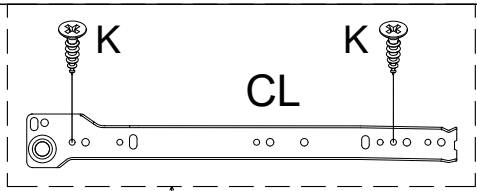

Step 18

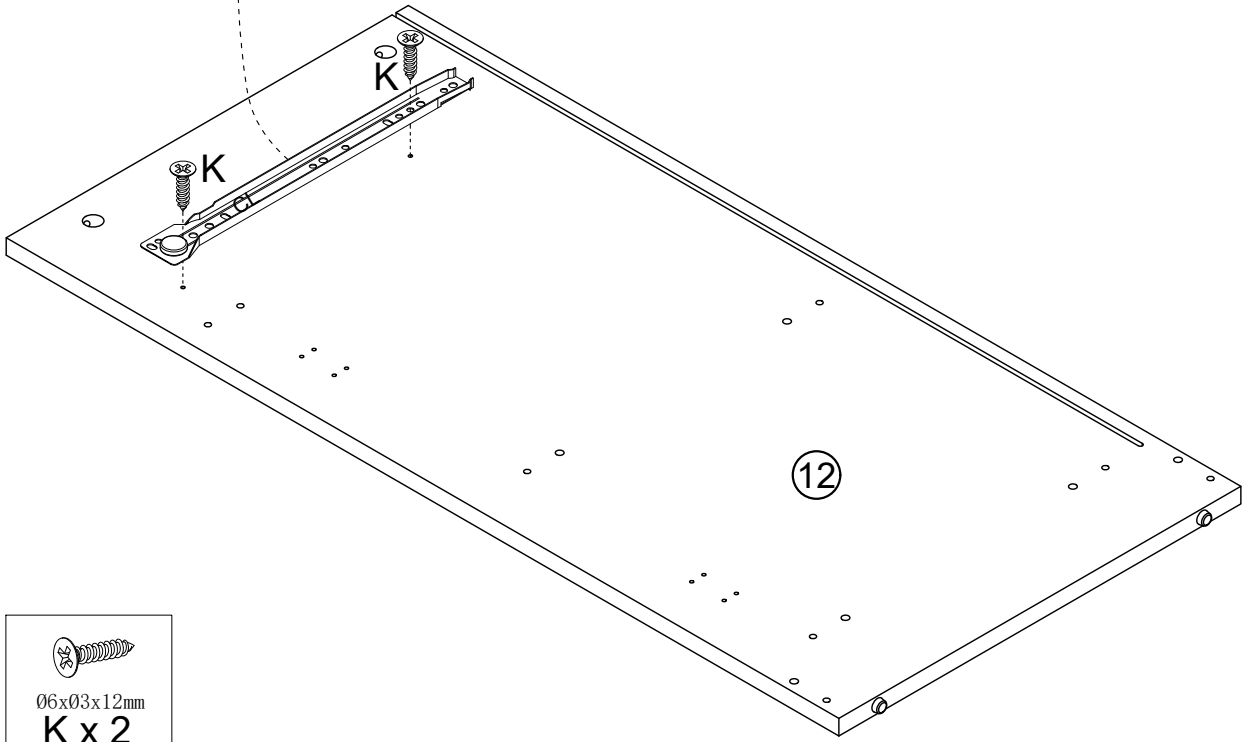

K ✓ Ø6xØ3x12	G ✗ Ø6xØ3x16	Q ✗ Ø7xØ3.5x14	J ✗ Ø8xØ4x35
---------------------------	---------------------------	-----------------------------	---------------------------



 CL x 1 300MM	 Ø6xØ3x12mm K x 2
------------------------------------------------------------------------------------------------------	-----------------------------------------------------------------------------------------------------------

Step 19

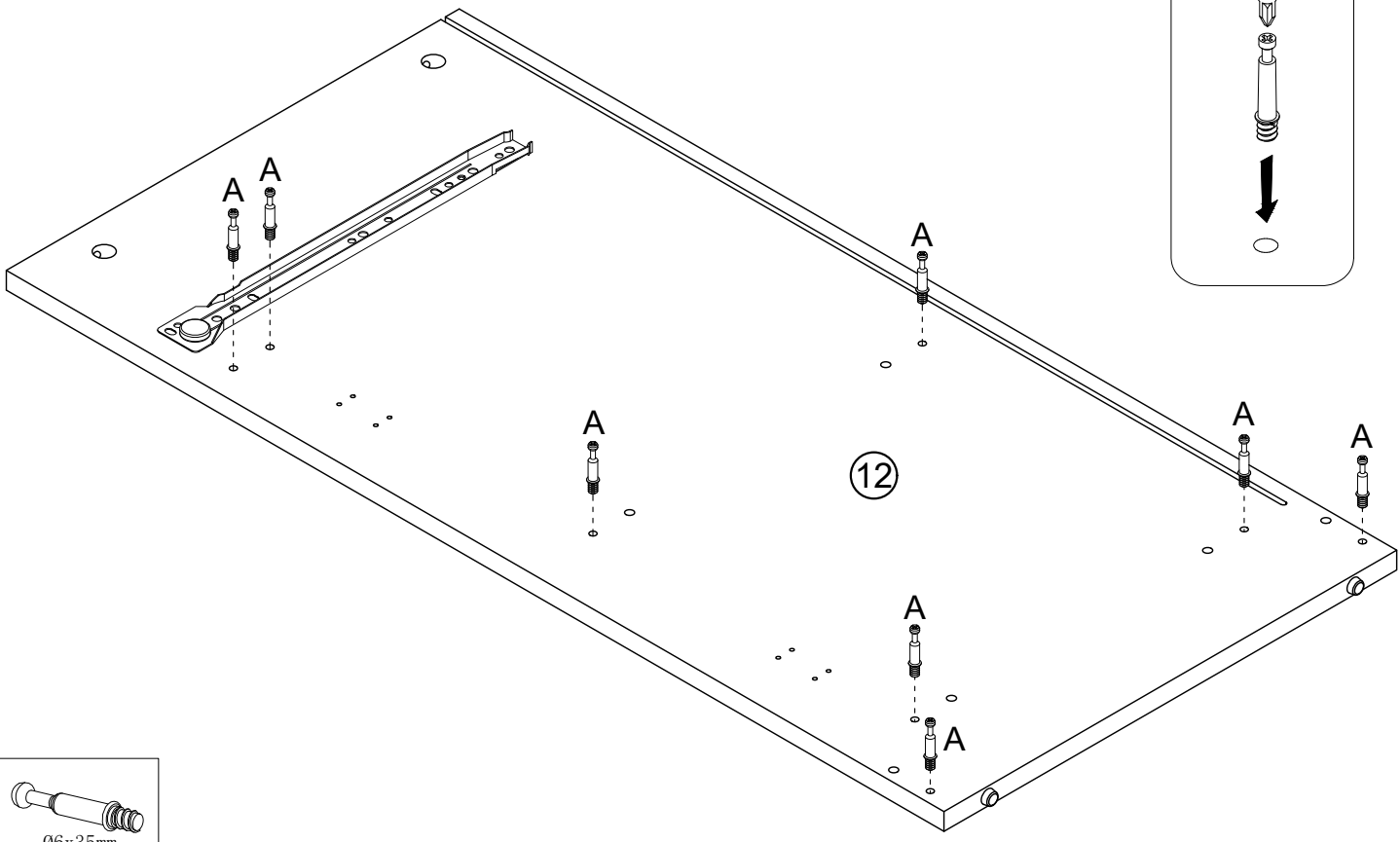
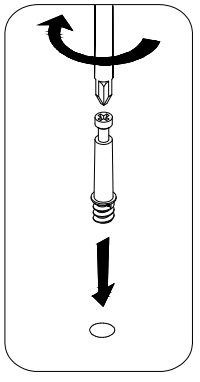

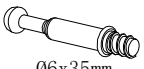
 Ø6x35mm A x 8

Step 20

K ✓ Ø6xØ3x12	G ✗ Ø6xØ3x16	Q ✗ Ø7xØ3.5x14	J ✗ Ø8xØ4x35
---------------------------	---------------------------	-----------------------------	---------------------------

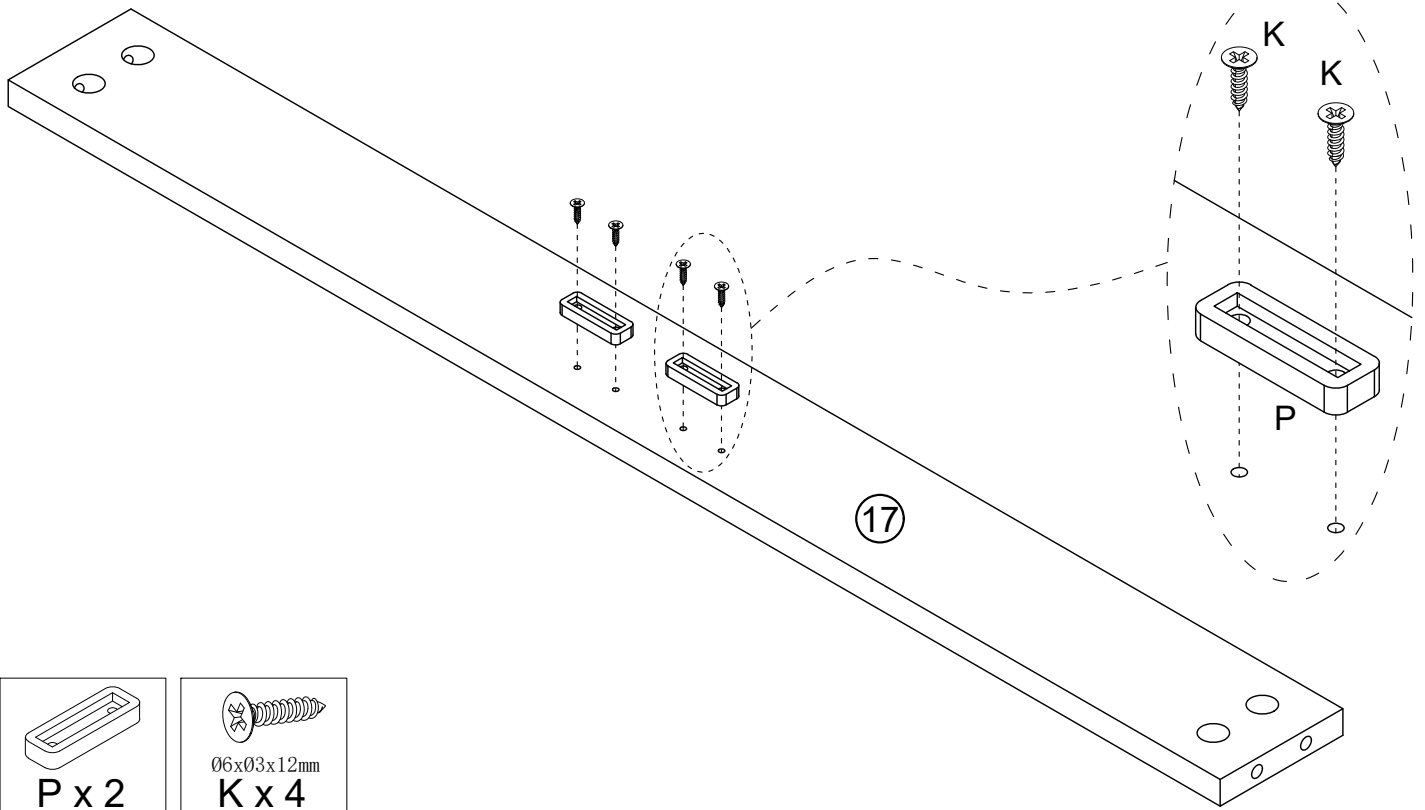

Step 21

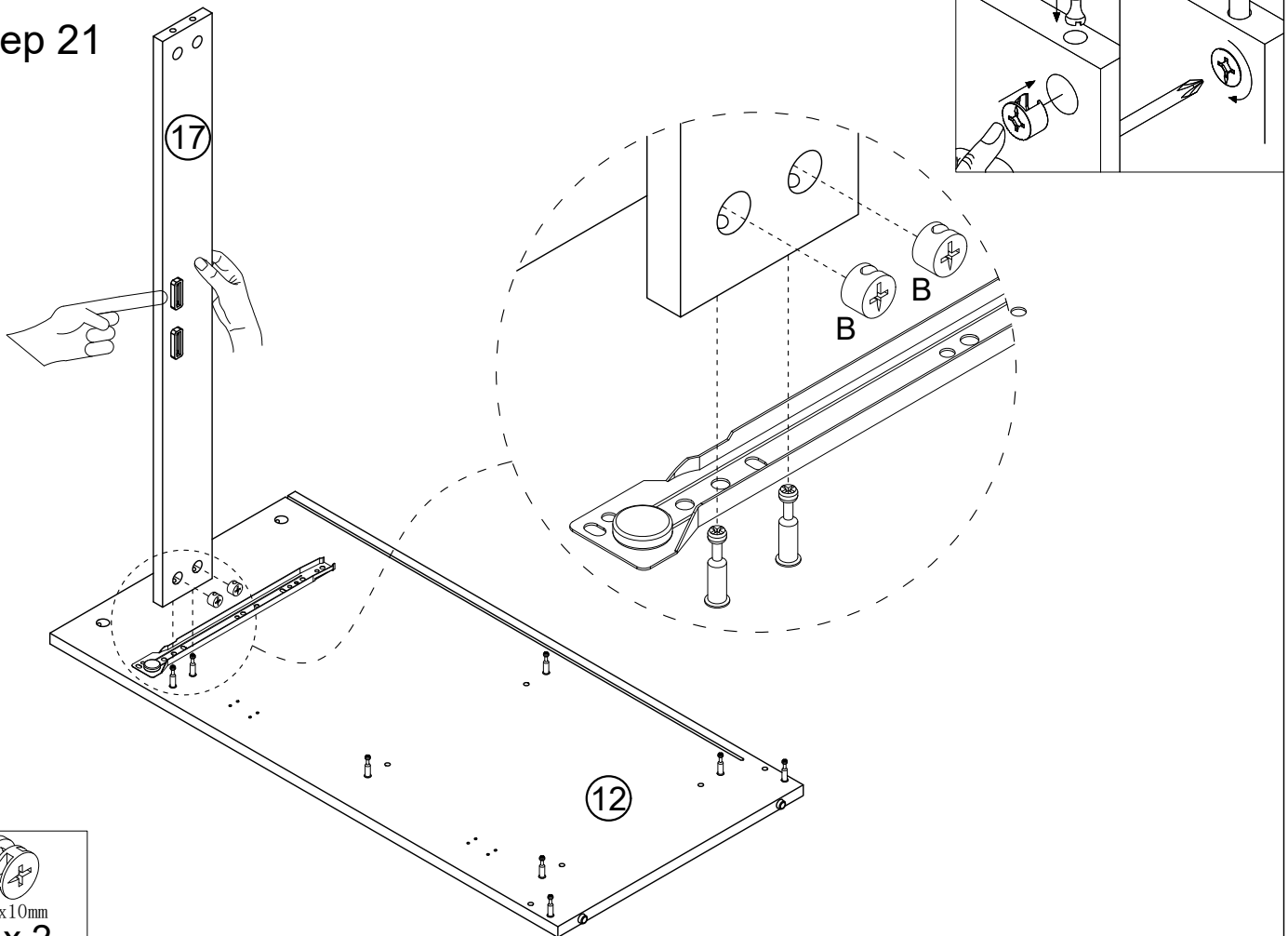

Step 22

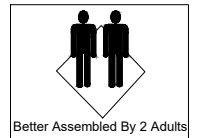
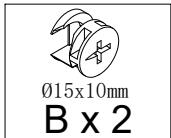
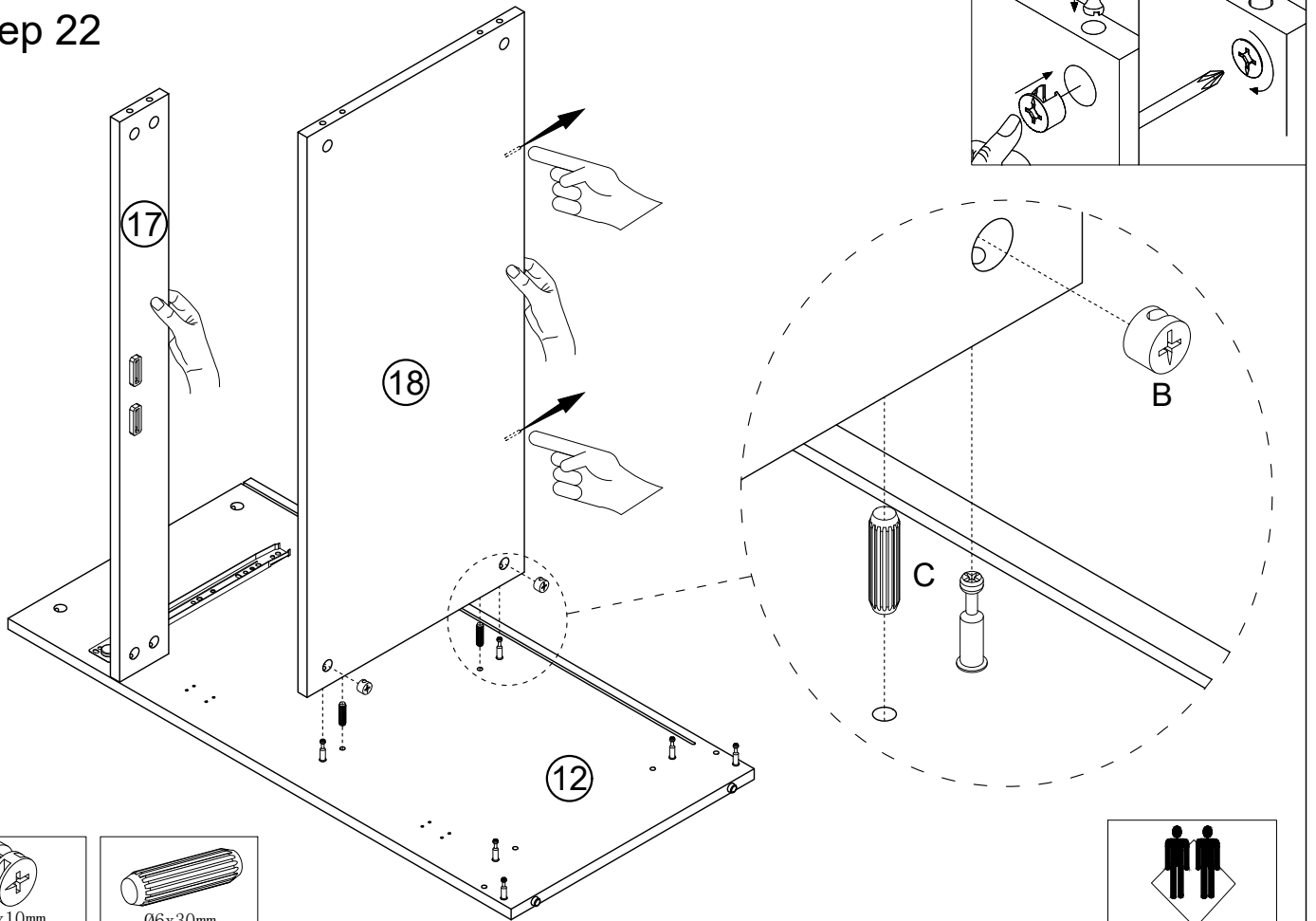

Step 23

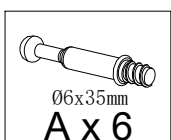
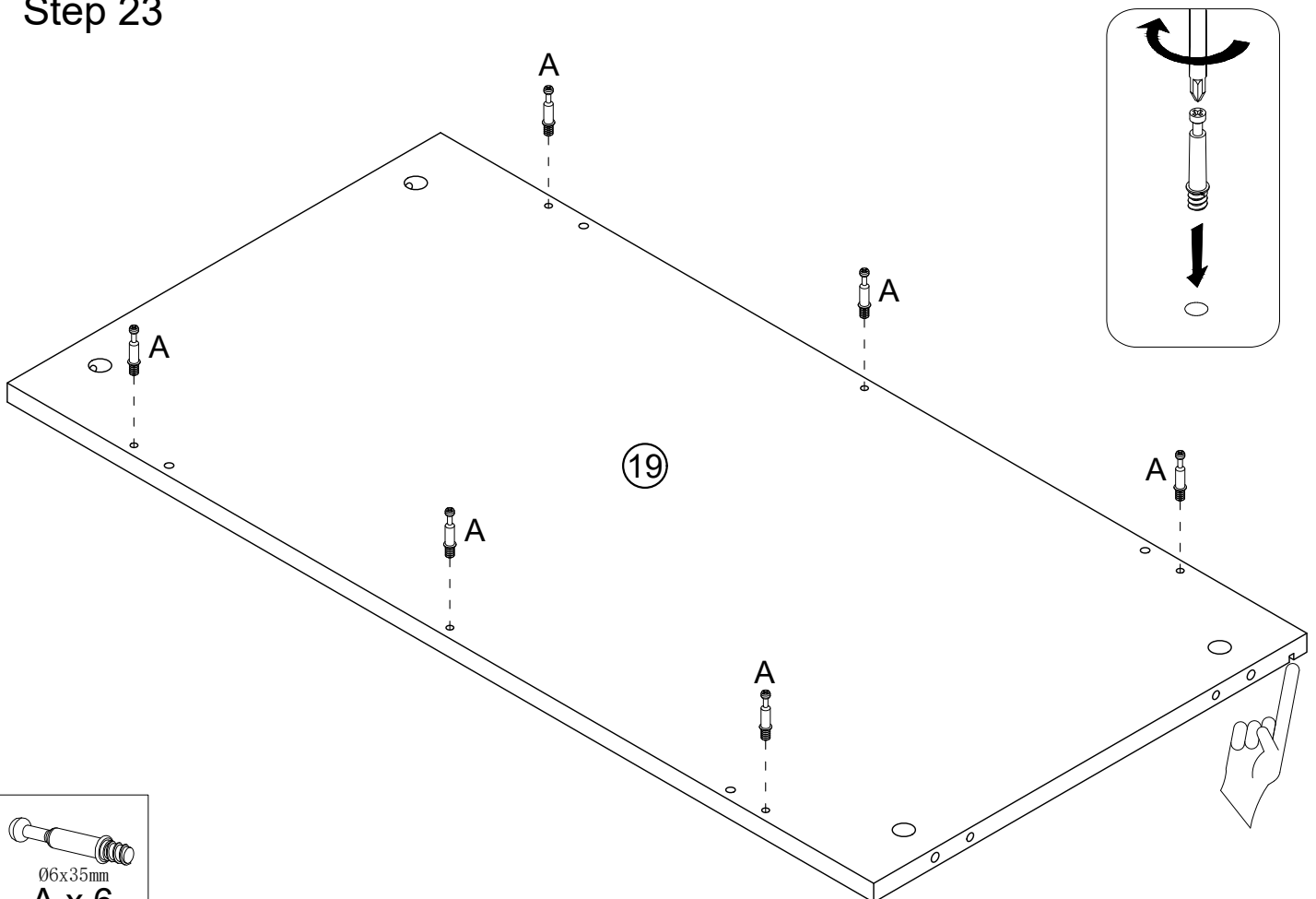

Step 24

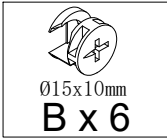
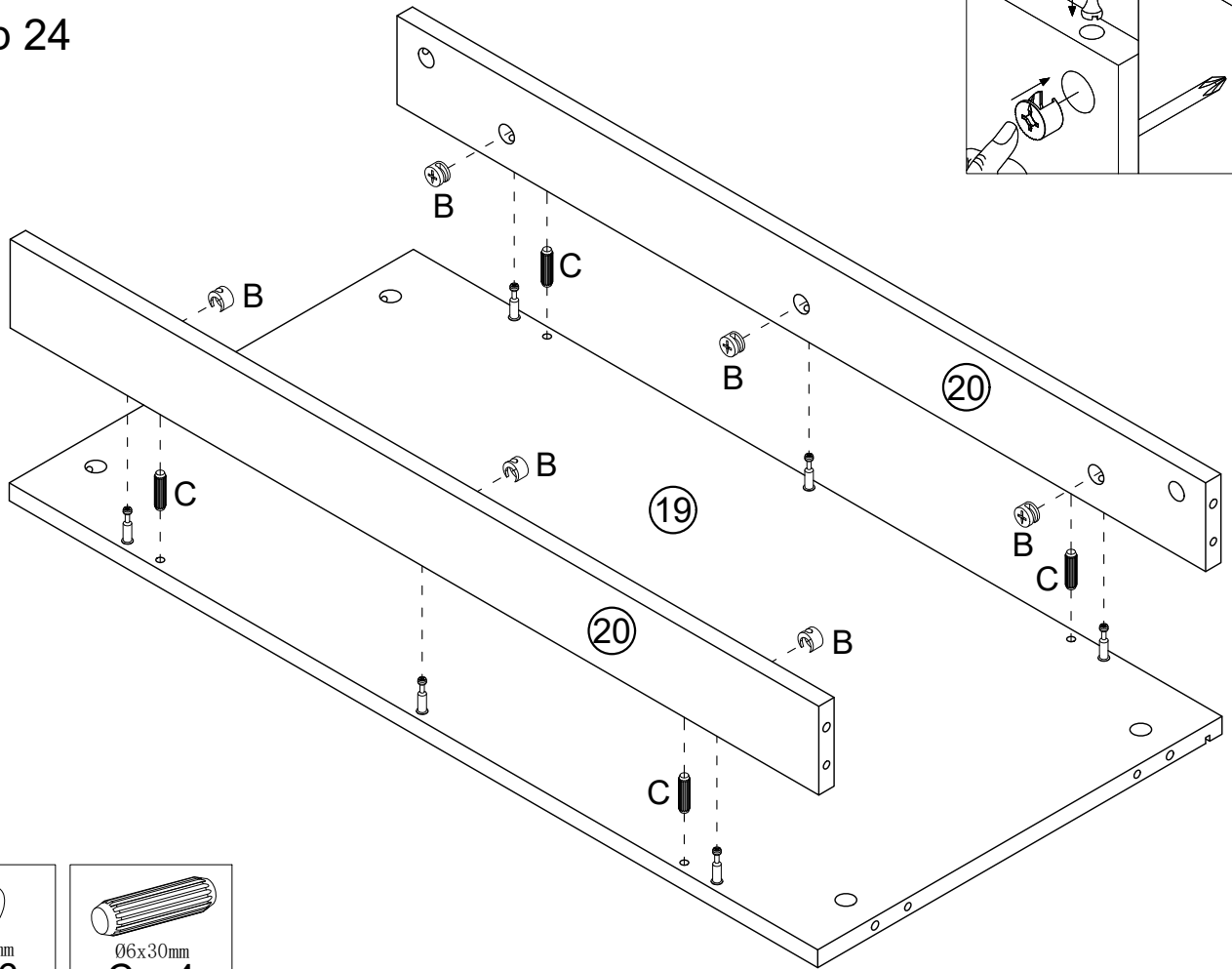

Step 25

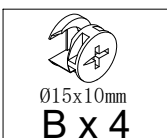
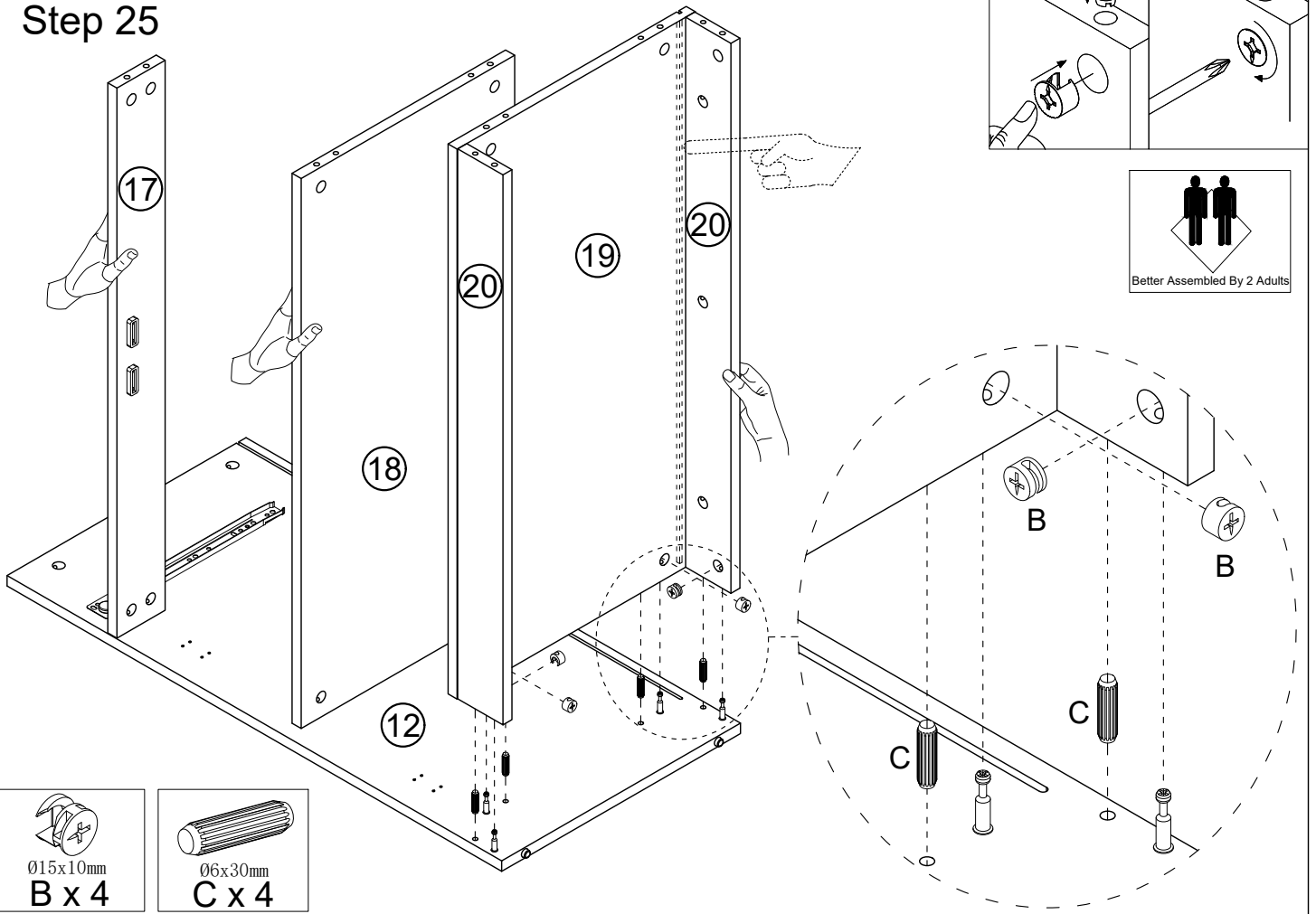

Step 26

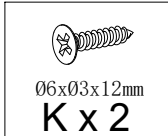
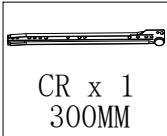
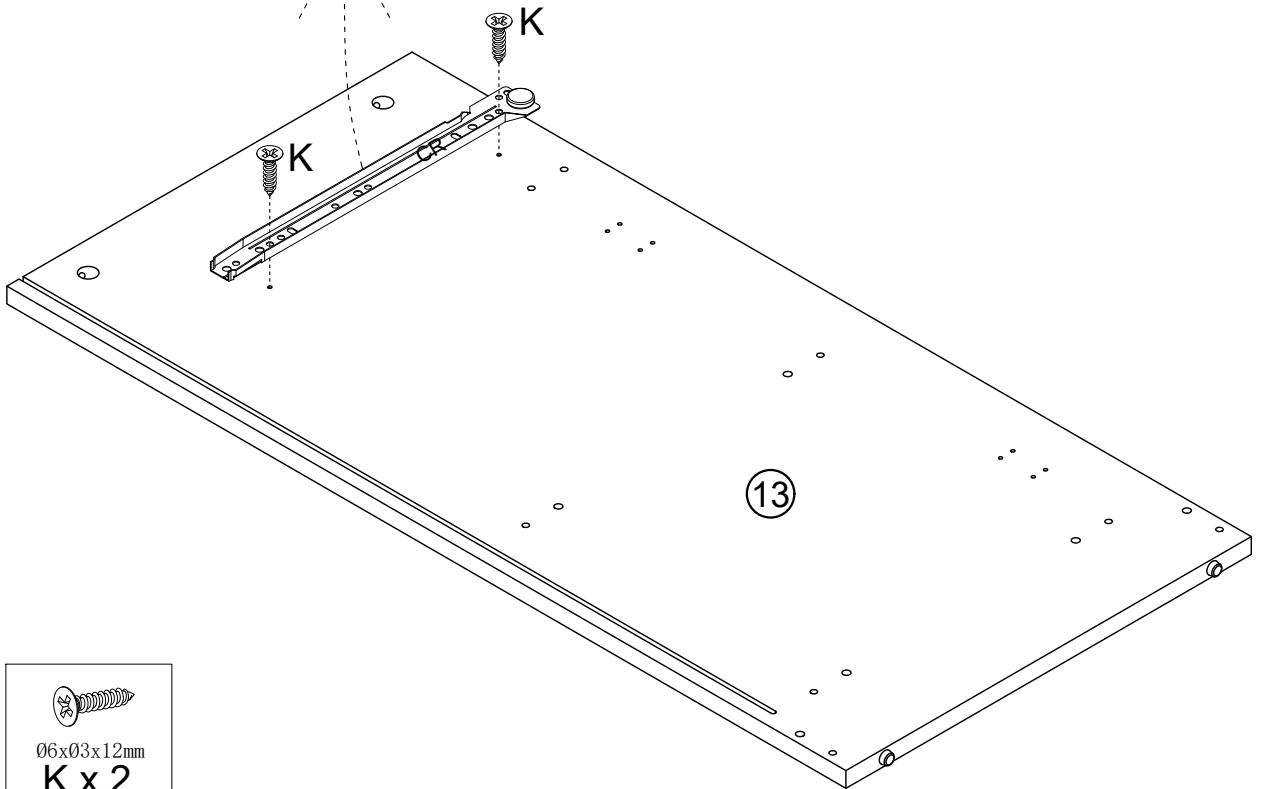
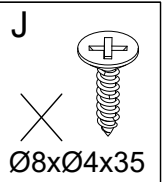
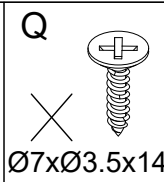
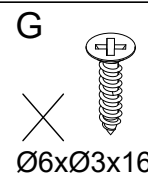
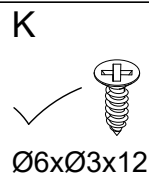

Step 27

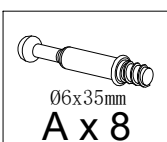
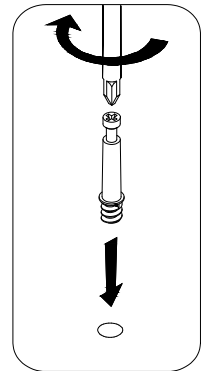
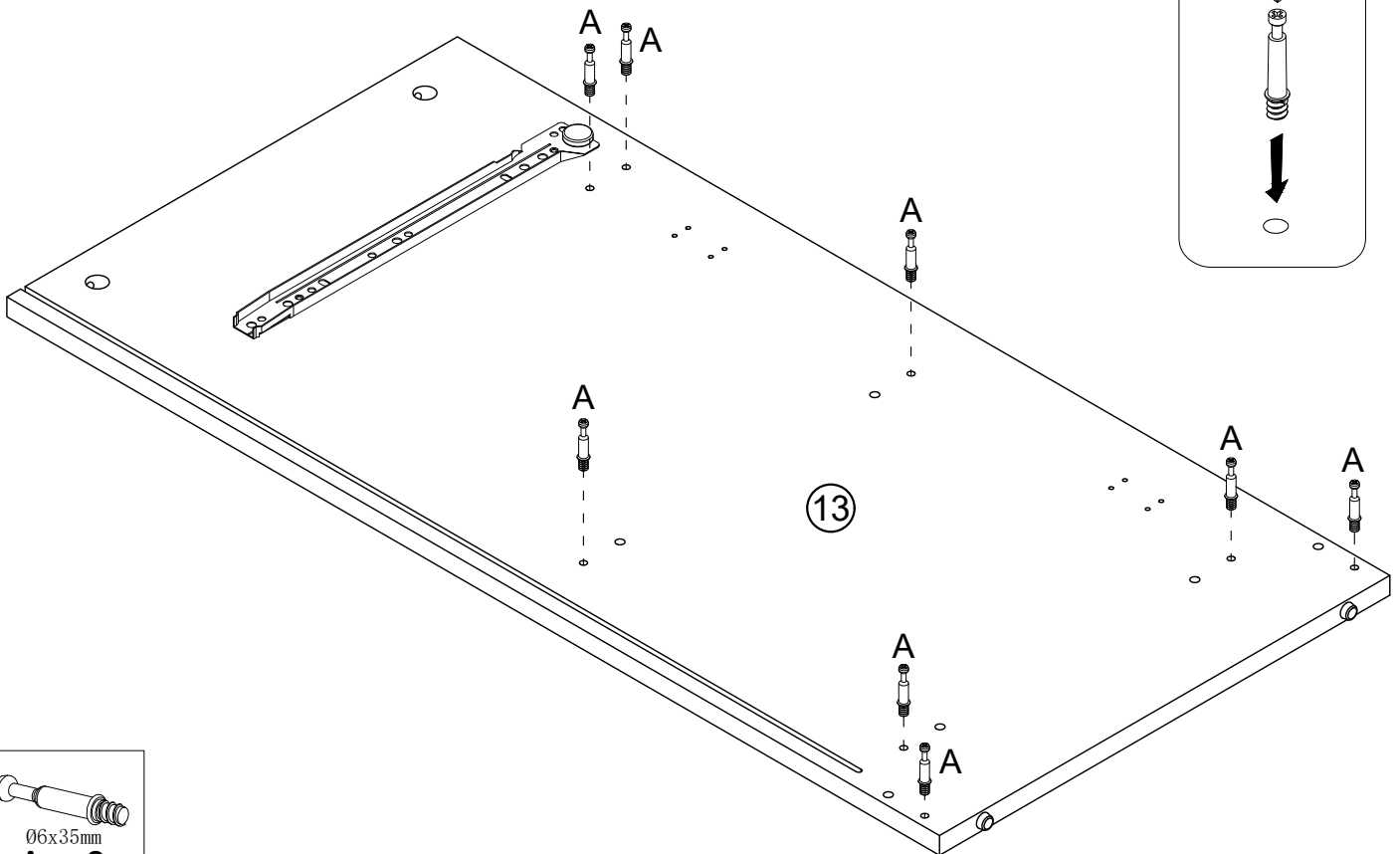

Step 28

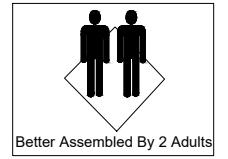
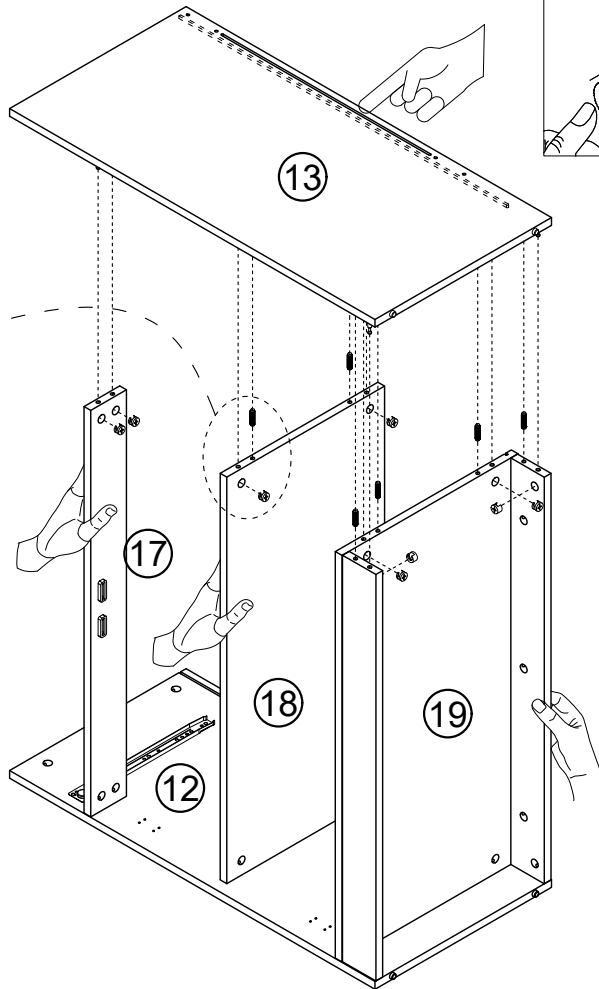
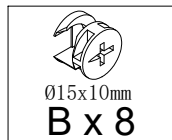
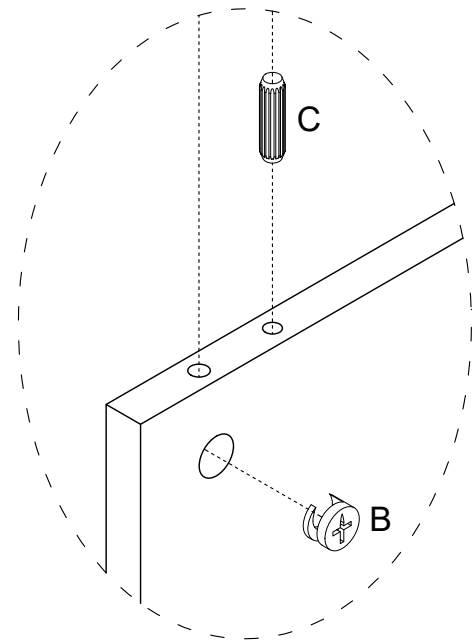

Step 29

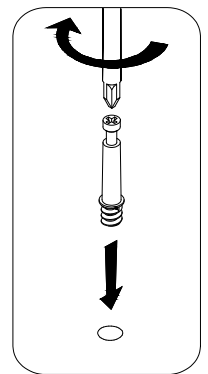
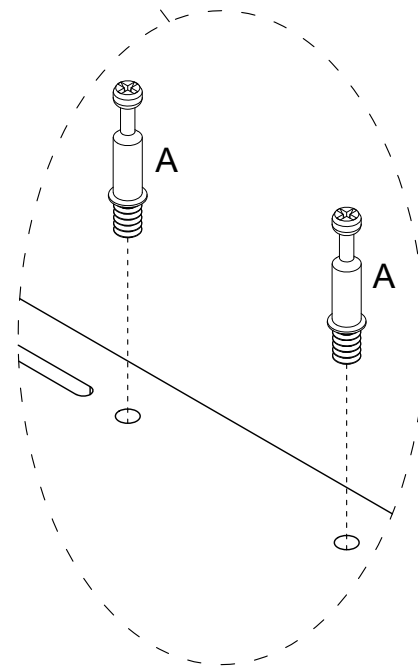
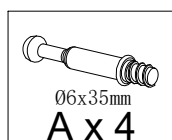
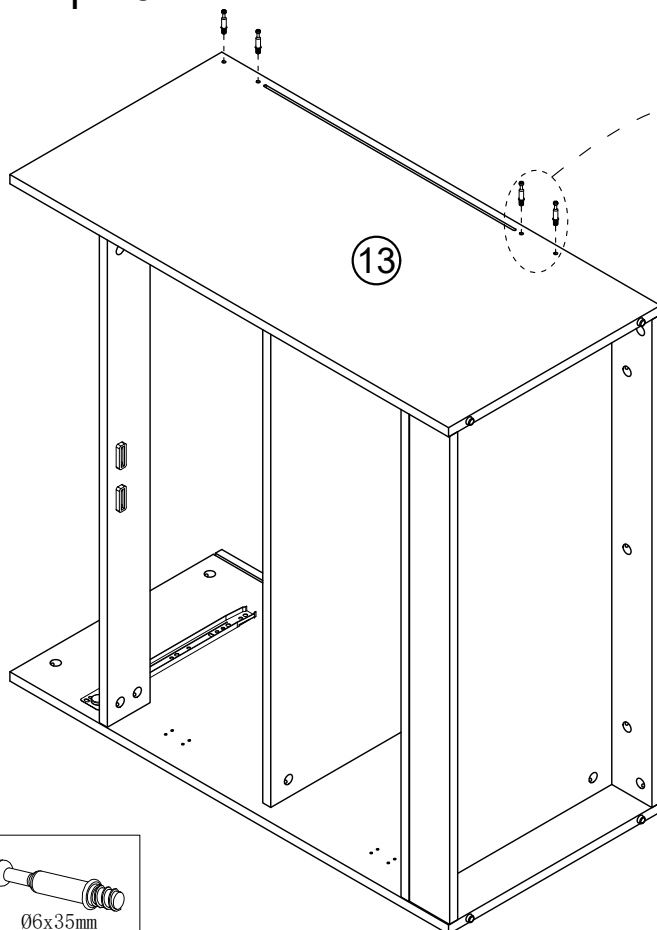

Step 30

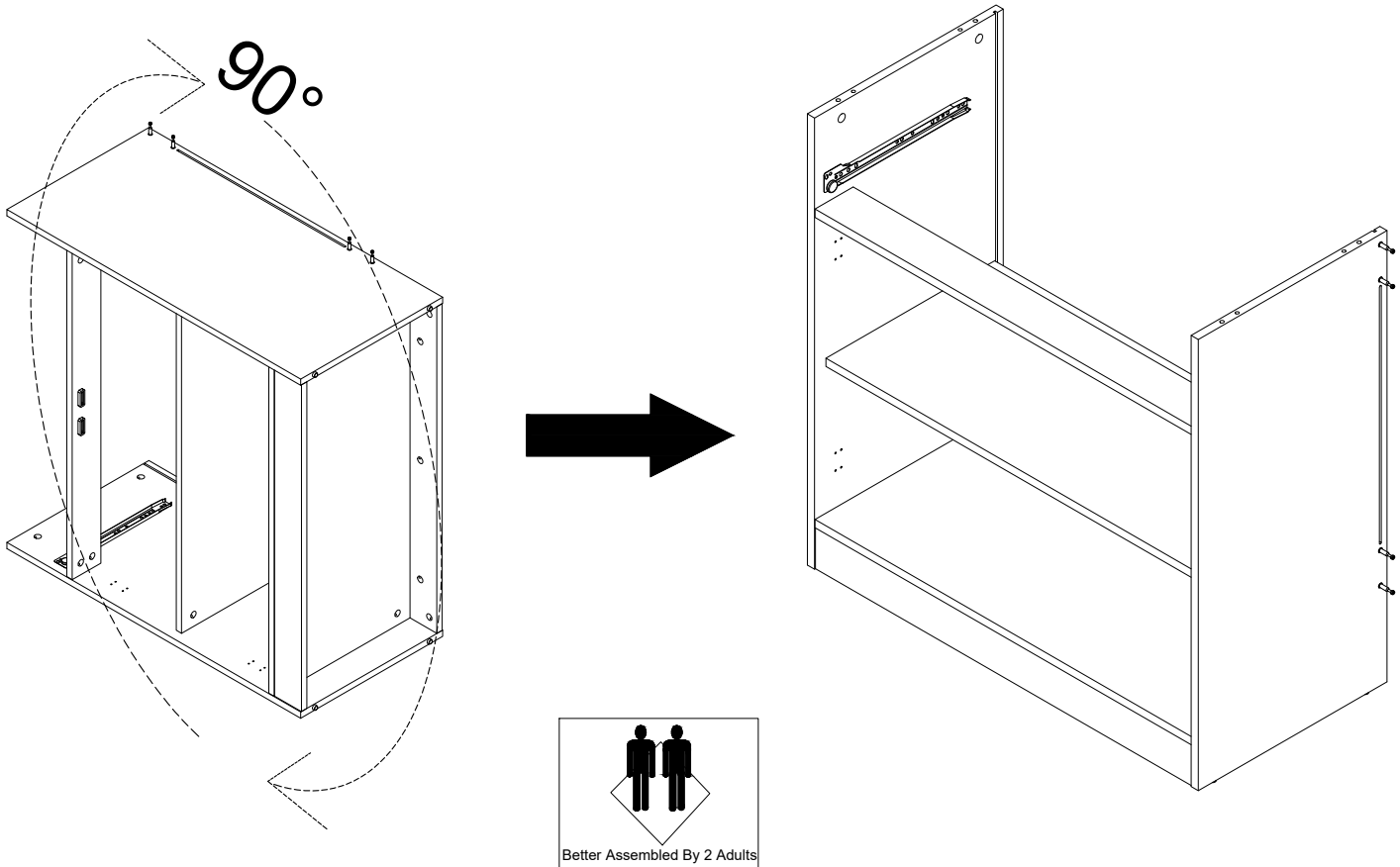

Step 31

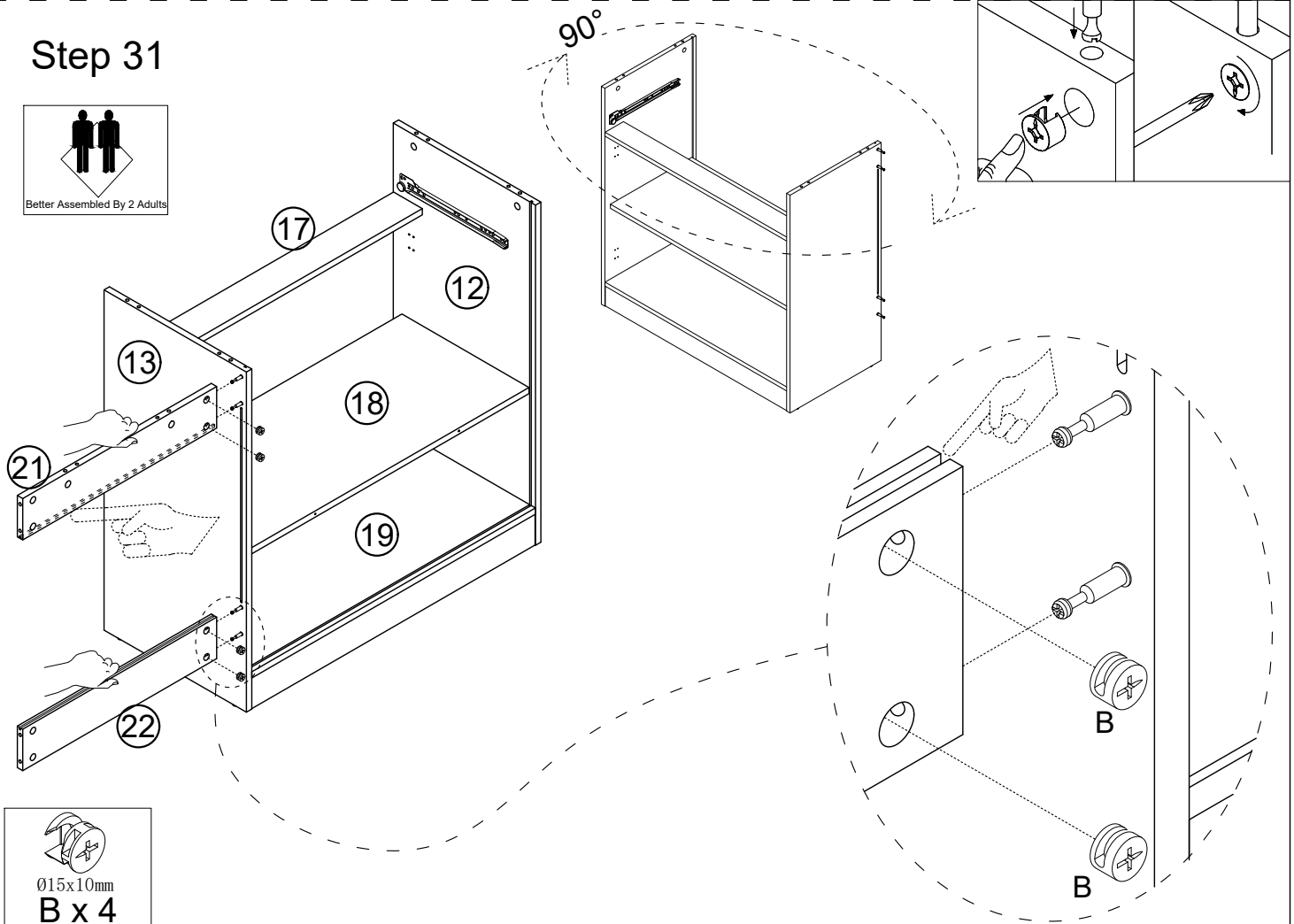

Step 32

DE: Die dünne Platte muss vollständig in die Nut eingeführt werden. Wenn das Einführen nicht reibungslos verläuft, können Sie versuchen, von vorne oder von hinten Druck auszuüben, um Anpassungen vorzunehmen, bis die dünne Platte vollständig in die Nut eingeführt ist.

UK: The thin plate needs to be fully inserted into the groove. If the insertion is not smooth, you can try pressing from the front or the back to make adjustments until the thin plate is fully inserted into the groove.

FR: La plaque mince doit être entièrement insérée dans la rainure. Si l'insertion ne se fait pas facilement, vous pouvez essayer d'appuyer à l'avant ou à l'arrière pour ajuster la plaque jusqu'à ce qu'elle soit entièrement insérée dans la rainure.

IT: La piastra sottile deve essere inserita completamente nella scanalatura. Se l'inserimento non avviene in modo fluido, è possibile provare a premere dalla parte anteriore o posteriore per effettuare le regolazioni necessarie fino a quando la piastra sottile non è inserita completamente nella scanalatura.

ES: La placa delgada debe insertarse completamente en la ranura. Si la inserción no es fluida, puede intentar presionar desde la parte delantera o trasera para realizar ajustes hasta que la placa delgada se inserte completamente en la ranura.

NL: De dunne plaat moet volledig in de groef worden gestoken. Als het insteken niet soepel verloopt, kunt u proberen vanaf de voorkant of de achterkant druk uit te oefenen om aanpassingen te maken totdat de dunne plaat volledig in de groef is gestoken.

SE: Den tunna plattan måste sättas in helt i spåret. Om den inte går in smidigt kan du försöka trycka från framsidan eller baksidan för att justera tills den tunna plattan är helt insatt i spåret.

PL: Cienką płytkę należy całkowicie wsunąć w rowek. Jeśli wsuwanie nie przebiega płynnie, można spróbować docisnąć ją od przodu lub od tyłu, dopasowując ją tak, aby całkowicie wsunęła się w rowek.

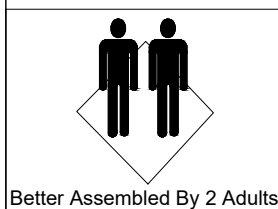
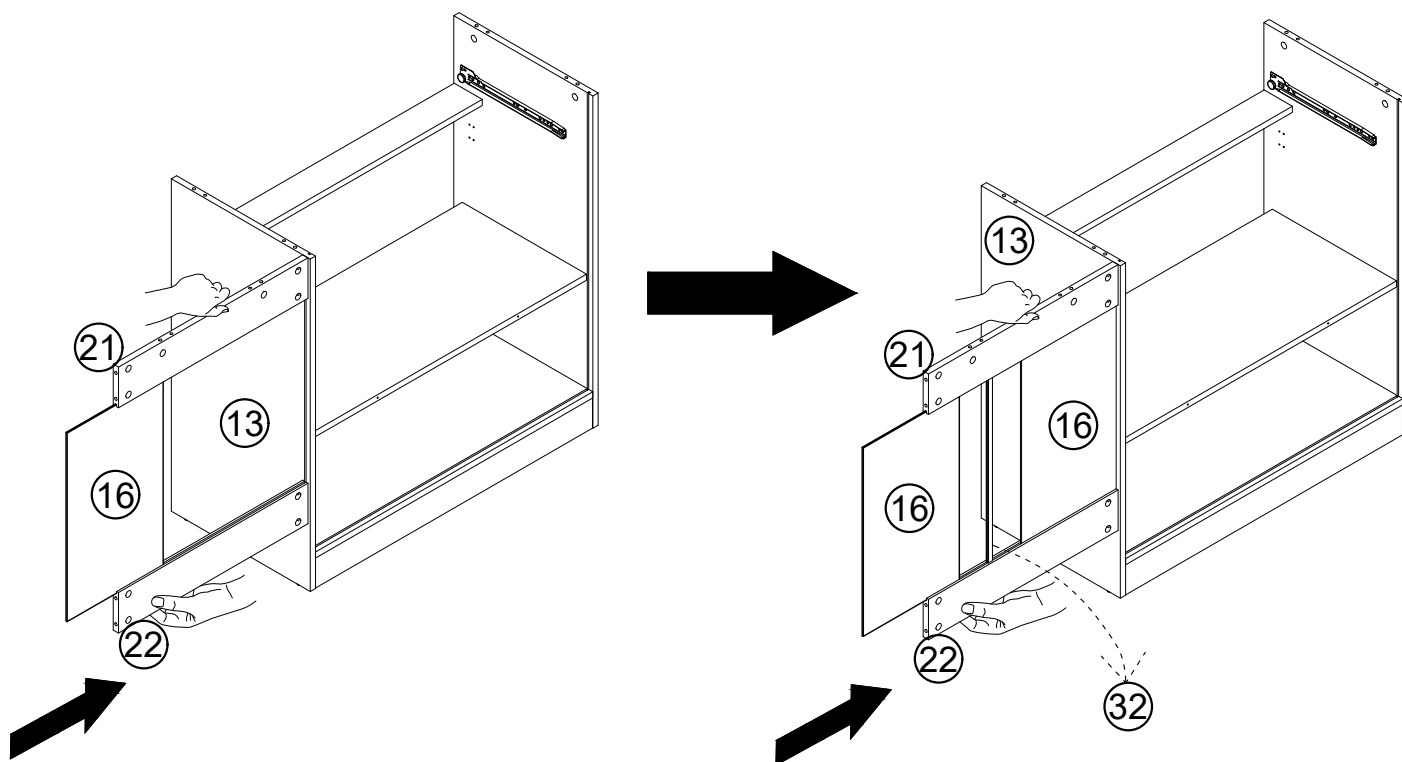

Step 33

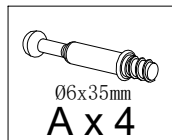
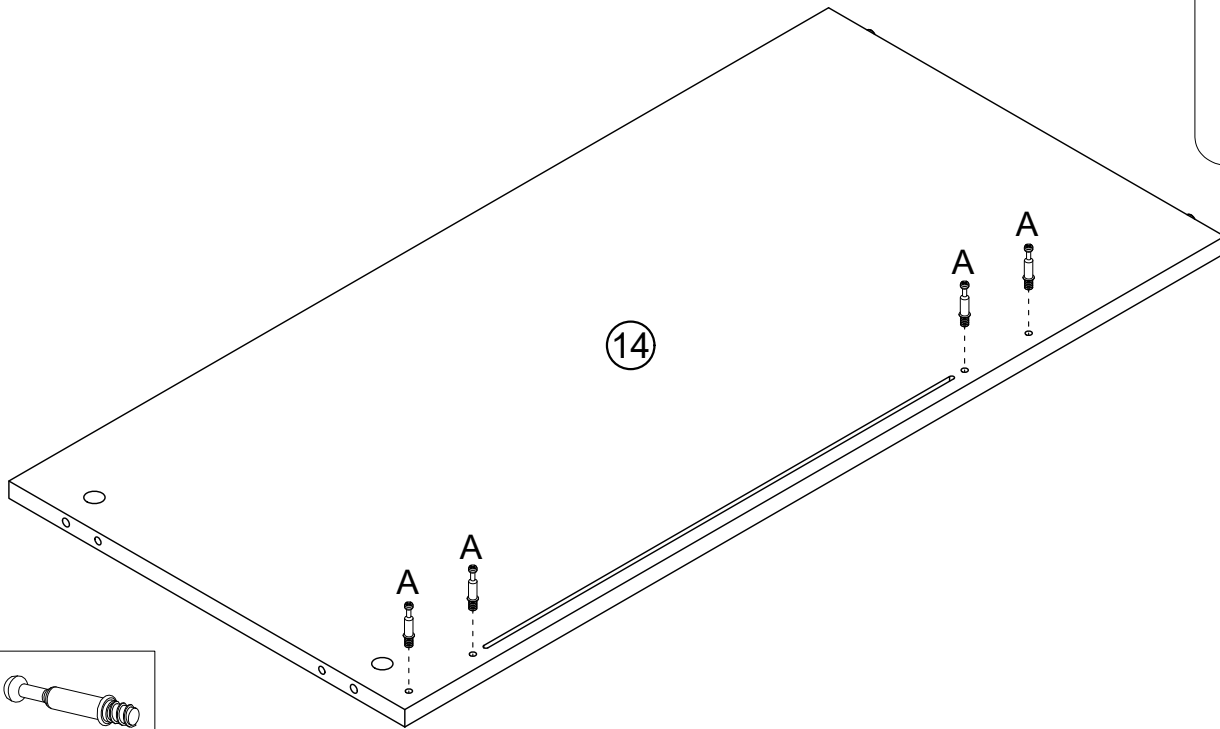

Step 34

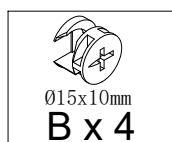
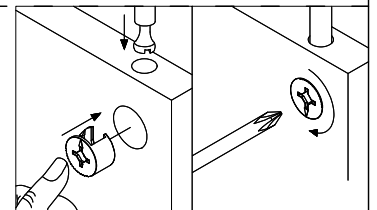
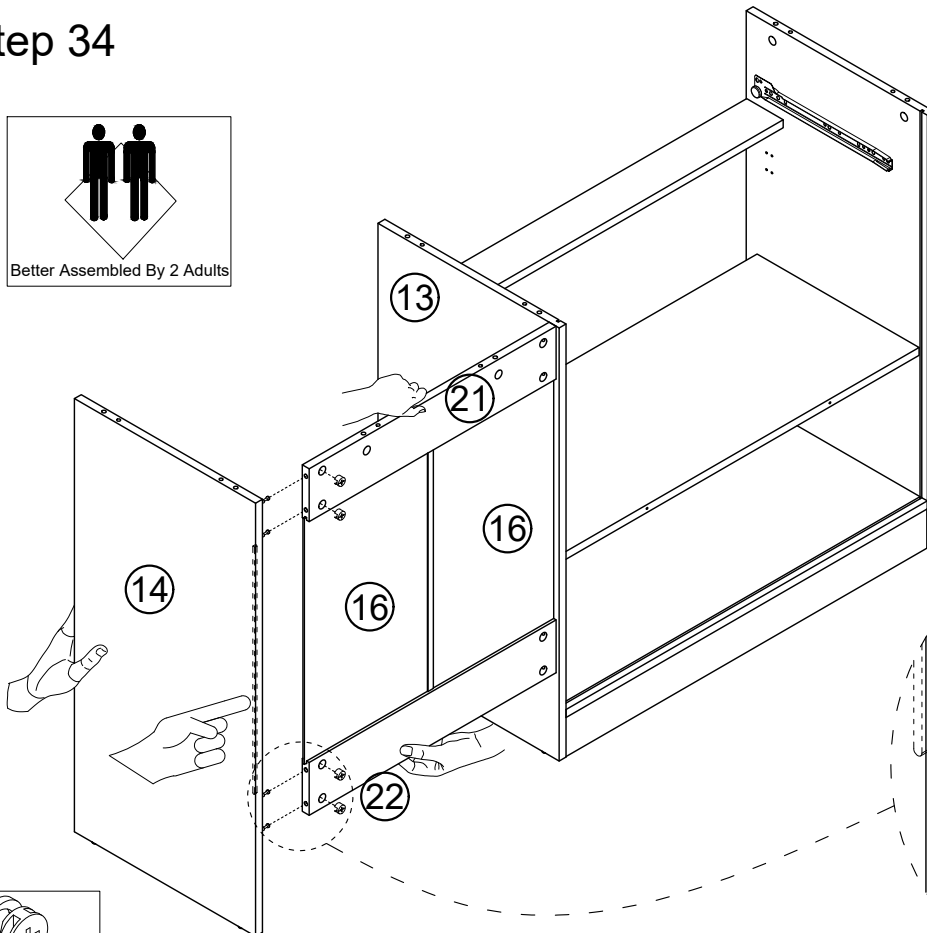
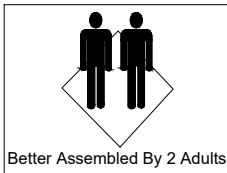

Step 35

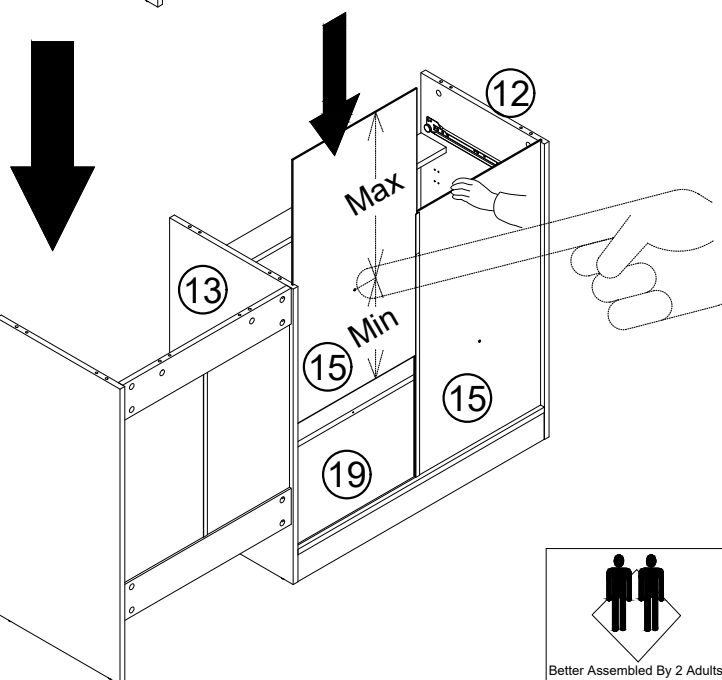
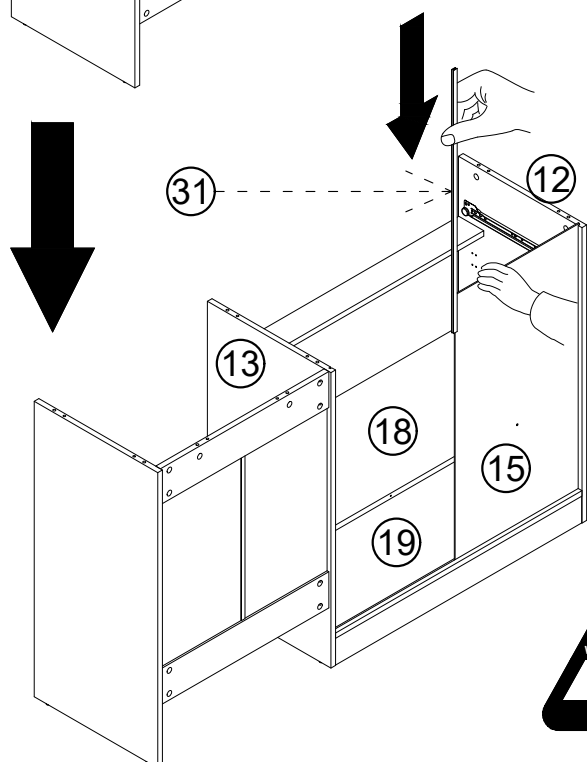
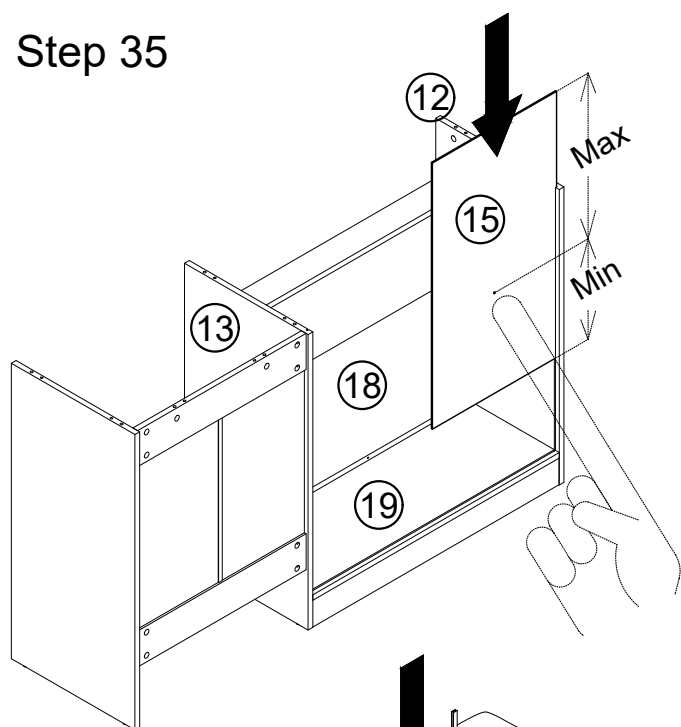

DE: Die dünne Platte muss vollständig in die Nut eingeführt werden. Wenn das Einführen nicht reibungslos verläuft, können Sie versuchen, von vorne oder von hinten Druck auszuüben, um Anpassungen vorzunehmen, bis die dünne Platte vollständig in die Nut eingeführt ist.

UK: The thin plate needs to be fully inserted into the groove. If the insertion is not smooth, you can try pressing from the front or the back to make adjustments until the thin plate is fully inserted into the groove.

FR: La plaque mince doit être entièrement insérée dans la rainure. Si l'insertion ne se fait pas facilement, vous pouvez essayer d'appuyer à l'avant ou à l'arrière pour ajuster la plaque jusqu'à ce qu'elle soit entièrement insérée dans la rainure.

IT: La piastra sottile deve essere inserita completamente nella scanalatura. Se l'inserimento non avviene in modo fluido, è possibile provare a premere dalla parte anteriore o posteriore per effettuare le regolazioni necessarie fino a quando la piastra sottile non è inserita completamente nella scanalatura.

ES: La placa delgada debe insertarse completamente en la ranura. Si la inserción no es fluida, puede intentar presionar desde la parte delantera o trasera para realizar ajustes hasta que la placa delgada se inserte completamente en la ranura.

NL: De dunne plaat moet volledig in de groef worden gestoken. Als het insteken niet soepel verloopt, kunt u proberen vanaf de voorkant of de achterkant druk uit te oefenen om aanpassingen te maken totdat de dunne plaat volledig in de groef is gestoken.

SE: Den tunna plattan måste sättas in helt i spåret. Om den inte går in smidigt kan du försöka trycka från framsidan eller baksidan för att justera tills den tunna plattan är helt insatt i spåret.

PL: Cienką płytkę należy całkowicie wsunąć w rowek. Jeśli wsuwanie nie przebiega płynnie, można spróbować docisnąć ją od przodu lub od tyłu, dopasowując ją tak, aby całkowicie wsunęła się w rowek.

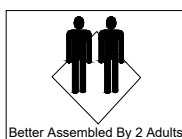

Step 36

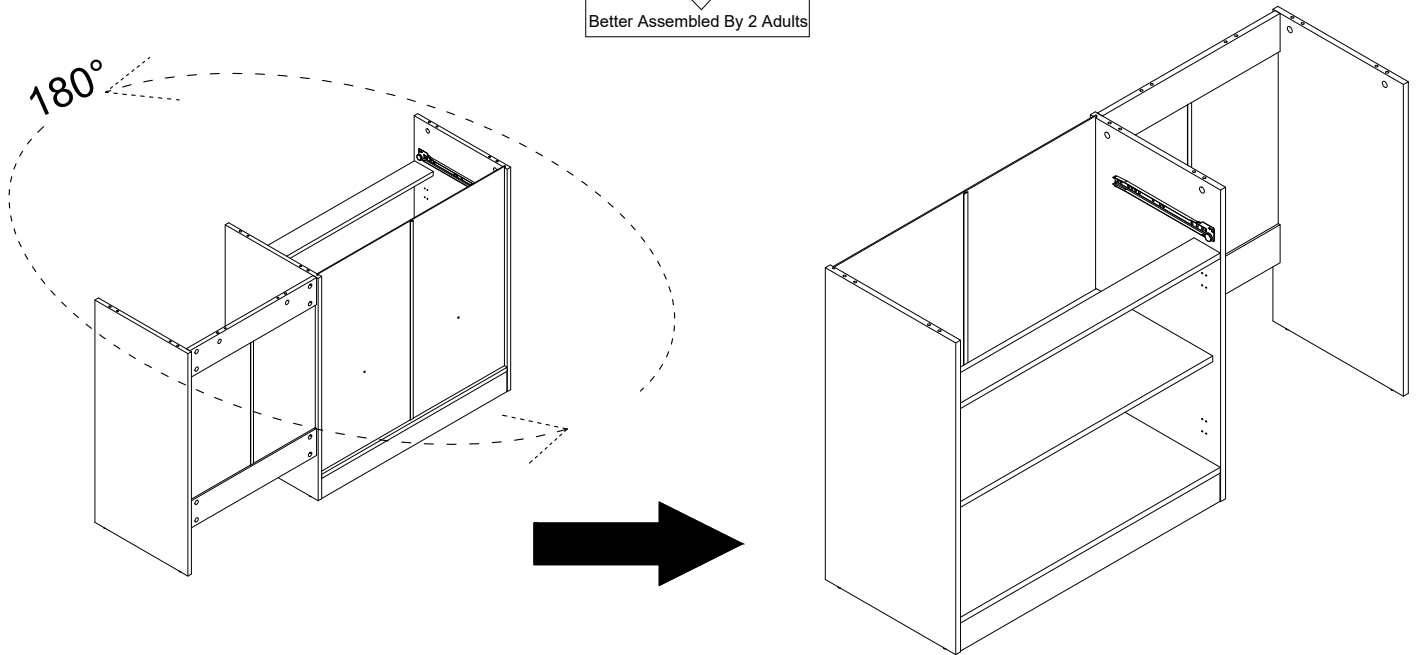
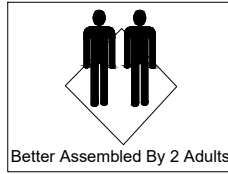

Step 37

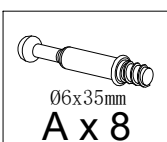
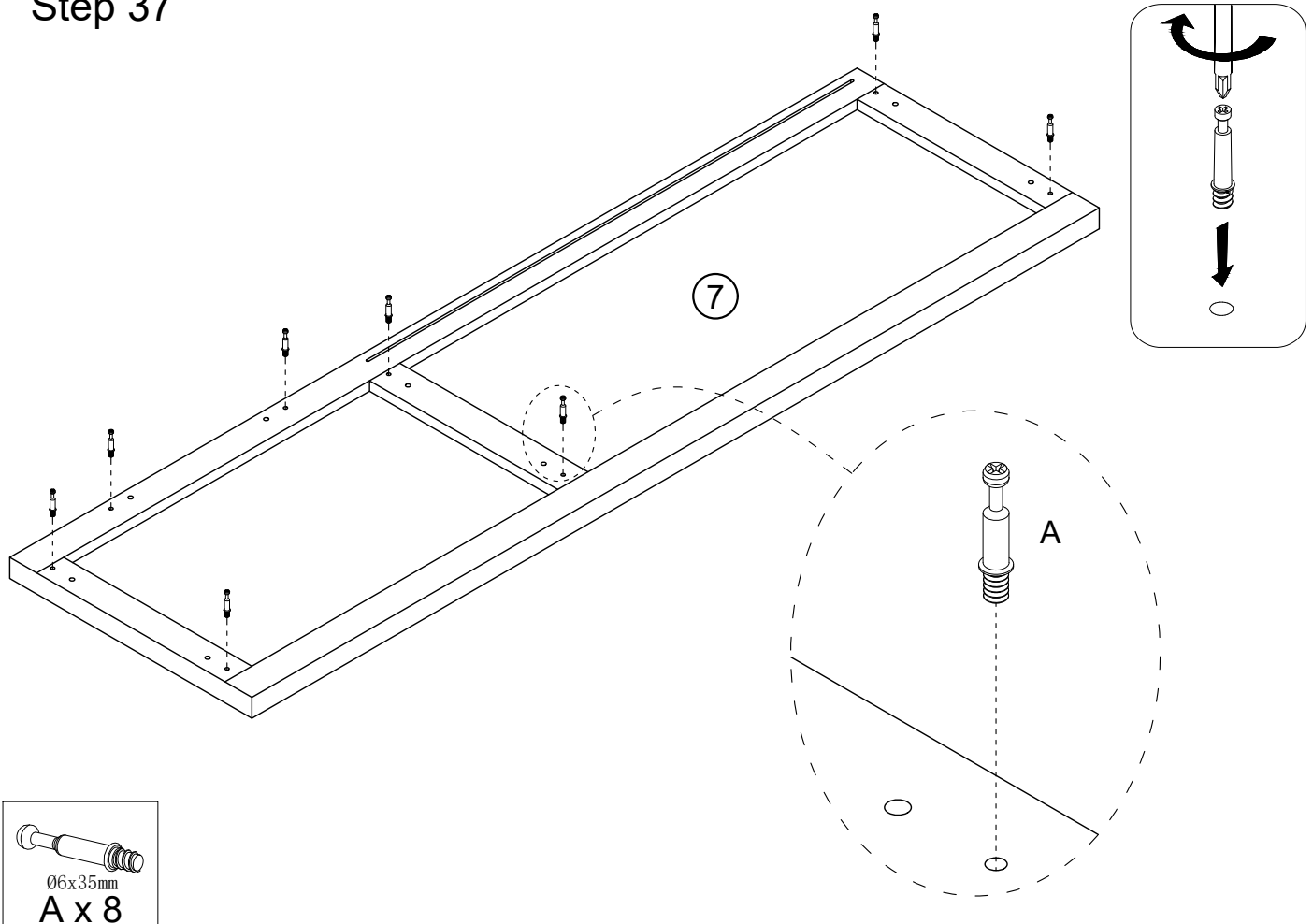

Step 38

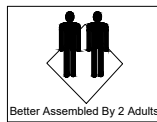
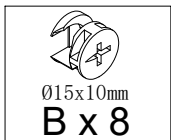
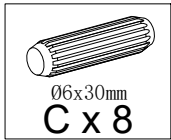
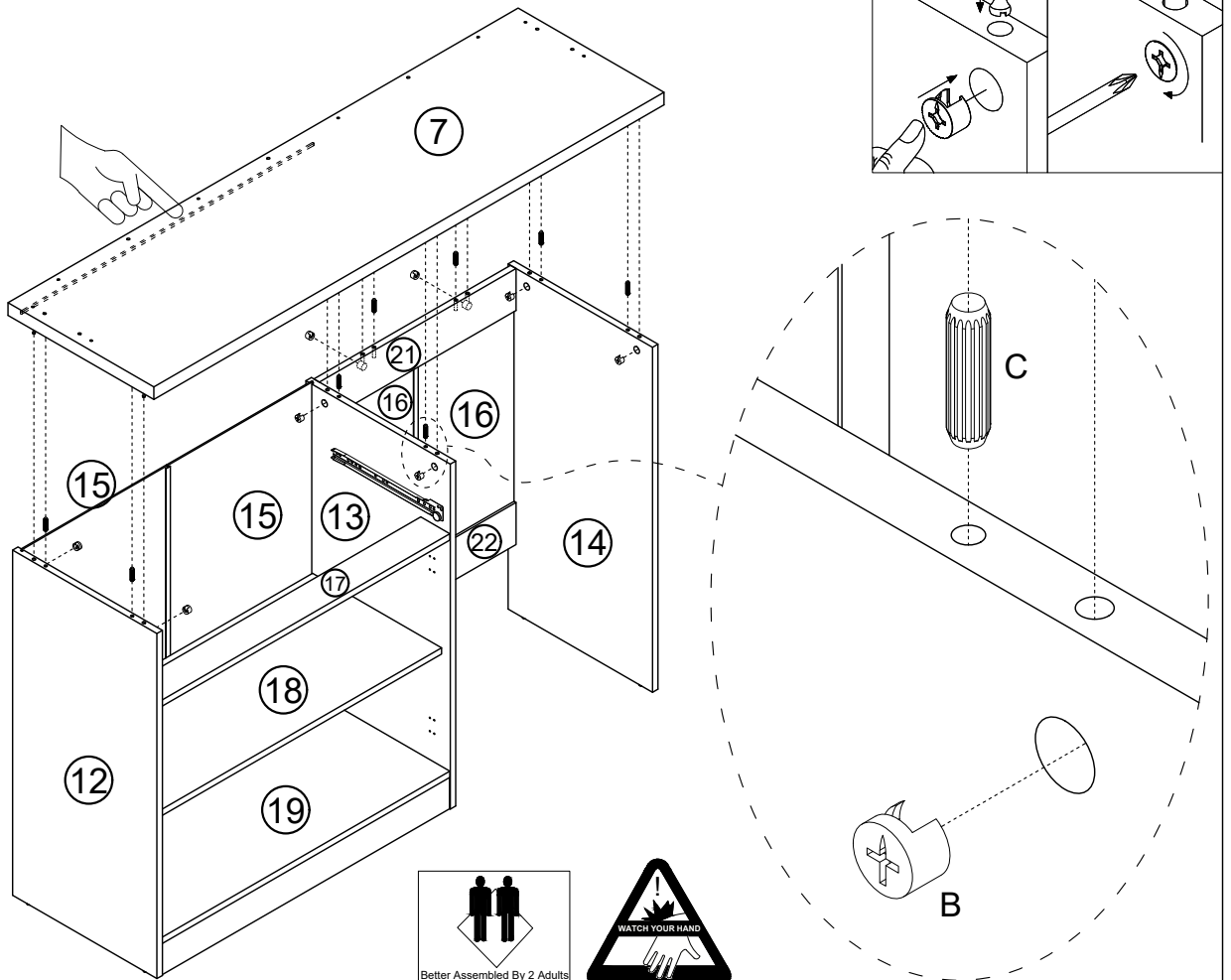

Step 39

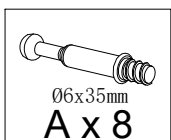
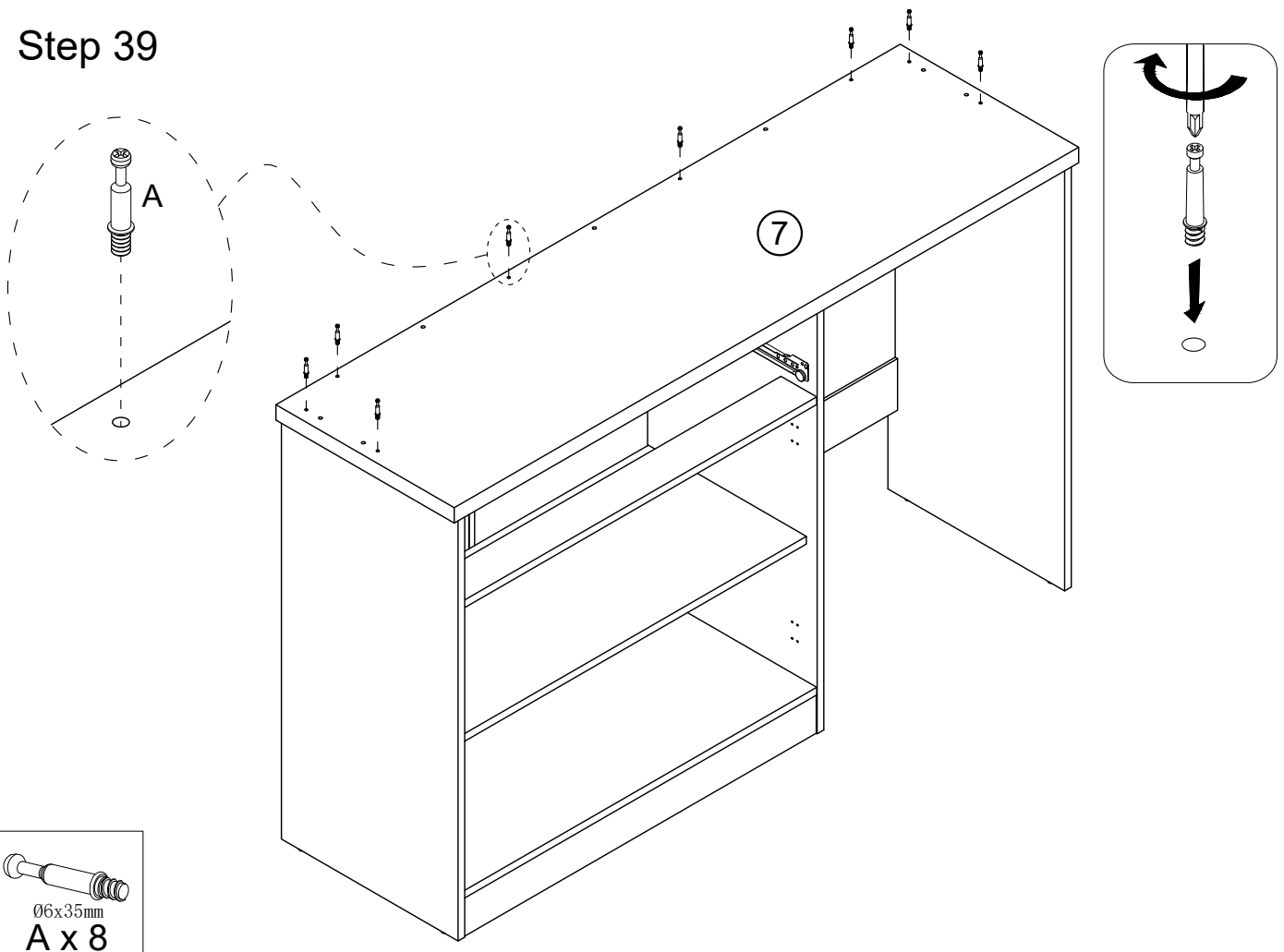

Step 40

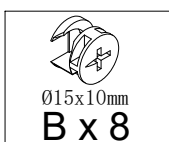
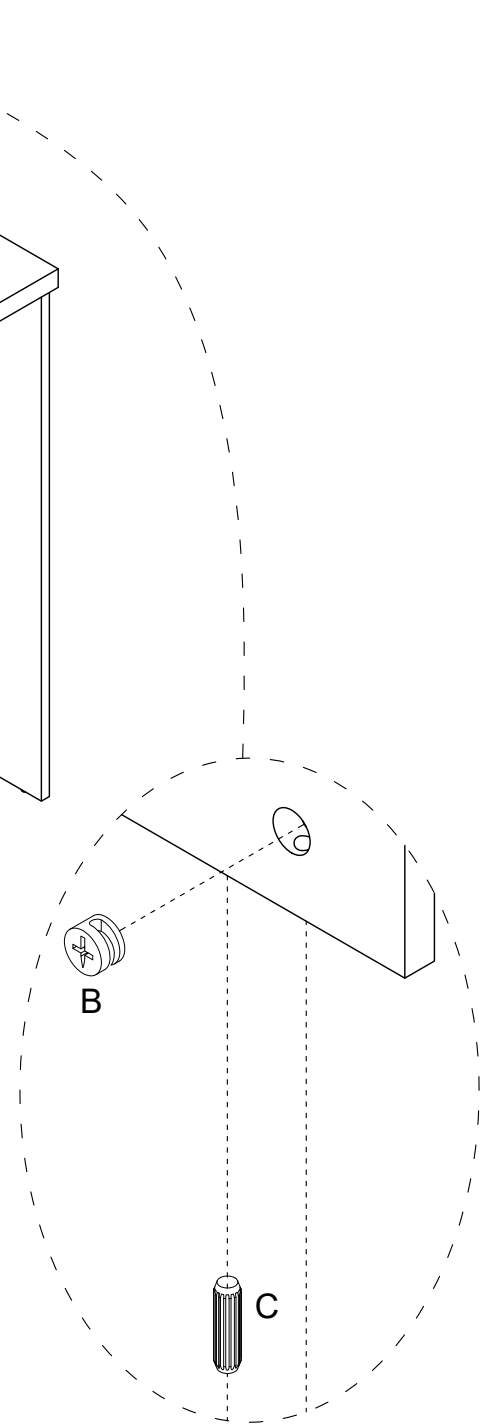
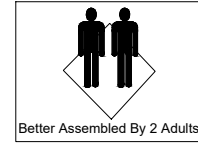
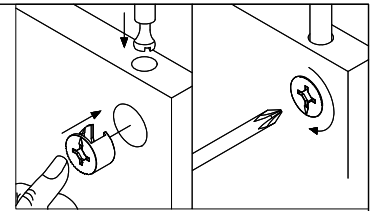
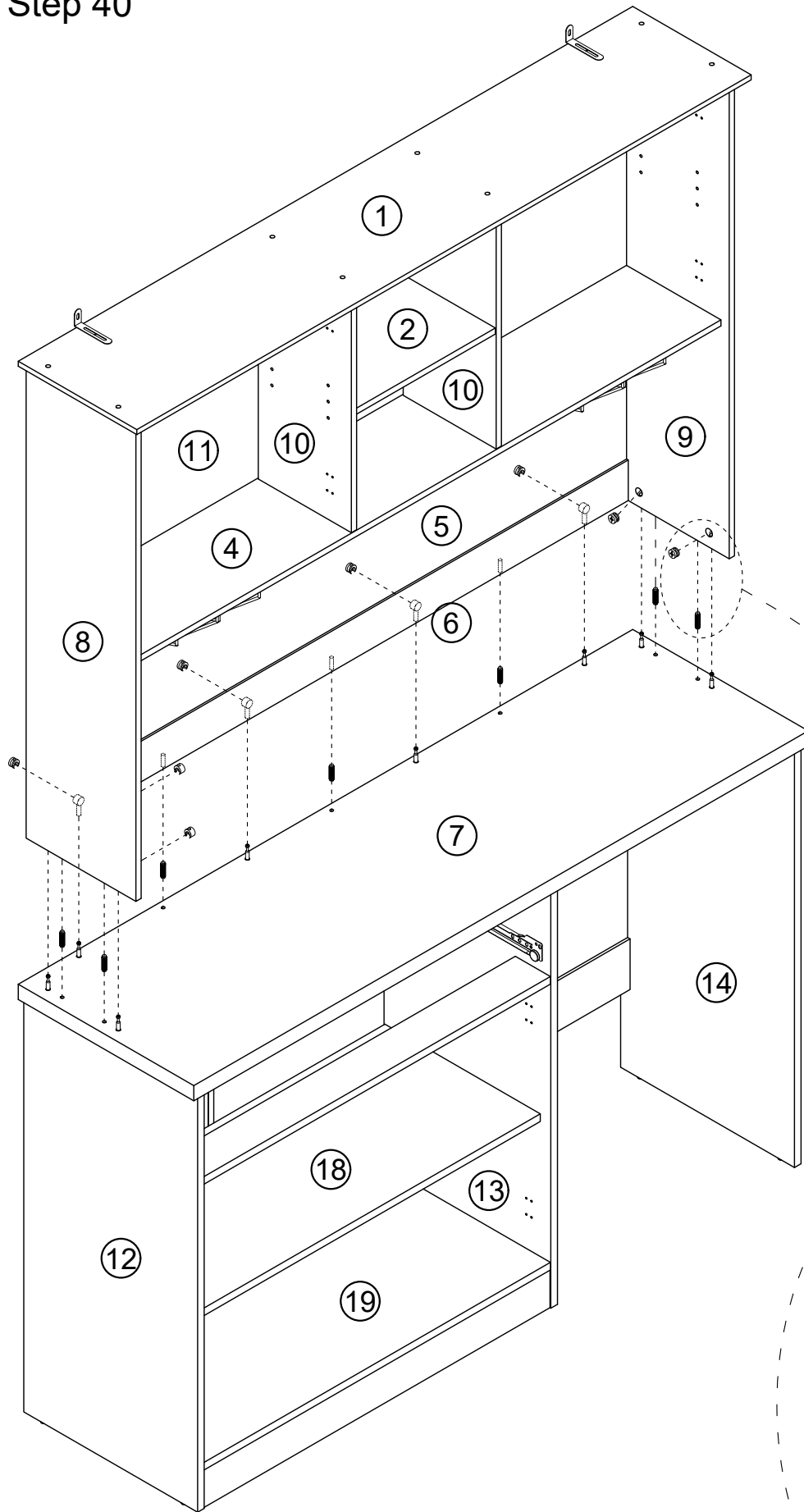

Step 41

DE: Drehpresse in das Loch einpassen Die Höhe kann nach Bedarf angepasst werden

UK: Rotary press into the hole You can adjust the height you want according to your needs

FR: Enfoncez la presse rotative dans le trou. Vous pouvez ajuster la hauteur souhaitée selon vos besoins

IT: Premere con un movimento rotatorio nel foro. È possibile regolare l'altezza desiderata in base alle proprie esigenze

ES: Presiona con un movimiento giratorio en el agujero. Puedes ajustar la altura que desees según tus necesidades.

NL: Draai de pers in het gat. Je kunt de hoogte naar behoefte aanpassen

SE: Rotary press in the hole. Du kan anpassa höjden efter dina behov.

PL: Obrótowa prasa do otworów. Możesz dostosować wysokość do swoich potrzeb.

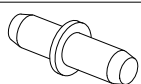
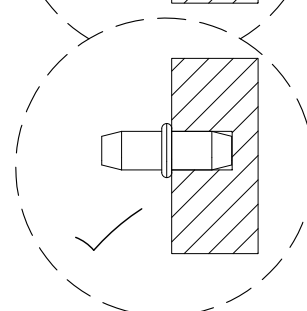
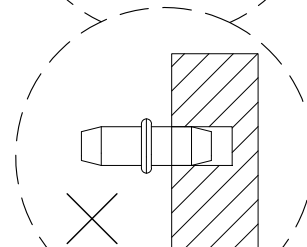
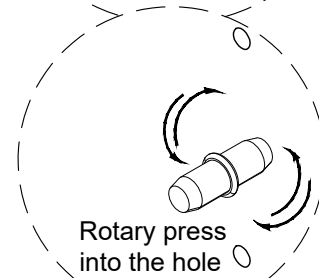
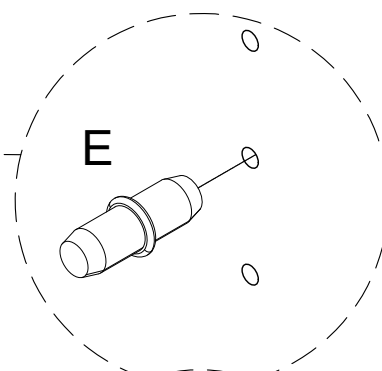
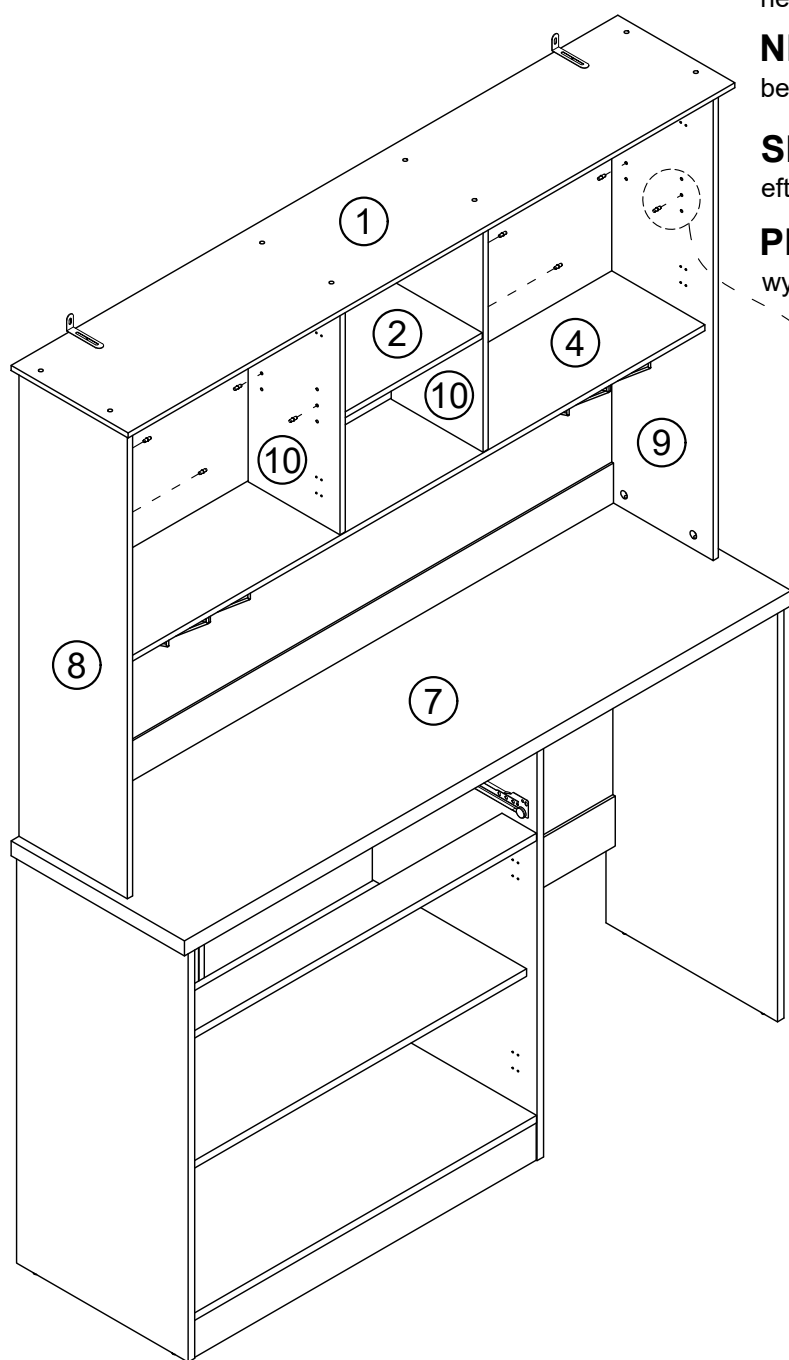

E x 8

Step 42

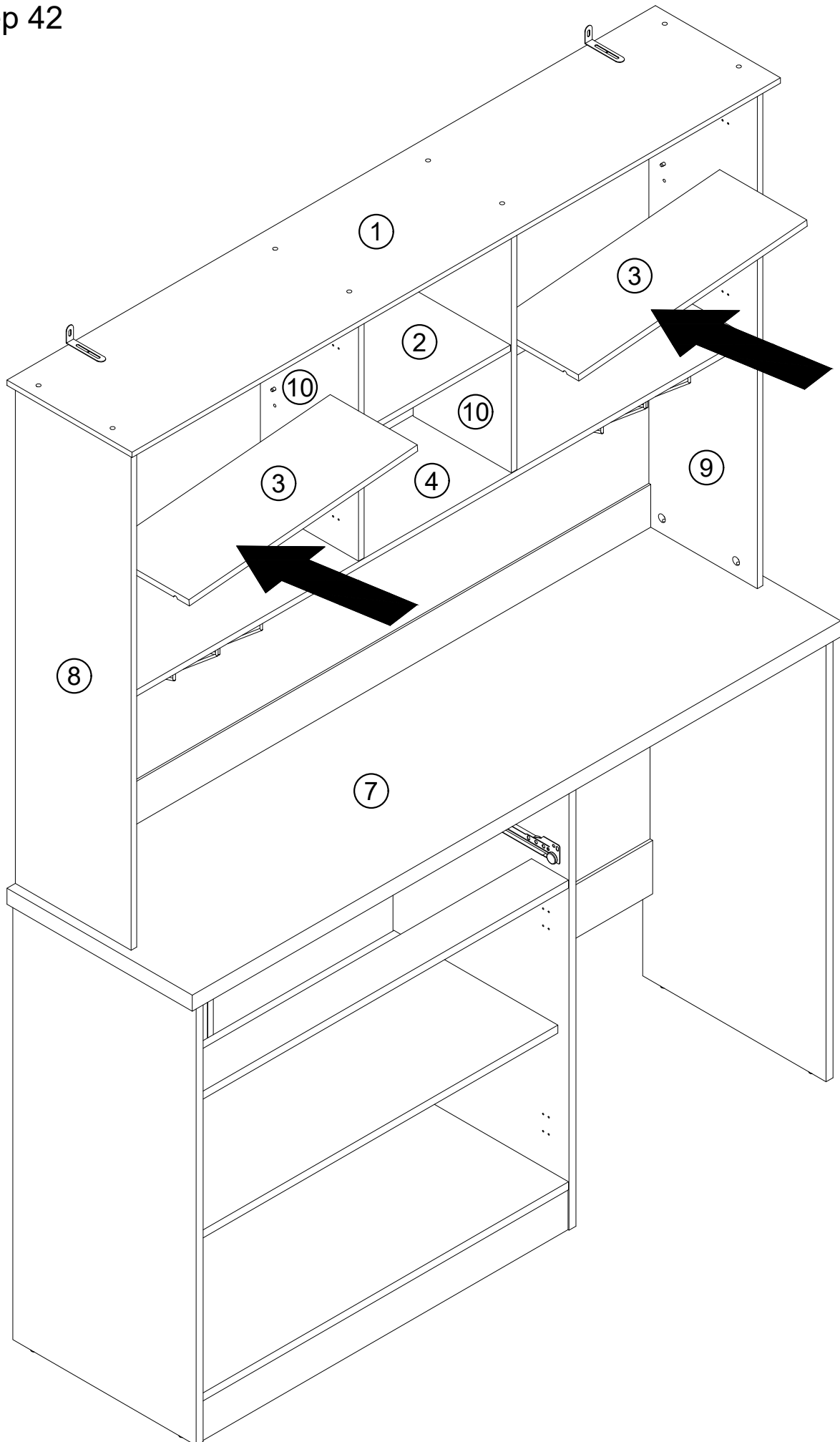

Step 43

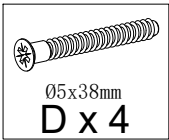
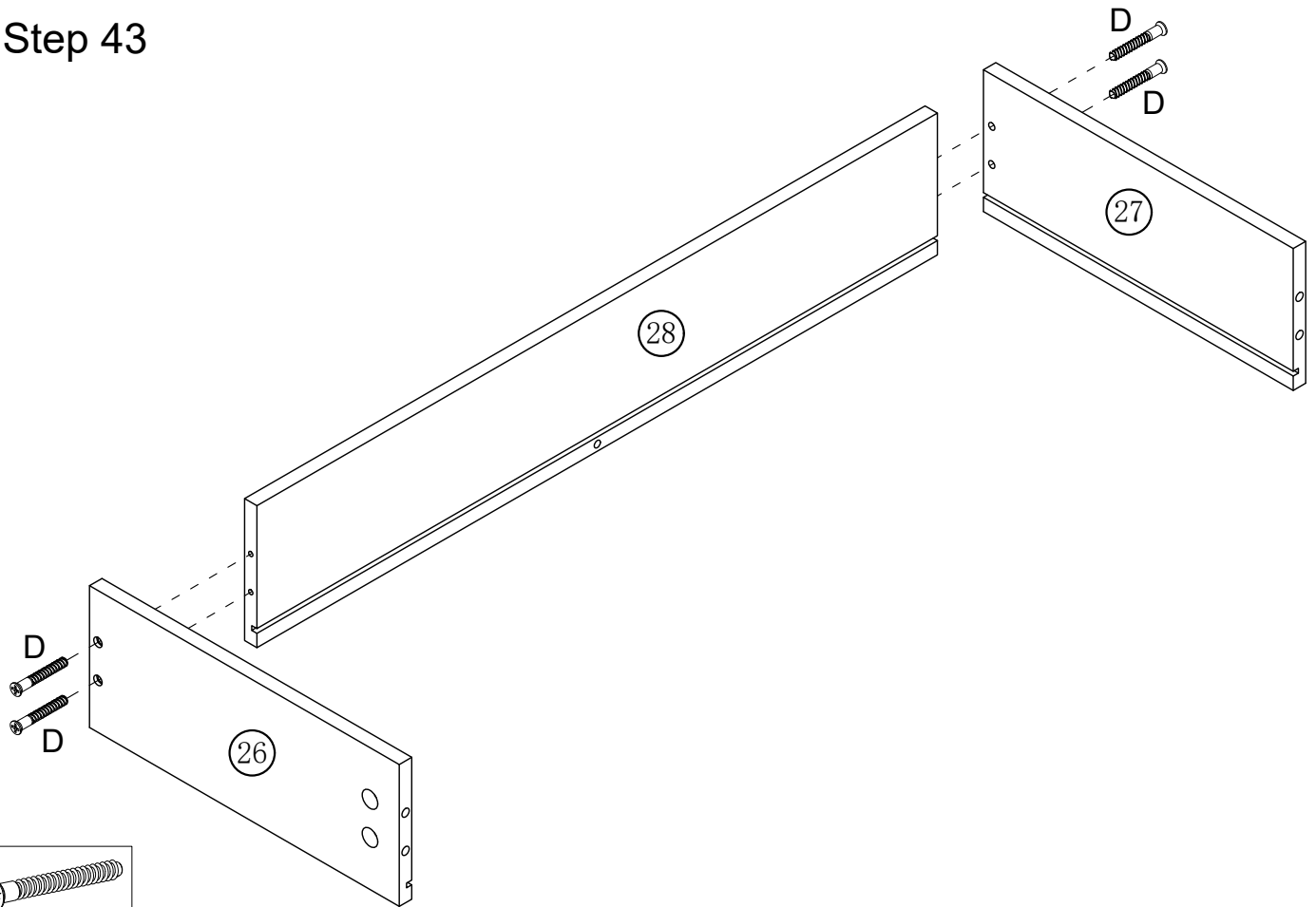

Step 44

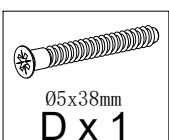
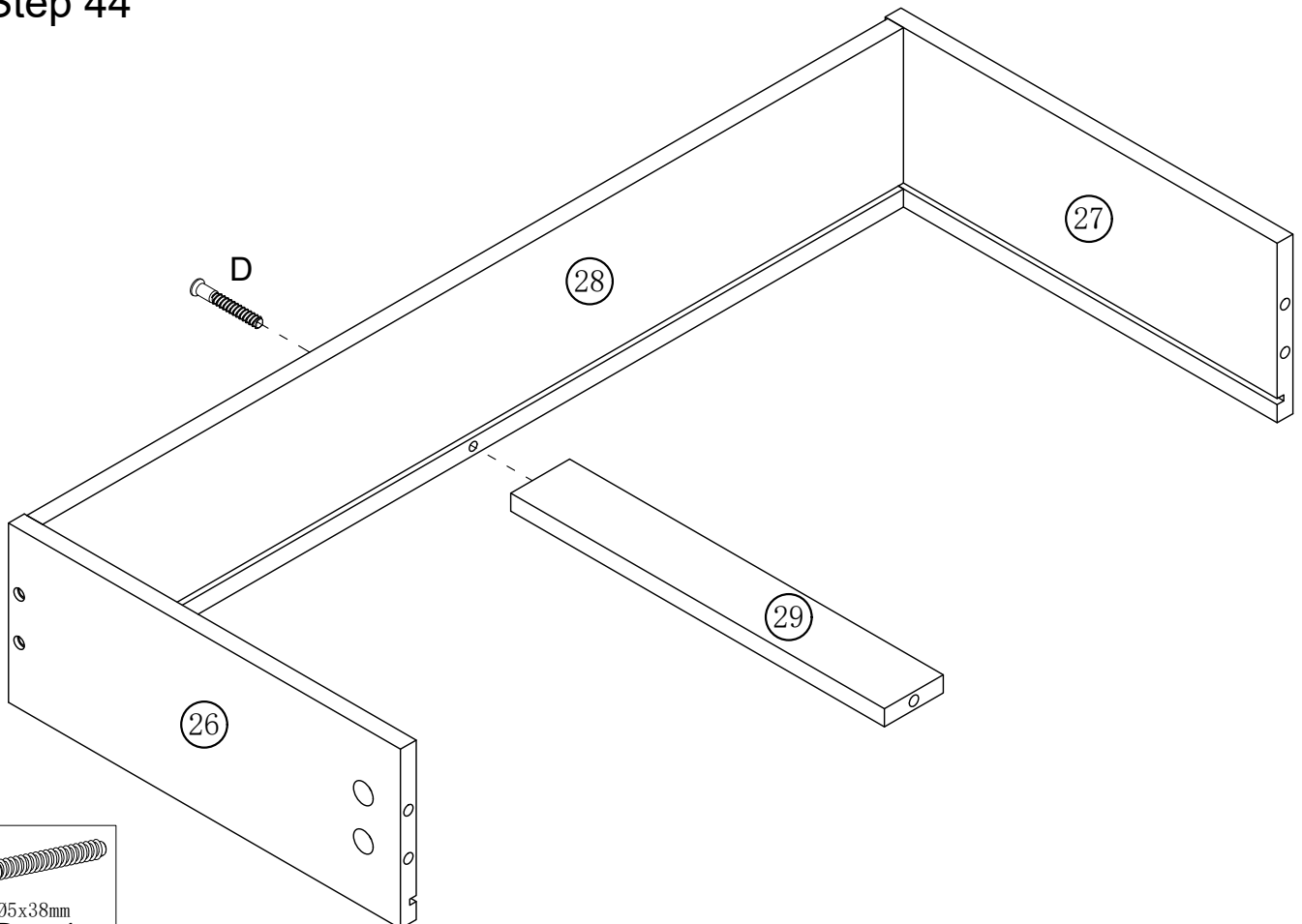

Step 45

DE: Die dünne Platte muss vollständig in die Nut eingeführt werden. Wenn das Einführen nicht reibungslos verläuft, können Sie versuchen, von vorne oder von hinten Druck auszuüben, um Anpassungen vorzunehmen, bis die dünne Platte vollständig in die Nut eingeführt ist.

UK: The thin plate needs to be fully inserted into the groove. If the insertion is not smooth, you can try pressing from the front or the back to make adjustments until the thin plate is fully inserted into the groove.

FR: La plaque mince doit être entièrement insérée dans la rainure. Si l'insertion ne se fait pas facilement, vous pouvez essayer d'appuyer à l'avant ou à l'arrière pour ajuster la plaque jusqu'à ce qu'elle soit entièrement insérée dans la rainure.

IT: La piastra sottile deve essere inserita completamente nella scanalatura. Se l'inserimento non avviene in modo fluido, è possibile provare a premere dalla parte anteriore o posteriore per effettuare le regolazioni necessarie fino a quando la piastra sottile non è inserita completamente nella scanalatura.

ES: La placa delgada debe insertarse completamente en la ranura. Si la inserción no es fluida, puede intentar presionar desde la parte delantera o trasera para realizar ajustes hasta que la placa delgada se inserte completamente en la ranura.

NL: De dunne plaat moet volledig in de groef worden gestoken. Als het insteken niet soepel verloopt, kunt u proberen vanaf de voorkant of de achterkant druk uit te oefenen om aanpassingen te maken totdat de dunne plaat volledig in de groef is gestoken.

SE: Den tunna plattan måste sättas in helt i spåret. Om den inte går in smidigt kan du försöka trycka från framsidan eller baksidan för att justera tills den tunna plattan är helt insatt i spåret.

PL: Cienką płytkę należy całkowicie wsunąć w rowek. Jeśli wsuwanie nie przebiega płynnie, można spróbować docisnąć ją od przodu lub od tyłu, dopasowując ją tak, aby całkowicie wsunęła się w rowek.

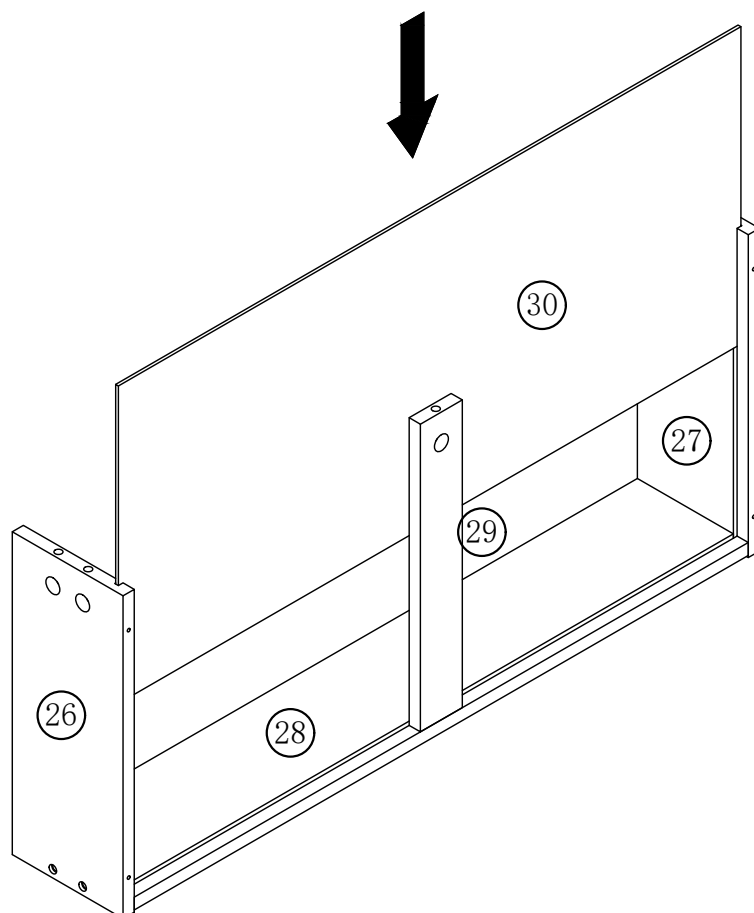

Step 46

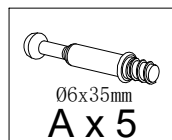
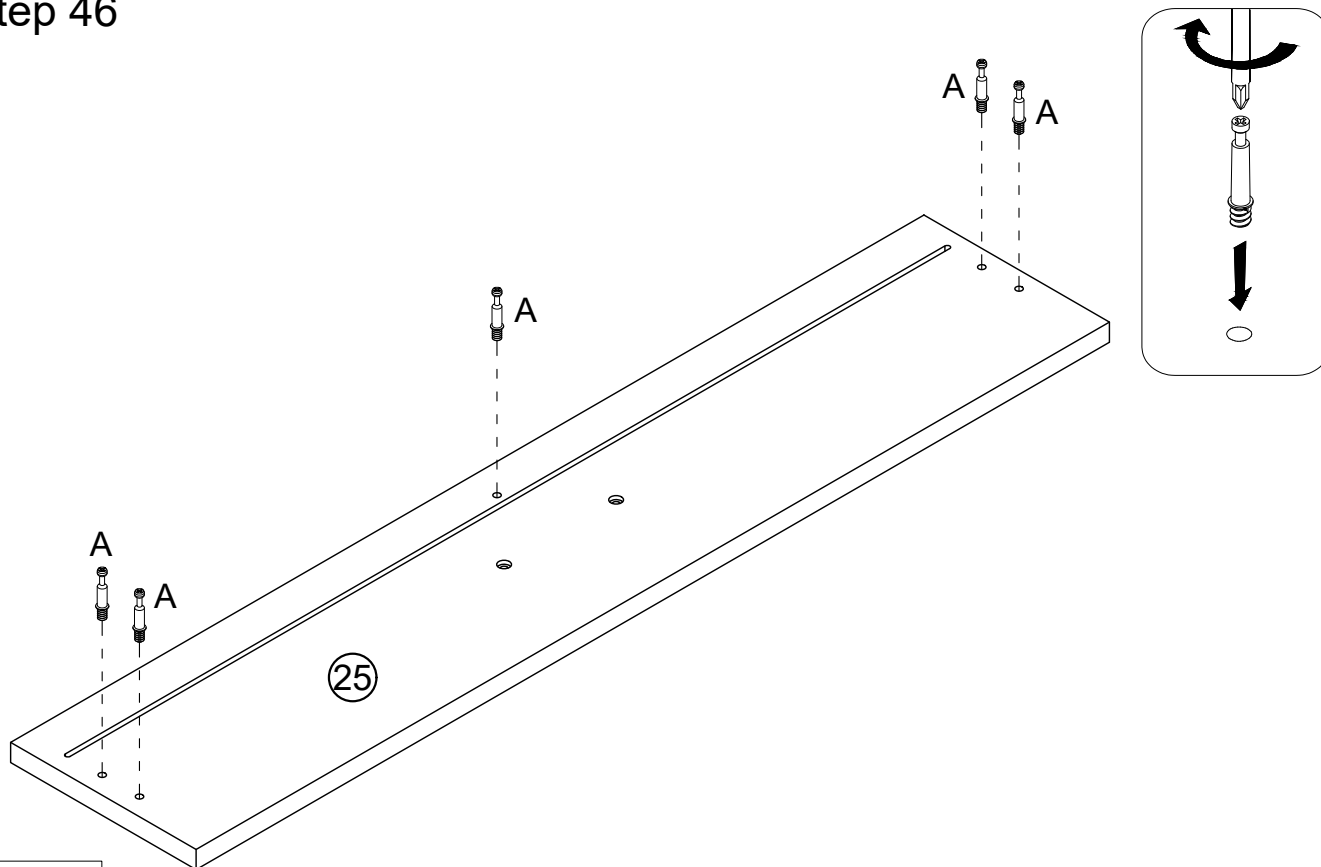

Step 47

DE: Decken Sie das sichtbare Loch mit einer Kappe ab.

UK: Cover the visible hole with a cap

FR: Couvrez le trou visible avec un capuchon.

IT: Copri il foro visibile con un tappo.

ES: Cubra el orificio visible con una tapa.

NL: Bedek het zichtbare gat met een dopje.

SE: Täck det synliga hålet med en lock.

PL: Zakryj widoczną dziurę nasadką.

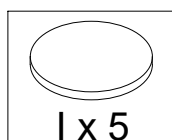
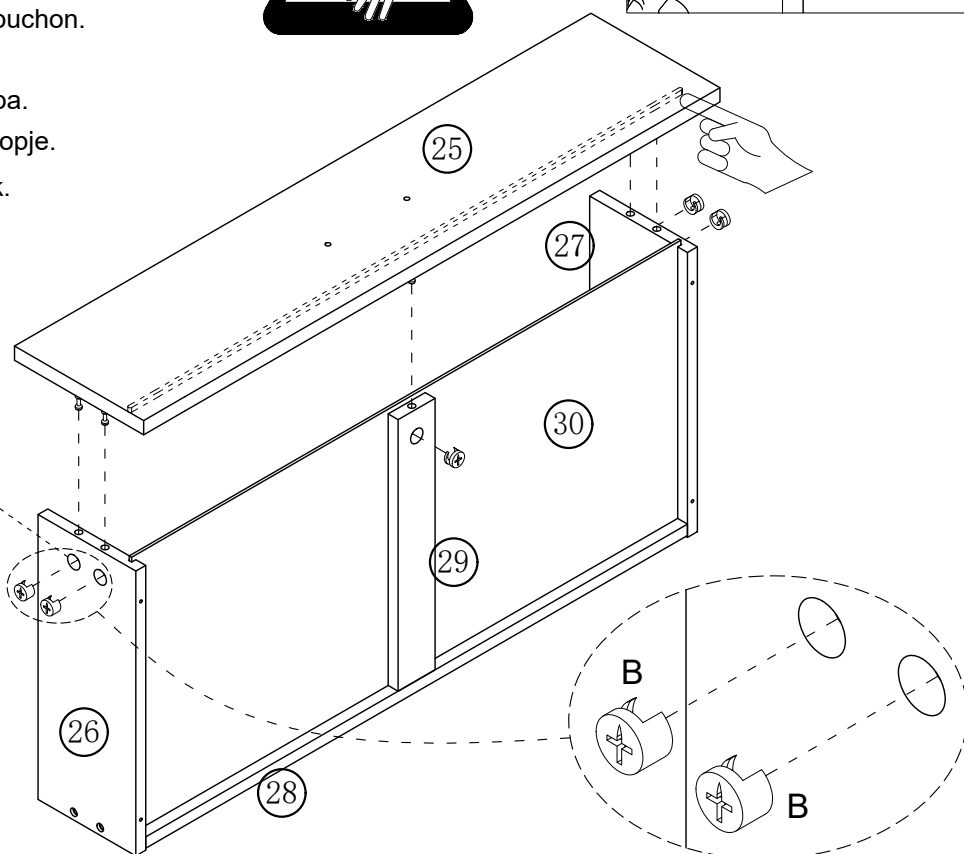
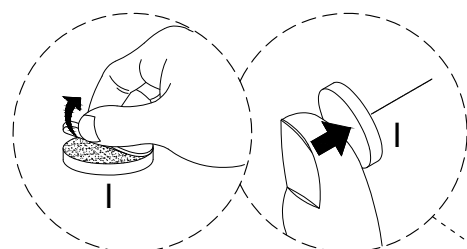
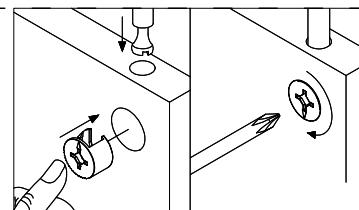

Step 48

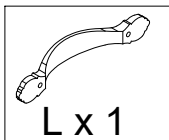
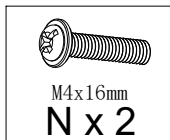
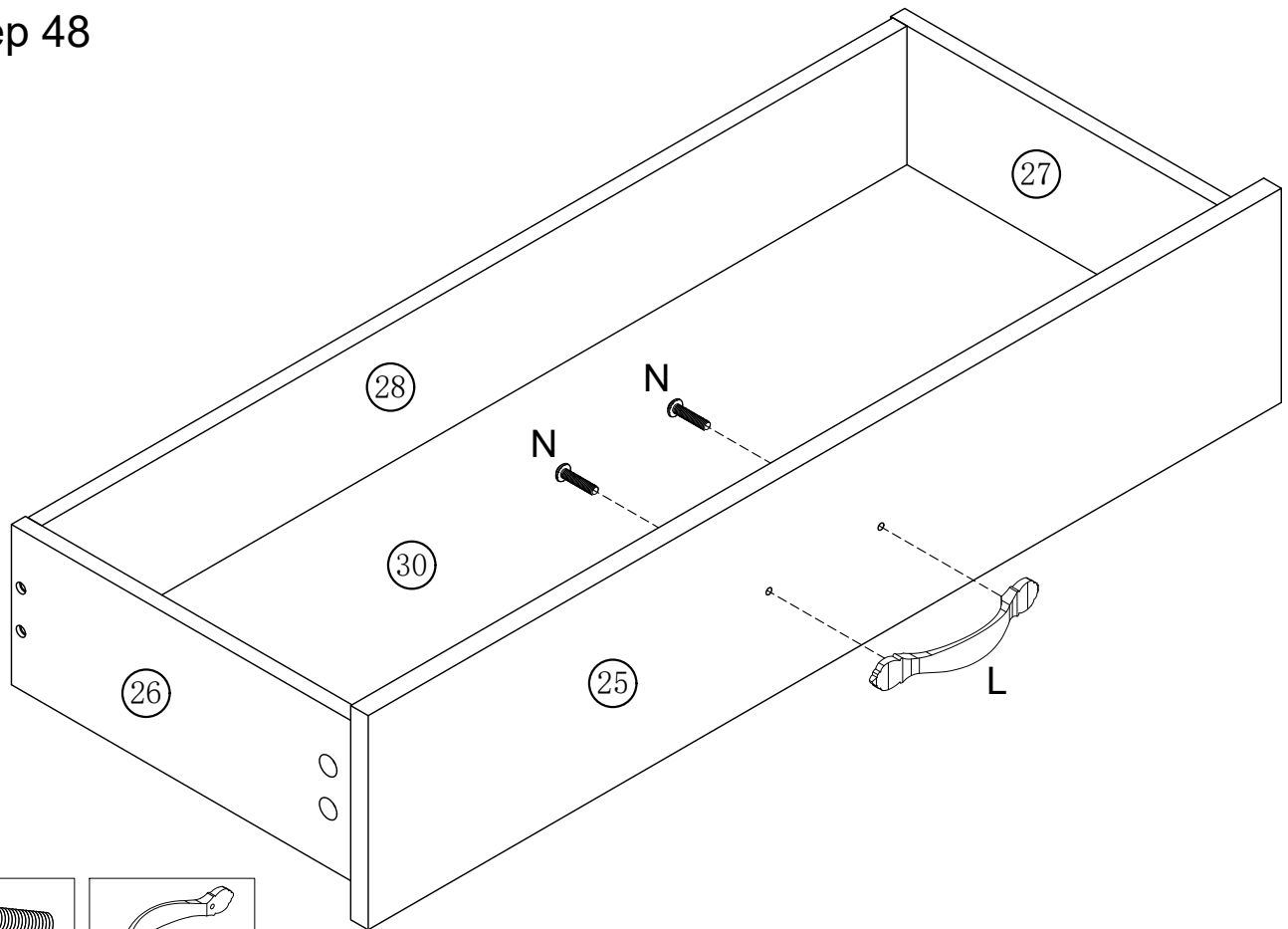

Step 49

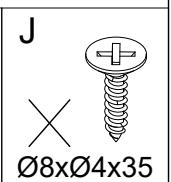
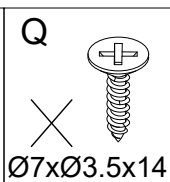
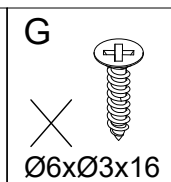
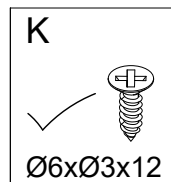
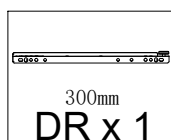
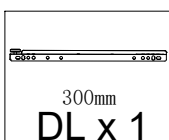
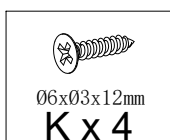
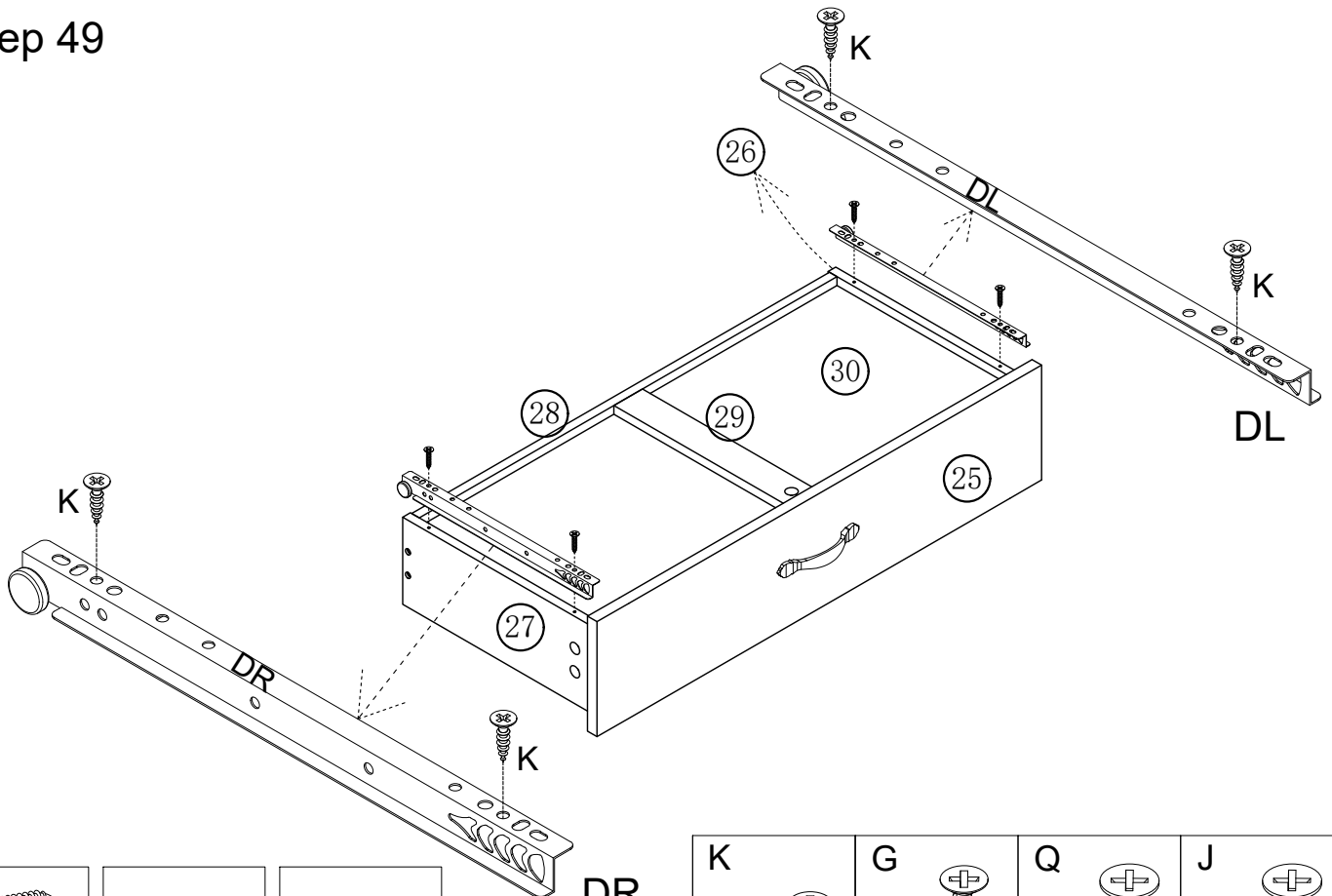

Step 50

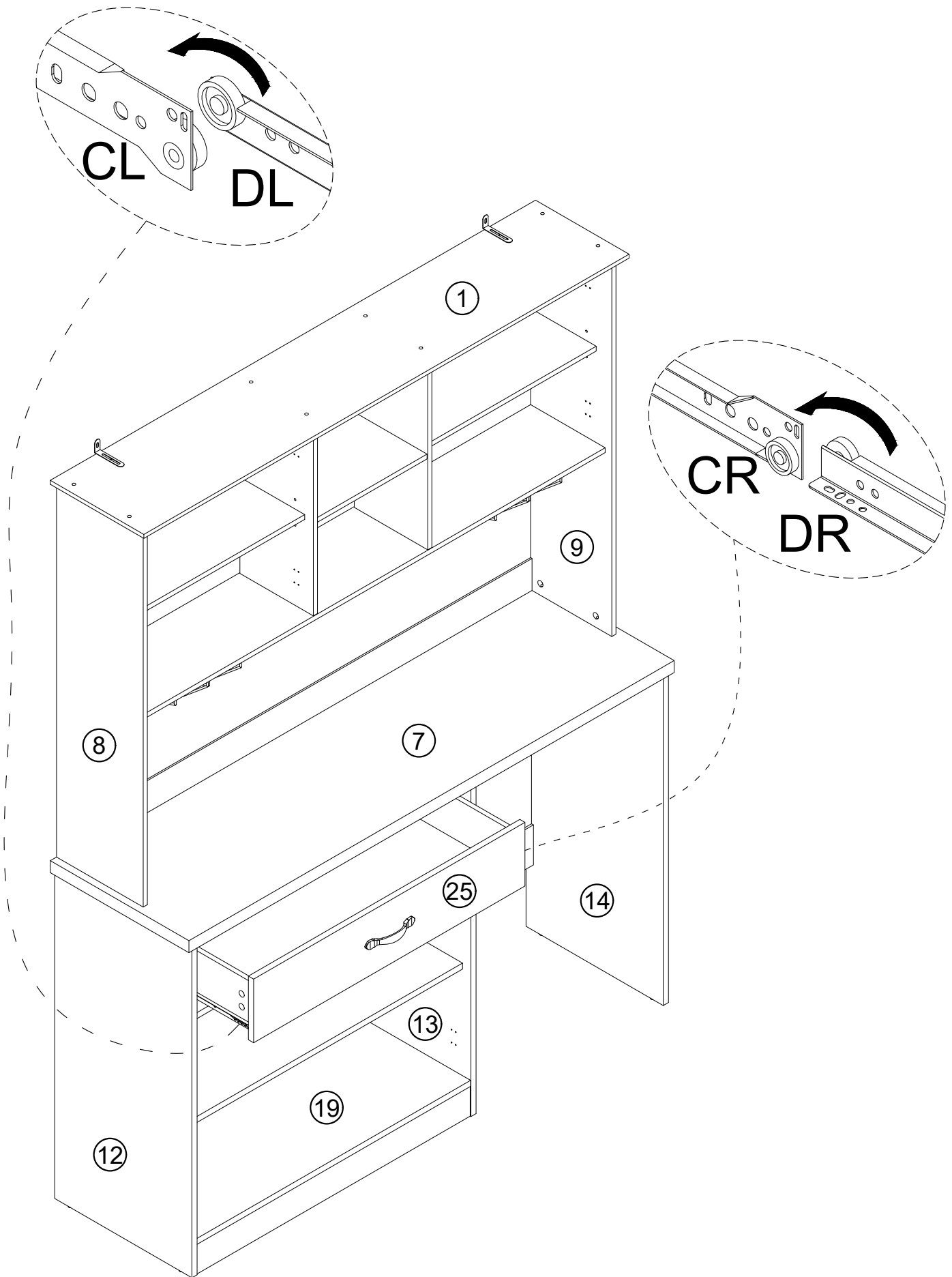

Step 51

K ✗ Ø6xØ3x12	G ✗ Ø6xØ3x16	Q ✓ Ø7xØ3.5x14	J ✗ Ø8xØ4x35
---------------------------	---------------------------	-----------------------------	---------------------------

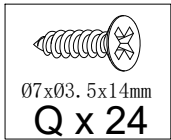
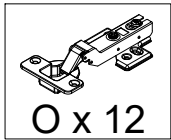
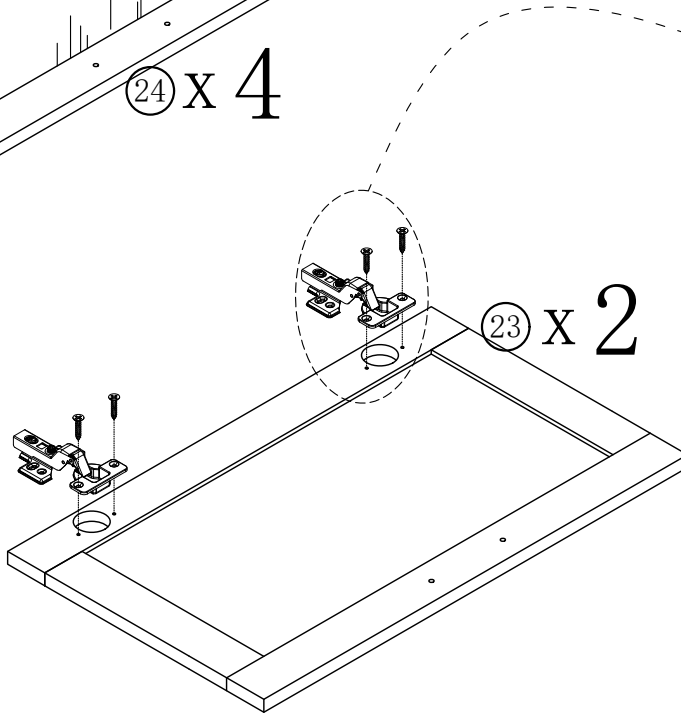
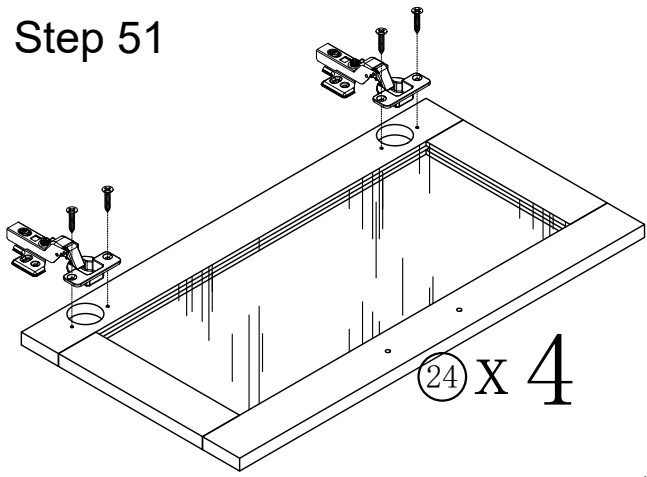

Step 52

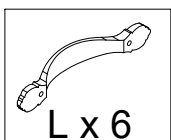
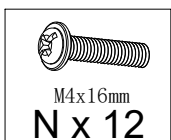
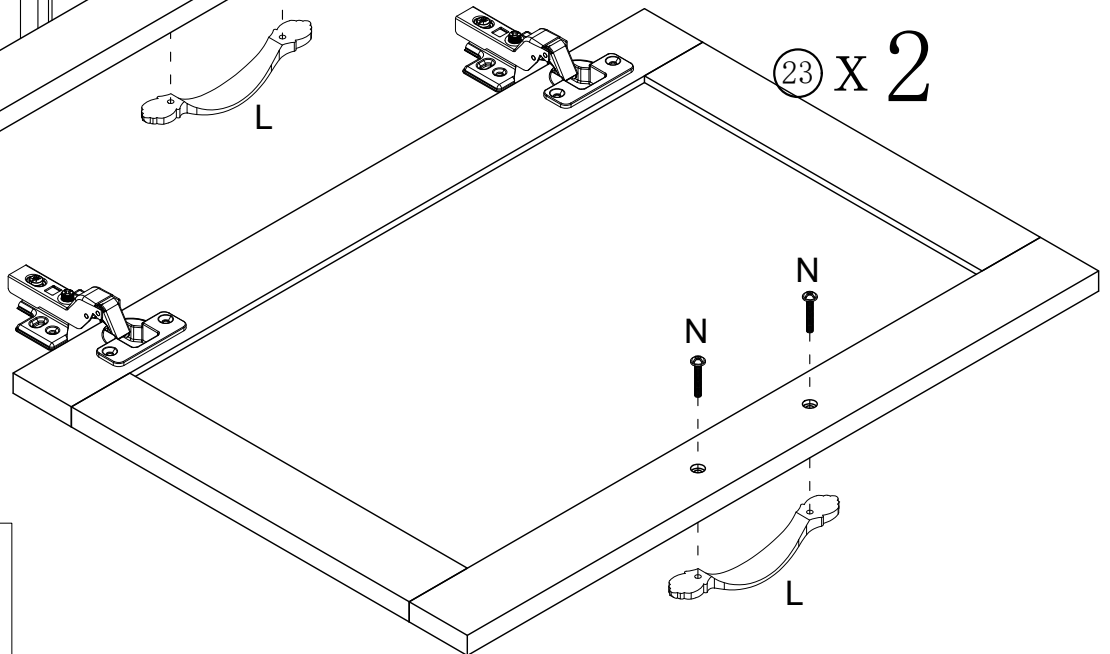
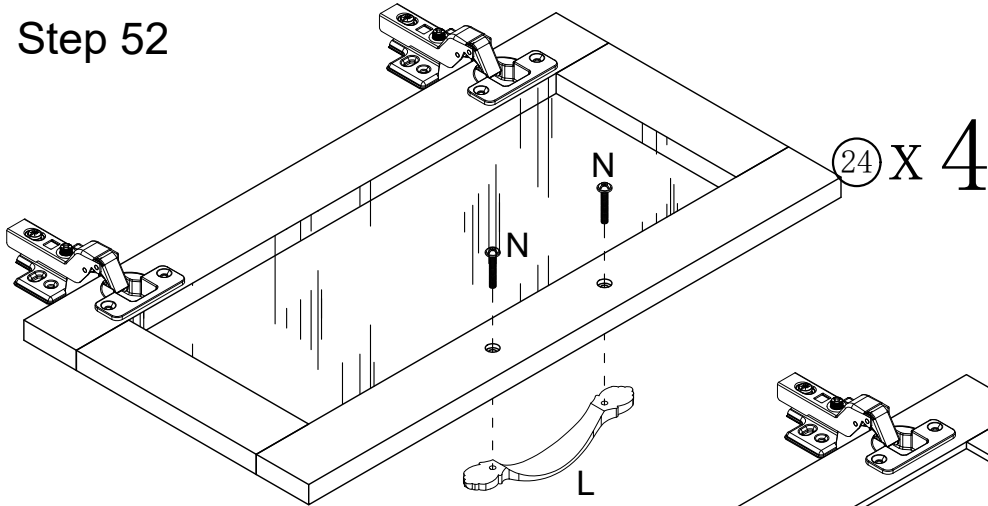

Step 53

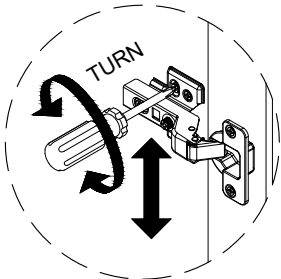

Loosen this screw and push up/down for a slight up-down adjustment of the door.

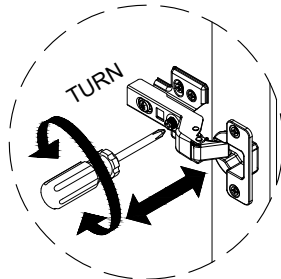

Loosen this screw for a slight left-right adjustment of the door.

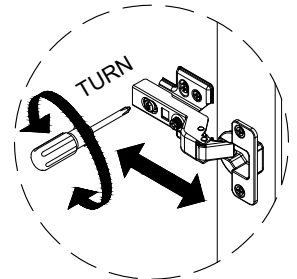

Loosen this screw and push forward/backward for a slight front-back adjustment of the door.

K	G	Q	J
✗	✗	✓	✗
Ø6xØ3x12	Ø6xØ3x16	Ø7xØ3.5x14	Ø8xØ4x35

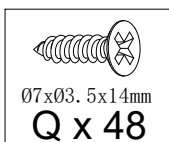
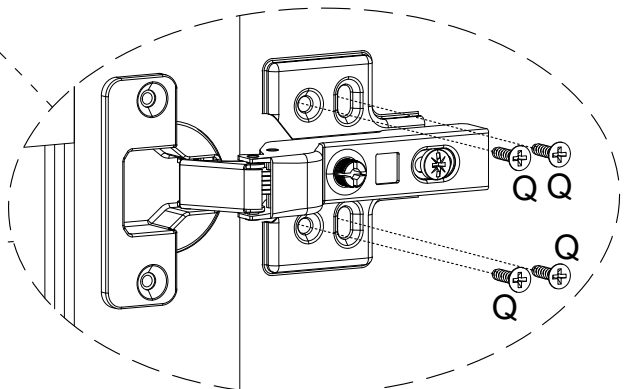
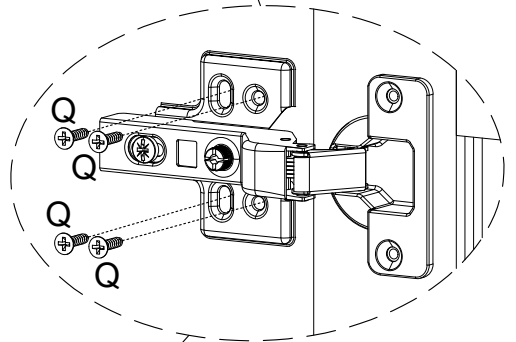
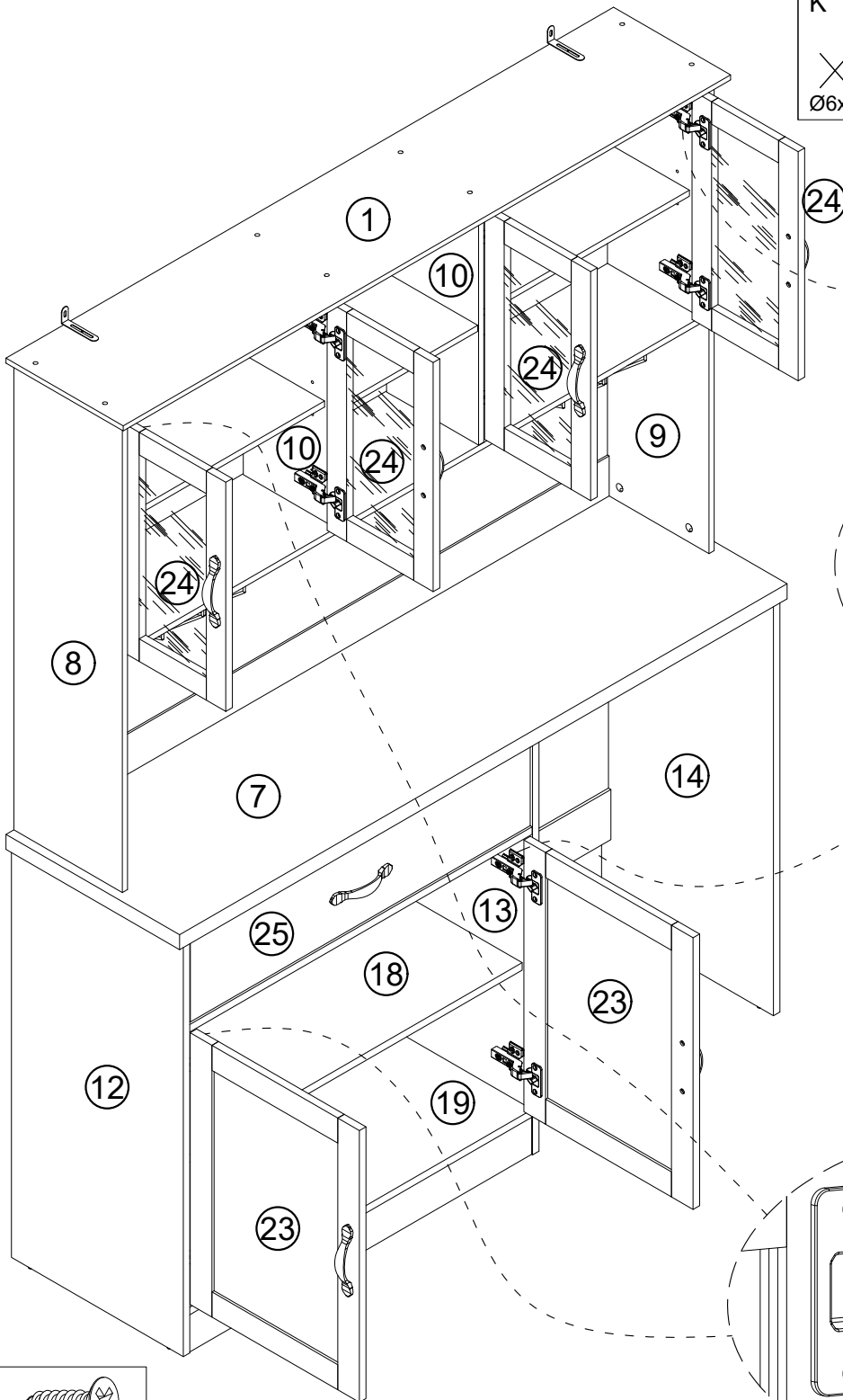

Step 54

DE: Decken Sie das sichtbare Loch mit einer Kappe ab.

UK: Cover the visible hole with a cap

FR: Couvrez le trou visible avec un capuchon.

IT: Copri il foro visibile con un tappo.

ES: Cubra el orificio visible con una tapa.

NL: Bedek het zichtbare gat met een dopje.

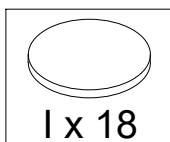
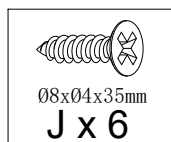
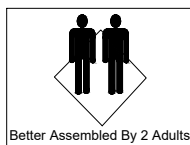
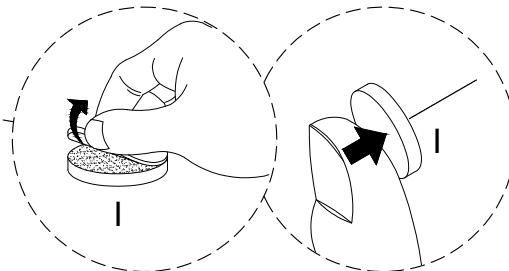
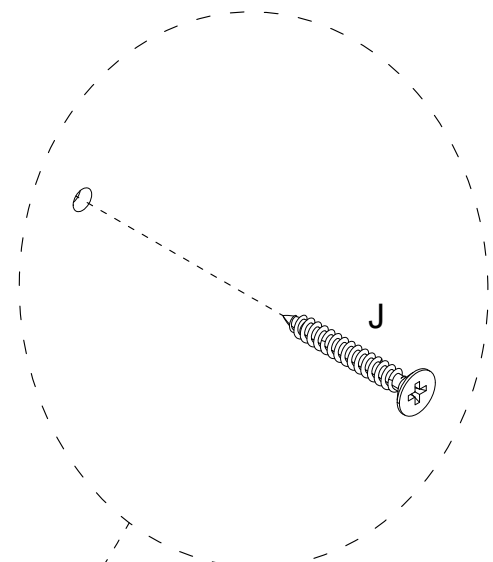
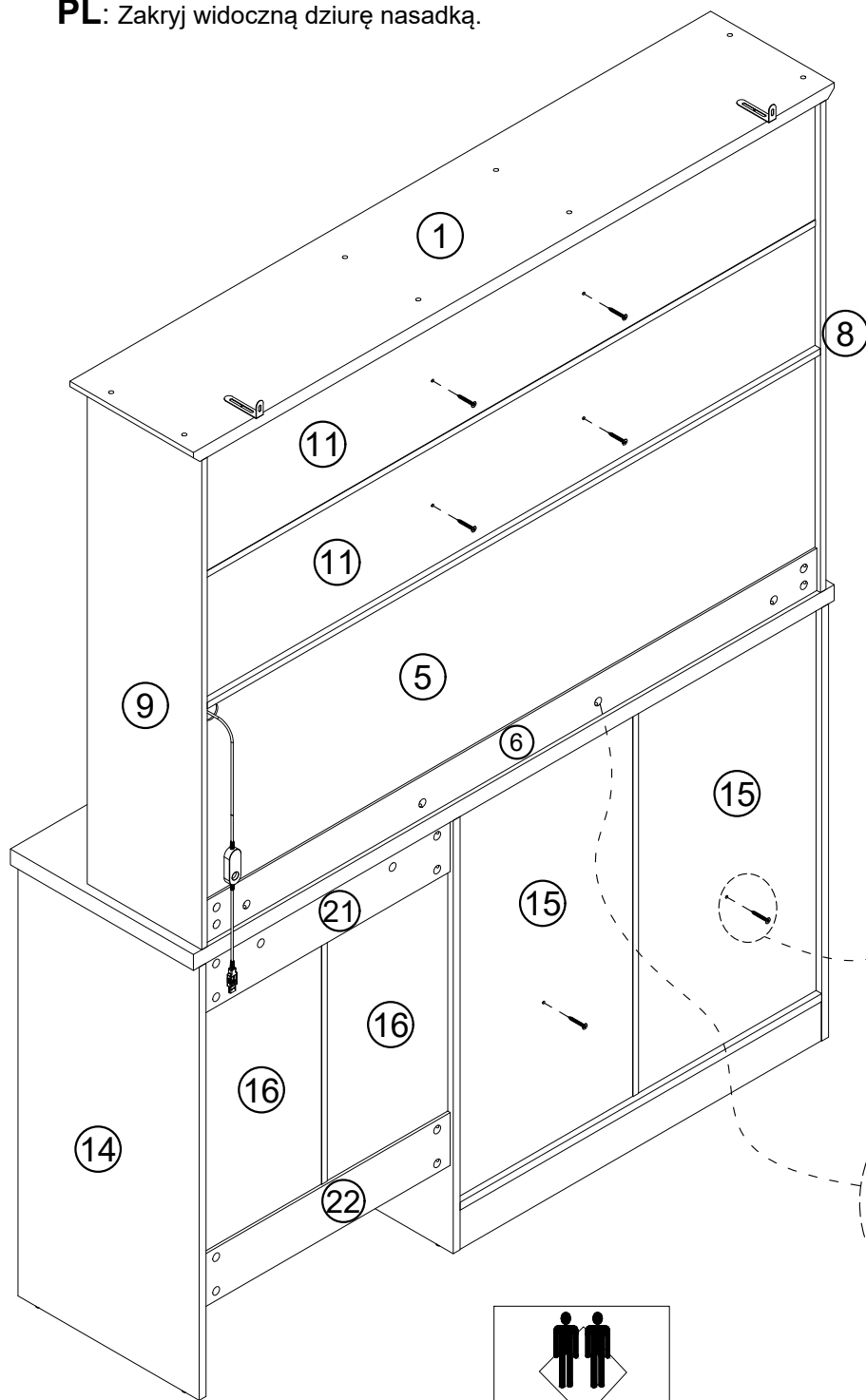
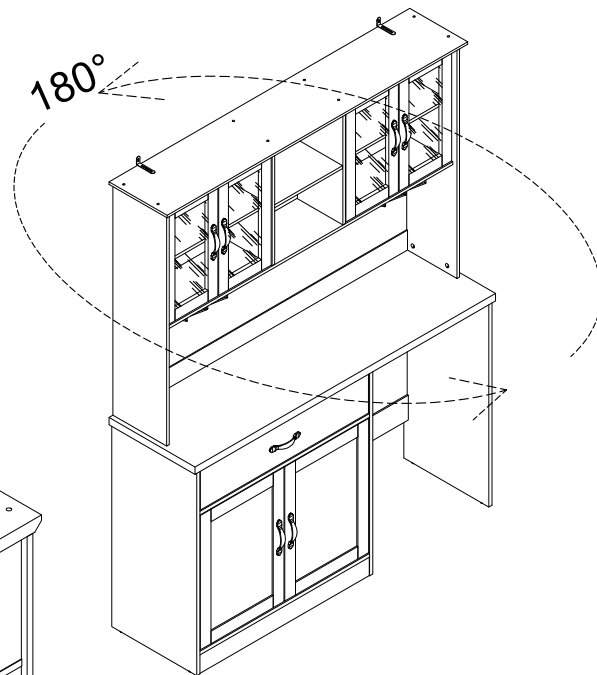

SE: Täck det synliga hålet med en lock.

PL: Zakryj widoczną dziurę nasadką.

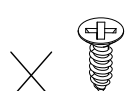
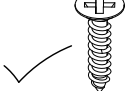

<p>K</p> <p>Ø6xØ3x12</p>	<p>G</p> <p>Ø6xØ3x16</p>	<p>Q</p> <p>Ø7xØ3.5x14</p>	<p>J</p> <p>Ø8xØ4x35</p>
---------------------------------	---------------------------------	-----------------------------------	---------------------------------

Step 55

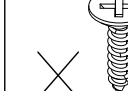
<p>K</p>  <p>Ø6xØ3x12</p>	<p>G</p>  <p>Ø6xØ3x16</p>	<p>Q</p>  <p>Ø7xØ3.5x14</p>	<p>J</p>  <p>Ø8xØ4x35</p>
--------------------------------------------------------------------------------------------------------------------	---------------------------------------------------------------------------------------------------------------------	-----------------------------------------------------------------------------------------------------------------------	---------------------------------------------------------------------------------------------------------------------

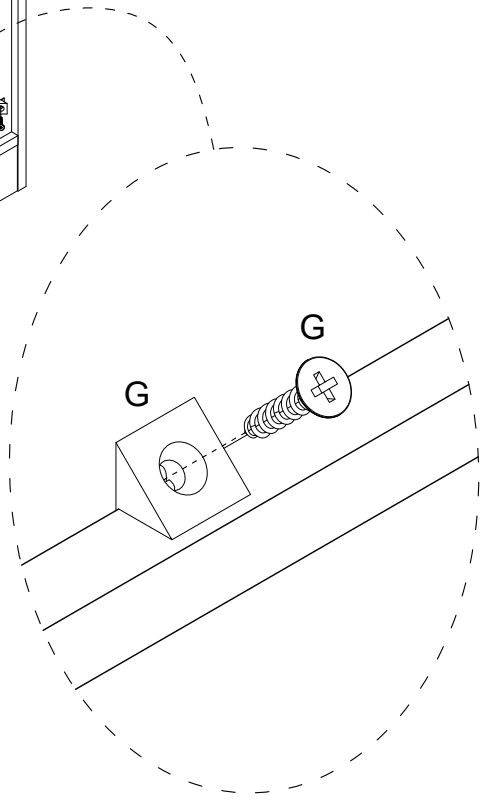
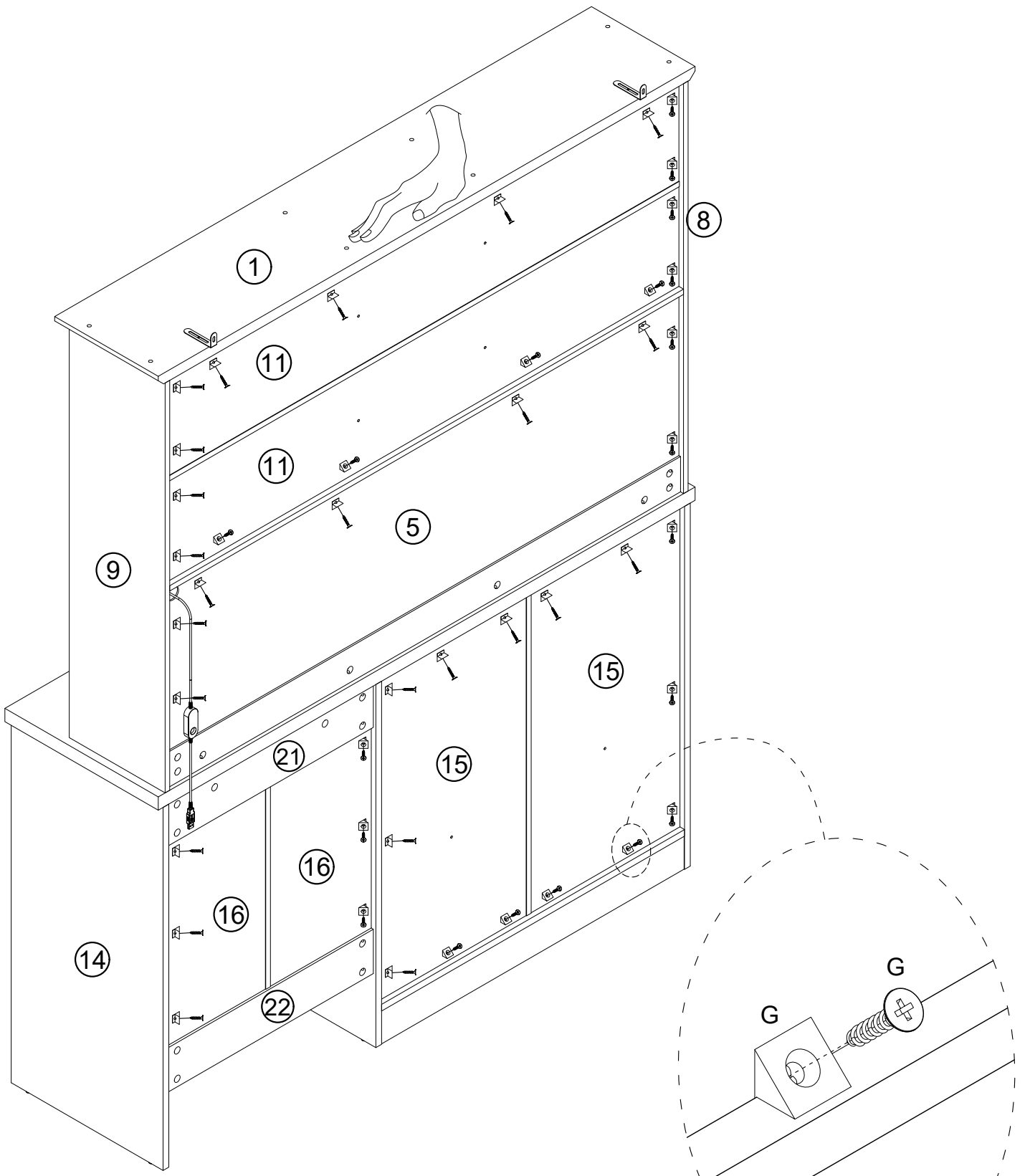
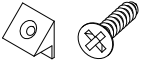

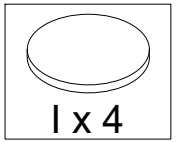
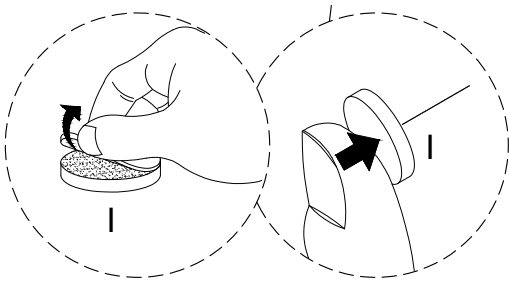
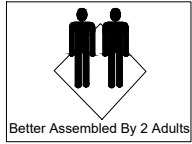
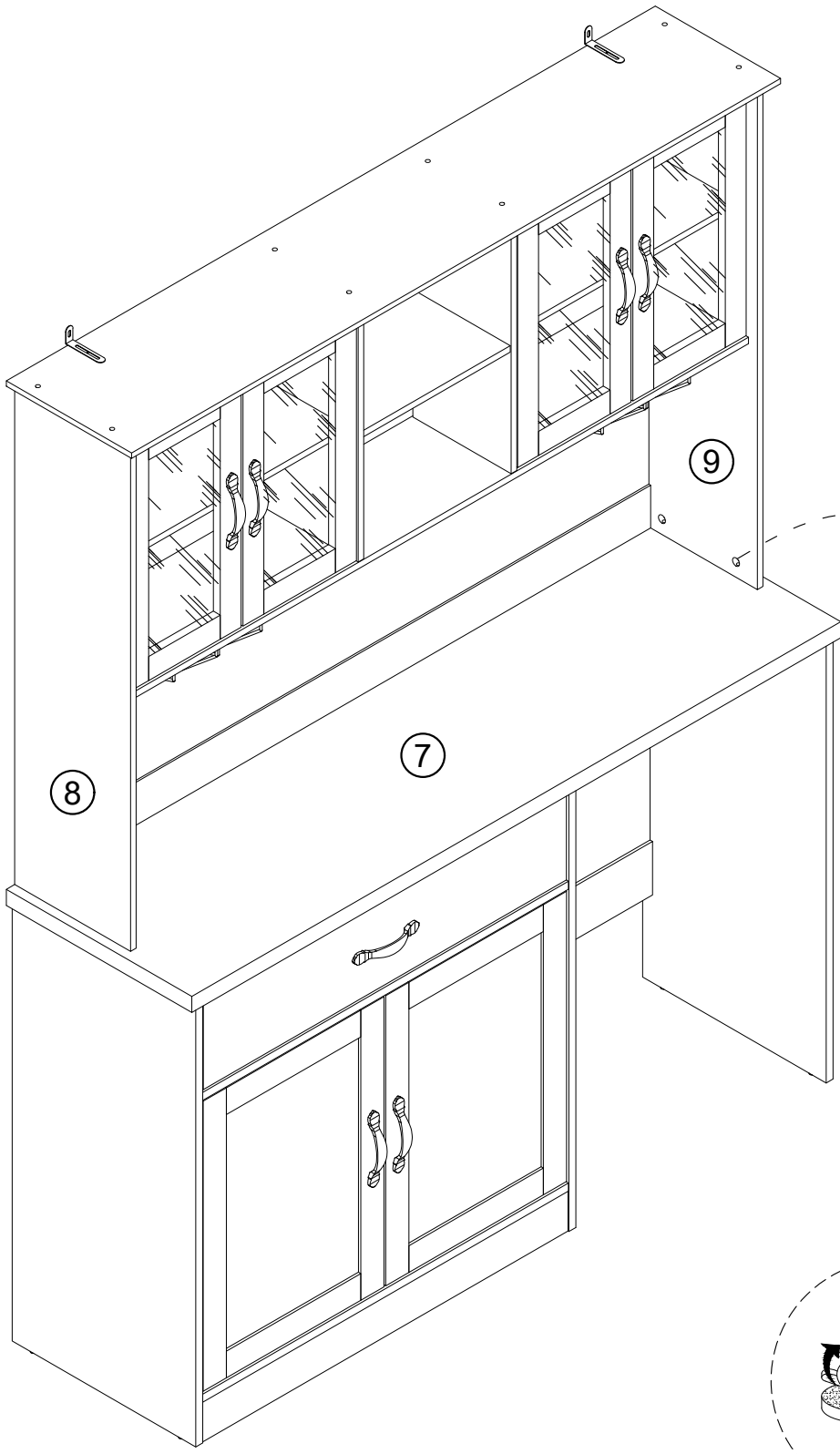
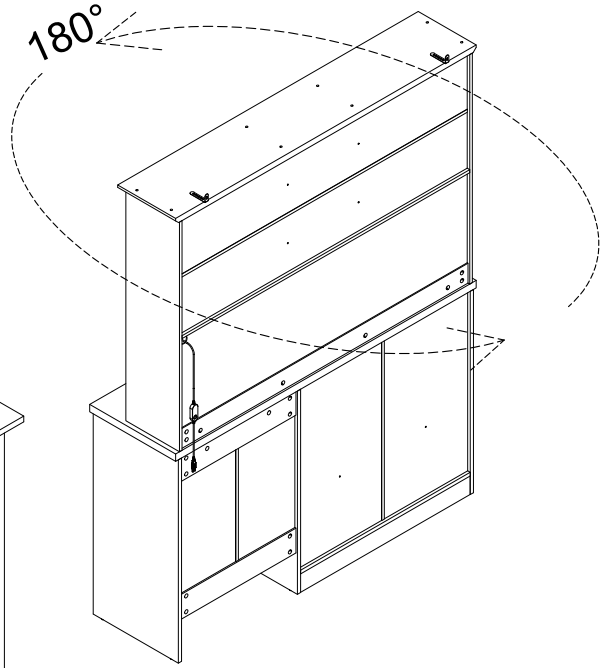

Ø6xØ3x16mm
G x 44

Step 56

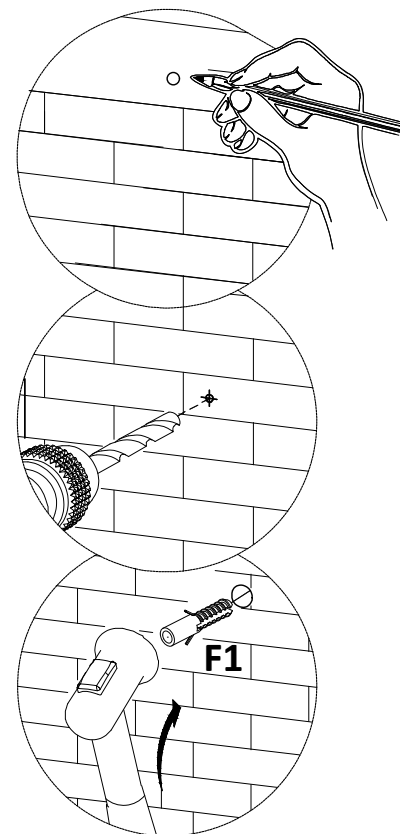
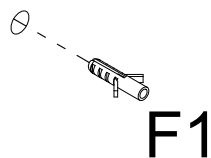
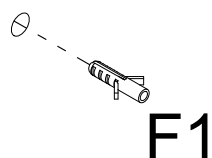
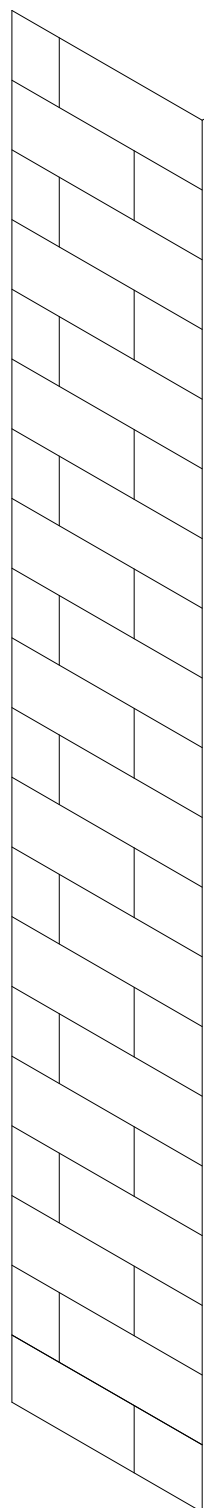

Step 57



WALL

DE: Markieren Sie zunächst die Wand mit einem Bleistift, bohren Sie das Loch bis zu einer Tiefe von etwa 30 mm und schlagen Sie das Zubehörteil (F1) hinein.

UK: First mark the wall with a pencil, drill the hole to a depth of about 30mm, and knock in the accessory (F1)

FR: Marquez d'abord le mur au crayon, percez un trou d'environ 30 mm de profondeur et enfoncez l'accessoire (F1).

IT: Prima tracciare un segno sulla parete con una matita, praticare un foro profondo circa 30 mm e inserire l'accessorio (F1).

ES: Primero marque la pared con un lápiz, taladre el agujero a una profundidad de unos 30 mm y encaje el accesorio (F1).

NL: Markeer eerst de muur met een potlood, boor het gat tot een diepte van ongeveer 30 mm en sla het hulpstuk (F1) erin.

SE: Markera först väggen med en penna, borra hålet till ett djup av cirka 30 mm och slå in tillbehöret (F1).

PL: Najpierw zaznacz ołówkiem miejsce na ścianie, wywierć otwór o głębokości około 30 mm i wbij element dodatkowy (F1).



F x 2

Step 58

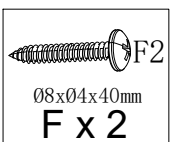
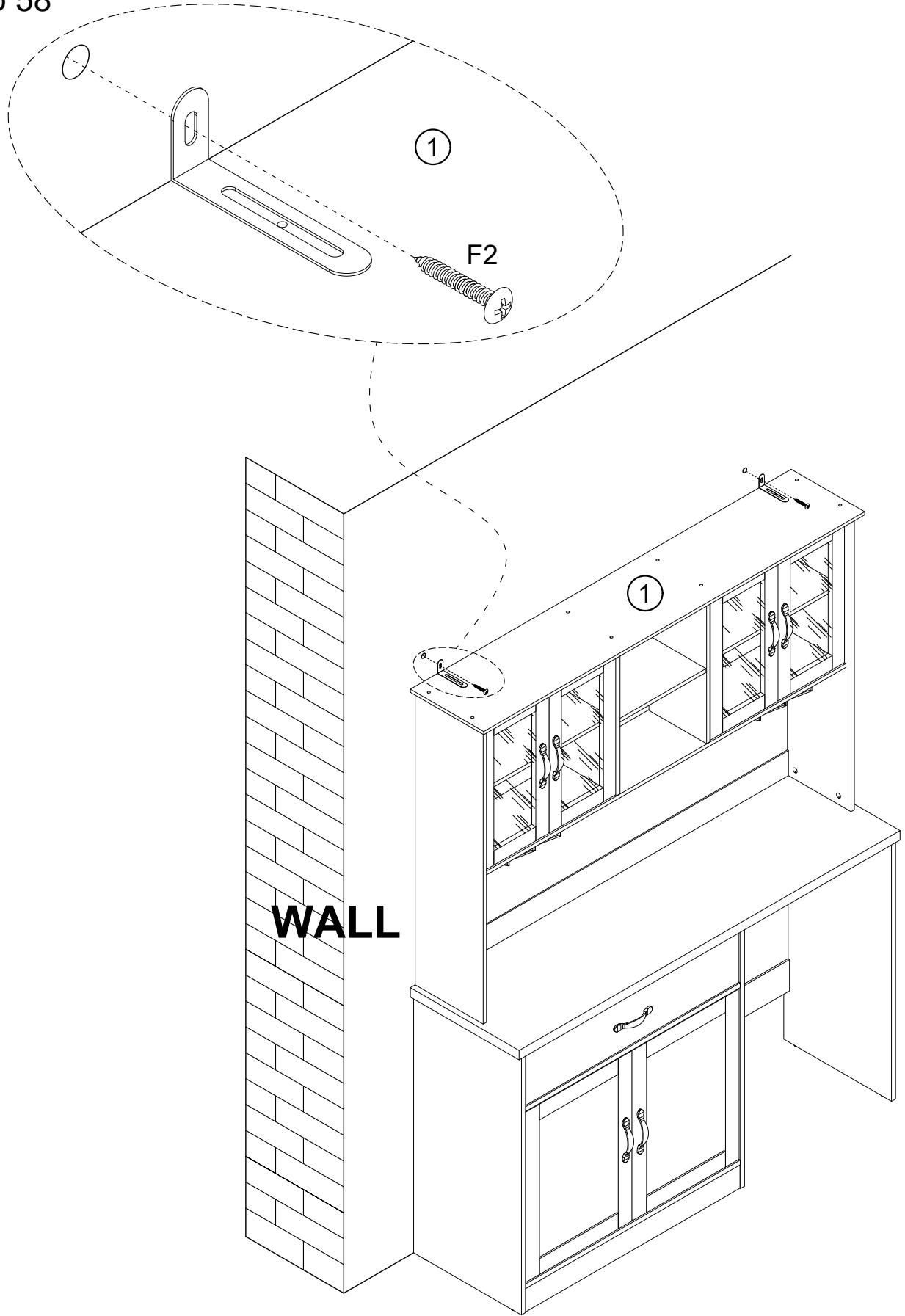

Step 59

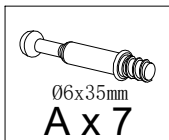
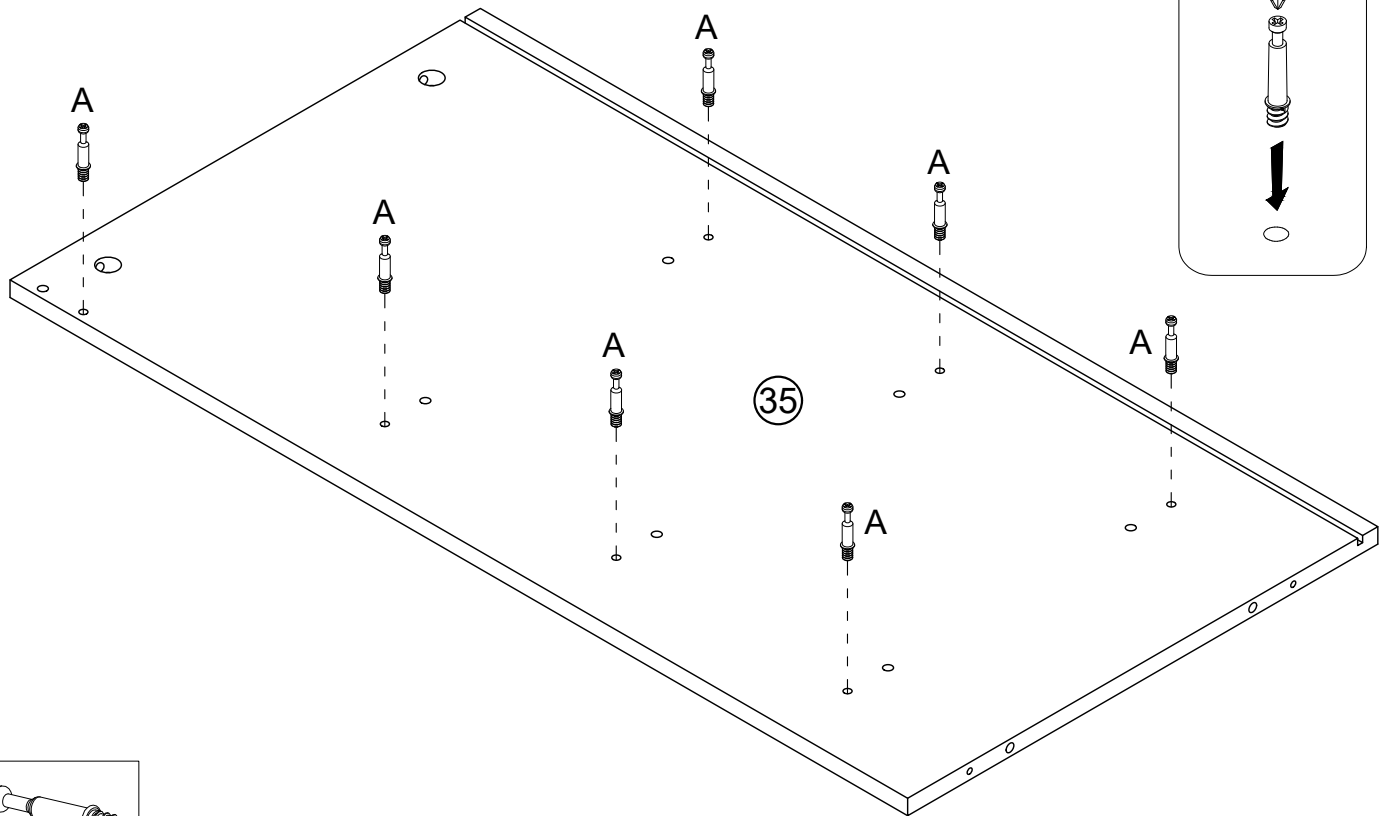

Step 60

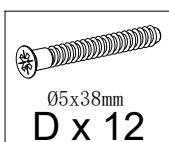
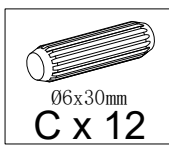
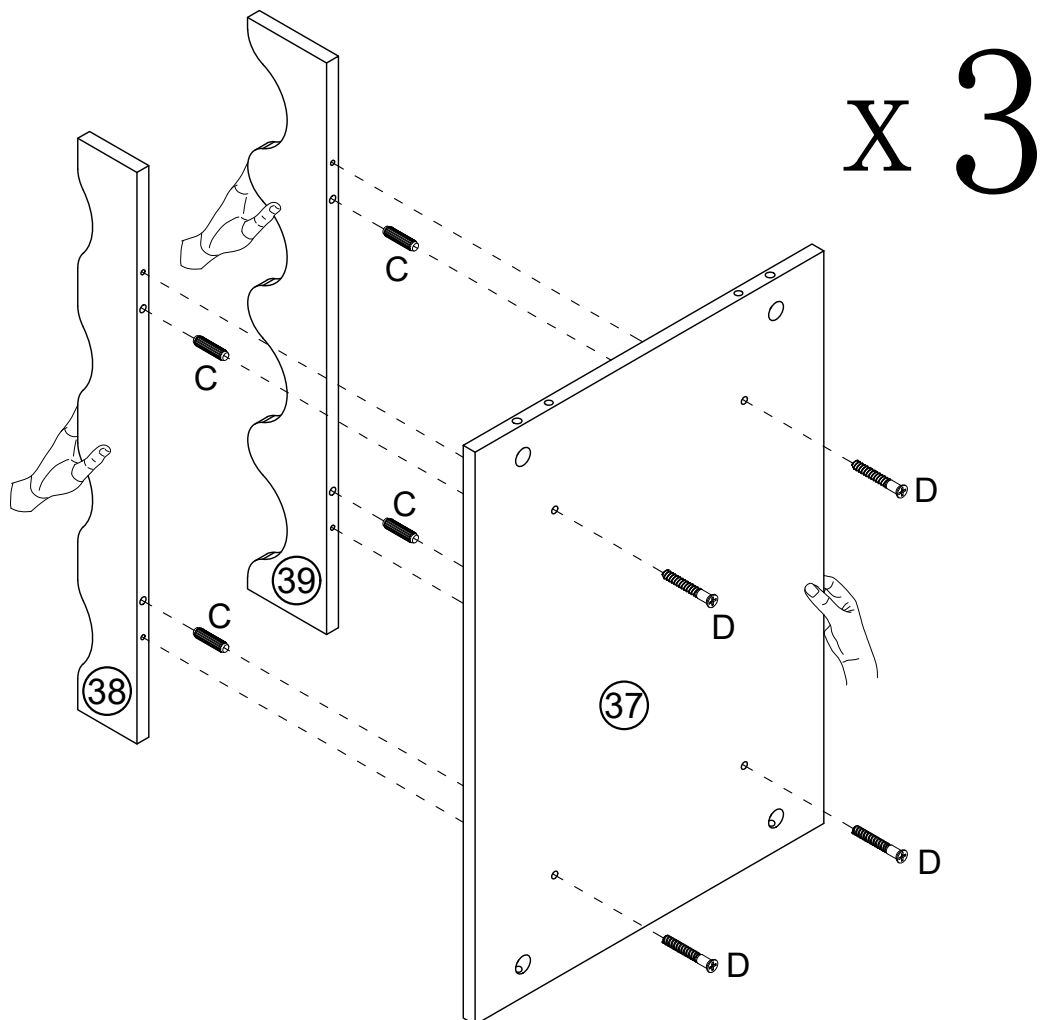
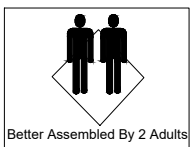

Step 61

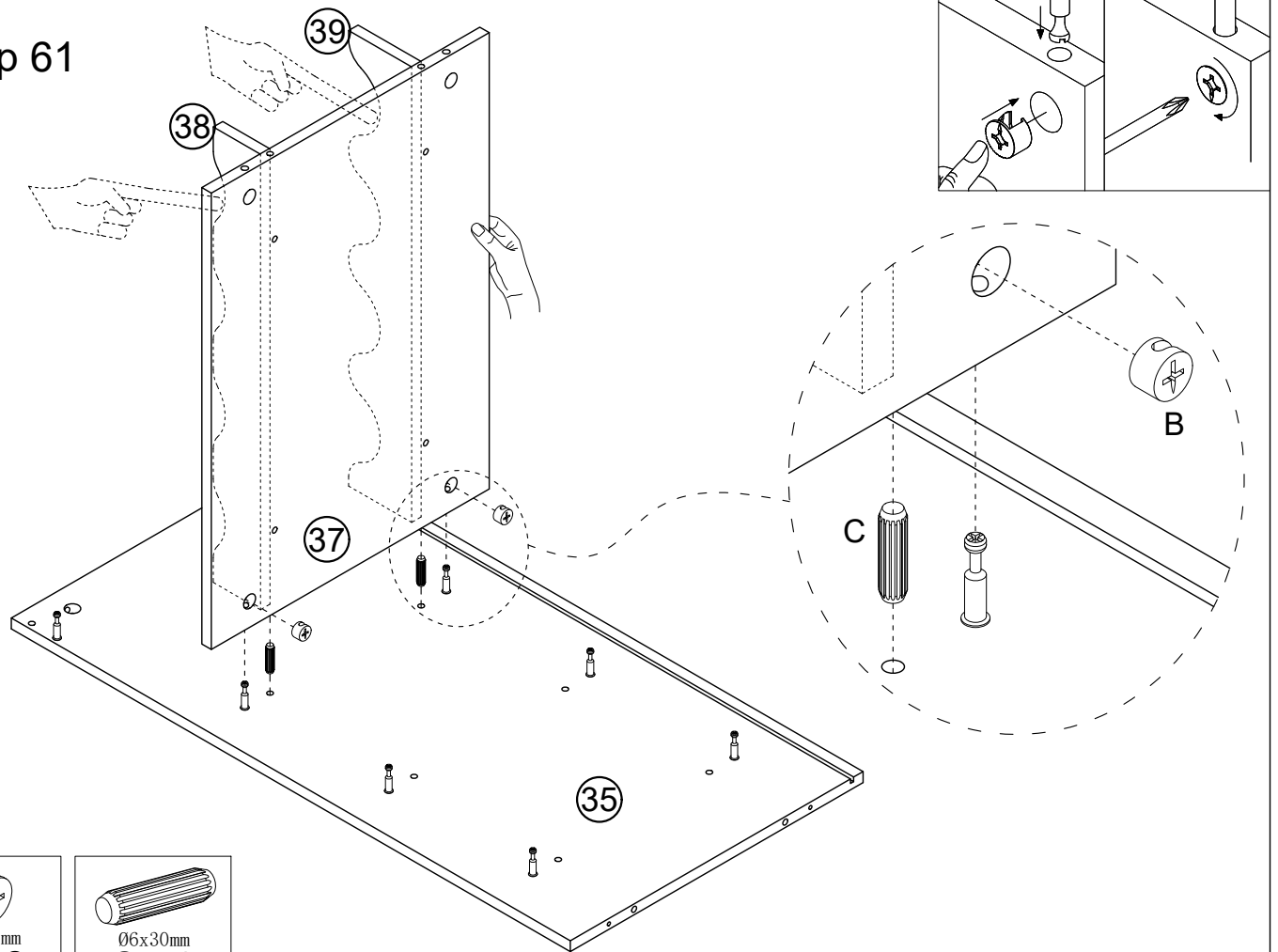

Step 62

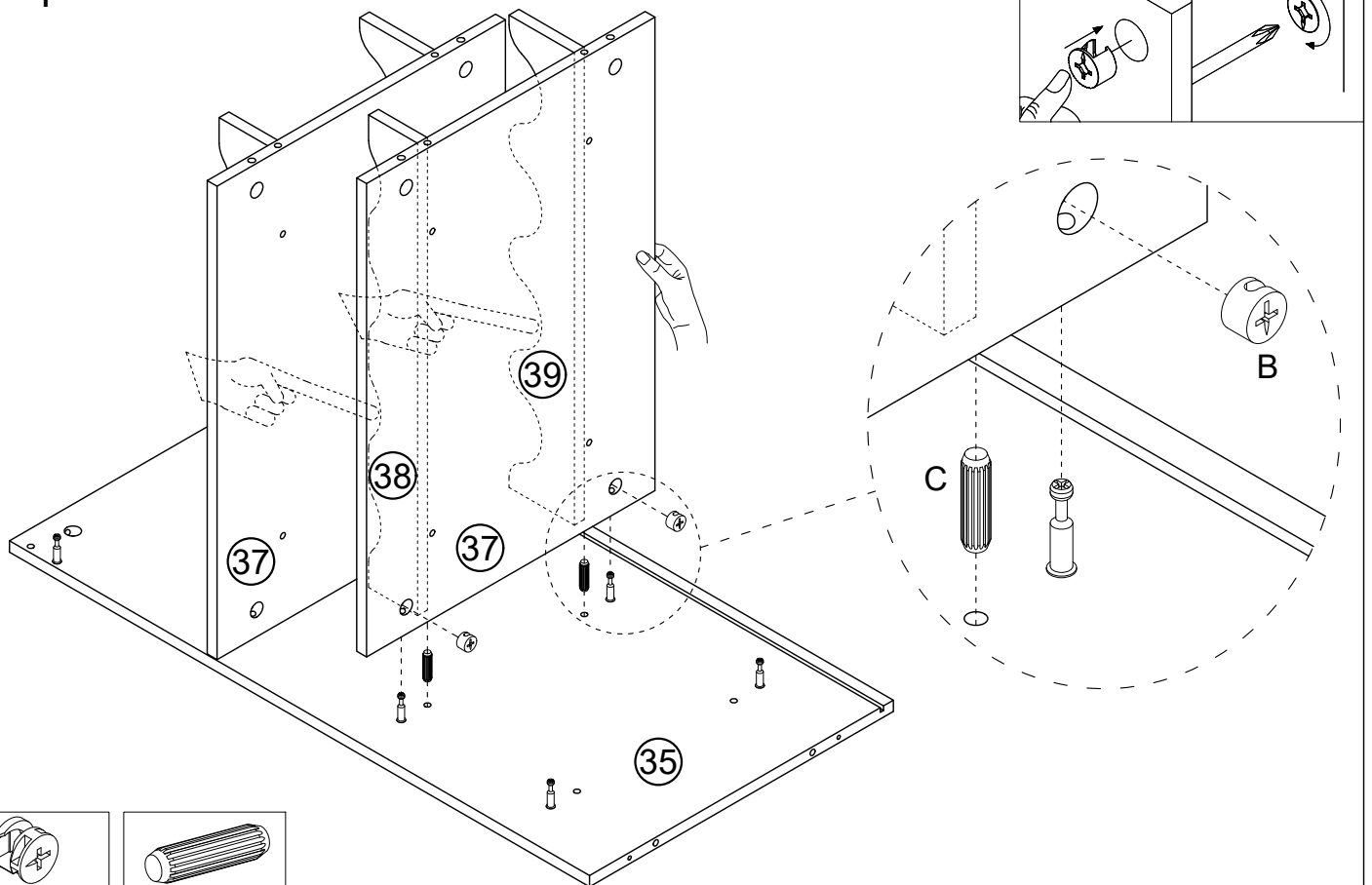

Step 63

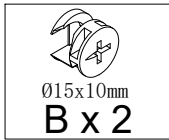
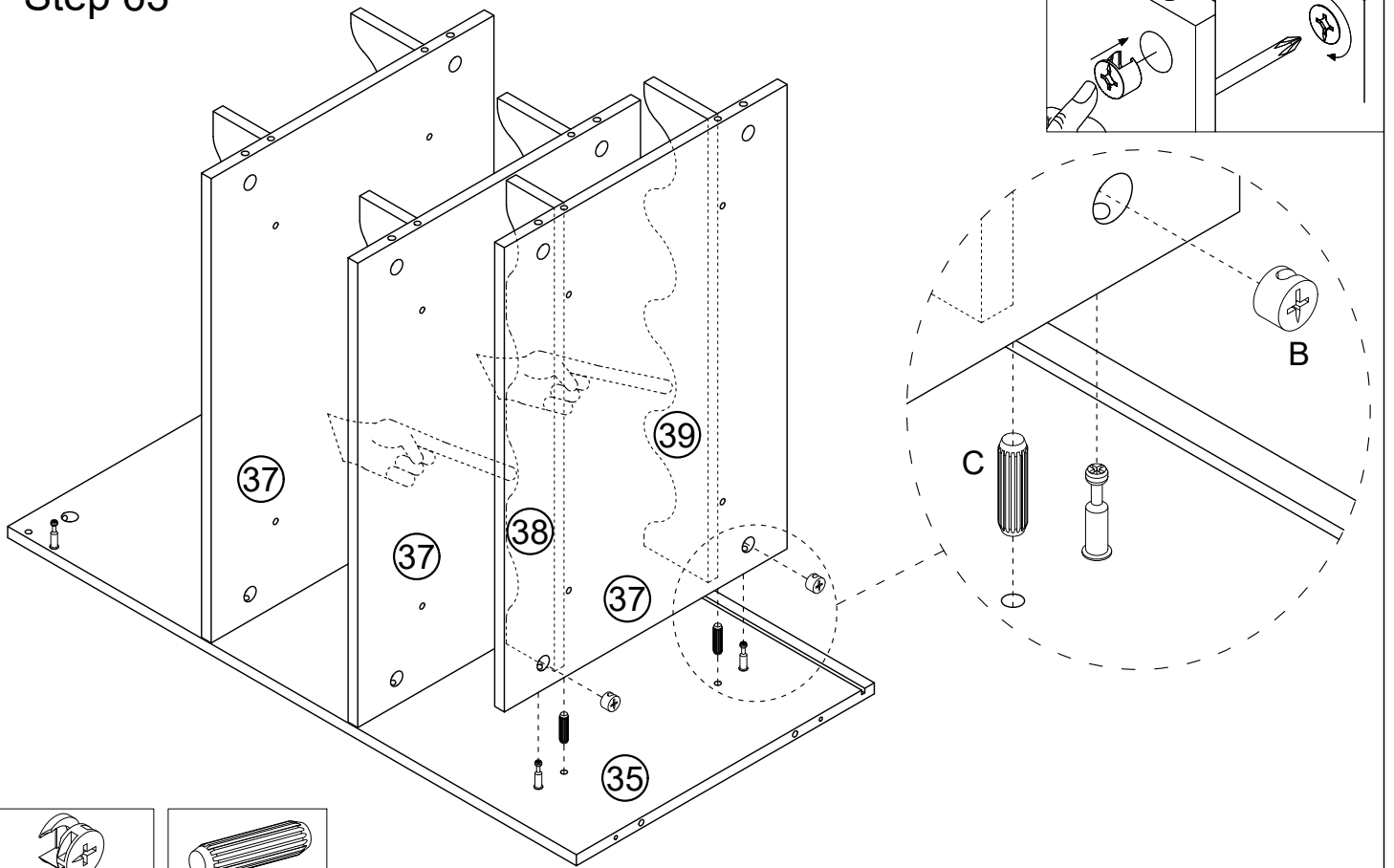

Step 64

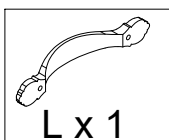
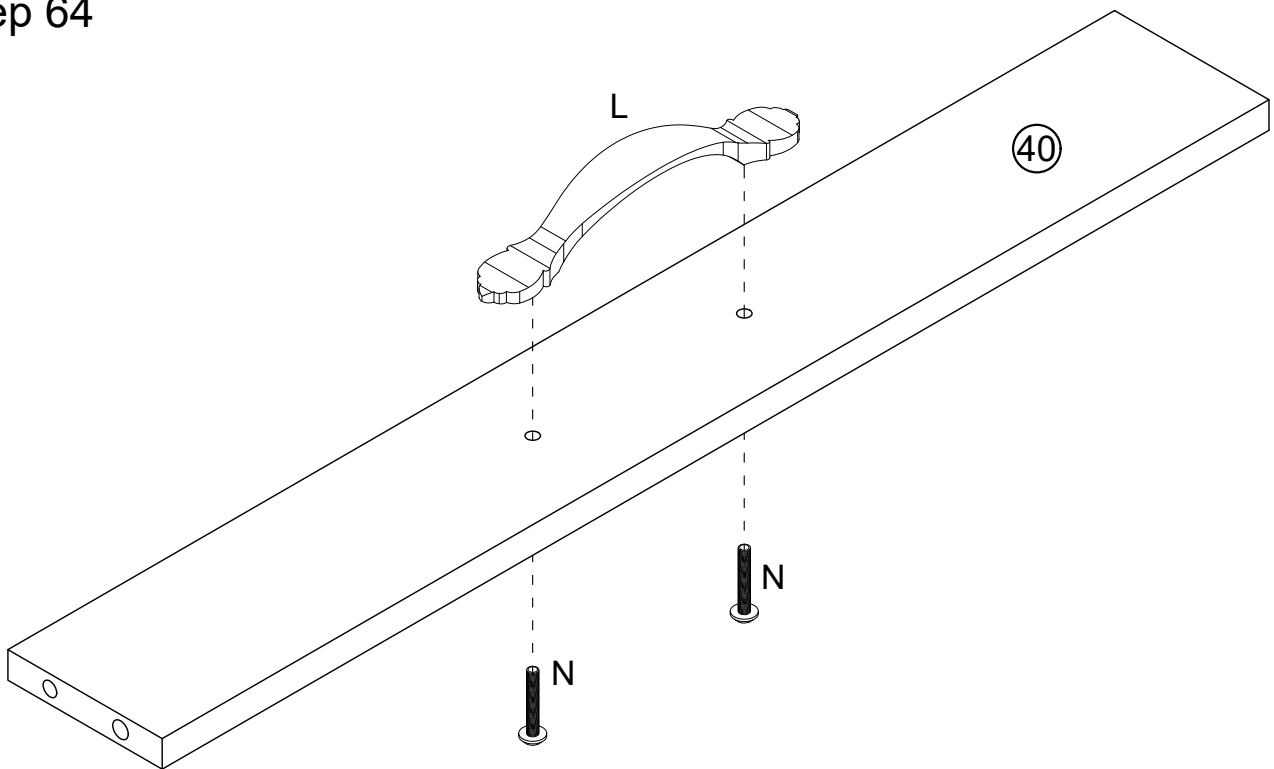

Step 65

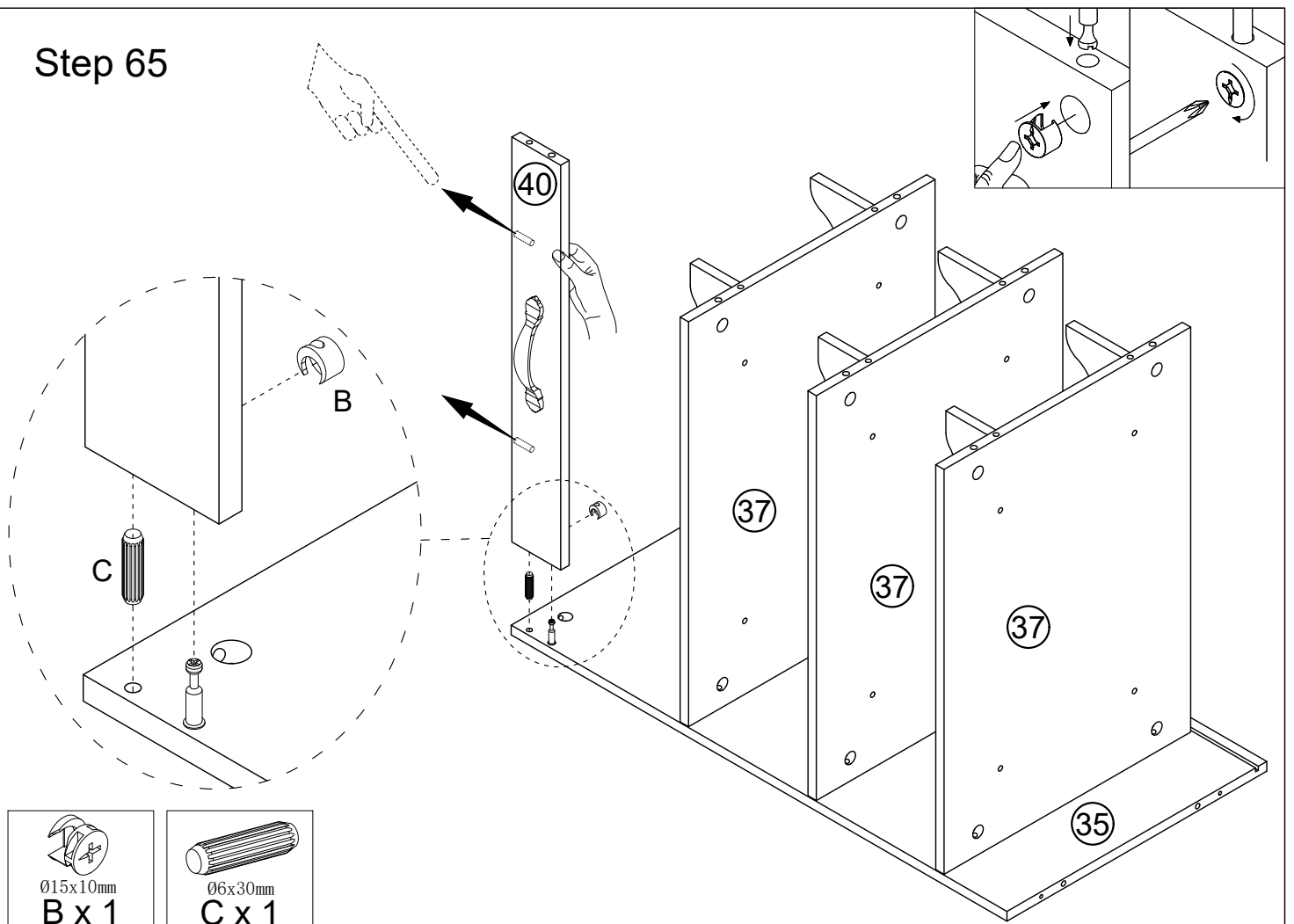

Step 66

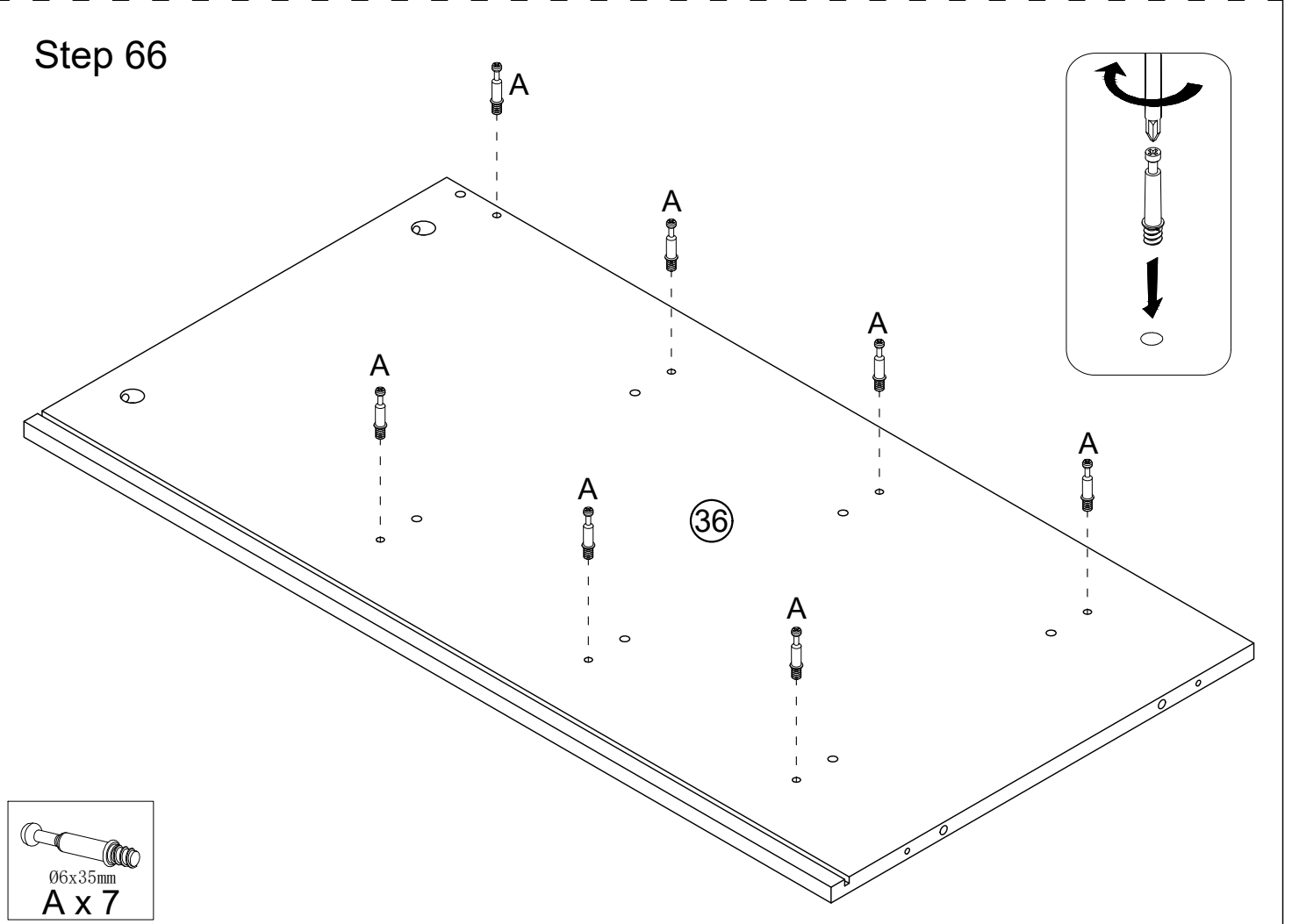

Step 67

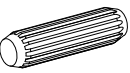
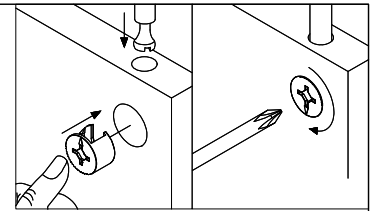
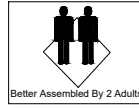
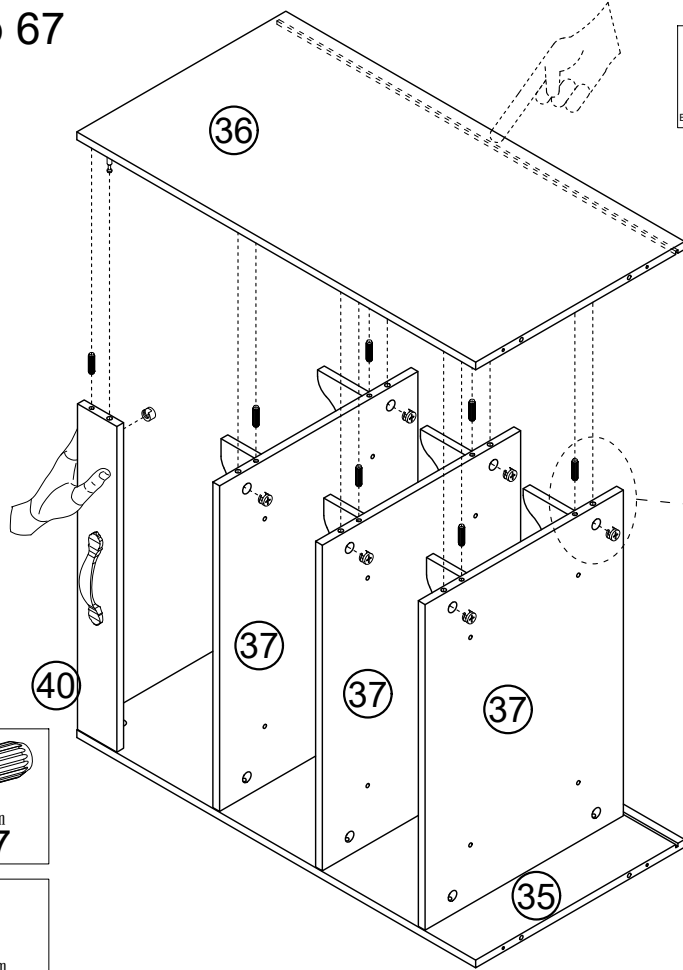

Ø6x30mm
C x 7



Ø15x10mm
B x 7

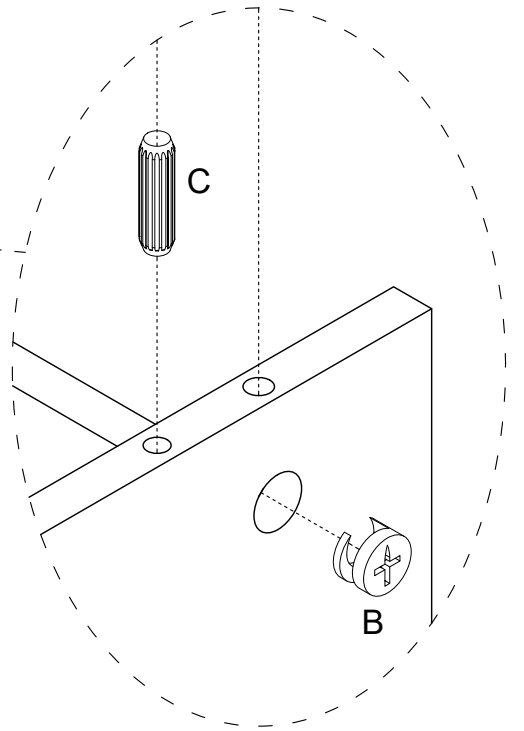

Step 68

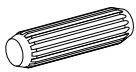
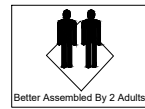
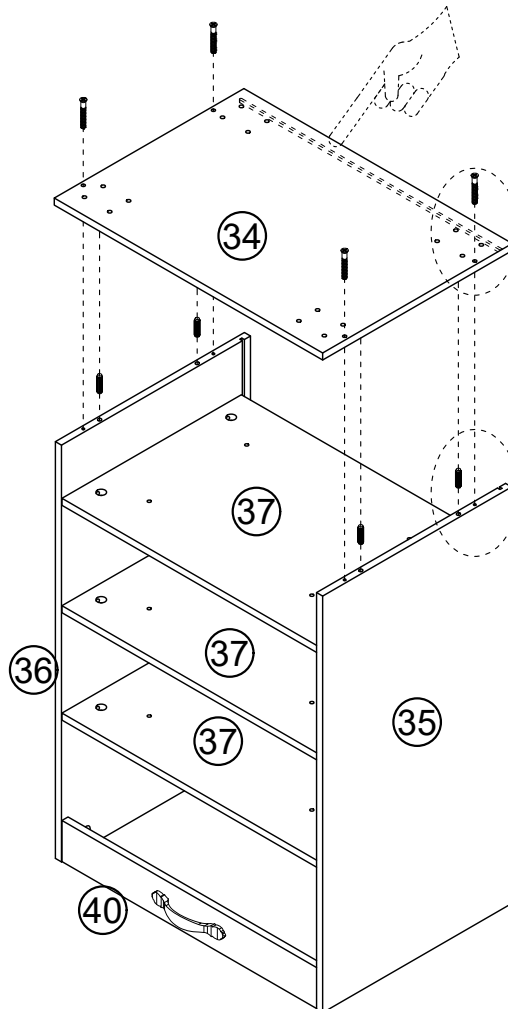
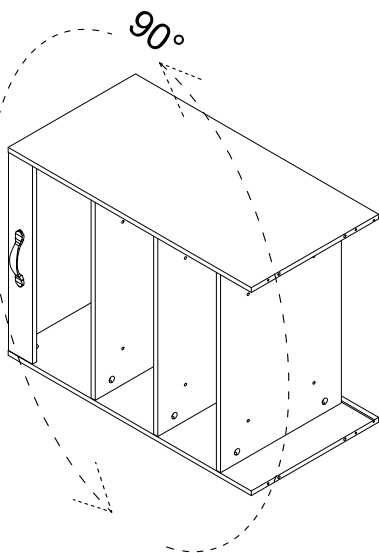

Ø6x30mm
C x 4



Ø5x38mm
D x 4

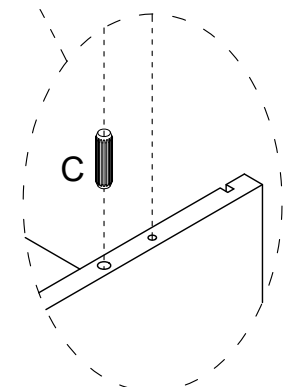
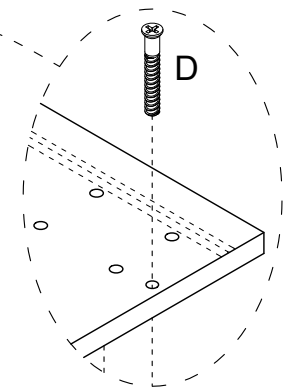

Step 69

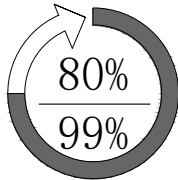

DE: Zuerst alle Schraubenbefestigungen zu 80 % festziehen, dann gleichmäßig auf 99 % festziehen.

UK: First lock all screw installations by 80%, then lock uniformly by 99%

FR: Commencez par serrer toutes les vis à 80 %, puis serrez uniformément à 99 %.

IT: Bloccare prima tutte le viti all'80%, quindi bloccare uniformemente al 99%.

ES: Primero, apriete todos los tornillos al 80 % y, a continuación, apriéte los uniformemente al 99 %.

NL: Draai eerst alle schroeven 80% vast en draai ze vervolgens gelijkmatig 99% vast.

SE: Lås först alla skruvinstitutioner till 80 % och lås sedan jämnt till 99 %.

PL: Najpierw dokręć wszystkie śruby o 80%, a następnie dokręć je równomiernie o 99%.

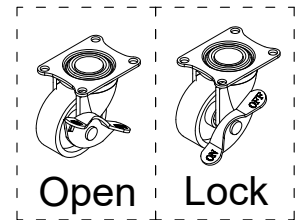

DE: Vor der Installation das Rad in die Nicht-Bremsposition bringen.

UK: Before installation adjust the wheel to the non-braking position

FR: Avant l'installation, réglez la roue en position de non-freinage.

IT: Prima dell'installazione, regolare la ruota in posizione di non frenata.

ES: Antes de la instalación, ajuste la rueda a la posición sin frenado.

NL: Stel het wiel vóór de installatie in op de niet-rempositie.

SE: Innan installation, ställ in hjulet i icke-bromsande läge.

PL: Przed montażem ustawić koło w pozycji bez hamowania.

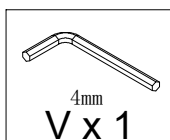
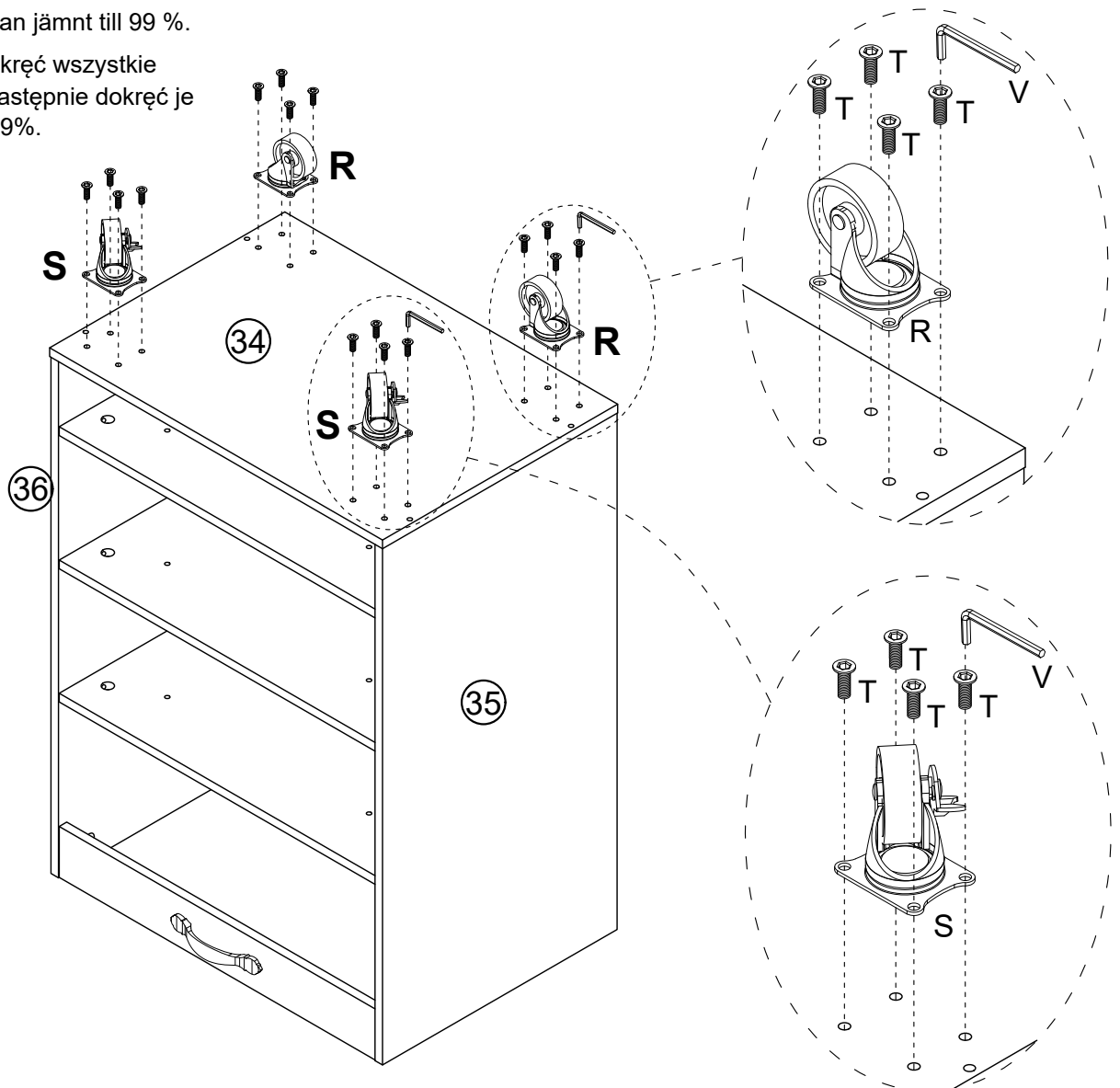

Step 70

DE: Die dünne Platte muss vollständig in die Nut eingeführt werden. Wenn das Einführen nicht reibungslos verläuft, können Sie versuchen, von vorne oder von hinten Druck auszuüben, um Anpassungen vorzunehmen, bis die dünne Platte vollständig in die Nut eingeführt ist.

UK: The thin plate needs to be fully inserted into the groove. If the insertion is not smooth, you can try pressing from the front or the back to make adjustments until the thin plate is fully inserted into the groove.

FR: La plaque mince doit être entièrement insérée dans la rainure. Si l'insertion ne se fait pas facilement, vous pouvez essayer d'appuyer à l'avant ou à l'arrière pour ajuster la plaque jusqu'à ce qu'elle soit entièrement insérée dans la rainure.

IT: La piastra sottile deve essere inserita completamente nella scanalatura. Se l'inserimento non avviene in modo fluido, è possibile provare a premere dalla parte anteriore o posteriore per effettuare le regolazioni necessarie fino a quando la piastra sottile non è inserita completamente nella scanalatura.

ES: La placa delgada debe insertarse completamente en la ranura. Si la inserción no es fluida, puede intentar presionar desde la parte delantera o trasera para realizar ajustes hasta que la placa delgada se inserte completamente en la ranura.

NL: De dunne plaat moet volledig in de groef worden gestoken. Als het insteken niet soepel verloopt, kunt u proberen vanaf de voorkant of de achterkant druk uit te oefenen om aanpassingen te maken totdat de dunne plaat volledig in de groef is gestoken.

SE: Den tunna plattan måste sättas in helt i spåret. Om den inte går in smidigt kan du försöka trycka från framsidan eller baksidan för att justera tills den tunna plattan är helt insatt i spåret.

PL: Cienką płytkę należy całkowicie wsunąć w rowek. Jeśli wsuwanie nie przebiega płynnie, można spróbować docisnąć ją od przodu lub od tyłu, dopasowując ją tak, aby całkowicie wsunęła się w rowek.

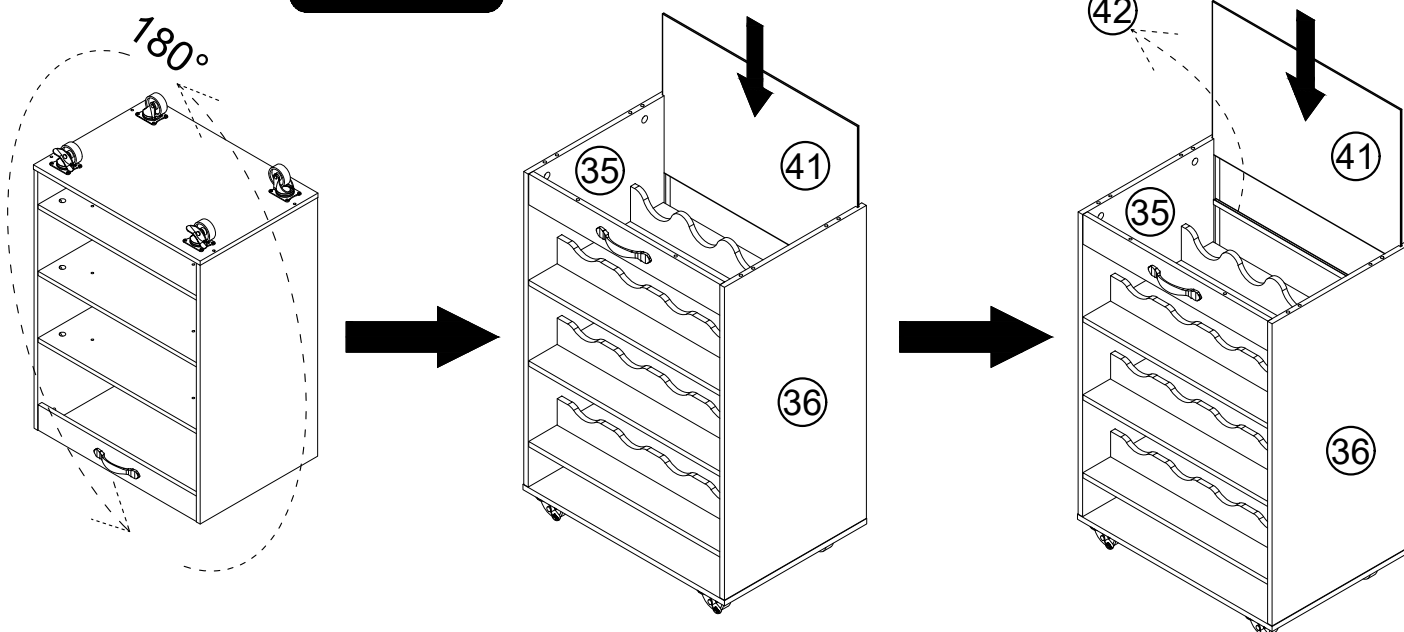

Step 71

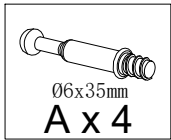

Step 72

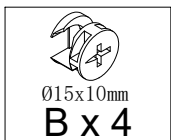
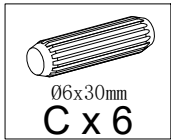
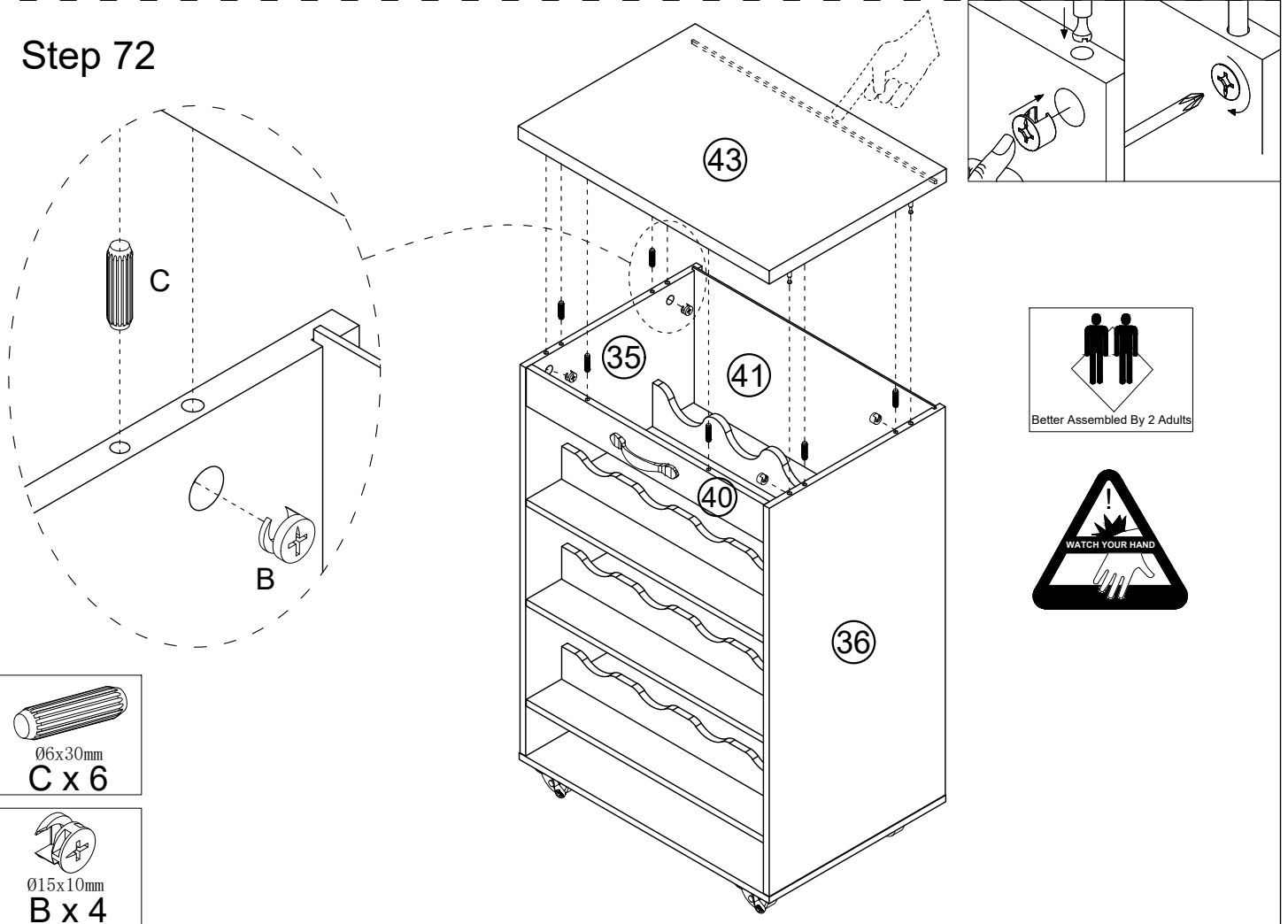

Step 73

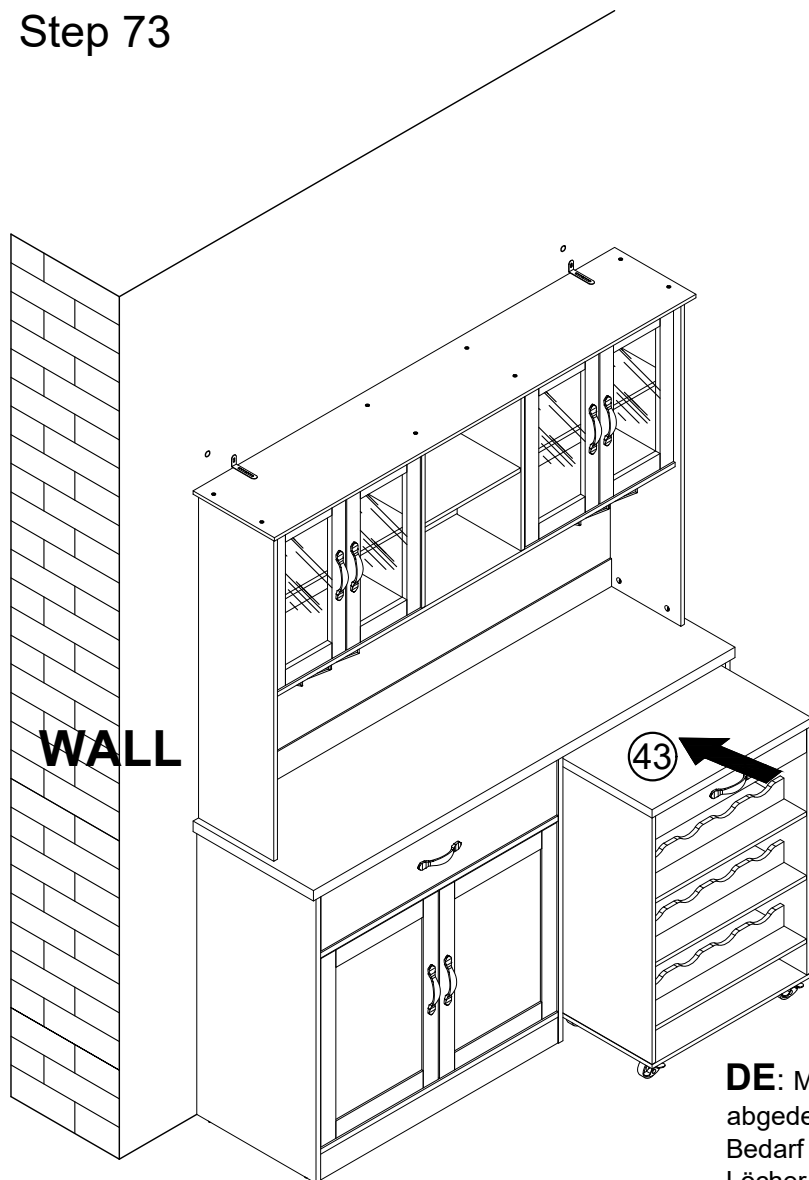

Open



Lock

DE: Der Tisch kann durch Einstellen des Radbremssystems verschoben oder gesichert werden.

UK: The table can be moved or secured by adjusting the wheel braking system

FR: La table peut être déplacée ou fixée en réglant le système de freinage des roulettes.

IT: Il tavolo può essere spostato o fissato regolando il sistema frenante delle ruote.

ES: La mesa se puede mover o fijar ajustando el sistema de frenado de las ruedas.

NL: De tafel kan worden verplaatst of vastgezet door het remsysteem van de wielen aan te passen.

SE: Bordet kan flyttas eller säkras genom att justera hjulbromssystemet.

PL: Stół można przesuwać lub unieruchamiać, regulując układ hamulcowy kół.

DE: Mit Ausnahme der bereits mit I abgedeckten Löcher können Kunden je nach Bedarf entscheiden, ob sie die verbleibenden Löcher mit I abdecken möchten.

UK: Except for the holes already covered with I, customers may choose whether to cover the remaining holes with I based on their requirements

FR: À l'exception des trous déjà recouverts de I, les clients peuvent choisir de recouvrir ou non les trous restants avec du I en fonction de leurs besoins.

IT: Ad eccezione dei fori già coperti con I, i clienti possono scegliere se coprire i fori rimanenti con I in base alle loro esigenze.

ES: Excepto los orificios ya cubiertos con I, los clientes pueden elegir si desean cubrir los orificios restantes con I en función de sus necesidades.

NL: Behalve voor de gaten die al met I zijn afgedekt, kunnen klanten op basis van hun vereisten kiezen of ze de resterende gaten met I willen afdekken.

SE: Förutom de hål som redan täckts med I kan kunderna välja om de vill täcka de återstående hålen med I utifrån sina behov.

PL: Z wyjątkiem otworów już pokrytych I, klienci mogą zdecydować, czy pozostałe otwory mają być pokryte I, w zależności od swoich wymagań.

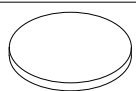
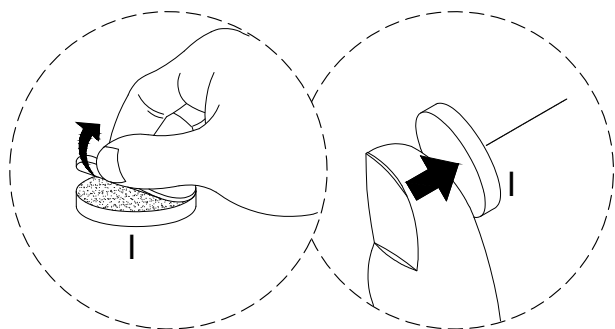

I x 25

Step 74

Installation completed,
please enjoy this product to the fullest,
Wishing you a pleasant use

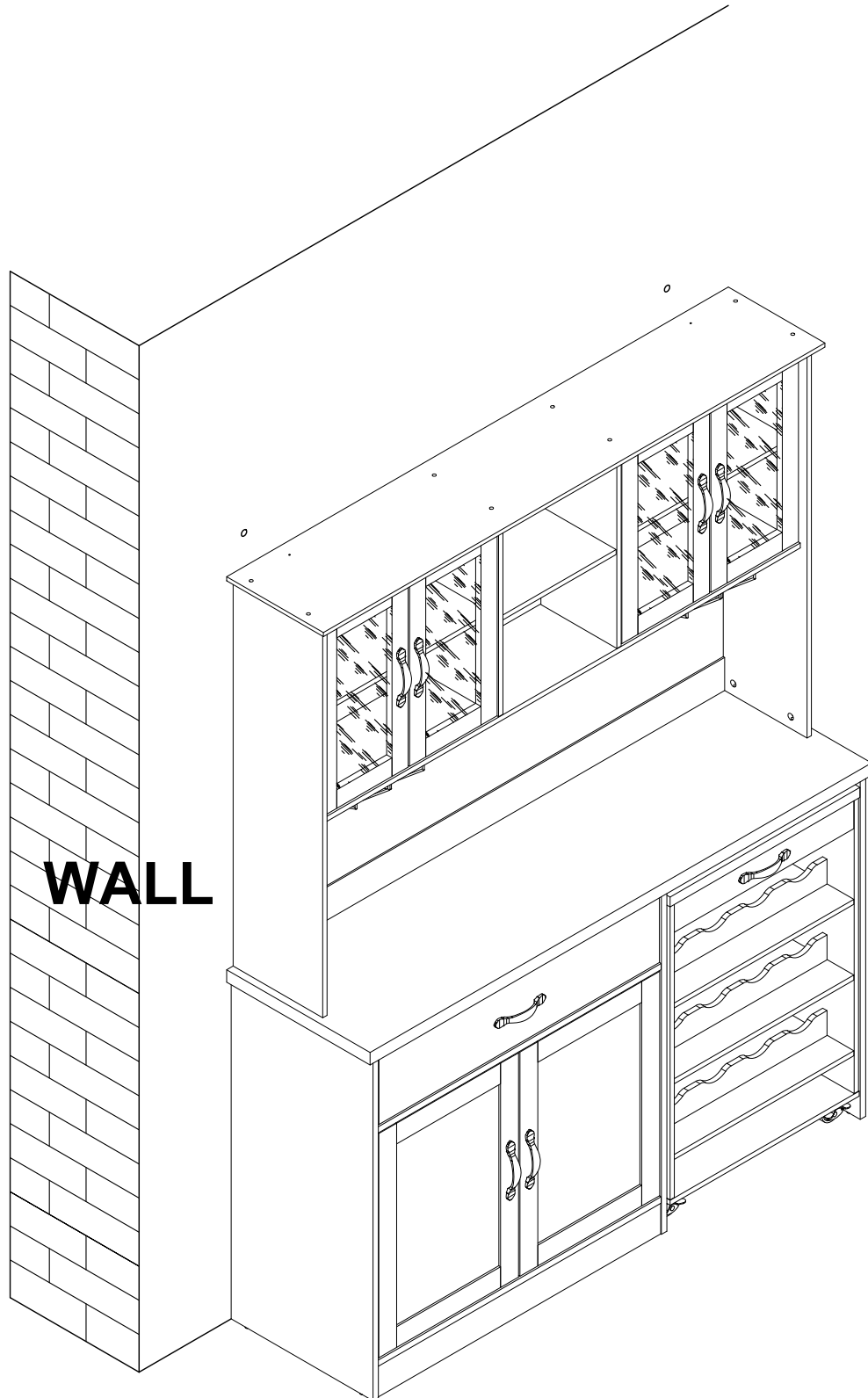

CERTIFICATE OF COMPLIANCE

No.: AiTSZ-250710061C-C01

Product: 5050 RGB LED Strip Lights with Bluetooth App Controller
Trade Mark: N/A
Model: LED 5050 RGB
Applicant: Shenzhen Pinchengxin Technology Co., Ltd
Address: 3rd floor, 8 building Yuanling industrial zon, No. 39 Yuanlingcun road,Shiyan street, Bao'an district, Shenzhen
Manufacture: Shenzhen Pinchengxin Technology Co., Ltd
Address: 3rd floor, 8 building Yuanling industrial zon, No. 39 Yuanlingcun road,Shiyan street, Bao'an district, Shenzhen

The test sample of product has passed the test according to requirements of the following standards:

	Standard(s):	Test report(s) No.:
Article 3.1a)	EN IEC 62368-1:2020+A11:2020	AiTSZ-250710061S
	EN 62479: 2010 EN 50663: 2017	AiTSZ-250710061CW3
Article 3.1b)	ETSI EN 301 489-1 V2.2.3 (2019-11) ETSI EN 301 489-17 V3.2.4 (2020-09)	AiTSZ-250710061CW1
Article 3.2)	ETSI EN 300 328 V2.2.2 (2019-07)	AiTSZ-250710061CW2

Based on the voluntary assessment of the product sample and technical file, we confirm that the above-mentioned product meets the essential requirements of the Radio Equipment Directive (RED) 2014/53/EU.

The CE mark as show below can be used, under the responsibility of the manufacturer or the importer, after completion of an EC declaration of conformity and follow the CE mark usage rules.



Approved by/Date: Sean She July 23, 2025
Sean She



The statement is based on a single evaluation of one sample of above mentioned products. It does not imply an assessment of the whole production and does not permit the use of the test lab's logo.

Guangdong Asia Hongke Test Technology Limited

B1/F, Building 11, Junfeng Industrial Park, Chongqing Road, Heping Community, Fuhai Street,
Bao'an District, Shenzhen, Guangdong, China

www.aitek.org.cn

E-mail:info@aitek.org.cn



CERTIFICATE OF COMPLIANCE

No.: AiTSZ-250710061C-C01

Product: 5050 RGB LED Strip Lights with Bluetooth App Controller
Trade Mark: N/A
Model: LED 5050 RGB
Applicant: Shenzhen Pinchengxin Technology Co., Ltd
Address: 3rd floor, 8 building Yuanling industrial zon, No. 39 Yuanlingcun road,Shiyan street, Bao'an district, Shenzhen
Manufacture: Shenzhen Pinchengxin Technology Co., Ltd
Address: 3rd floor, 8 building Yuanling industrial zon, No. 39 Yuanlingcun road,Shiyan street, Bao'an district, Shenzhen

The test sample of product has passed the test according to requirements of the following standards:

Standard(s):	Test report(s) No.:
EN 55032:2015+A11:2020 EN 55035:2017+A11:2020	AiTSZ-250710061CE1

Based on the voluntary assessment of the product sample and technical file, we confirm that the above-mentioned product meets the essential requirements of the Electromagnetic Compatibility (EMC) Directive 2014/30/EU.

The CE mark as show below can be used, under the responsibility of the manufacturer or the importer, after completion of an EC declaration of conformity and follow the CE mark usage rules.



Approved by/Date:

Allen Wang

Allen.Wang

Jul. 23, 2025



The statement is based on a single evaluation of one sample of above mentioned products. It does not imply an assessment of the whole production and does not permit the use of the test lab's logo.

Guangdong Asia Hongke Test Technology Limited

B1/F, Building 11, Junfeng Industrial Park, Chongqing Road, Heping Community, Fuhai Street,
Bao'an District, Shenzhen, Guangdong, China
www.aitek.org.cn
E-mail:info@aitek.org.cn



Certificate of Compliance

Certificate No.: AiTSZ-250710061RC09

The EUT described above has been consolidated by us and found in compliance with the council RoHS 2.0 Directive(EU)2015/863and(EU)2017/2102 amending Annex I to Directive2011/65/EU.

Applicant : Shenzhen Pinchengxin Technology Co., Ltd
Address : 3rd floor, 8 building Yuanling industrial zon, No. 39 Yuanlingcun road, Shiyang street, Bao'an district, Shenzhen
Manufacturer : Shenzhen Pinchengxin Technology Co., Ltd
Address : 3rd floor, 8 building Yuanling industrial zon, No. 39 Yuanlingcun road, Shiyang street, Bao'an district, Shenzhen
Product : 5050 RGB LED Strip Lights with Bluetooth App Controller
Model No. : LED 5050 RGB
Trade mark : N/A
Test Report No. : AiTSZ-250710061R

Test Standards:

IEC 62321-3-1: 2013
IEC 62321-4:2013+AMD1:2017 CSV
IEC 62321-5:2013
IEC 62321-6:2015
IEC 62321-7-1:2015
IEC 62321-7-2:2017
IEC 62321-8:2017

RoHS

Lizhen

Lizhen

Date: Jul.18, 2025



The statement is based on a single evaluation of one sample of above mentioned products. It does not imply an assessment of the whole production and does not permit the use of the test lab logo.



Guangdong Asia Hongke Test Technology Co.,Ltd.

B1/F, Building 11, Junfeng Industrial Park, Chongqing Road, Heping Community, Fuhai Street, Bao'an District, Shenzhen, Guangdong, China

Tel:+86. 0755-23096763

<https://www.aitek.org.cn>

E-mail:info@aitek.org.cn