

# LEOVIA 250

## WYMIARY ELEMENTÓW PART GUIDE MASSE DER BAUTEILE

- (D) Montageanleitung  
 (NL) Handleiding voor de montage  
 (TR) Montaj talimatı  
 (F) Notice de montage  
 (CZ) Montážní návod  
 (HU) Szerelési útmutató  
 (GB) Assembly Instructions  
 (PL) Instrukcja montażu  
 (RU) Инструкция по монтажу  
 (IT) Istruzioni di montaggio  
 (SK) Návod na montáž  
 (RO) Instrucțiunile de montaj

No.	L[mm]	W[mm]	T[mm]	Stc.	Coll.
1	2468	564	16	1	2/6
2	2468	581	16	1	2/6
3	585	2150	16	1	1/6
4	585	2150	16	1	1/6
5	474	1644	16	1	1/6
6	474	1644	16	1	1/6
7	2468	474	16	1	2/6
8	474	357	16	1	1/6
9	2468	100	16	2	2/6
10	726	474	16	1	3/6
11	855	474	16	6	3/6
12	2150	38	22	2	1/6
13	2050	435	3	4	2/6
14	2050	370	3	2	2/6
16	2468	70	16	1	2/6
17	458	686	3	2	3/6
18	668	100	16	2	3/6
19	450	120	16	2	3/6
20	450	120	16	2	3/6
21	720	185	16	2	3/6

No.	L[mm]	W[mm]	T[mm]	Stc.	Coll.
22	498	850	16	1	4/6
23	498	850	16	1	4/6
25	498	850	16	1	4/6
26	498	850	16	1	4/6

No.	L[mm]	W[mm]	T[mm]	Stc.	Coll.
22	498	850	16	1	5/6
23	498	850	16	1	5/6
25	498	850	16	1	5/6
26	498	850	16	1	5/6

No.	L[mm]	W[mm]	T[mm]	Stc.	Coll.
22	498	850	16	1	6/6
23	498	850	16	1	6/6
24	498	850	16	2	6/6

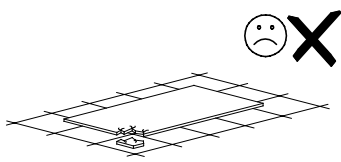
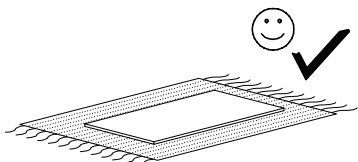
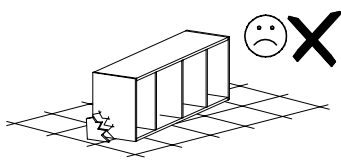
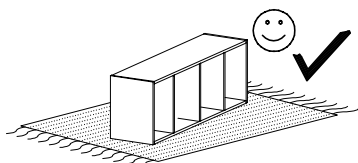
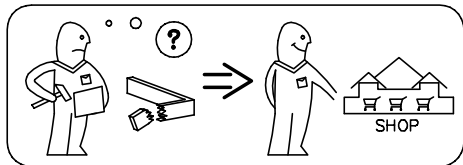
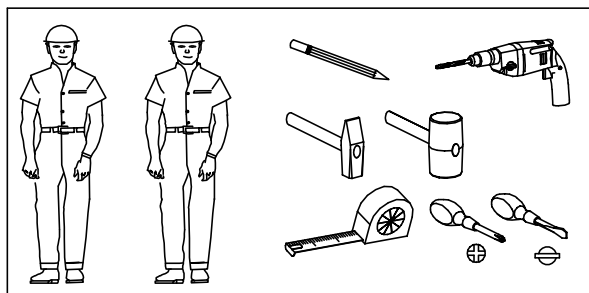
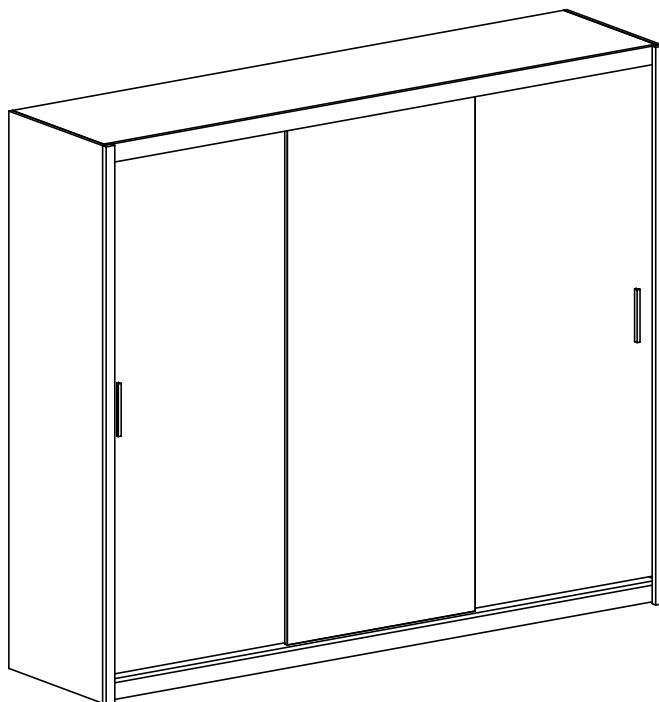

### Uwaga – Upozornění – Achtung – Attention – Caution – Figyelem Attenzione – Opgelet – Внимание – Atentie – Upozornenie – Dikkat

PL	Czyszczenie należy wykonać wyłącznie za pomocą ściereczki lub lekko nawilżonego ręcznika. Nie stosować środków czyszczących do szorowania.
CZ	Čistění je nutné vykonávat výhradně pomoci utěrky nebo lehce navlhčeného ručniku. Nepoužívejte čističí prostředky obsahující abrazivní částice.
D	Bitte nur mit einem Staubtuch oder leicht feuchtem Lappen reinigen. Keine scheuernden Putzmittel verwenden.
GB	Please only clean with duster or damp cloth. Do not use any abrasive cleaners.
F	Le nettoyage se fait uniquement à l'aide d'un torchon ou d'une serviette légèrement mouillée.
HU	A tisztítás kizárólag törölruha vagy enyhén nedvesített törölköző segítségével végezhető. Súroló hatású tisztítószereket nem szabad használni.
I	Pulire esclusivamente con un panno o un asciugamano umido.
NL	Reinig allen met een stofdoek of een lichtjes vochtige doek. Gebruik geen schurende poetsmiddelen.
RU	Очищайте от пыли тряпкой или слегка влажной ветошью. Не допускаются применение чистящих средств, не пред-назначенных для ухода за мебелью.
RO	Curabare trebuie efectuată numai cu o cârpă sau cu un prosop usor umzeit. Nu utilizati agenți de curabare abrazivi.
SK	Čistení je nutné vykonávat výhradne pomoci utierky nebo ľahko zvlhnutým ručníkom. Nepoužívajte čistiaci prostriedky obsahujúci abrazívni častice.
TR	Lütfen sadece bir toz bezile veya hafif yumusak bir bezle siliniz. Asindirici temizlik malzemeleri kullanmayiniz.

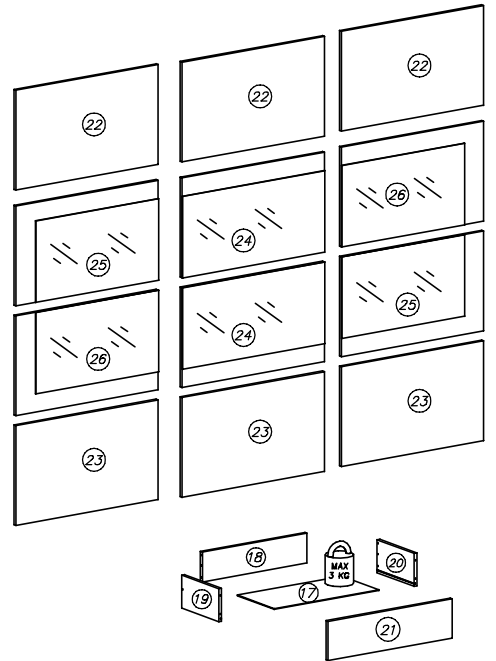
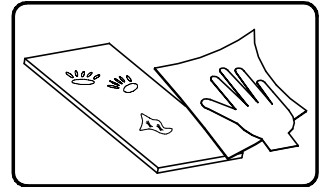
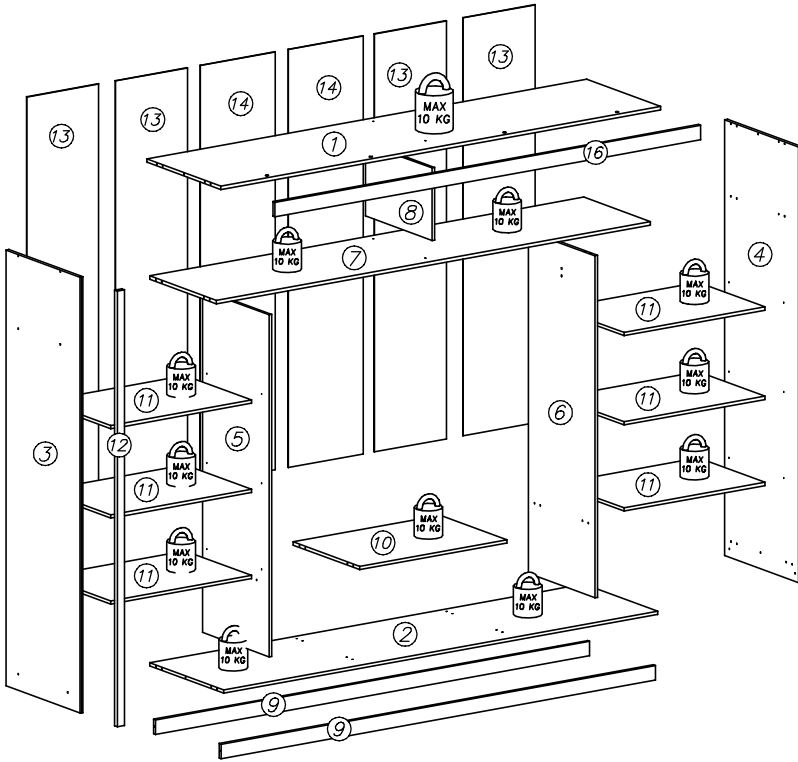
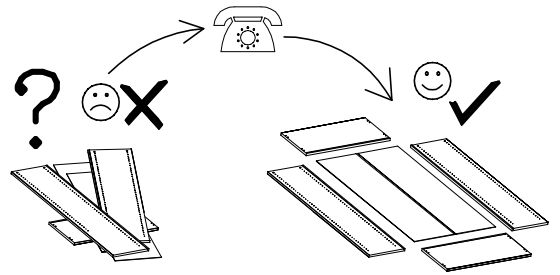
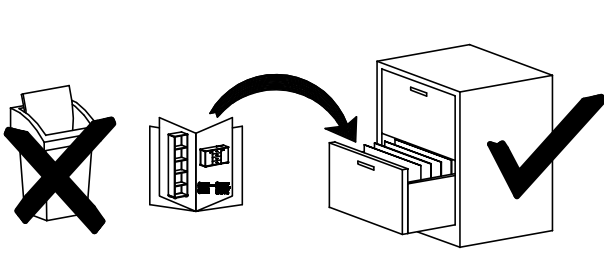

**W9** OŚWIETLENIE LED OPCJONALNIE  
 OPTIONAL LED LIGHTING  
 WAHLWEISE LED-BELEUCHTUNG

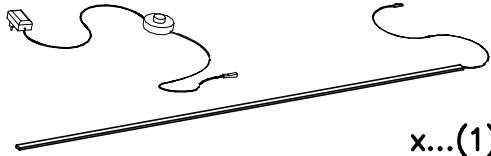

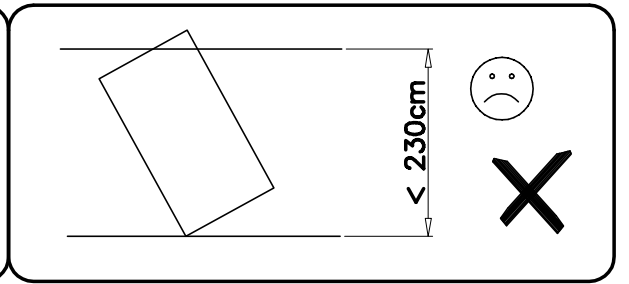
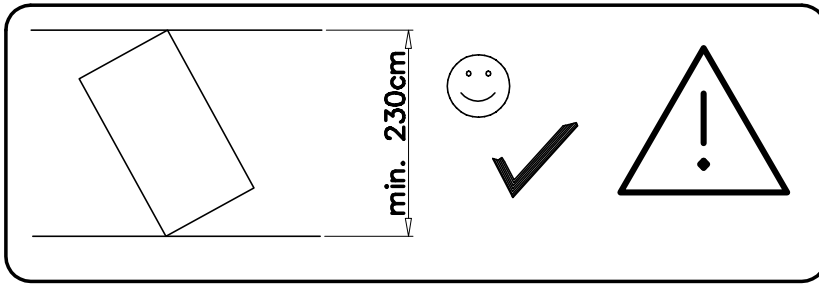
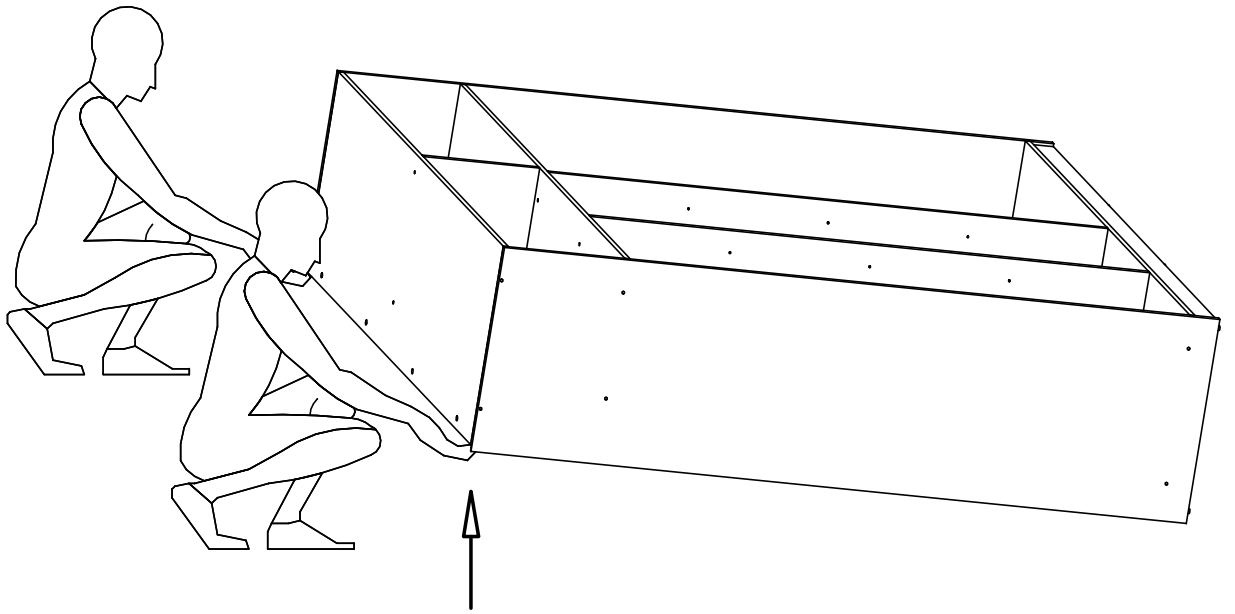

<b>G36</b> 3x13 x...(10) <b>G29</b> 6x11 x...(8) <b>E32</b> x...(6)					
<b>H7</b> x...(2)	<b>T9</b> x...(10)	<b>T1</b> x...(2)	<b>G20</b> 5x13 x...(10)		
<b>T13</b> x...(12)	<b>W1</b> GLUE, LEIM, LEPIDLO, LIM x...(1)	<b>T19</b> x...(2)	<b>F1</b> x...(24)	<b>P4</b> x...(8)	
<b>S17</b> x...(32)	<b>S1a</b> x...(2)	<b>S1b</b> x...(3)	<b>M3</b> x...(27)	<b>T5</b> x...(6)	<b>K1</b> Ø15x12 x...(4)
<b>I12</b> x...(4)	<b>S5</b> x...(1)	<b>W4</b> x...(120)	<b>G31</b> 4x13 x...(24)	<b>T4</b> x...(6)	<b>K5</b> x...(4)
<b>I17</b> x...(32)	<b>A1</b> Ø7x50 x...(32)	<b>B1</b> Ø8x35 x...(56)	<b>S18</b> x...(2)	<b>W2</b> x...(1)	<b>G19</b> 6x13 x...(126)

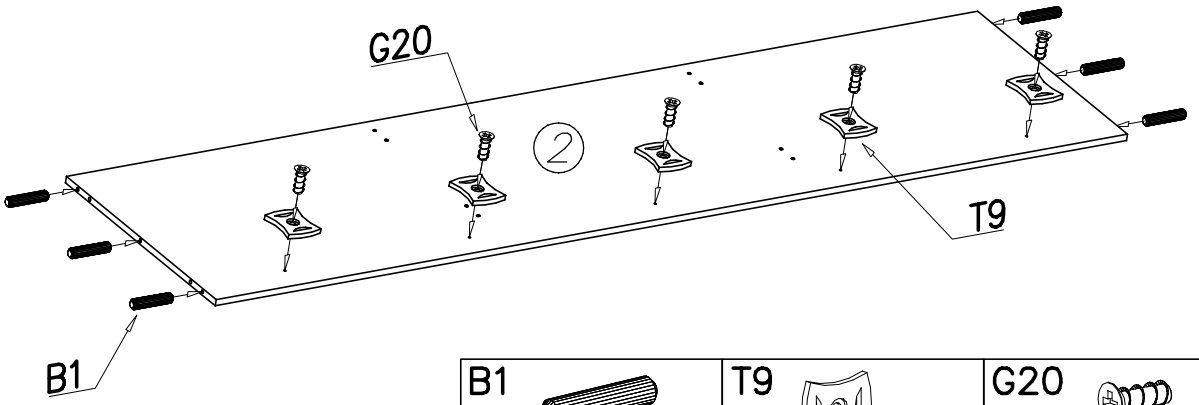
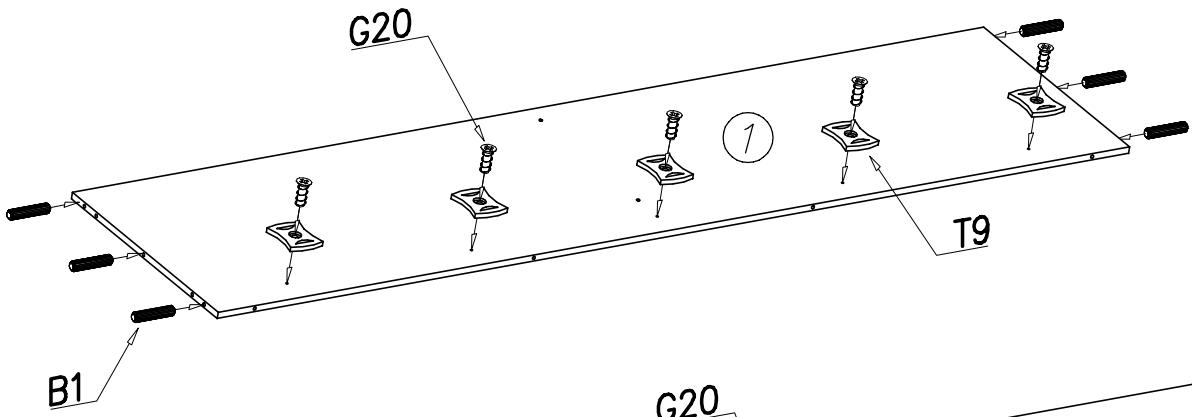
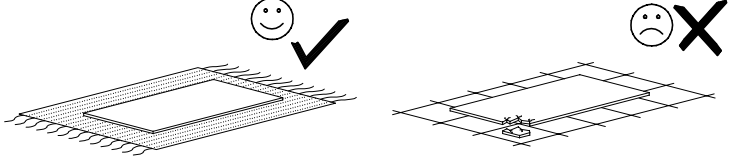

I



<b>B1</b>  ø8x35 x...(12)	<b>T9</b>  x...(10)	<b>G20</b>  5x13 x...(10)
--	--	--

II

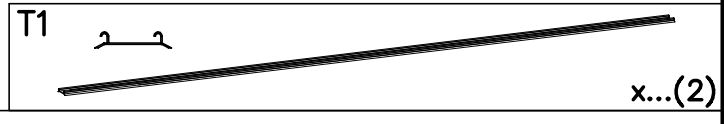
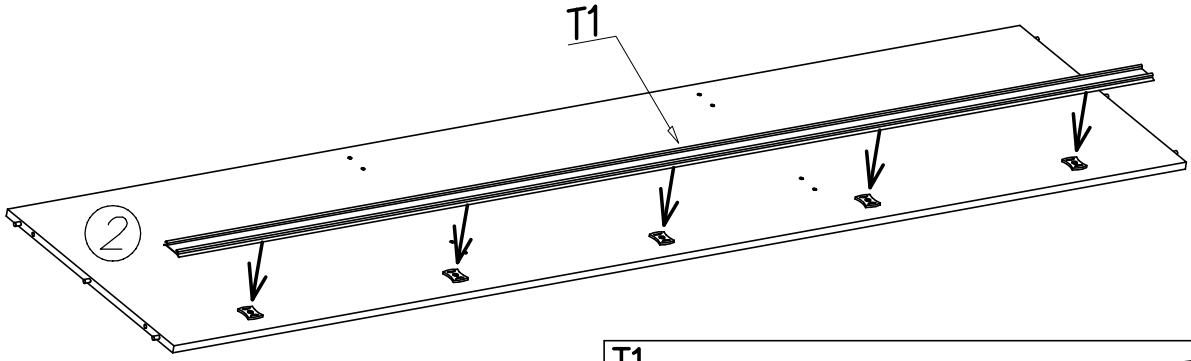
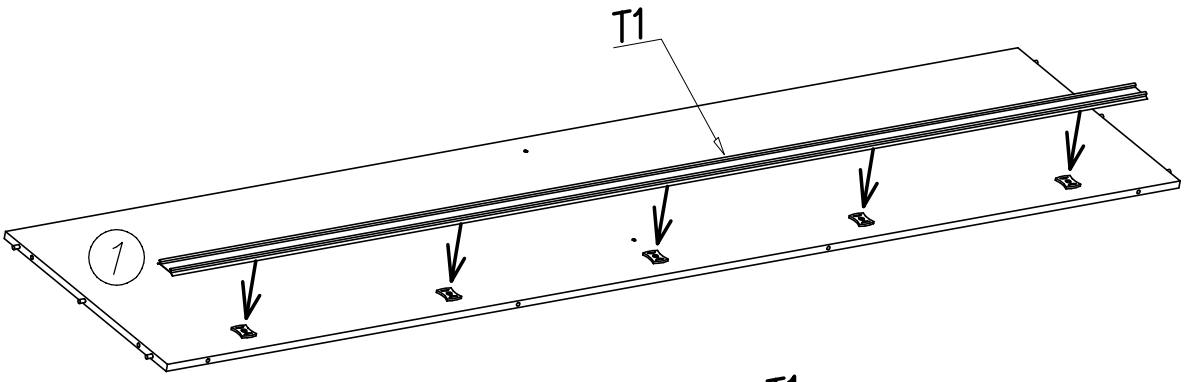
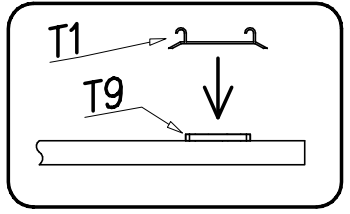



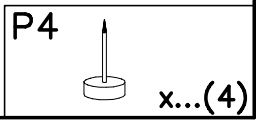
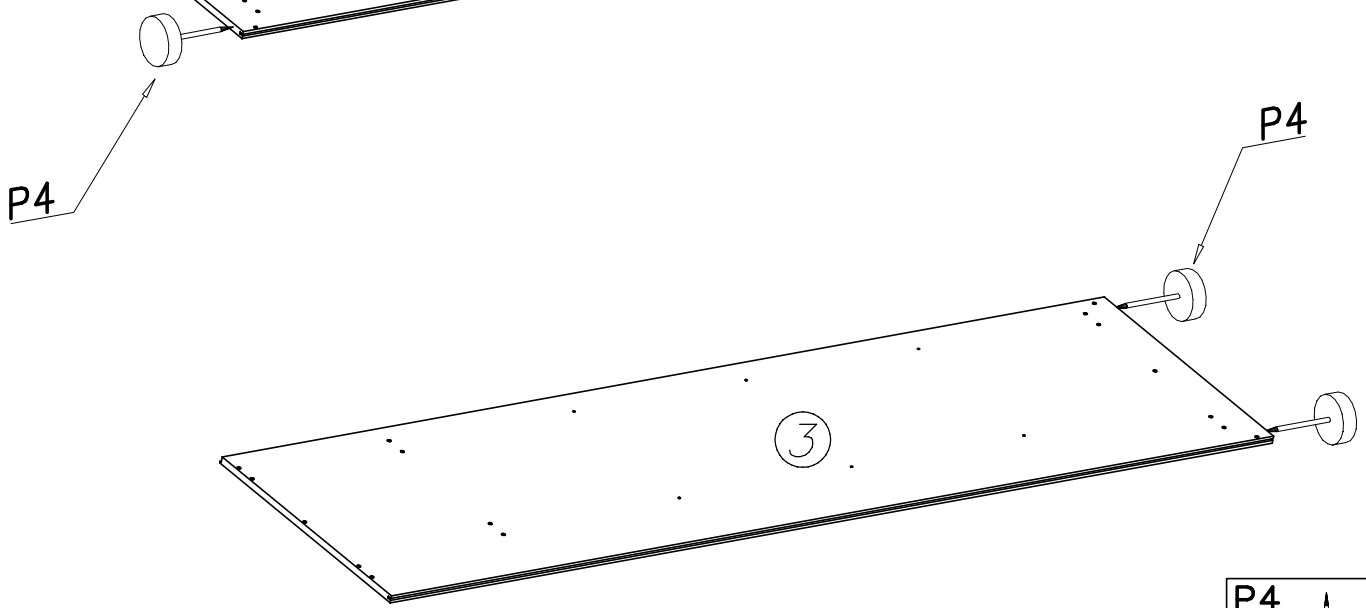
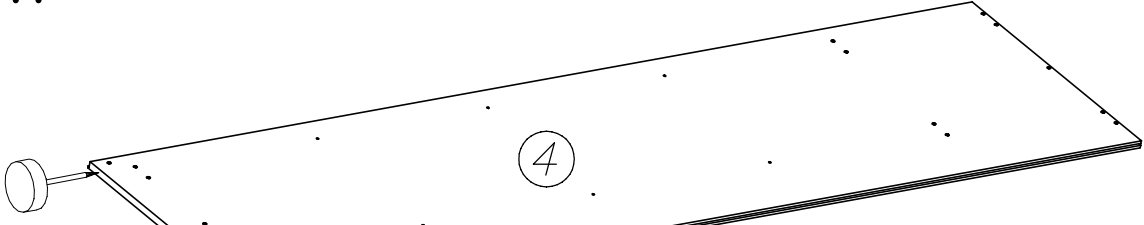

III

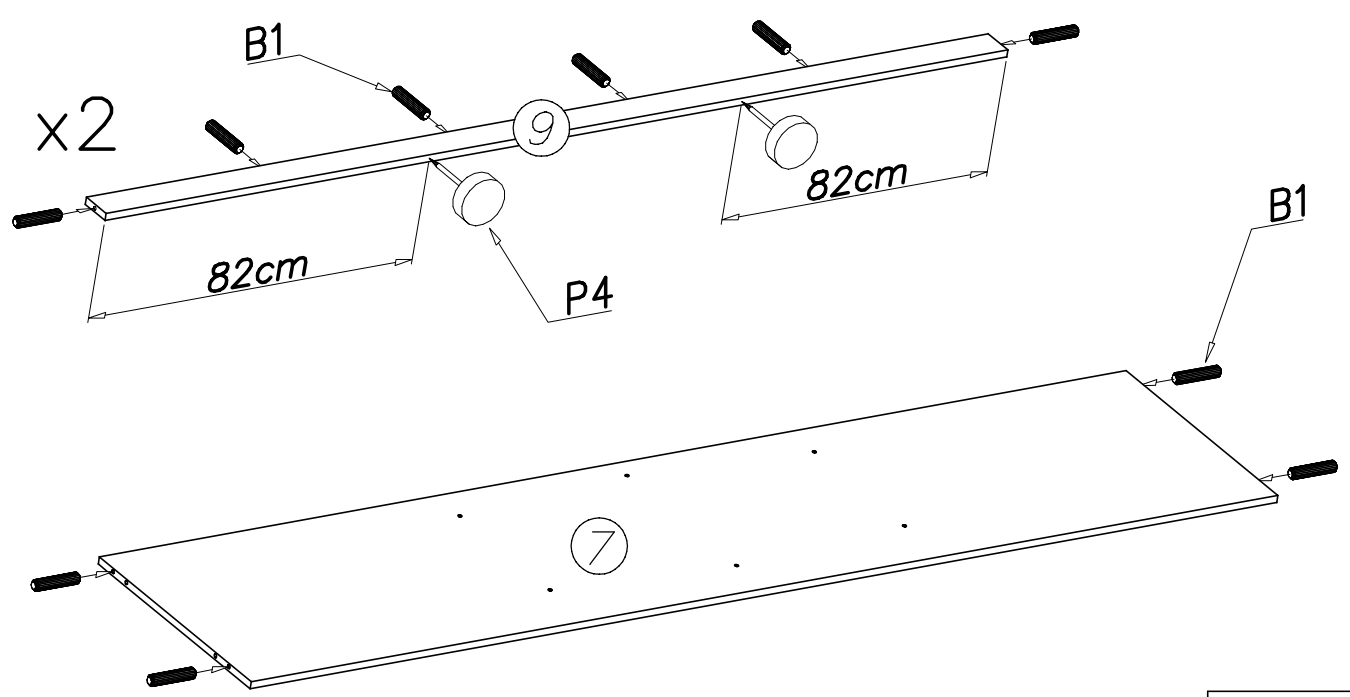
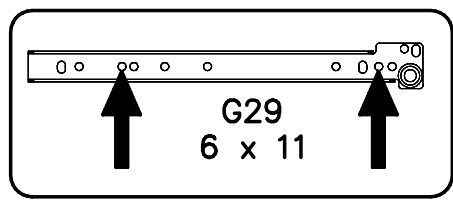
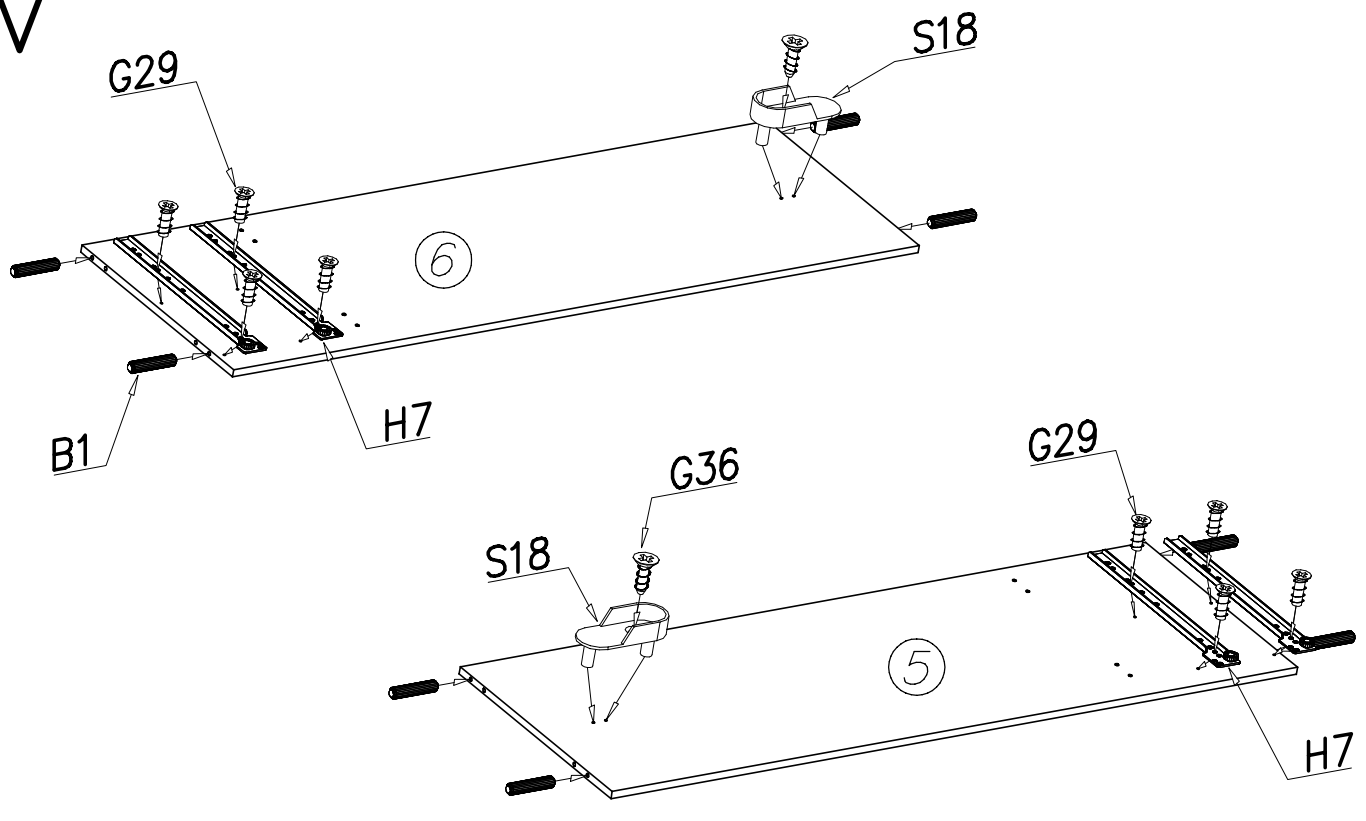

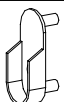

# IV

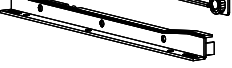

<b>G36</b>  3x13    x...(2)	<b>G29</b>  6x11    x...(8)	<b>S18</b>  x...(2)	<b>B1</b>  ø8x35    x...(24)	<b>H7</b>  x...(2)
--	--	--	---	---

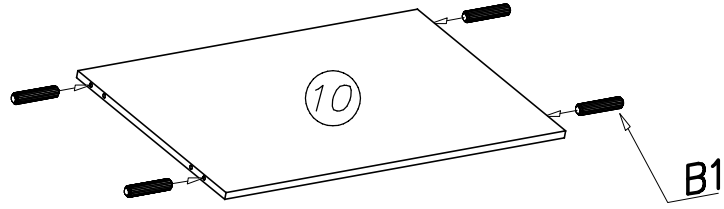
V





B1	
∅8x35	x...(4)

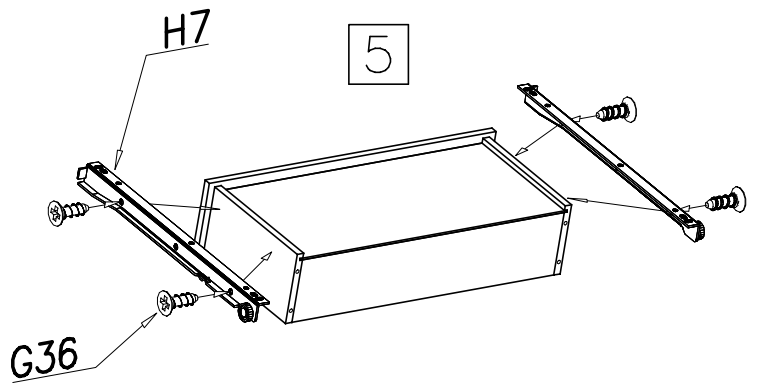
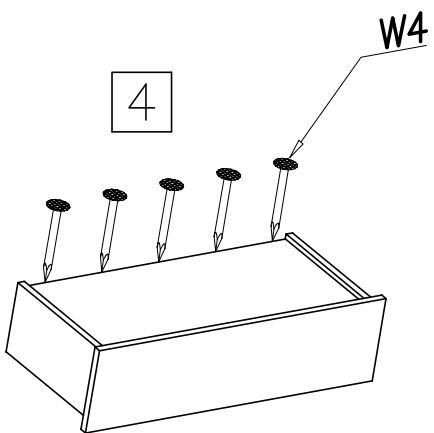
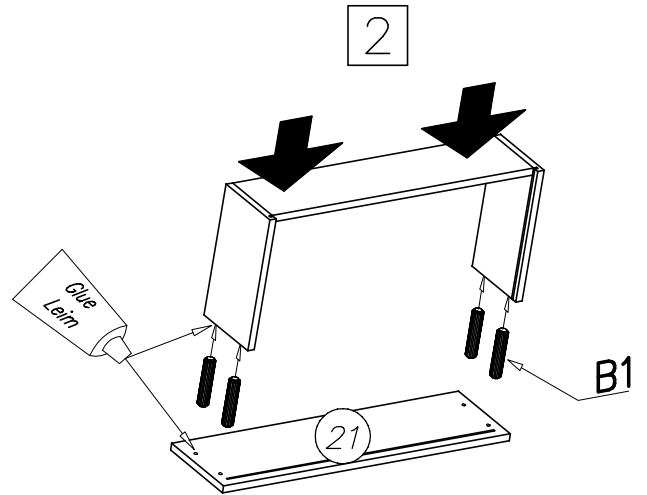
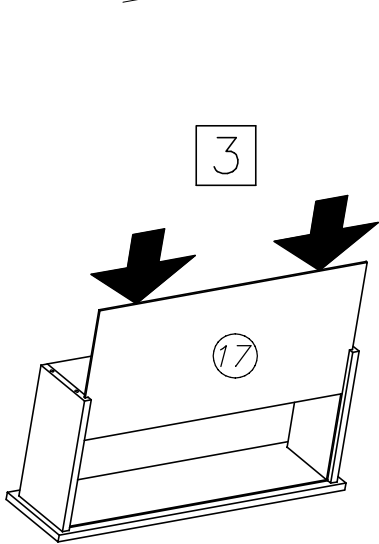
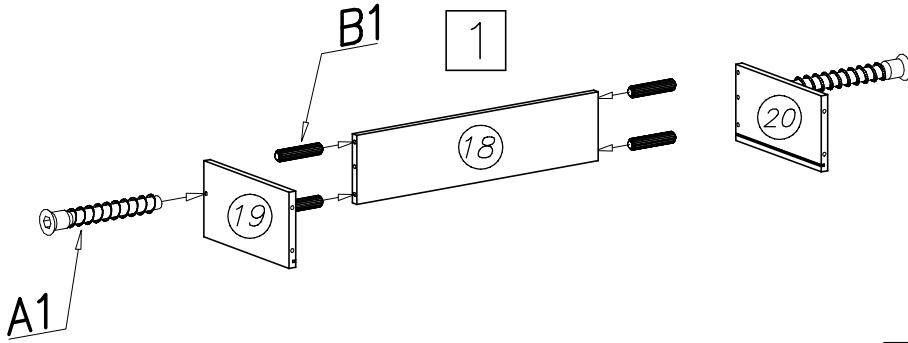

VI x2

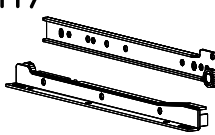

W4	
	x...(12)

H7	
	x...(2)

W1	
	x...(1)
A1	
∅7x50	x...(4)

G36	
3x13	x...(8)
B1	
∅8x35	x...(16)

# VII

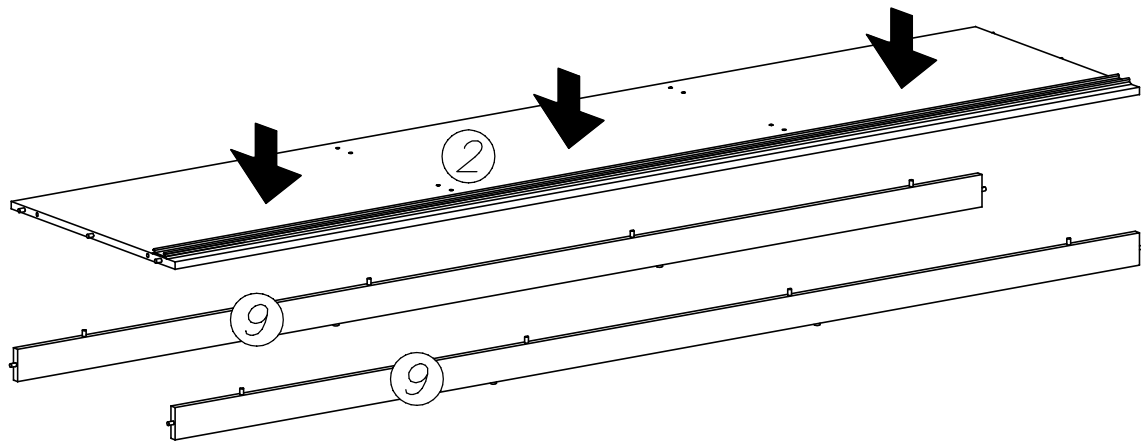

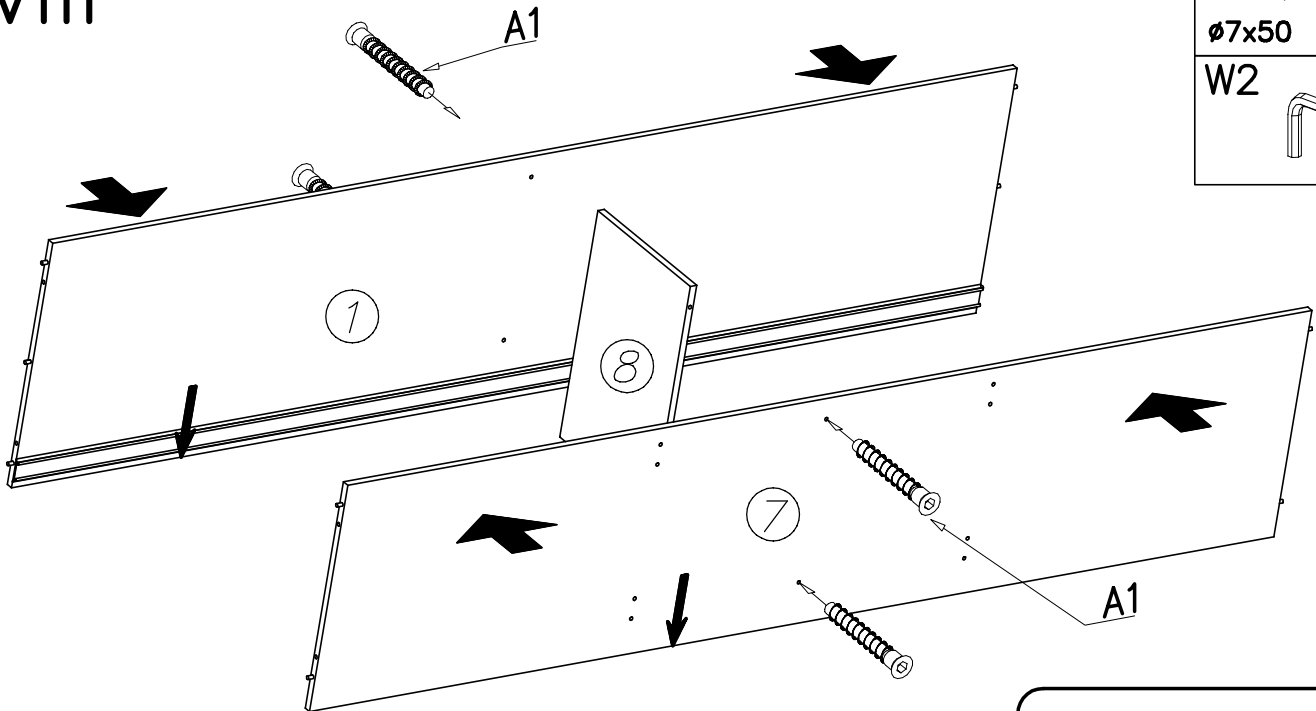

# VIII

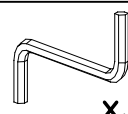

A1		
	ø7x50	x...(4)
W2		
		x...(1)

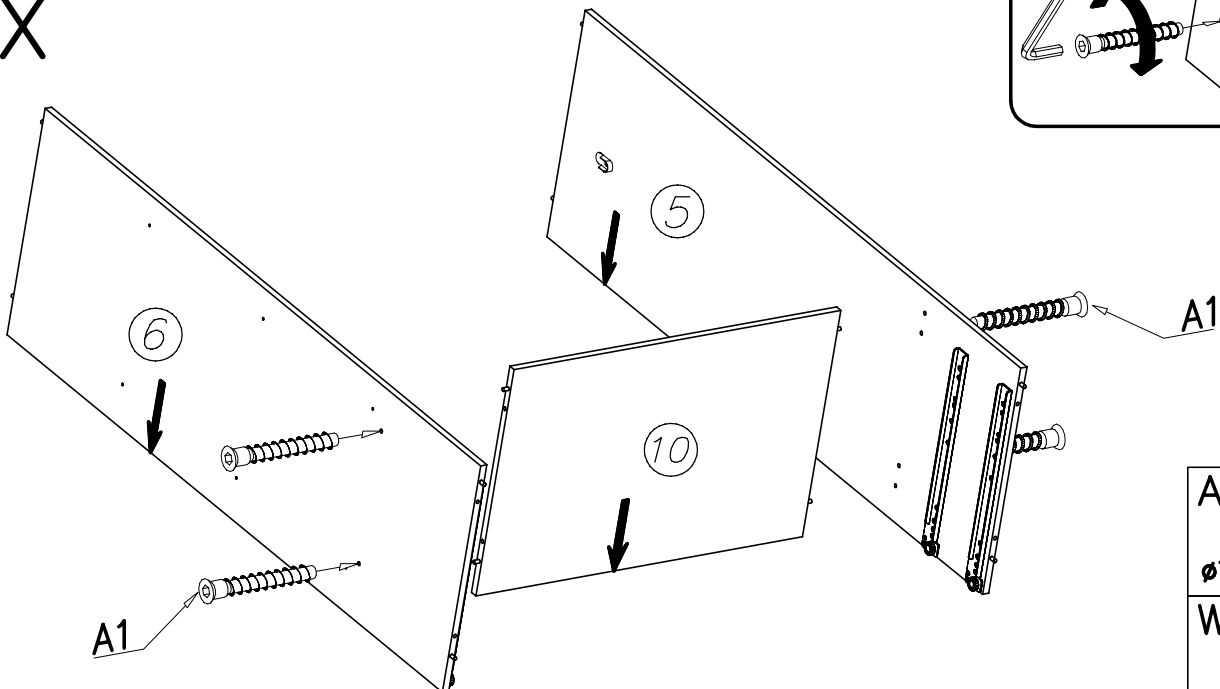

# IX

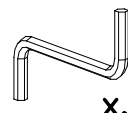

A1		
	ø7x50	x...(4)
W2		
		x...(1)

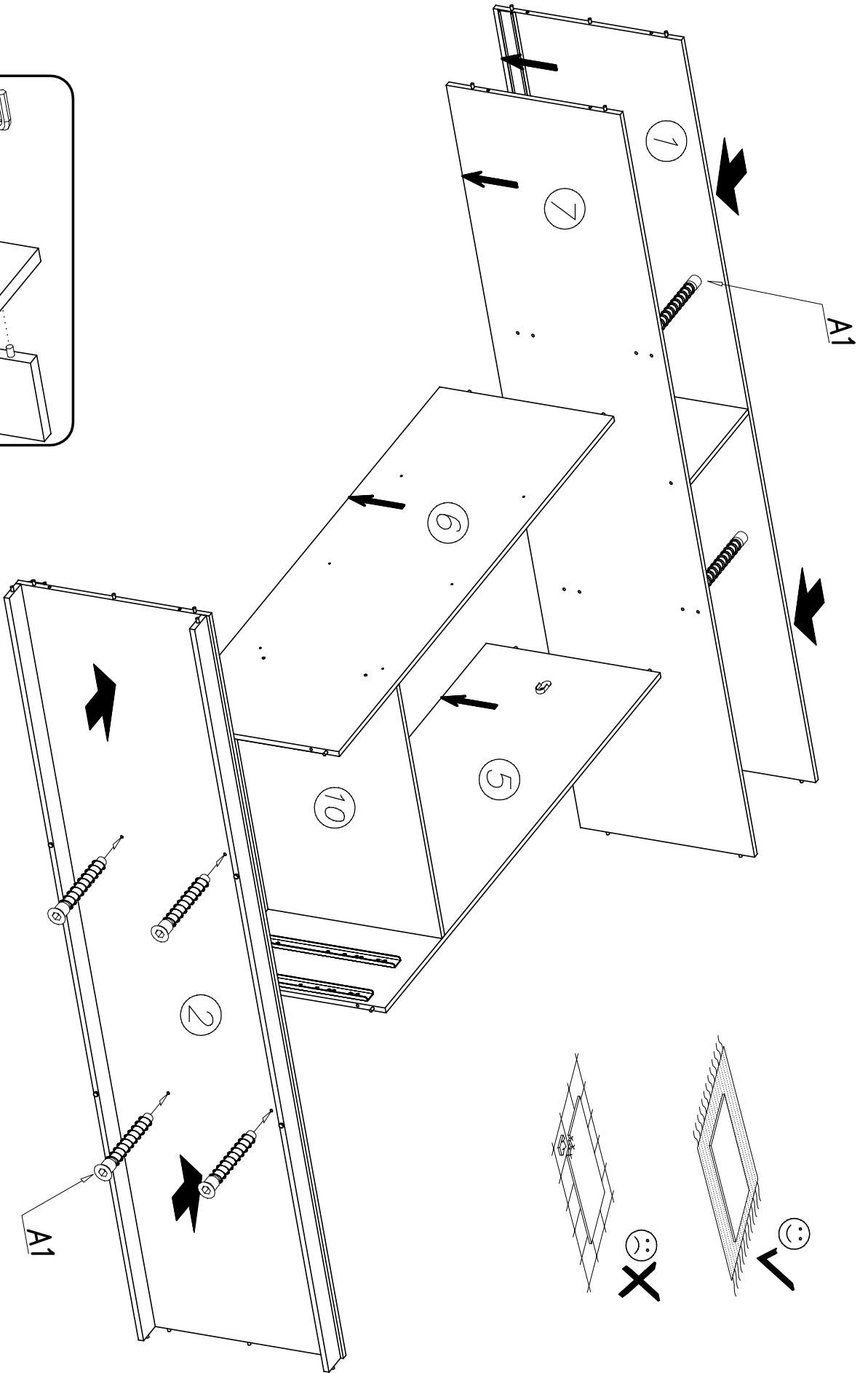
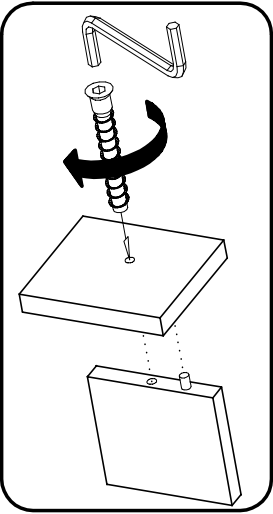

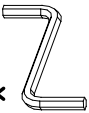
X



 <p>W2 x...(1)</p>	 <p>A1 ø7x50 x...(8)</p>
--	--

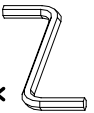

IX

	W2
x...(1)	
	A1
ø7x50	
x...(12)	

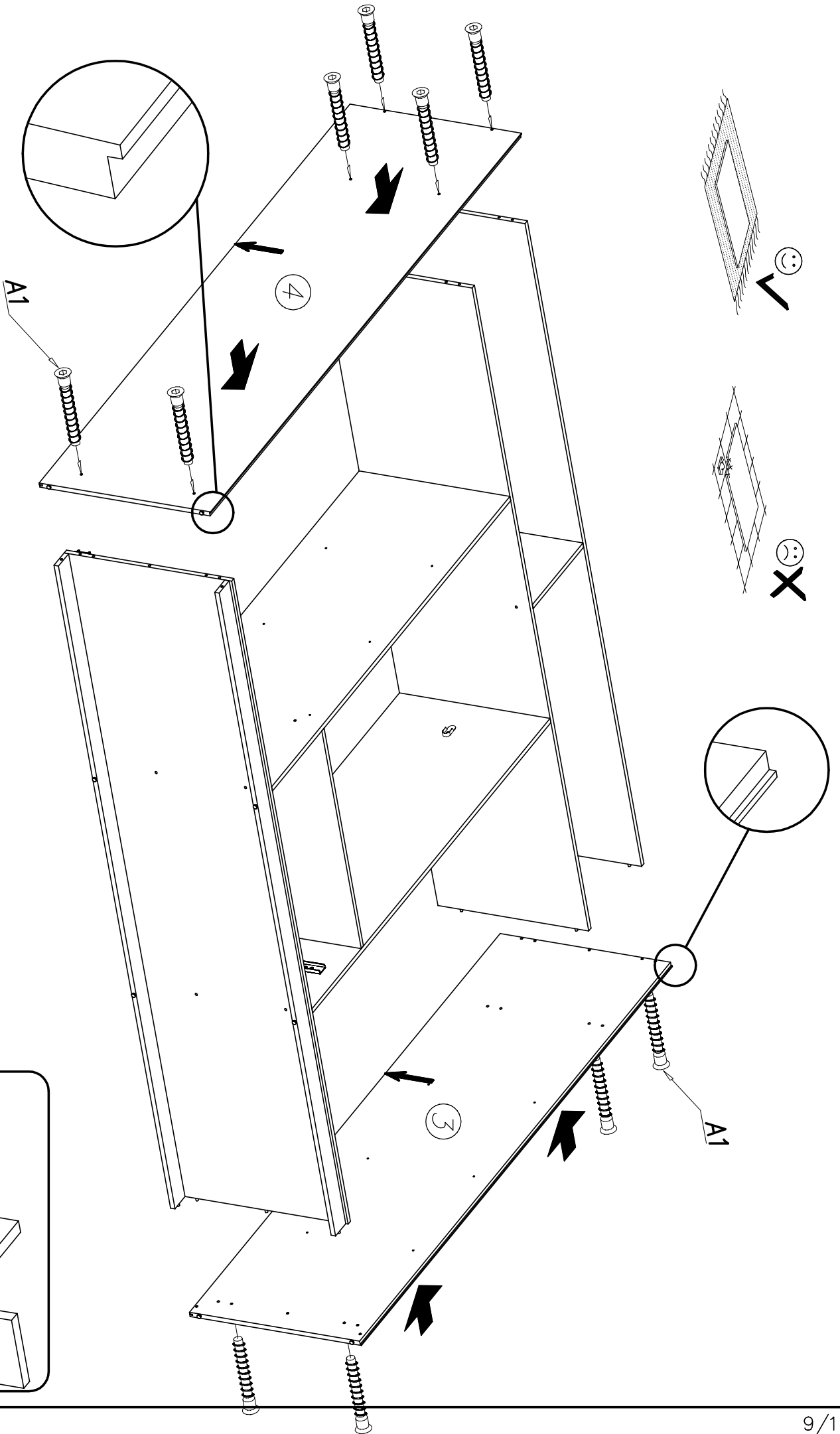
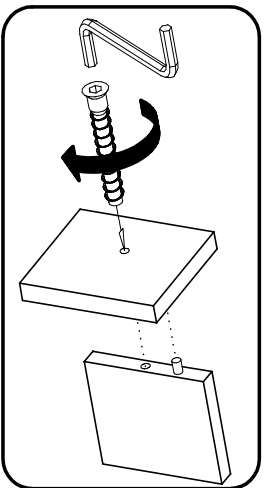

# XII

S17  
x...(32)



S1a  
x...(2)



S1b  
x...(3)



W4  
x...(108)

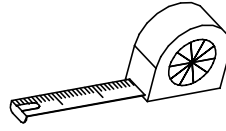
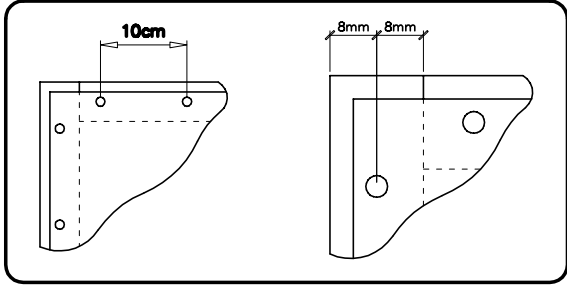

$$a = b$$

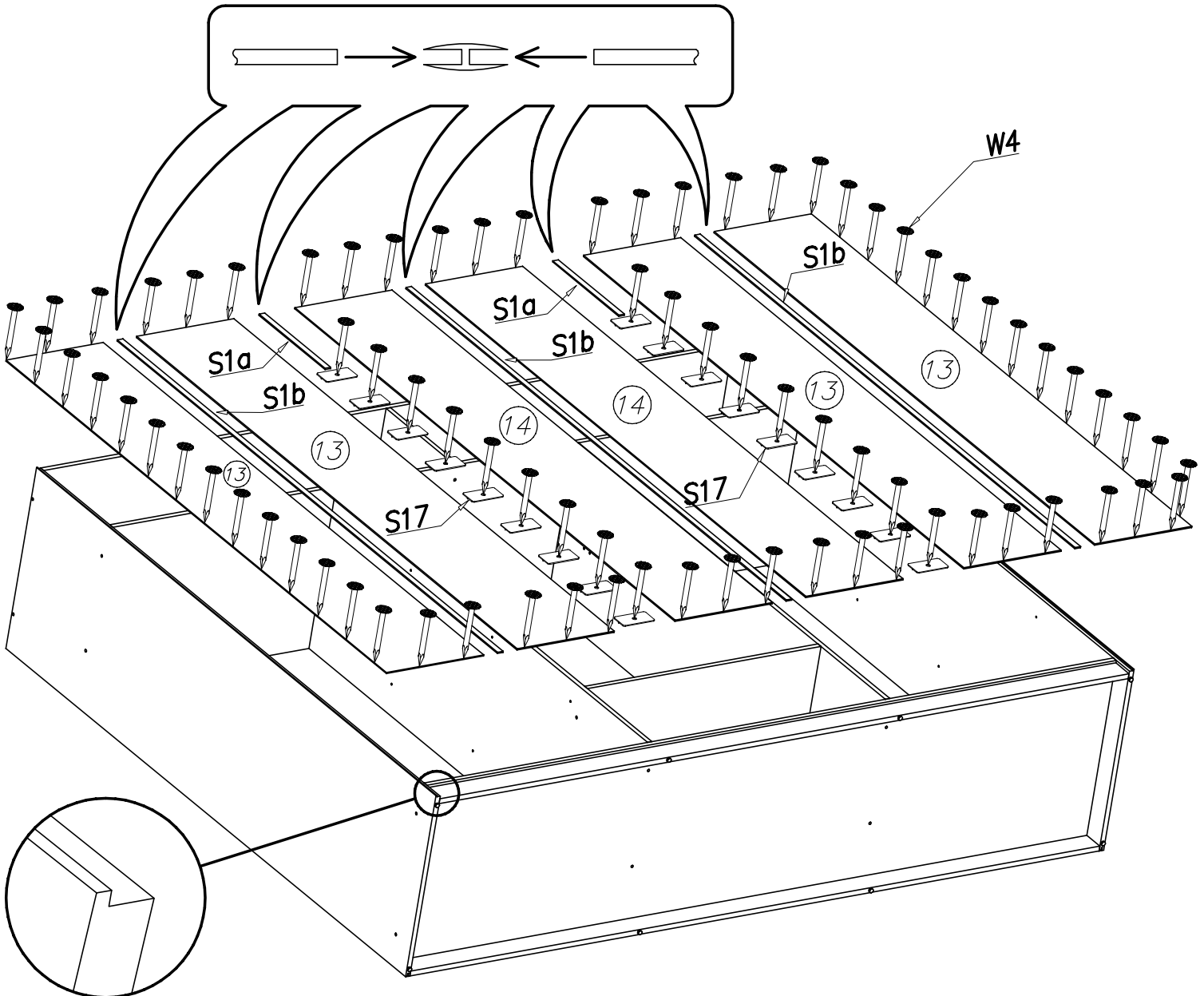
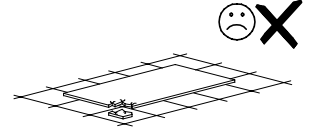
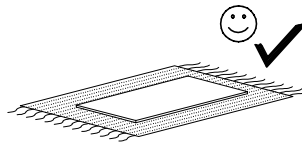
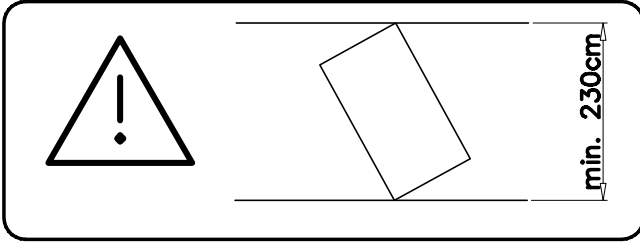
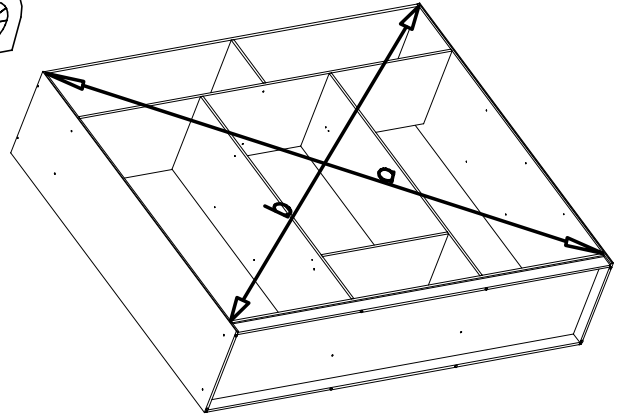

# XIII

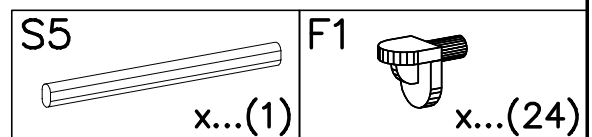
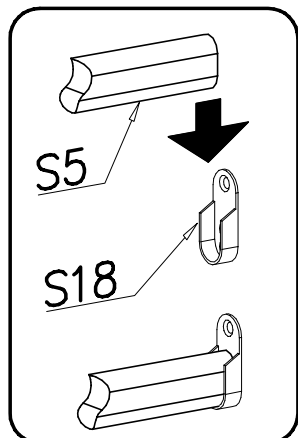
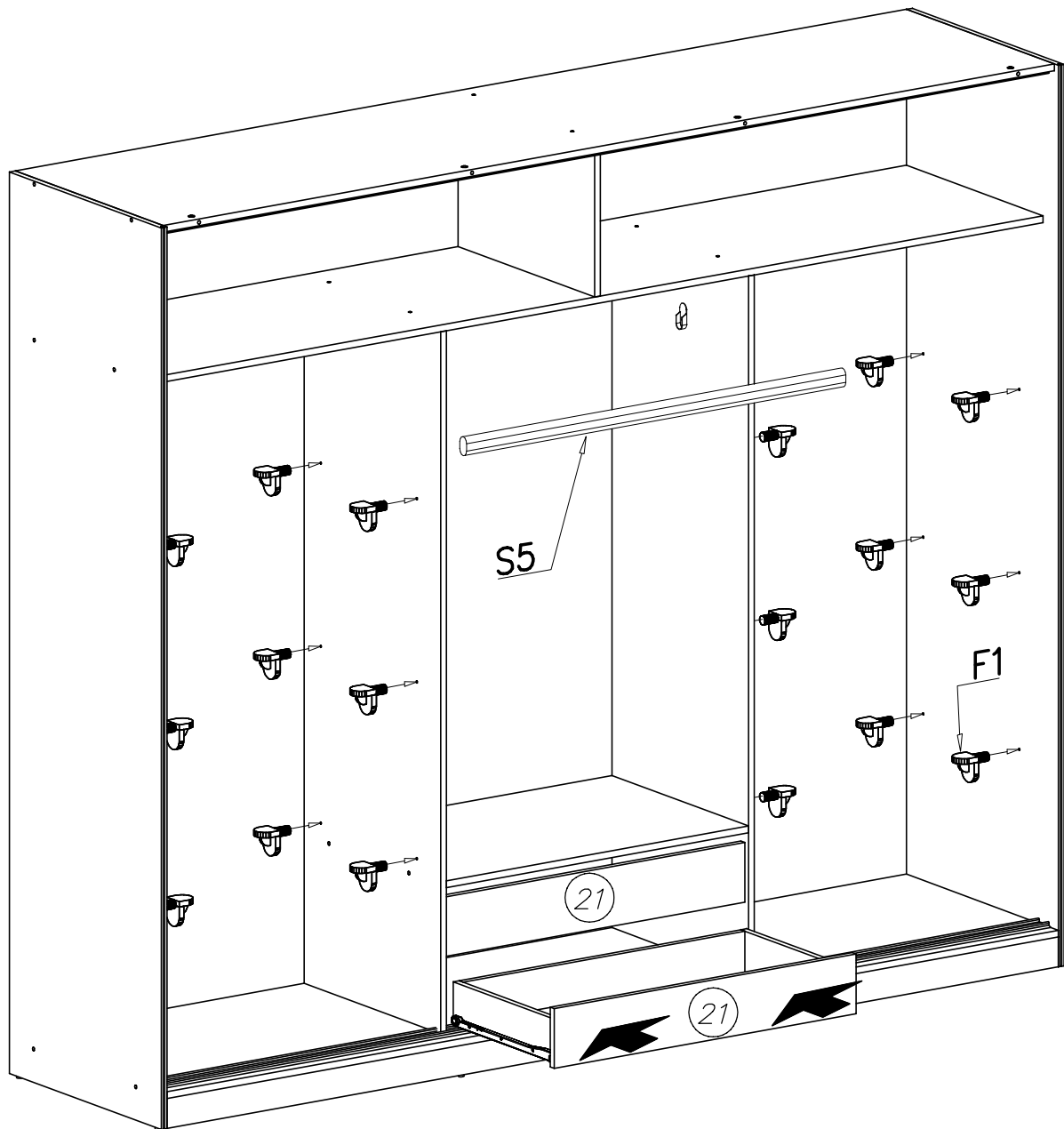

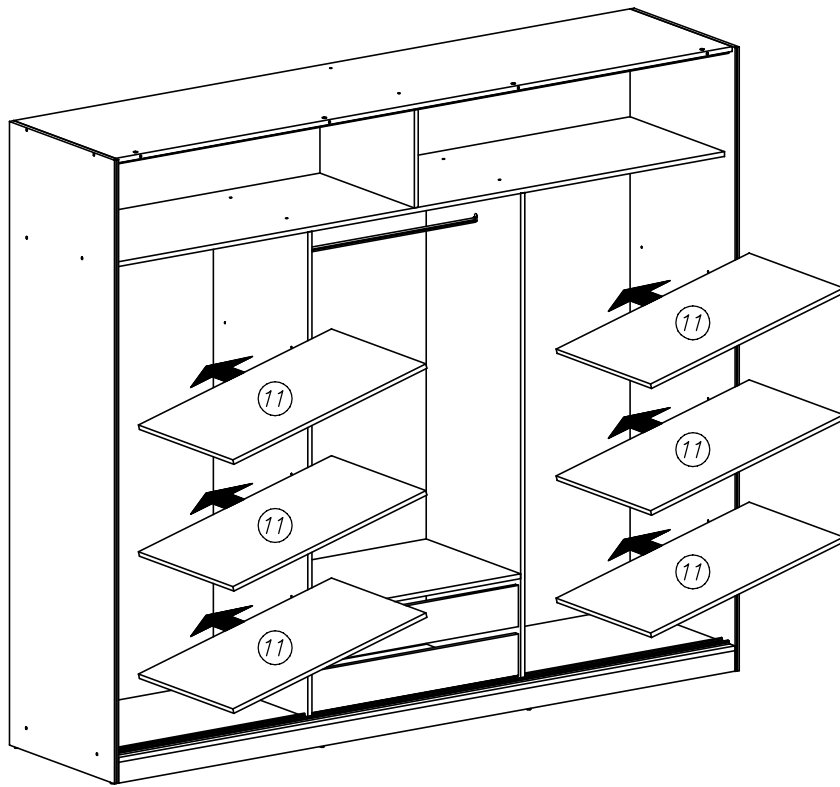

# XIV



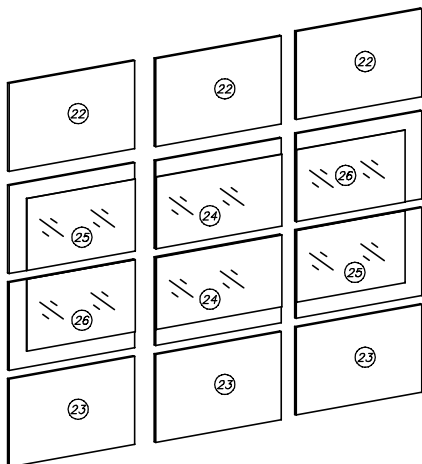
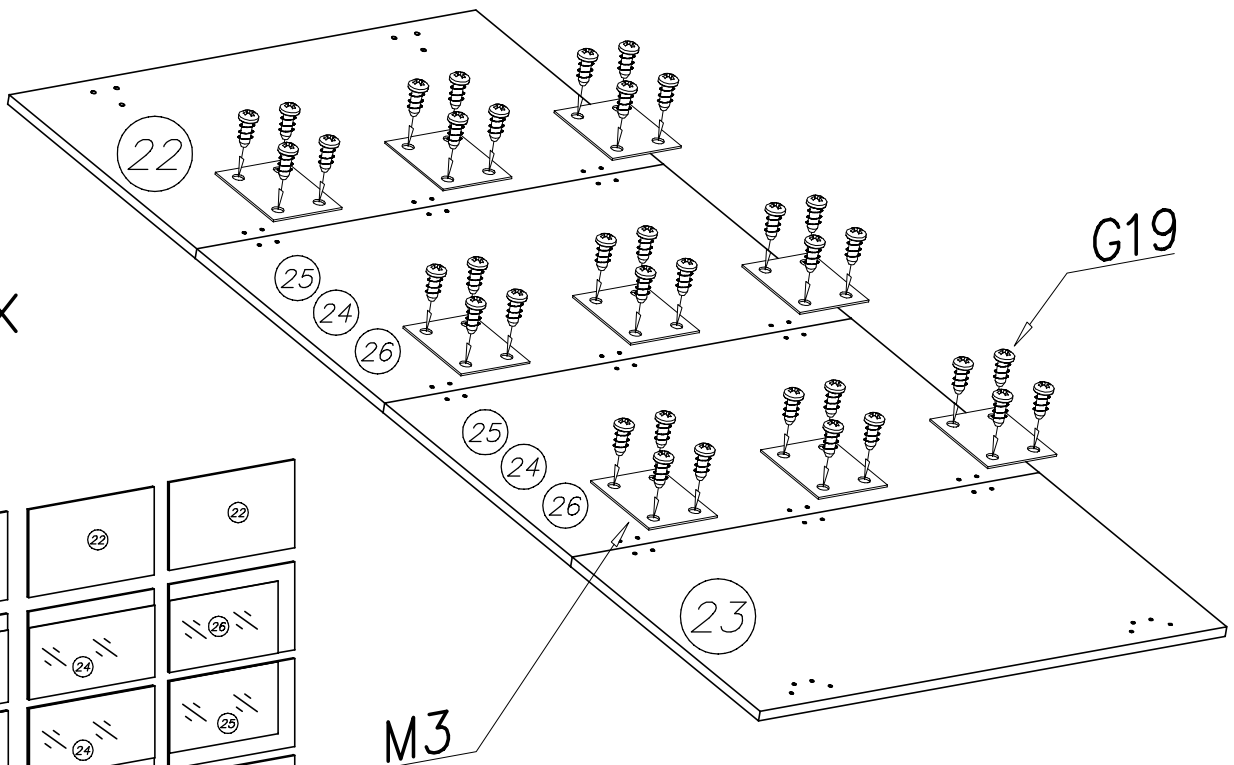
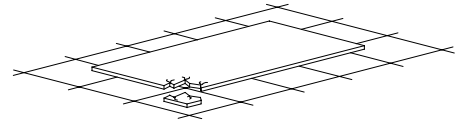
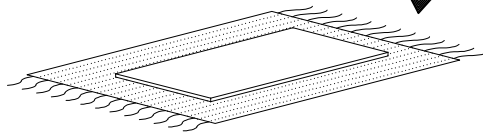

# XV



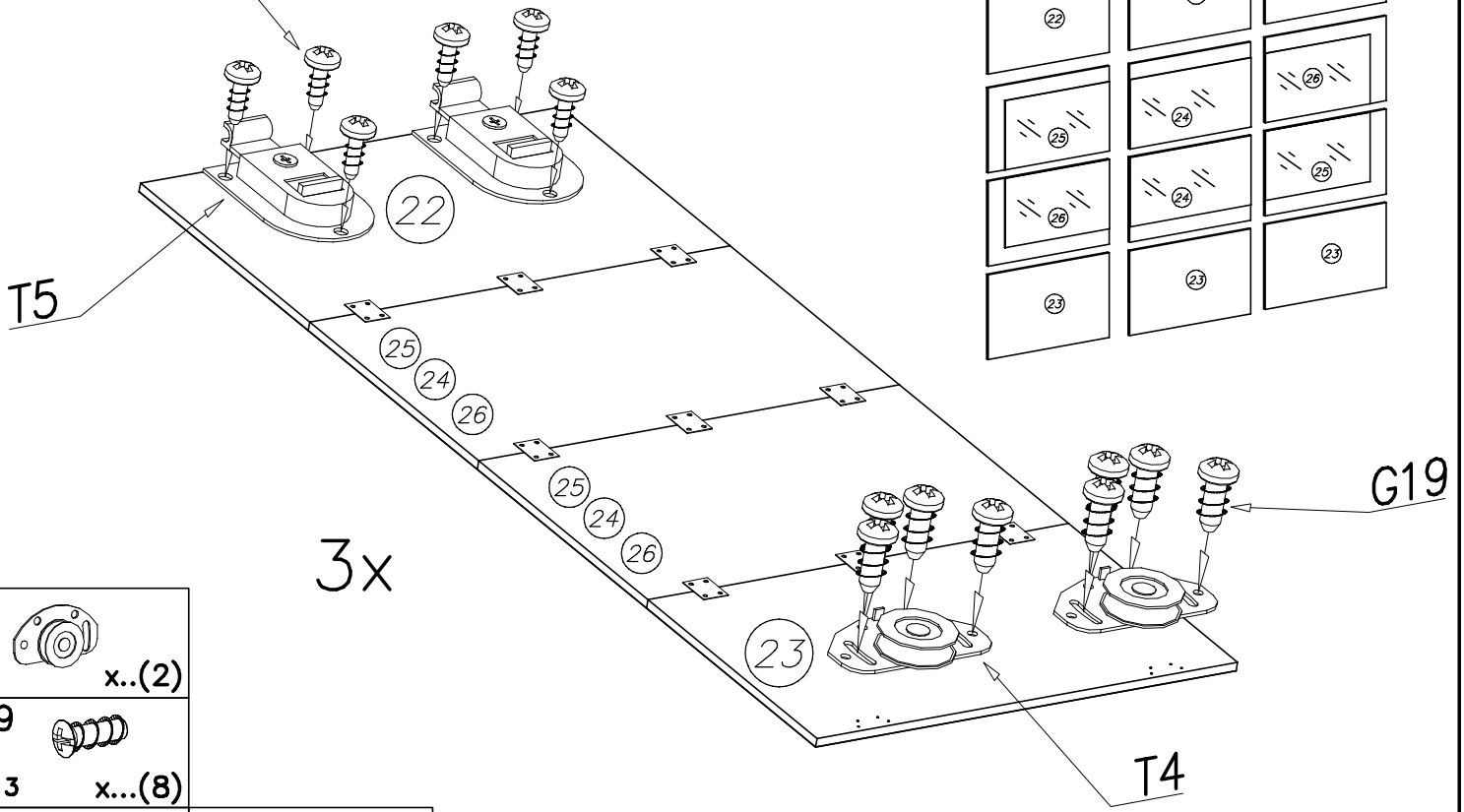

M3		x...(27)	G19		6x13	x...(108)
----	---	----------	-----	---	------	-----------

# XVI G31



T4  x...(2)

G19  6x13 x...(8)

T5  x...(2)

G31  4x13 x...(6)

# XVII

E32  x...(6)

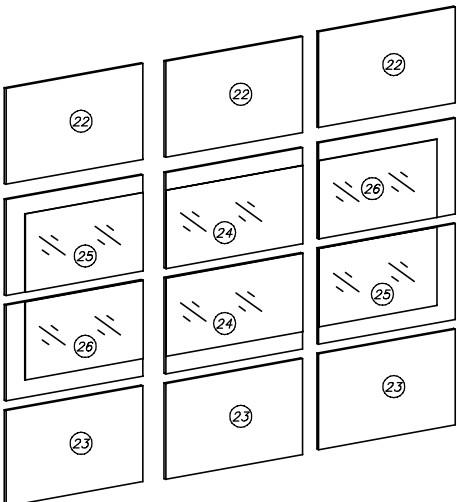
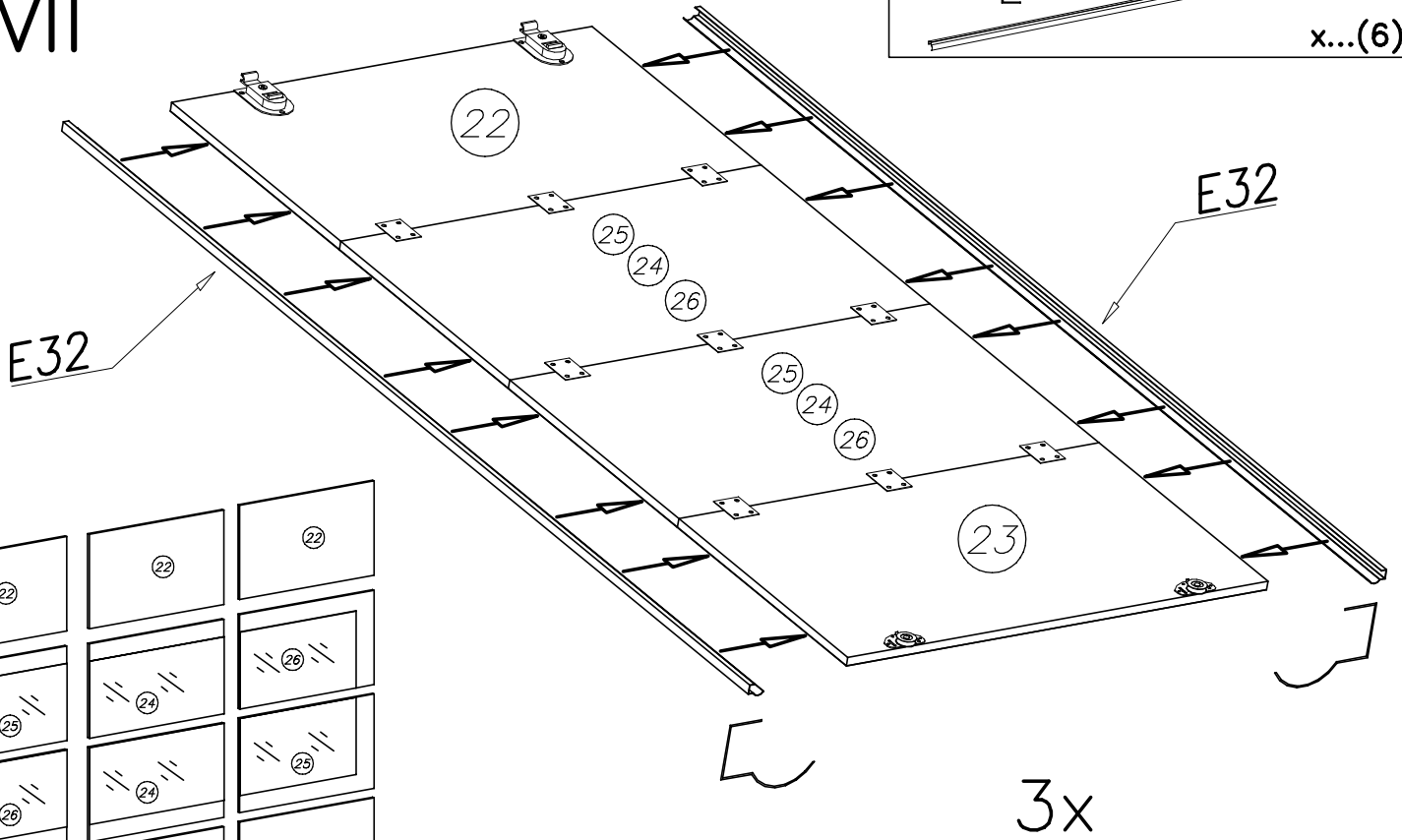

# XVIII

T19  x..(2)

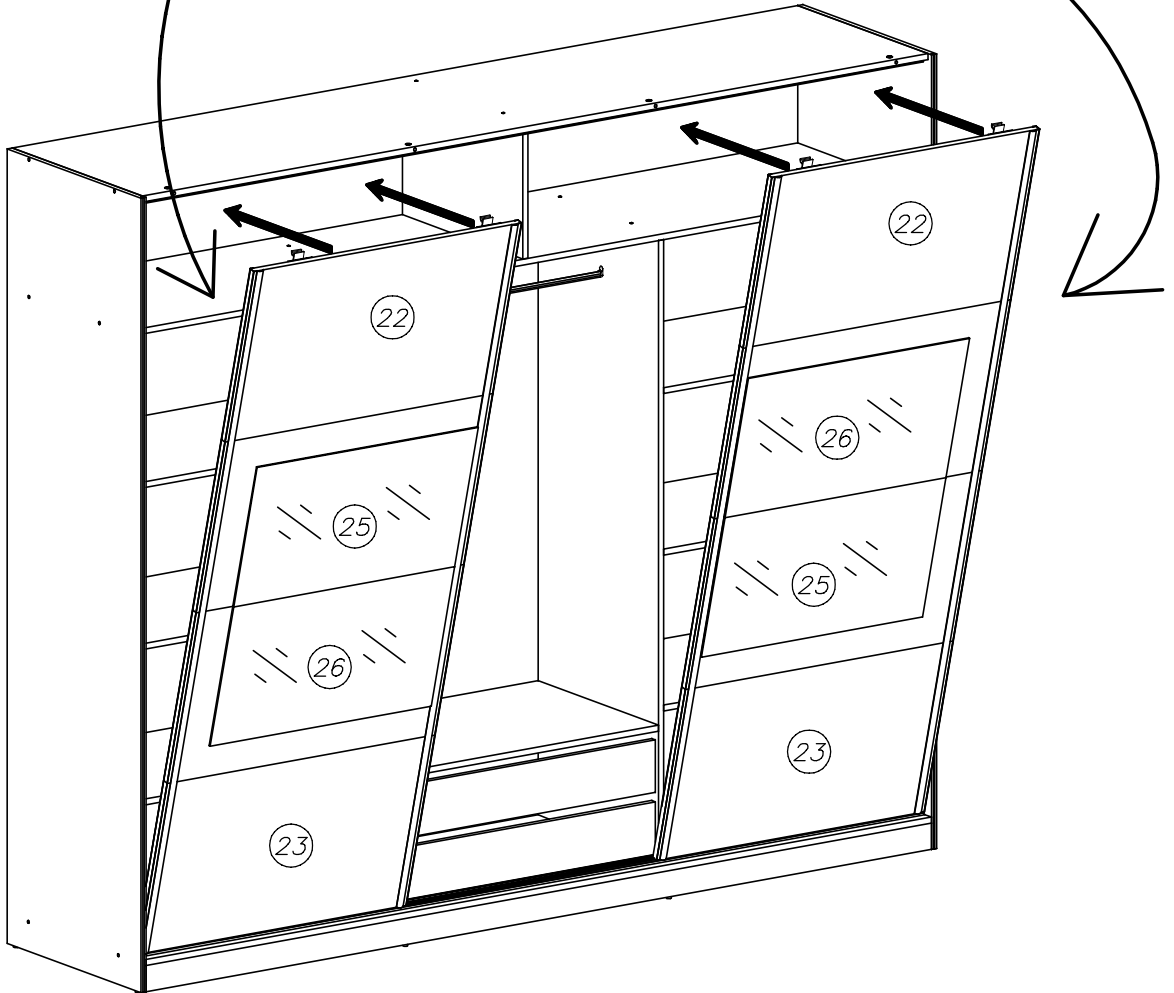
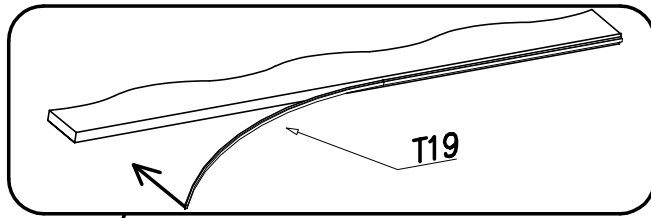

1



2

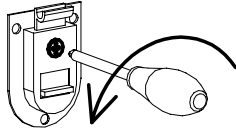

3



4

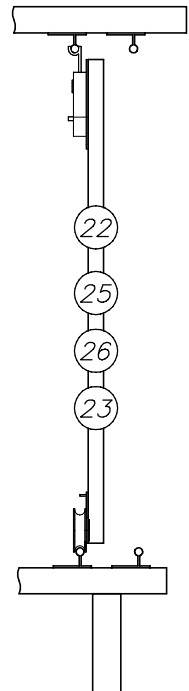
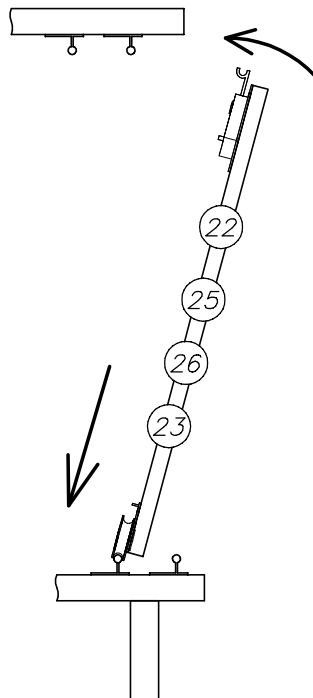
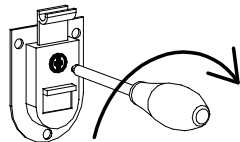

# XIX

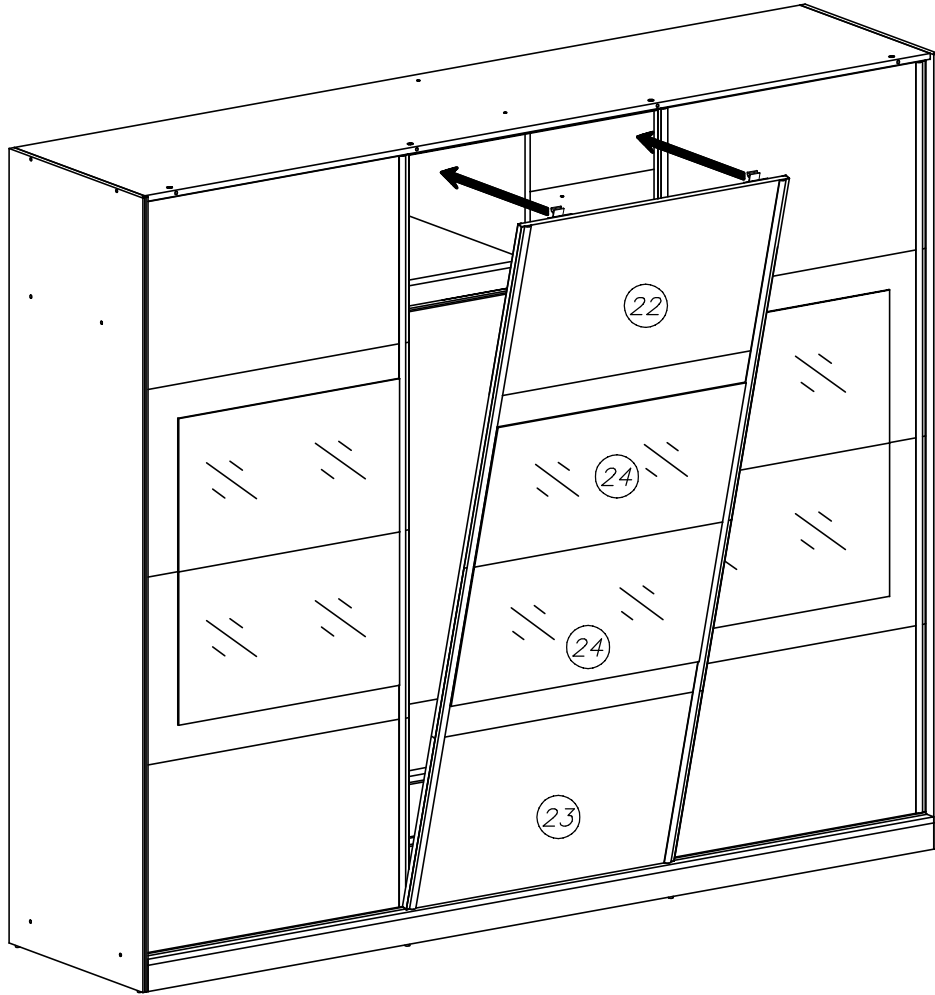

1



2

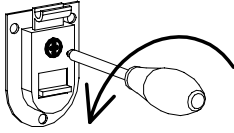

3



4

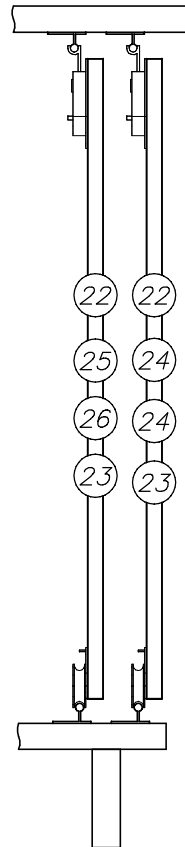
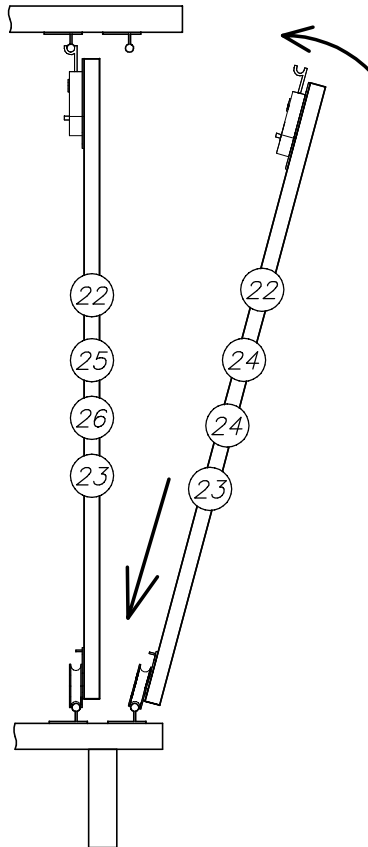
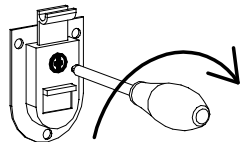

# XX

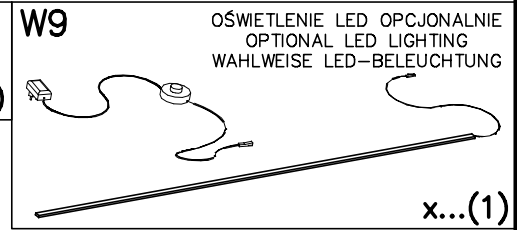
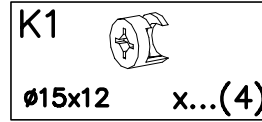
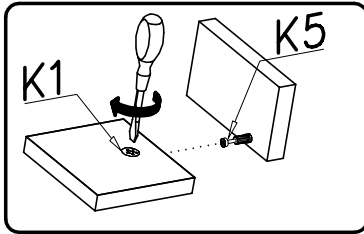
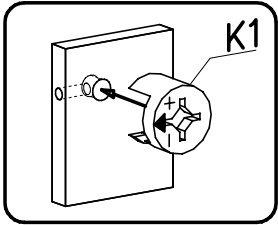
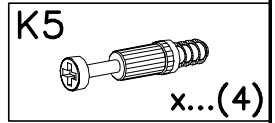
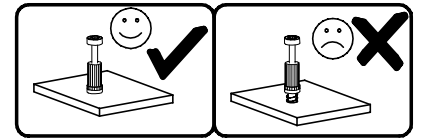
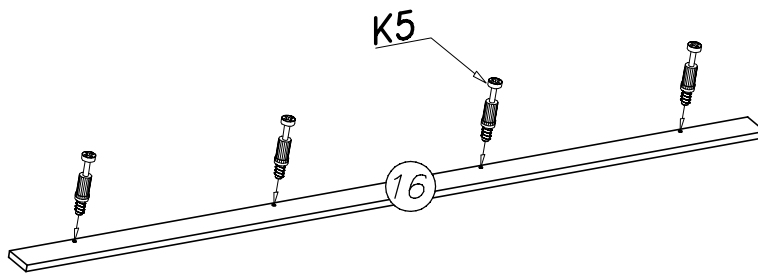

# XXI

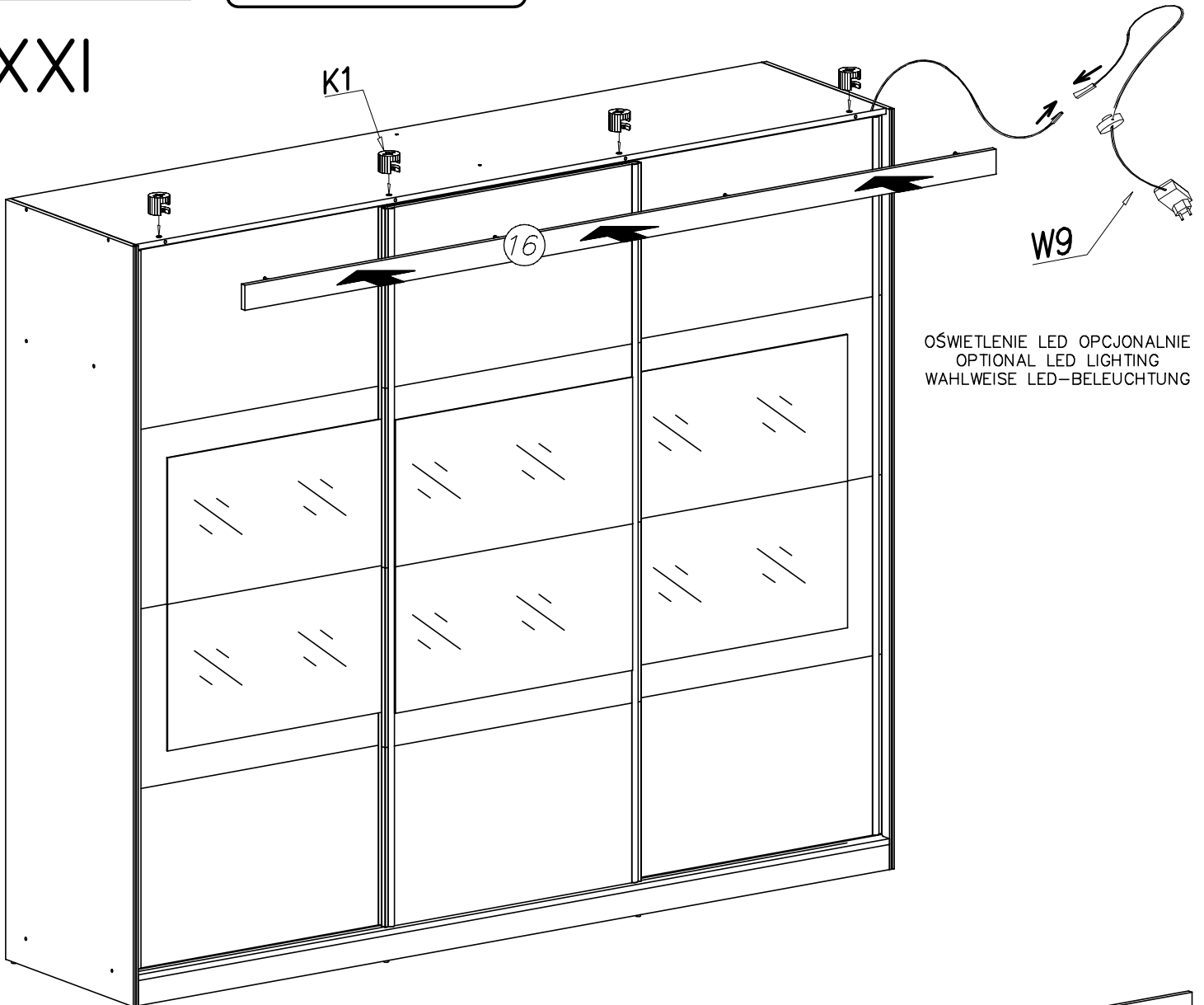

OŚWIETLENIE LED OPCJONALNIE  
OPTIONAL LED LIGHTING  
WAHLWEISE LED-BELEUCHTUNG

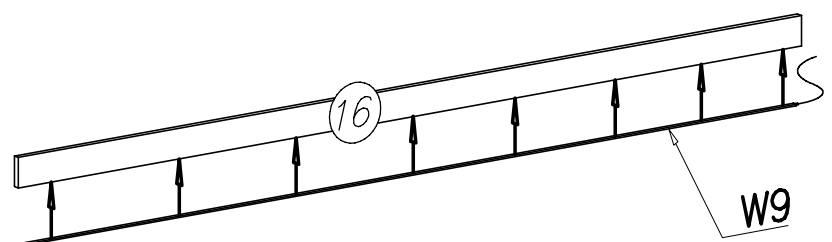

OŚWIETLENIE LED OPCJONALNIE  
OPTIONAL LED LIGHTING  
WAHLWEISE LED-BELEUCHTUNG





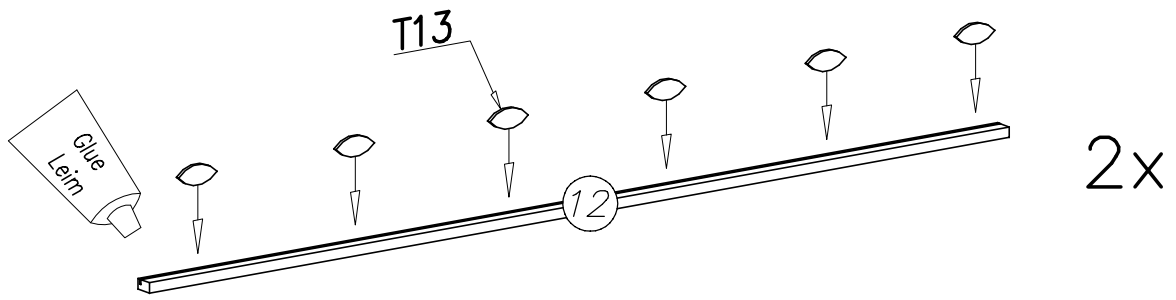

# XXII

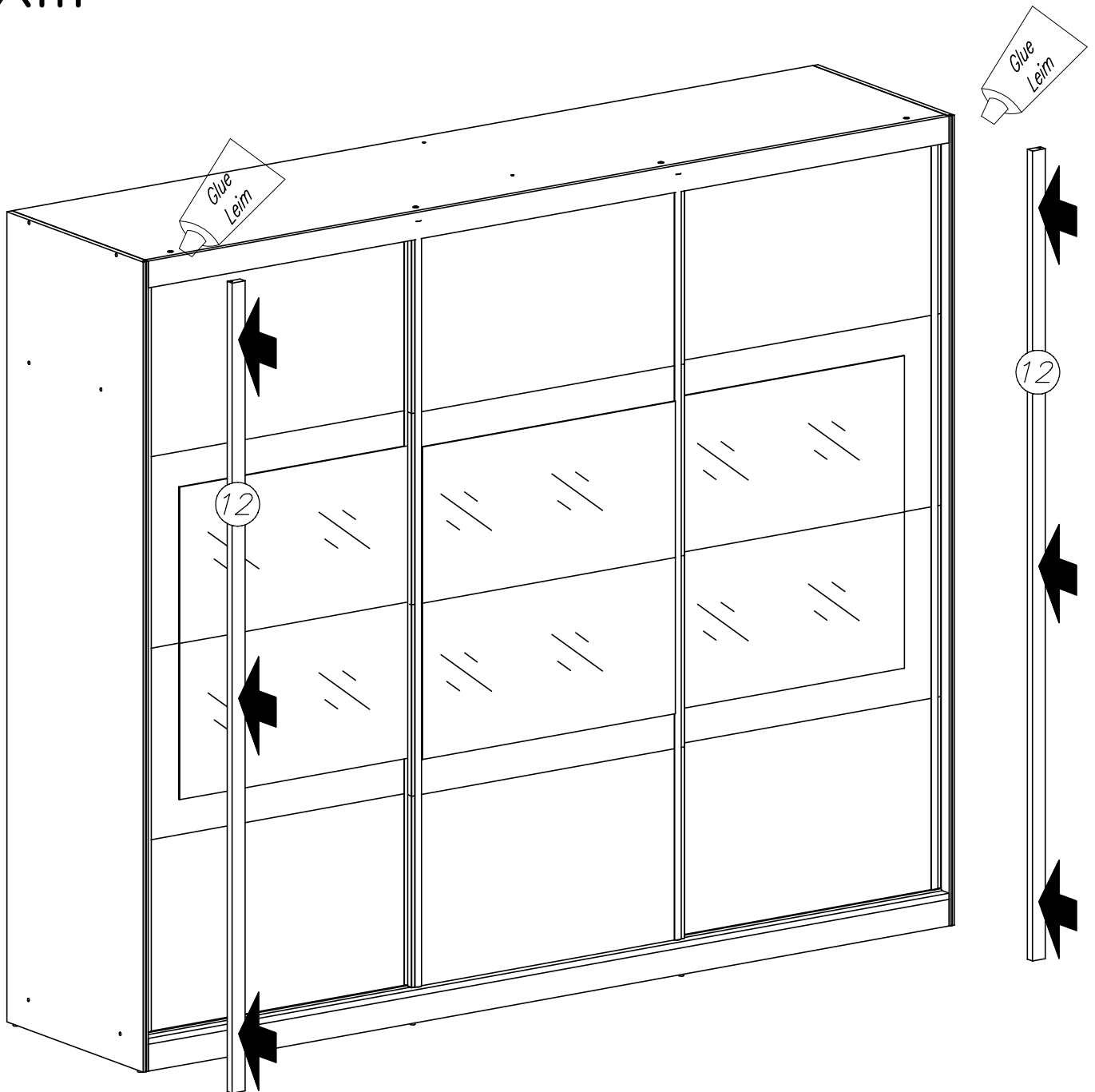

T13		W1	
	x...(12)		x...(1)

# XXIII



W1	
	x...(1)