

# N635P411805/N635P411806

Product manual

Gebrauchsanweisung

Manuel du produit

Manual del producto

Manuale del prodotto

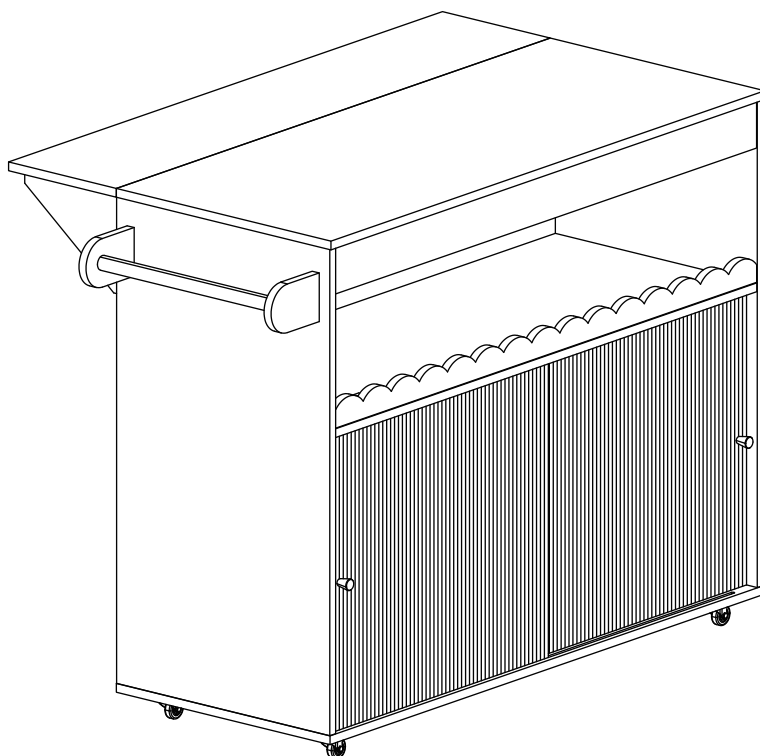

**EN:**Our product will be delivered to you in 2 packages.The delivery times of these 2 packages may differ, please be patient and thank you for your understanding

**FR:**Notre produit vous sera livré en 2 colis.Les délais de livraison de ces 2 colis peuvent différer, soyez patient et merci de votre compréhension.

**DE:**Unser Produkt wird Ihnen in 2 Paketen geliefert.Die Lieferzeiten dieser 2

Paketekönnenabweichen, bitte haben Sie etwas Geduld und vielen Dank für Ihr Verständnis

**IT:**I nostri prodotti vengono trasportati in due pacchetti. I tempi di consegna dei due pacchetti sono diversi abbiate pazienza e vi ringrazio per la vostra comprensione.

**ES:**Nuestro producto se entrega en dos paquetes. El tiempo de entrega de estos dos paquetes es diferente. Por favor sea paciente. Gracias por su comprensión.

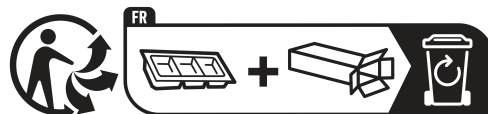

2PERS



60 MIN

Tool Required Not Provided





[DE]

**Warnung:** Lesen Sie die Anleitung vor dem Zusammenbau bitte vollständig durch. Überprüfen Sie, ob Sie alle auf den Seiten aufgeführten Komponenten und Werkzeuge haben.

**Warnung:** Legen Sie alle Teile auf eine ebene Fläche. Legen Sie eine weiche Decke oder Ähnliches darunter, um sie vor Kratzern oder Flecken zu schützen. Vermeiden Sie es, Komponenten über den Boden zu ziehen oder zu schieben.

**Warnung:** Überprüfen Sie regelmäßig alle Beschläge und Befestigungen, um sicherzustellen, dass sie sicher sind und um Unfälle zu vermeiden. Wenn Teile fehlen, kaputt, beschädigt oder abgenutzt sind, verwenden Sie das Produkt nicht weiter, bis es mit vom Hersteller autorisierten Teilen repariert wurde.

**Warnung:** Lassen Sie Kinder nicht auf die Möbel klettern, da dies zum Umkippen und zu schweren Verletzungen führen kann. Bauen Sie die Möbel außerhalb der Reichweite von Kindern zusammen.

**Warnung:** Stellen Sie die Möbel nicht in die Nähe von Feuerquellen oder heißen Gegenständen, um Brandgefahr zu vermeiden.

**Warnung:** Reinigen Sie die Möbel mit einem feuchten Tuch oder Alkohol. Verwenden Sie keine Reinigungsmittel mit ätzenden Chemikalien.

[EN]

**Warning:** Please read instructions fully before starting assembly. Check you have all the components and tools listed on pages.

**Warning:** Please place all parts on a flat surface. Place a soft blanket or similar underneath to protect against scratches or stains. Avoid dragging or sliding components across the floor.

**Warning:** Regularly check all fittings and fastenings to ensure they are secure and to prevent accidents. If any parts are missing, broken, damaged, or worn, discontinue use of the product until repairs have been made using factory authorized parts.

**Warning:** Do not allow children to climb on the furniture as this may result in tipping and serious personal injury. Assemble the furniture away from the reach of children.

**Warning:** Do not place furniture close to fire sources or high-temperature objects to avoid the risk of fire.

**Warning:** Clean furniture with a damp cloth or alcohol, avoid using cleaning agents containing corrosive chemicals.

[FR]

**Avertissement :** Veuillez lire entièrement les instructions avant de commencer l'assemblage. Vérifiez que vous disposez de tous les composants et outils répertoriés sur les pages.

**Avertissement :** Veuillez placer toutes les pièces sur une surface plane. Placez une couverture douce ou similaire en dessous pour les protéger des rayures ou des taches. Évitez de faire glisser les composants sur le sol.

**Avertissement :** Vérifiez régulièrement tous les raccords et fixations pour vous assurer qu'ils sont bien fixés et pour éviter les accidents. Si des pièces manquent, sont cassées, endommagées ou usées, cessez d'utiliser le produit jusqu'à ce que des réparations aient été effectuées à l'aide de pièces autorisées par l'usine.

**Avertissement :** Ne laissez pas les enfants grimper sur les meubles car cela pourrait entraîner un basculement et des blessures graves. Assemblez les meubles hors de portée des enfants.

**Avertissement :** Ne placez pas les meubles à proximité de sources de feu ou d'objets à haute température pour éviter tout risque d'incendie.

**Avertissement :** Nettoyez les meubles avec un chiffon humide ou de l'alcool, évitez d'utiliser des produits de nettoyage contenant des produits chimiques corrosifs.



[IT]

**Attenzione:** leggere attentamente le istruzioni prima di iniziare il montaggio. Verificare di avere tutti i componenti e gli strumenti elencati nelle pagine.

**Attenzione:** posizionare tutte le parti su una superficie piana. Posizionare una coperta morbida o simile sotto per proteggere da graffi o macchie. Evitare di trascinare o far scivolare i componenti sul pavimento.

**Attenzione:** controllare regolarmente tutti i raccordi e i dispositivi di fissaggio per assicurarsi che siano sicuri e per prevenire incidenti. Se alcune parti sono mancanti, rotte, danneggiate o usurate, interrompere l'uso del prodotto fino a quando non siano state eseguite le riparazioni utilizzando parti autorizzate dalla fabbrica.

**Attenzione:** non consentire ai bambini di arrampicarsi sui mobili poiché ciò potrebbe causare ribaltamenti e gravi lesioni personali. Montare i mobili lontano dalla portata dei bambini.

**Attenzione:** non posizionare i mobili vicino a fonti di fuoco o oggetti ad alta temperatura per evitare il rischio di incendio.

**Attenzione:** pulire i mobili con un panno umido o alcol, evitare di utilizzare detergenti contenenti sostanze chimiche corrosive.

[ES]

**Advertencia:** Lea las instrucciones completamente antes de comenzar el montaje. Compruebe que tiene todos los componentes y herramientas que se enumeran en las páginas.

**Advertencia:** Coloque todas las piezas sobre una superficie plana. Coloque una manta suave o algo similar debajo para protegerlas de rayones o manchas. Evite arrastrar o deslizar los componentes por el piso.

**Advertencia:** Verifique regularmente todos los accesorios y fijaciones para asegurarse de que estén seguros y evitar accidentes. Si falta alguna pieza, está rota, dañada o desgastada, deje de usar el producto hasta que se hayan realizado las reparaciones con piezas autorizadas de fábrica.

**Advertencia:** No permita que los niños se suban a los muebles, ya que esto puede provocar que se vuelquen y lesiones personales graves. Monte los muebles fuera del alcance de los niños.

**Advertencia:** No coloque los muebles cerca de fuentes de fuego u objetos de alta temperatura para evitar el riesgo de incendio.

**Advertencia:** Limpie los muebles con un paño húmedo o alcohol, evite usar agentes de limpieza que contengan químicos corrosivos.

<b>Importeur</b>	Decobus Handel GmbH		
<b>Adresse</b>	Innungsstraße 9, 21244 Buchholz, Deutschland		
<b>Email/URL</b>	<a href="https://www.decobusgroup.de">https://www.decobusgroup.de</a>		
<b>Hersteller</b>	SHOUGUANG LONGSEN SMART HOME CO.,LTD.		
<b>Adresse</b>	THE EAST OF CAIDU ROAD,SHOUGUANG,CHINA		
<b>Email/URL</b>	550350999@qq.com		
<b>Partienummer</b>	N635P411805 - N635P411806		
<b>Hergestellt in</b>	China		
<table border="1"><tr><td>EC</td><td>REP</td></tr></table>	EC	REP	Decobus Handel GmbH Innungsstraße 9, 21244 Buchholz, Deutschland <a href="https://www.decobusgroup.de">https://www.decobusgroup.de</a>
EC	REP		

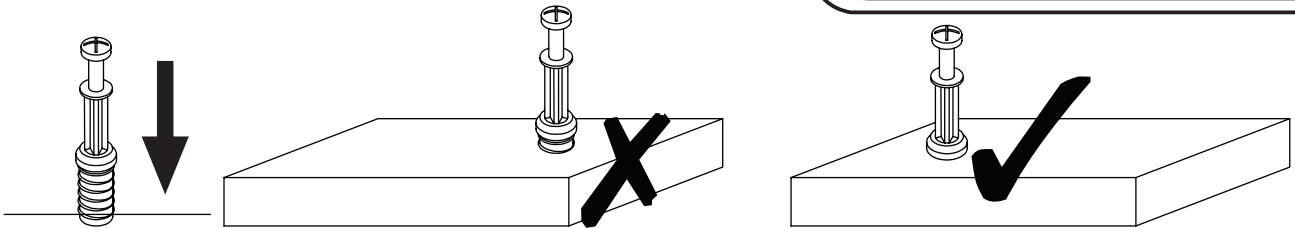

**EN\_QUICKFIT:** Tighten quickfit until shoulder is flush with panel. Do not overtighten or undertighten.

**FR\_RACCORD RAPIDE:** Faites serrer le raccord rapide jusqu'à ce que l'épaulement soit parfaitement encastré dans le panneau. Il ne faut ni trop serrer ni insuffisamment serrer.

**ES\_QUICKFIT:** Apriete quickfit hasta que el hombro se descargue con el panel. NO lo sobreapriete ni lo apriete poco.

**DE\_QUICKFIT:** Ziehen Sie den Quickfit fest, bis die Schulter mit der Platte bündig ist. Bitte nicht zu fest oder zu schwach anziehen.

**IT\_MONTAGGIO RAPIDO:** Stringere il montaggio rapido fino a quando la spalla è a filo con il pannello, non stringere troppo o troppo poco.

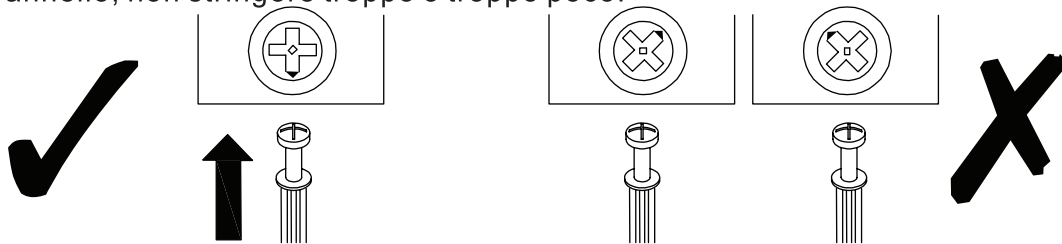

**EN\_CAM LOCK:** When fitting cam lock, ensure starting position is correct before you insert connecting quickfit.

**FR\_SERRURE BATTEUSE:** Avant d'insérer la serrure batteuse, veillez à la bonne orientation avant d'insérer le raccord rapide.

**ES\_CIERRE DE LA CÁMARA:** Cuando instale el cierre de la cámara, asegúrese de que la posición de inicio es correcta antes de que inserte el quickfit conector.

**DE\_CAM-LOCK:** Achten Sie bei der Montage des Cam-Locks auf die richtige Ausgangsposition, bevor Sie den Quickfit einsetzen.

**IT\_BLOCCAGGIO A CAMMA:** Quando si monta il bloccaggio a camma, assicurarsi che la posizione iniziale sia corretta prima di inserire il montaggio rapido di collegamento.

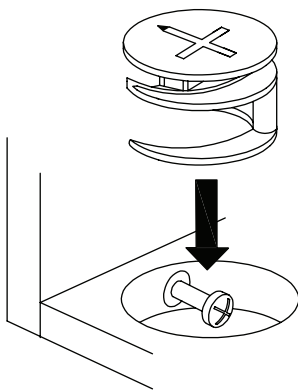

**EN\_Quickfit head** should be in the centre of the cam lock when the two panels are joined.

Cam lock should be inserted before quickfit.

**FR\_Lorsque** les deux panneaux sont assemblés, la tête du raccord rapide doit reposer au centre de la serrure batteuse. Il faut insérer la serrure batteuse avant le raccord rapide.

**ES\_El** cabezal del quickfit debe estar en el centro del cierre de la cámara cuando se unan los dos paneles.

Se debe insertar el cierre de la cámara antes que el quickfit.

**DE\_Der** Quickfit-Kopf sollte sich in der Mitte des Cam-Locks befinden, wenn die beiden Platten zusammengefügt sind. Der Cam-Lock sollte vor dem Quickfit eingesetzt werden.

**IT\_La** testa del montaggio rapido deve trovarsi al centro del bloccaggio a camma quando i due pannelli sono uniti.

Il Bloccaggio a Camma deve essere inserito prima del montaggio rapido.

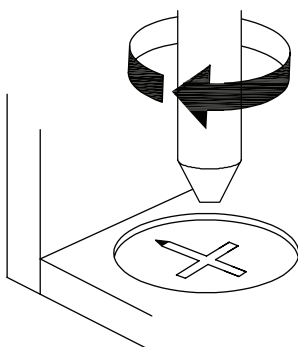

**EN\_Turn** cam lock clockwise to tighten.

**FR\_Faites** tourner la serrure batteuse dans le sens des aiguilles d'une montre pour la resserrer.

**ES\_Gire** el cierre de la cámara en sentido horario para apretarlo.

**DE\_Drehen** Sie den Cam-Lock im Uhrzeigersinn, um ihn festzuziehen.

**IT\_Ruotare** il bloccaggio a camma in senso orario per stringere.

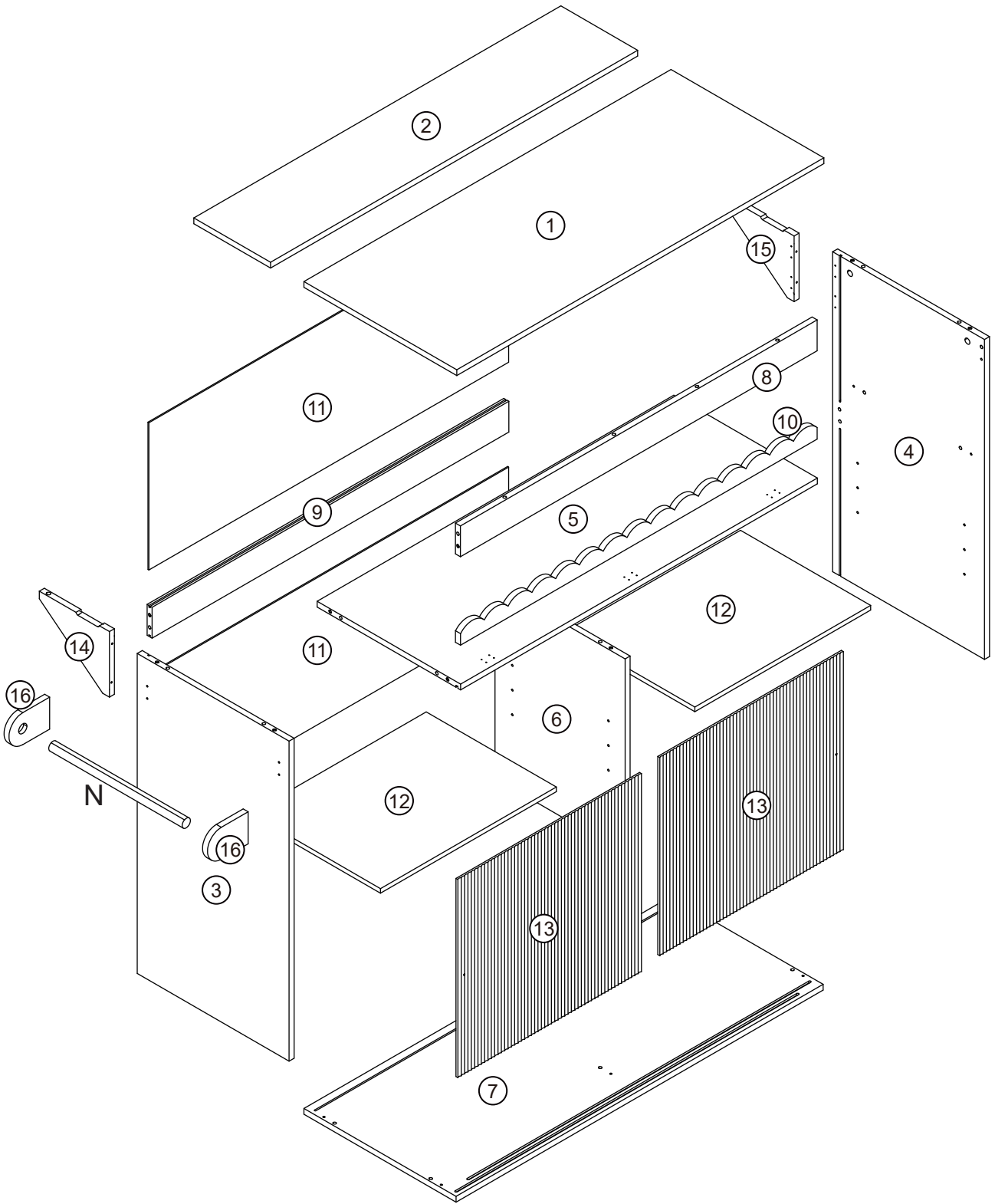

**PARTS**

① x1 	② x1 	③ x1 	④ x1 	⑤ x1 
⑥ x1 	⑦ x1 	⑧ x1 	⑨ x1 	⑩ x1 
⑪ x2 	⑫ x2 	⑬ x2 	⑭ x1 	⑮ x1 
⑯ x2 				

**HARDWARE**

**N635P411806**

A 22 pcs 	B 22 pcs 	C 16 pcs  φ8*30mm	D 6 pcs  φ5*40mm	E 4 pcs  φ7*50mm	F 2 pcs 
G 2 pcs 	H 4 pcs 	J 3 pcs 	K 4 pcs 	L 3 pcs 	M 2 pcs 
N 1 pc  φ25*400mm	O 8 pcs 	P 3 pcs 	R 2 pcs 	S 90 pcs  φ3.5*14mm	T 1 pc 
U 32 pcs 	V 8 pcs 				

# N635P411805

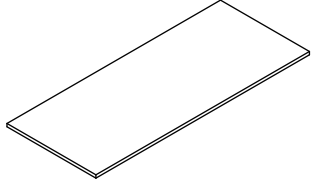
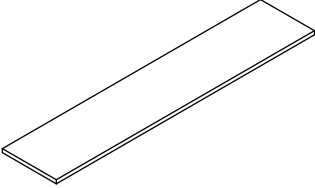
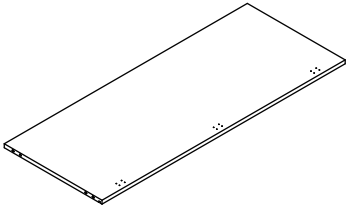
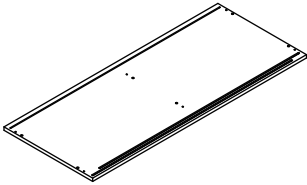
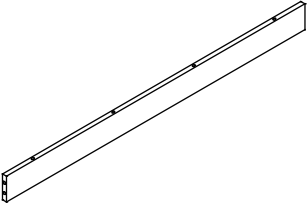
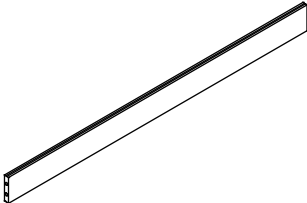
NO.	PARTS	QTY
①		1
②		1
⑤		1
⑦		1
⑧		1
⑨		1

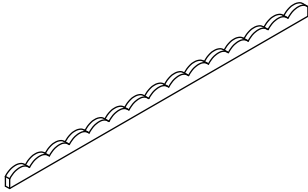
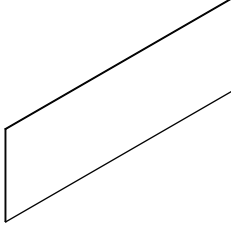
NO.	PARTS	QTY
⑩		1
⑪		2

# N635P411806

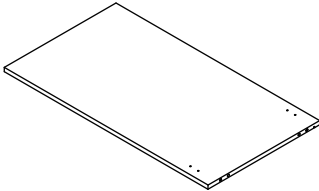
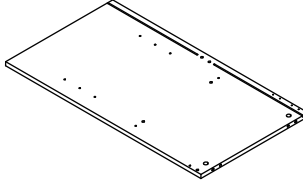
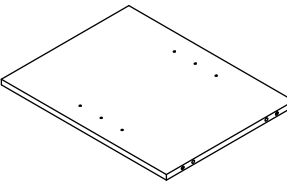
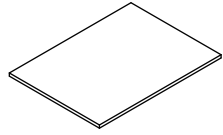
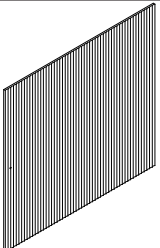
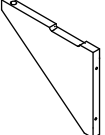
NO.	PARTS	QTY
3		1
4		1
6		1
12		2
13		2
14		1

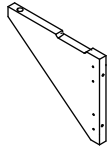
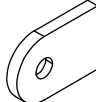
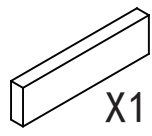
NO.	PARTS	QTY
15		1
16		2
 <p>X1 Hardware Kit</p>		

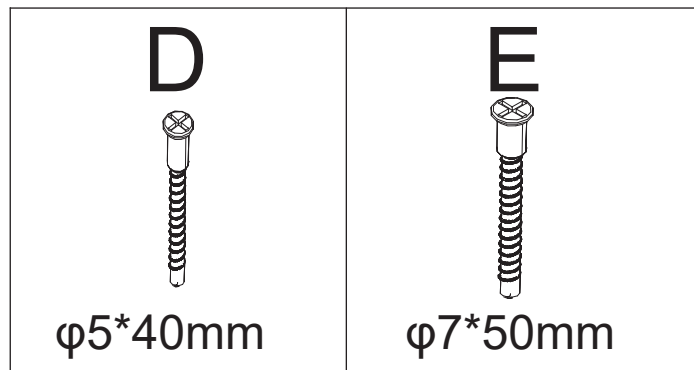

DE: Bitte beachten Sie, dass die Formen der Schrauben D und SE ähnlich sind.  
Bitte installieren Sie nach den Anweisungen und unterscheiden Sie sie.

EN: Please note that the shapes of screws D and E are similar.  
Please install according to the instructions and distinguish them.

FR: Veuillez noter que les formes des vis D et E sont similaires.  
Veuillez installer selon les instructions et les distinguer.

IT: Si prega di notare che le forme delle viti D e E sono simili.  
Si prega di installare secondo le istruzioni e distinguerli.

ES: Tenga en cuenta que las formas de los tornillos D y E son similares.  
Por favor, instale de acuerdo con las instrucciones y distinguirlos.

# Step 1

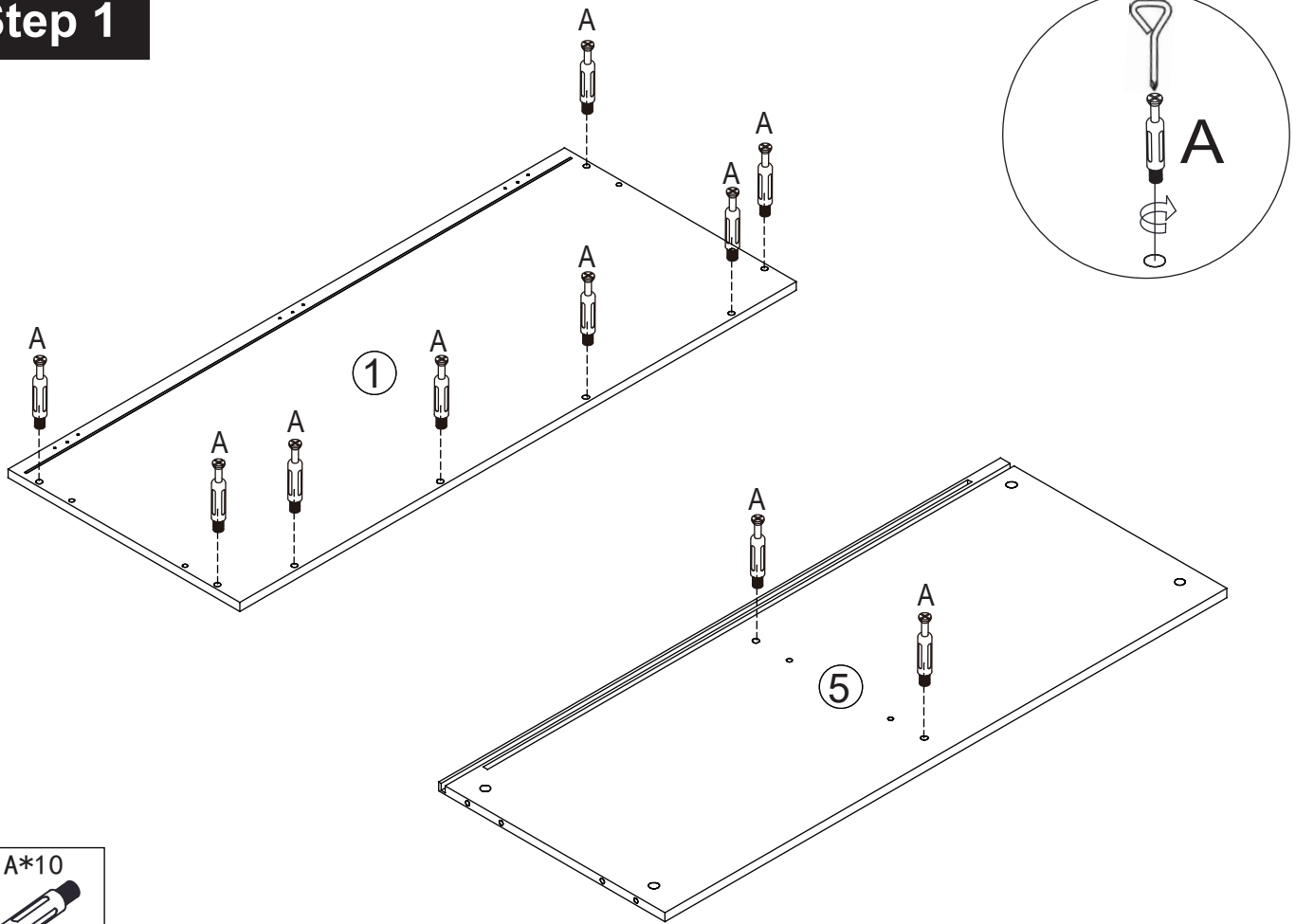

A\*10



# Step 2

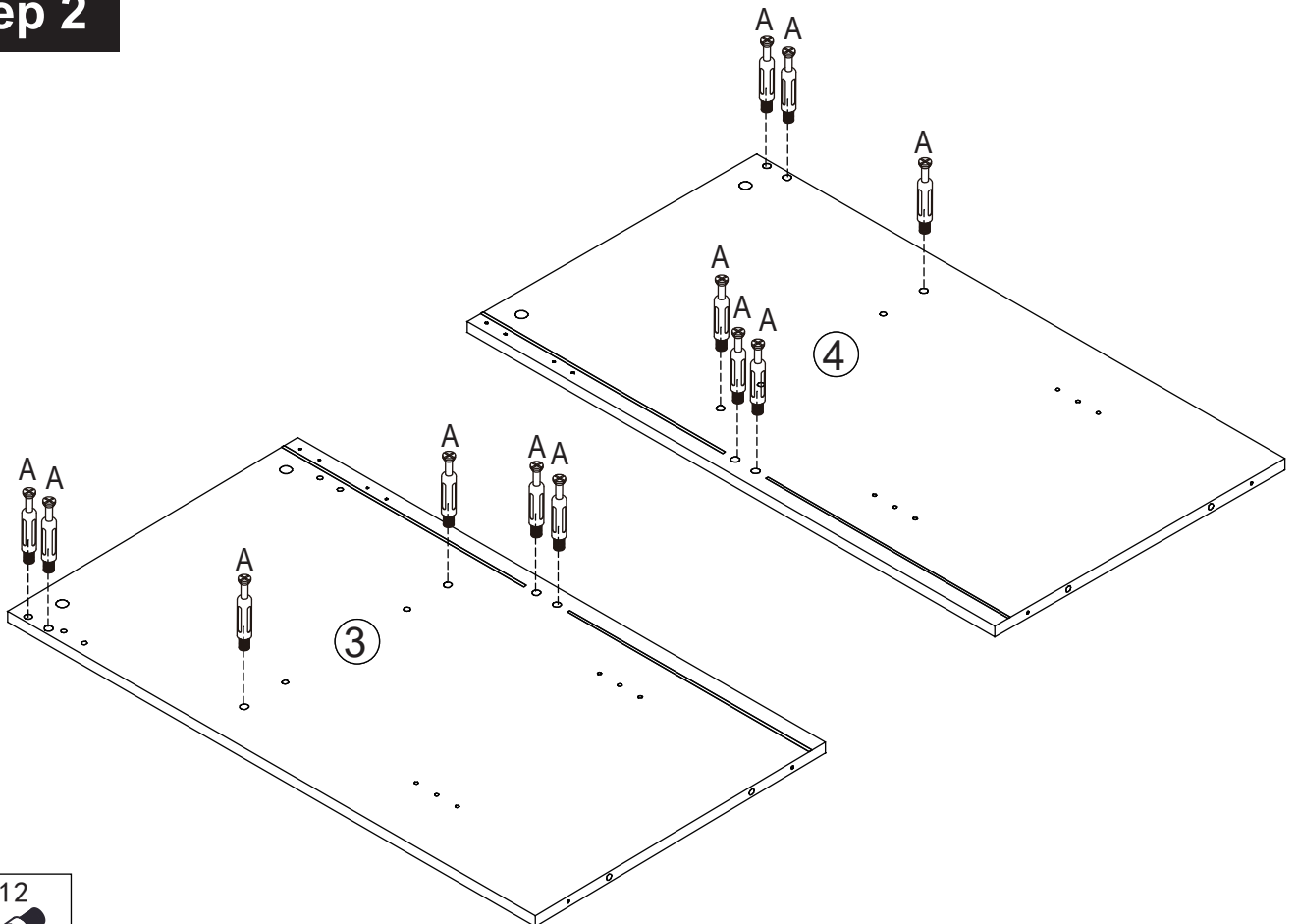

A\*12



### Step 3

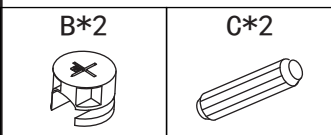
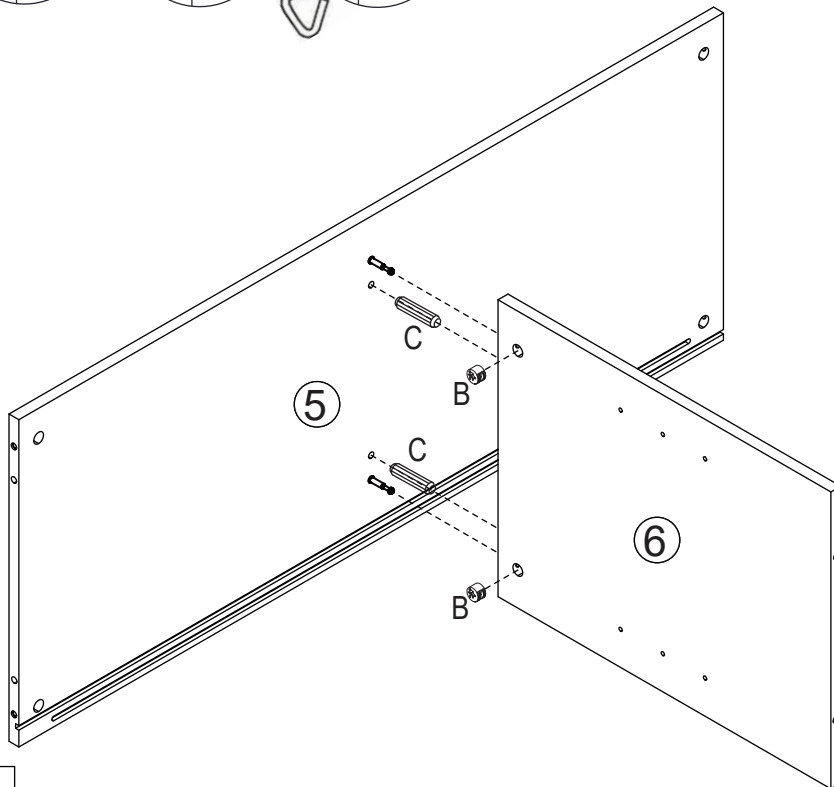
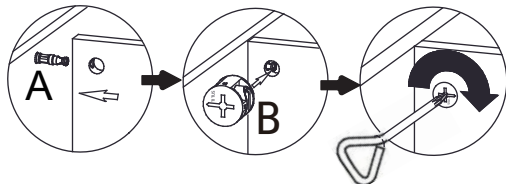

### Step 4

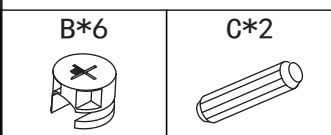
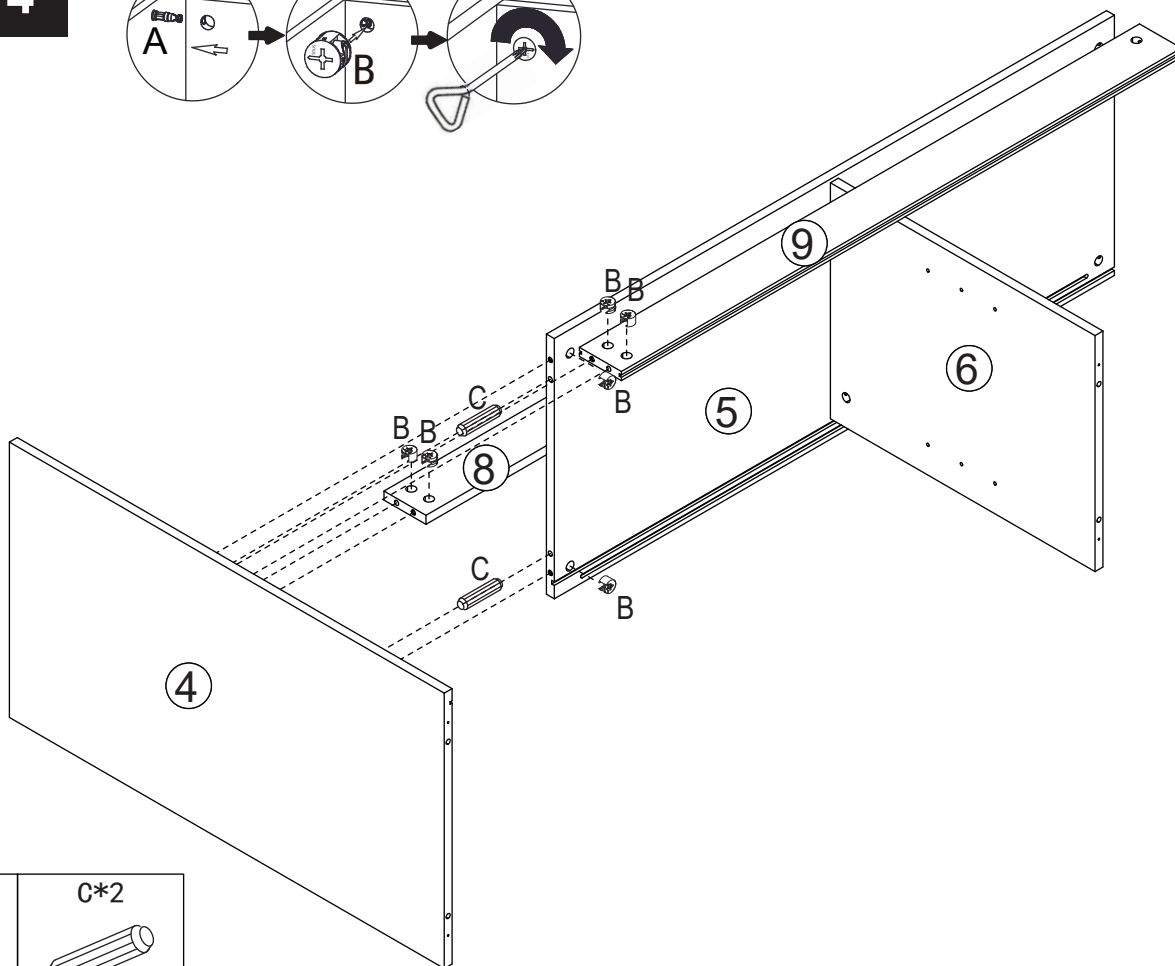
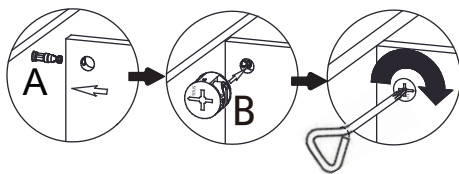

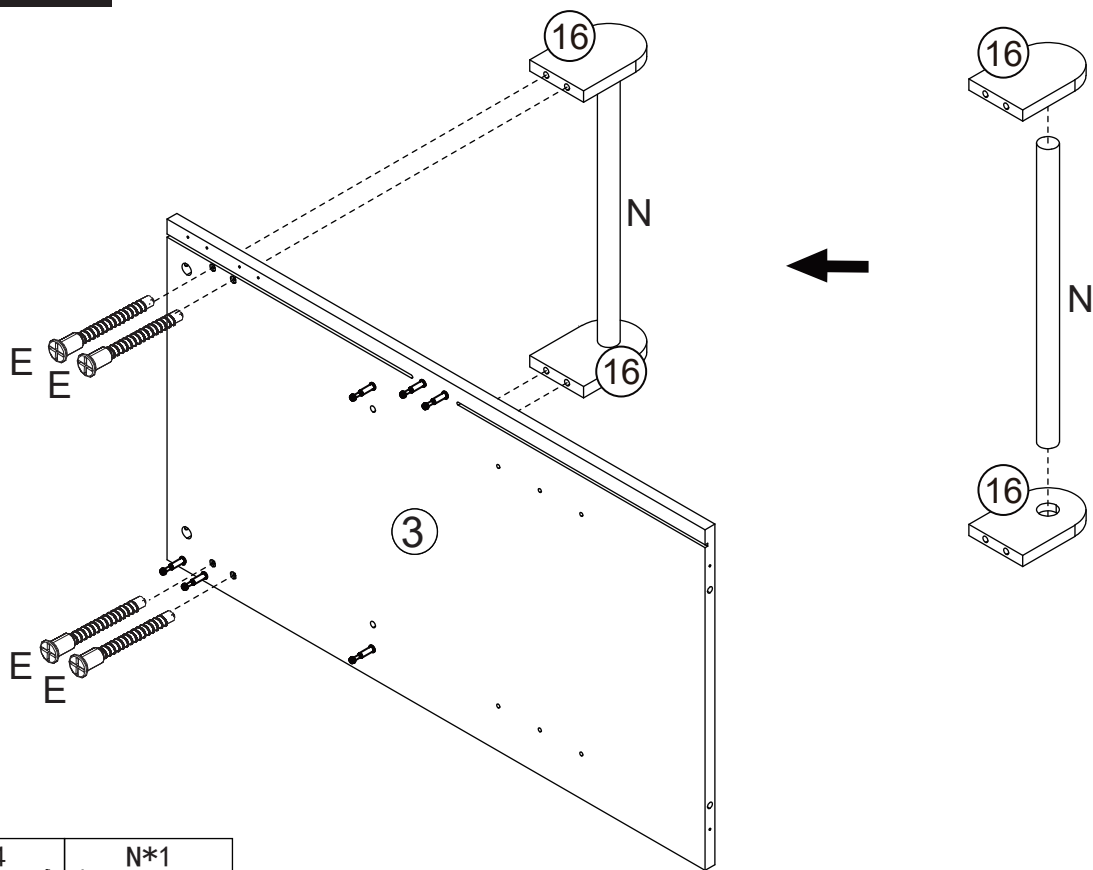

# Step 5

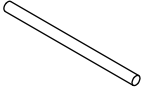

E*4	N*1
	

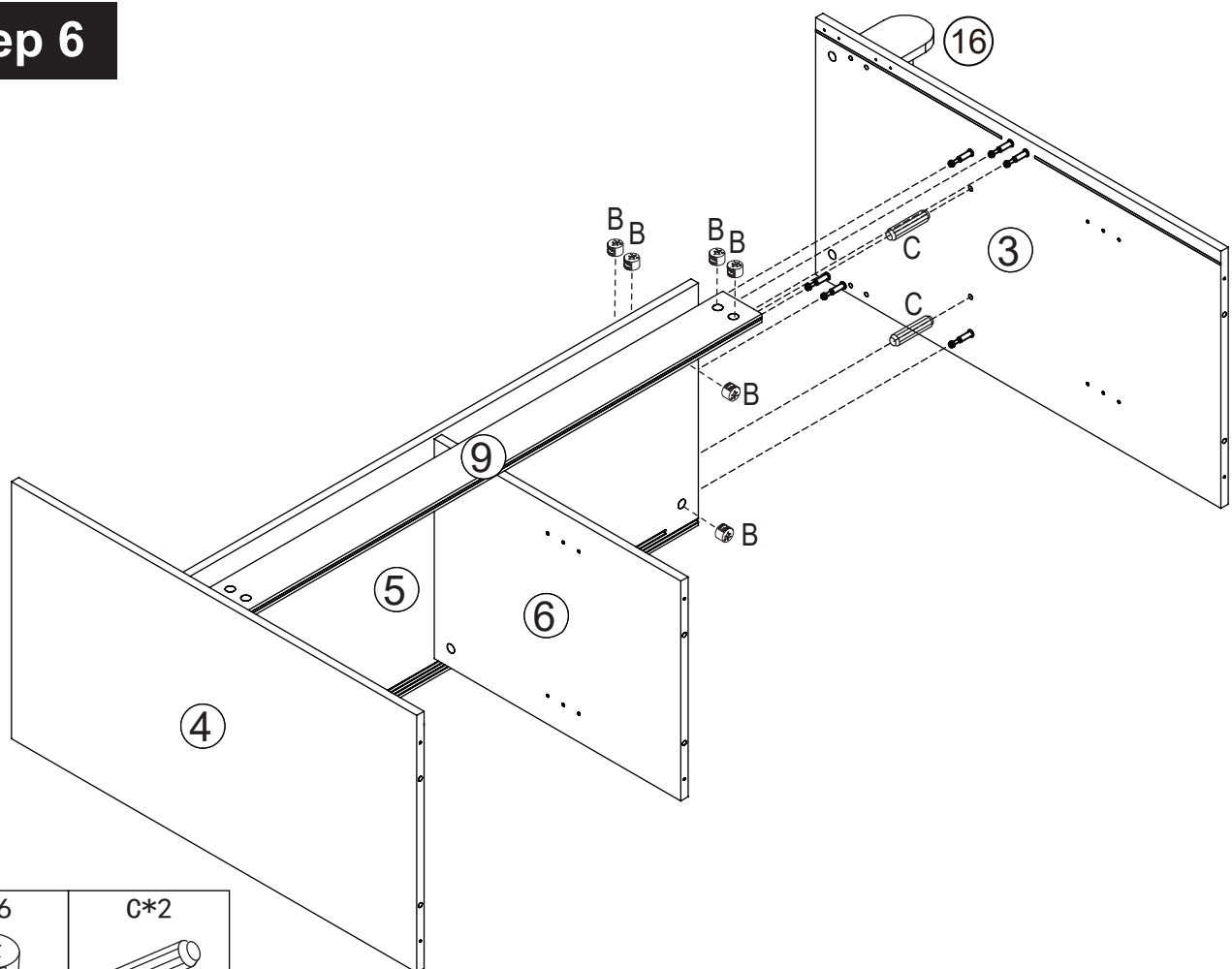
# Step 6

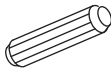

B*6	C*2
	

# Step 7

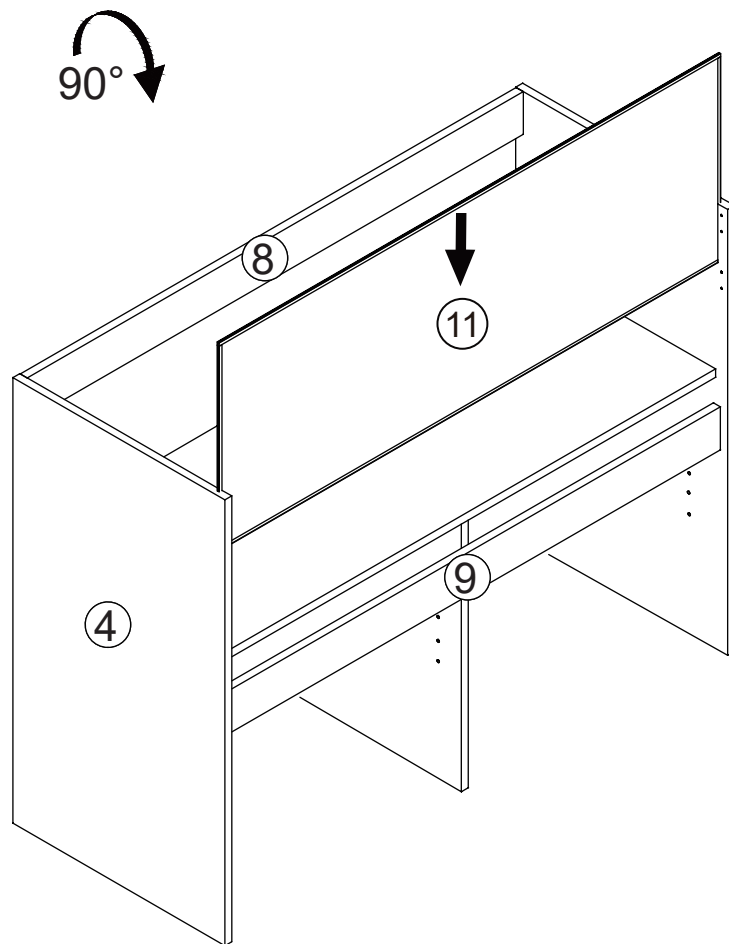

# Step 8

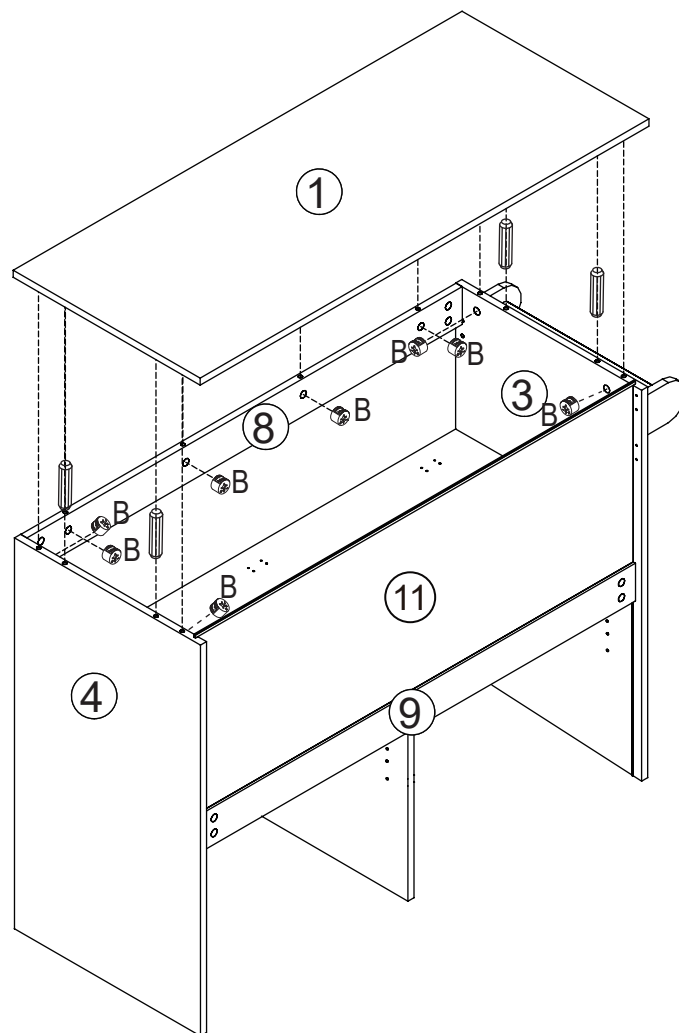



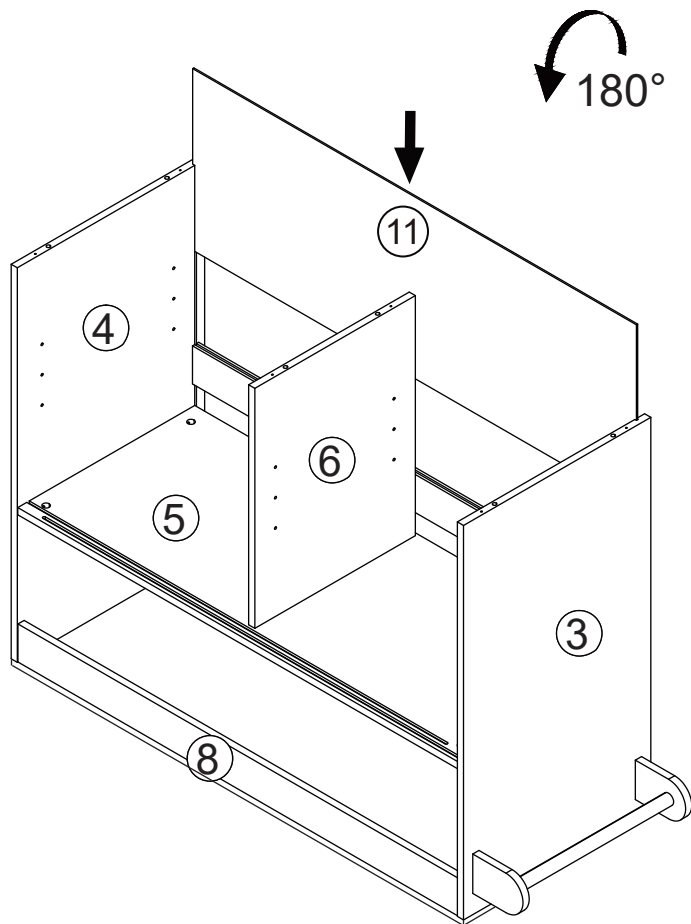

B*8	C*4

# Step 9

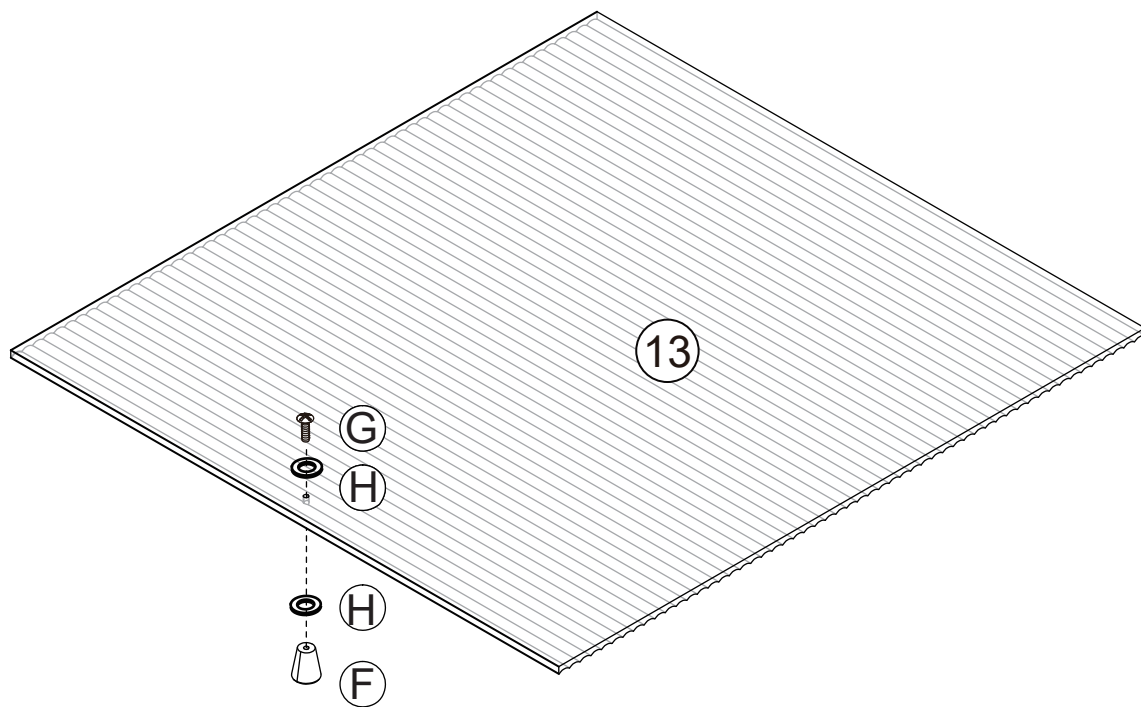

# Step 10 StepX2



F*2	G*2	H*4
		

## Step 11

DE: Es ist besser, wenn zwei oder mehr Menschen an diesem Schritt zusammenarbeiten.

EN: It's better if two or more people work together on this step.

FR: Il est préférable que deux personnes ou plus travaillent ensemble sur cette étape.

IT: È meglio se due o più persone lavorano insieme in questo passo.

ES: Es mejor que dos o más personas trabajen juntos en este paso.

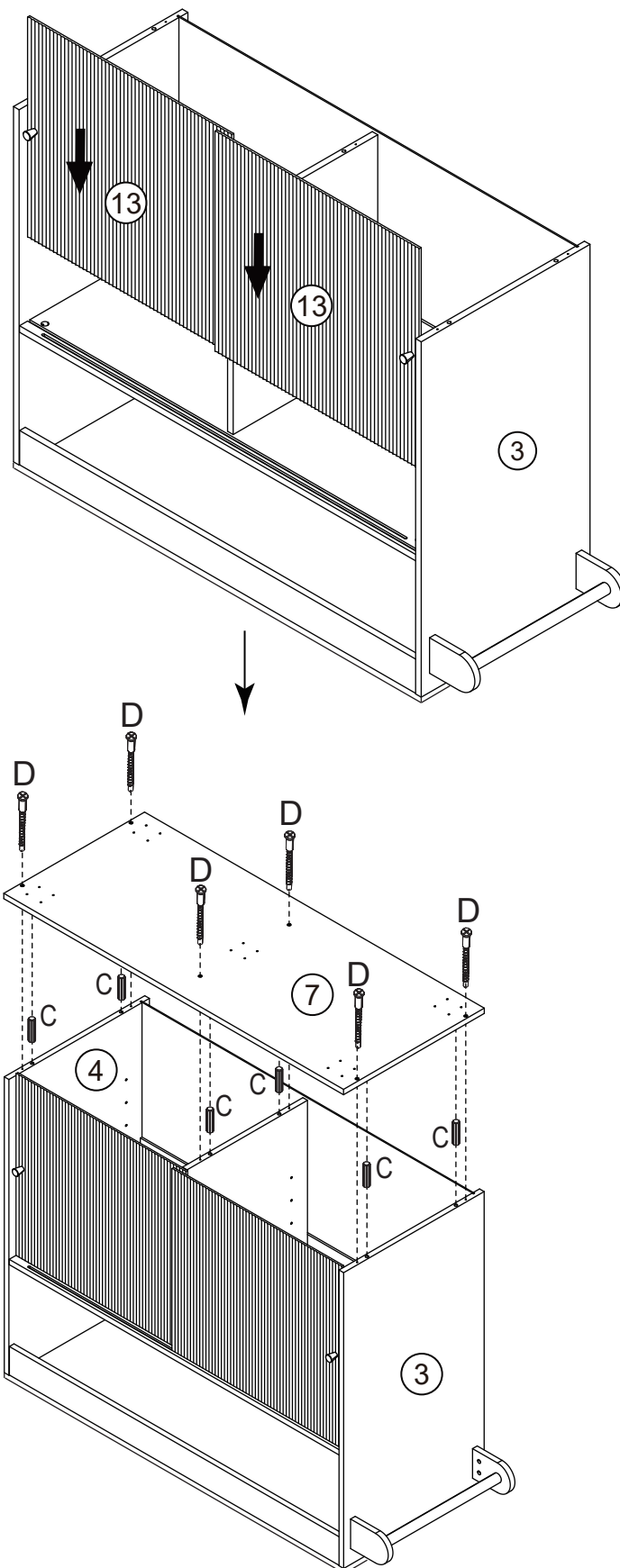

C\*6

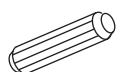

D\*6



# Step 12

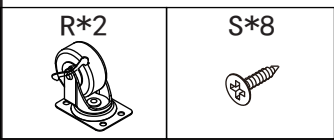
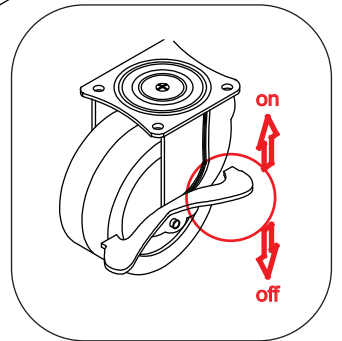
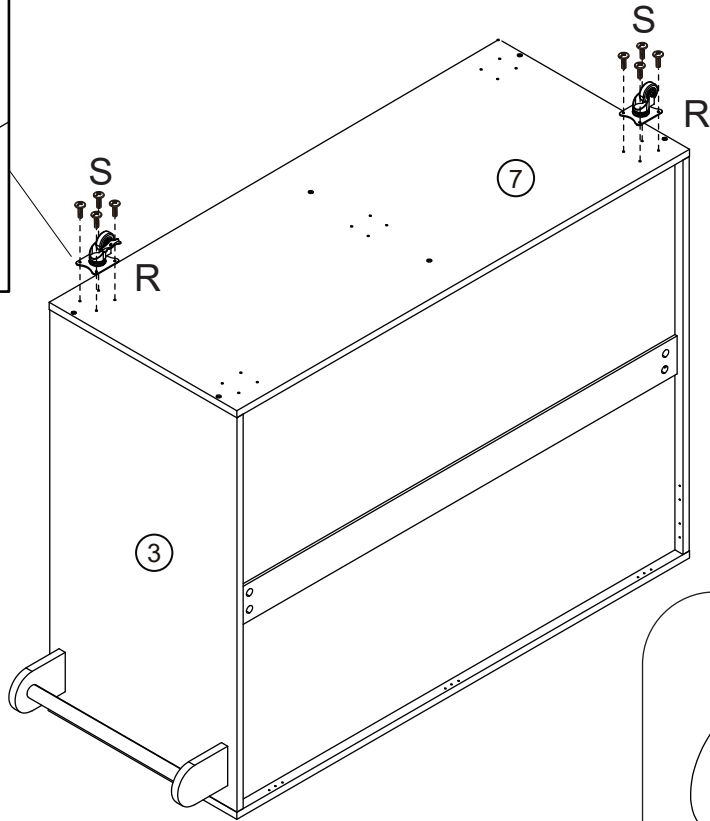
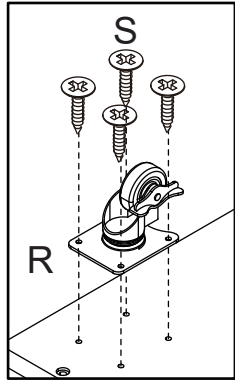

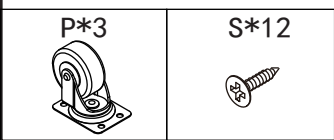
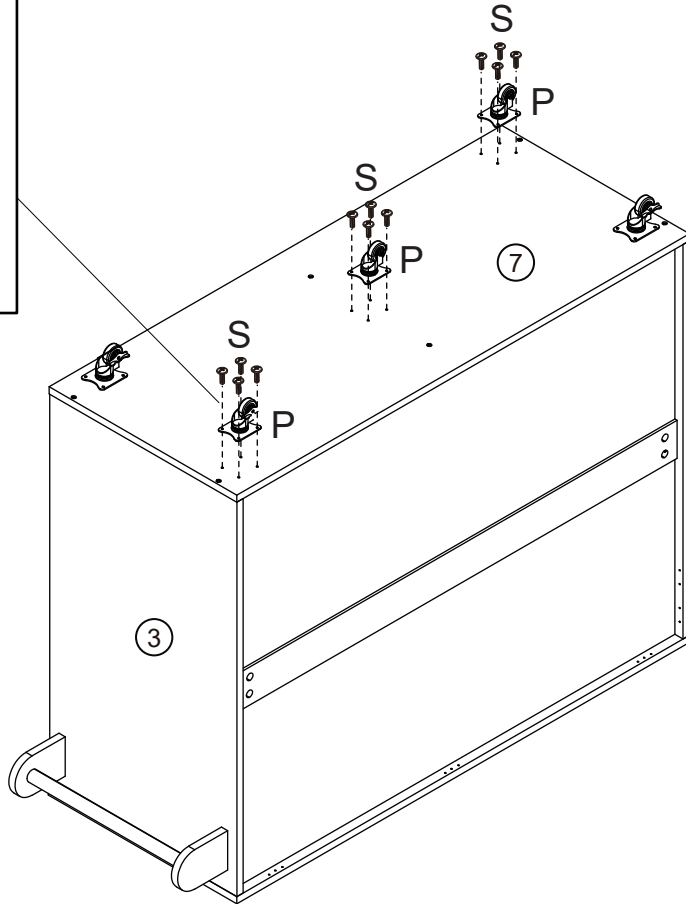
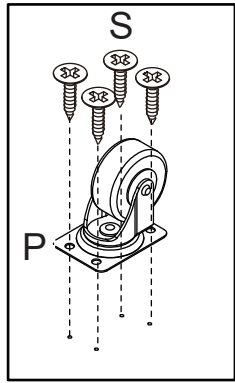

# Step 13



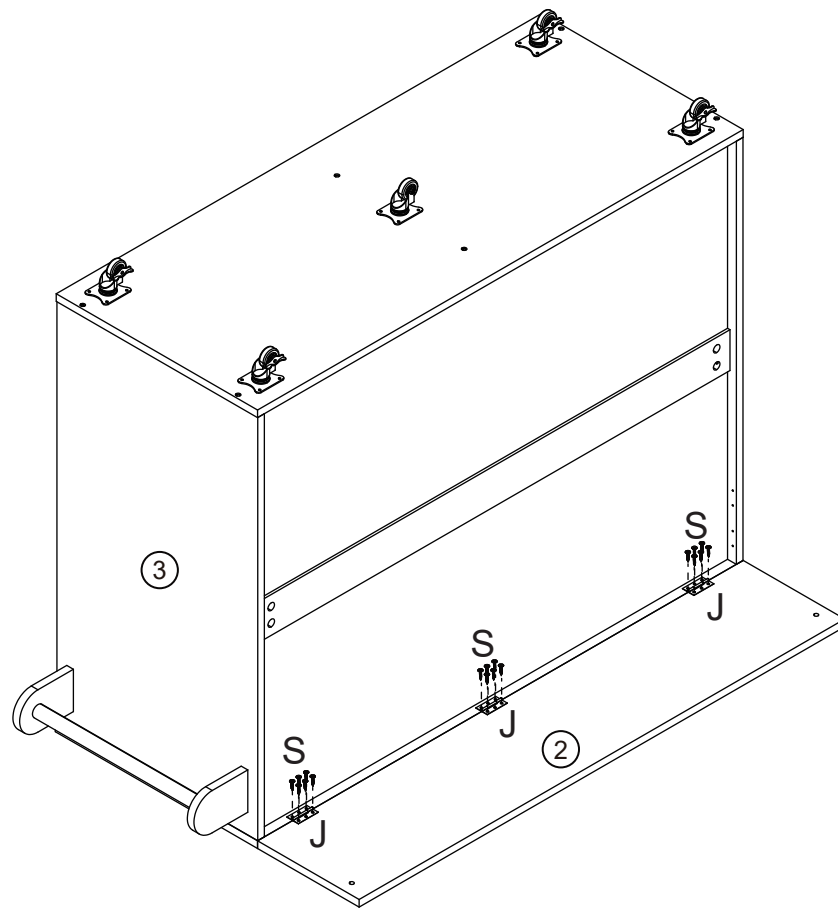

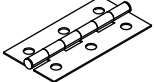
# Step 14

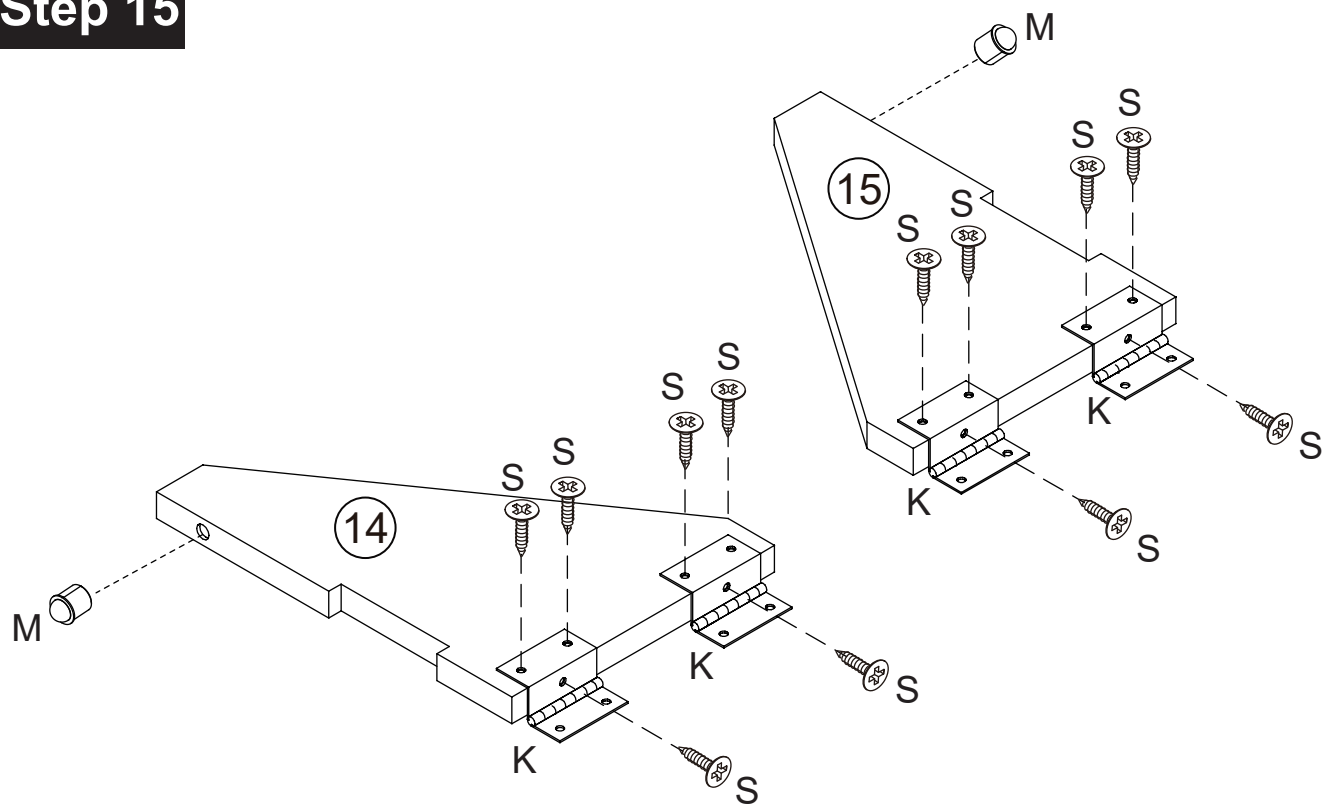

J*3	S*18
	

# Step 15

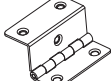

K*4	S*12	M*2
		

## Step 16

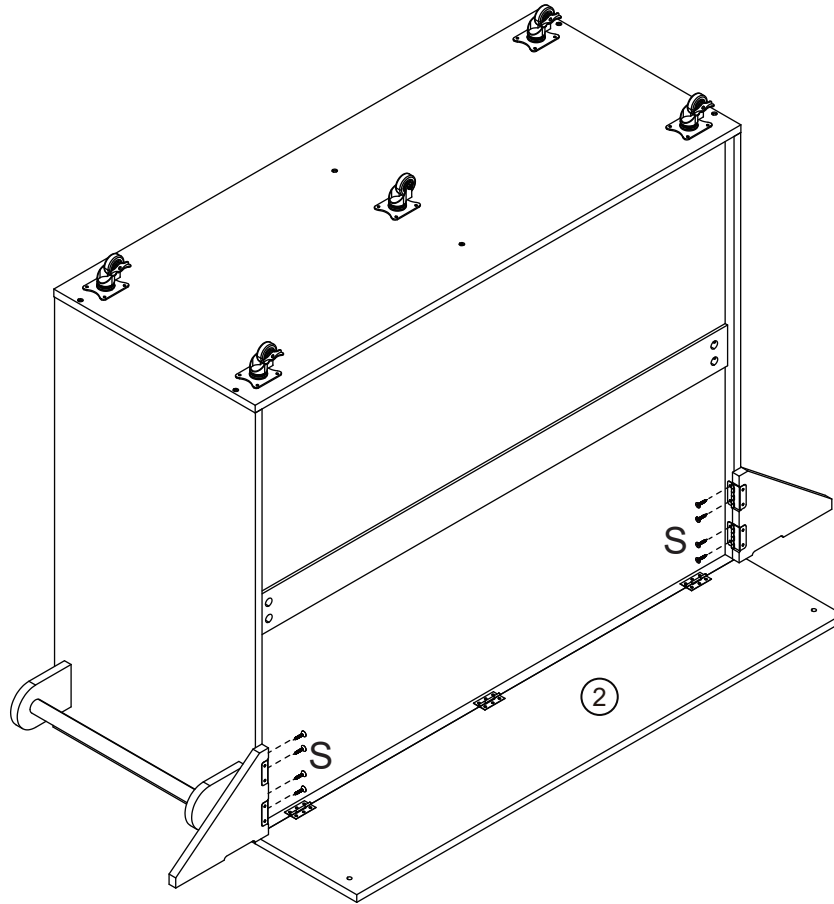

S\*8



## Step 17

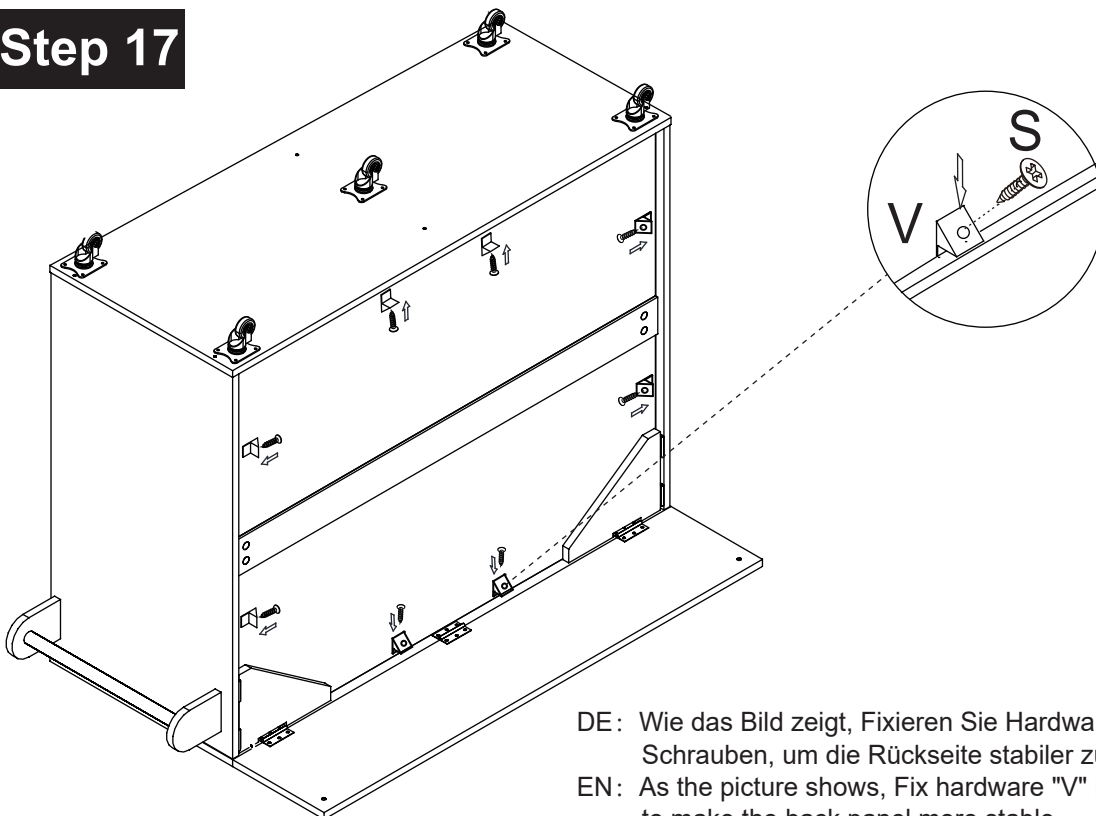

V\*8



S\*8



DE: Wie das Bild zeigt, Fixieren Sie Hardware "V" in den Spalt mit Schrauben, um die Rückseite stabiler zu machen.

EN: As the picture shows, Fix hardware "V" into the gap with screws to make the back panel more stable.

FR: Comme le montre l'image, Fixez le matériel "V" dans l'écart avec des vis pour rendre le panneau arrière plus stable.

IT: Come mostra l'immagine, fissare il componente "V" nel gap con viti per rendere il pannello posteriore più stabile.

ES: Como se muestra en la imagen, fije el hardware "N" en el hueco con tornillos para hacer que el panel trasero sea más estable.Q

# Step 18

180°

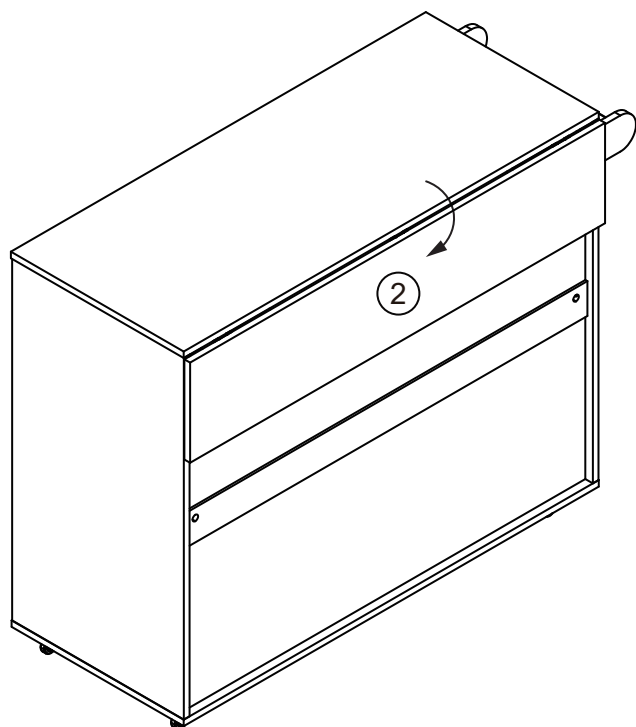
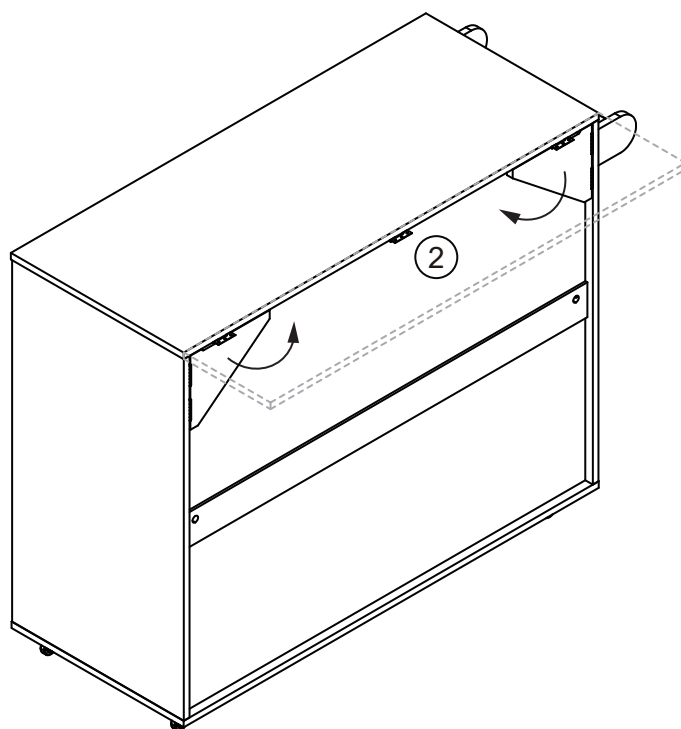
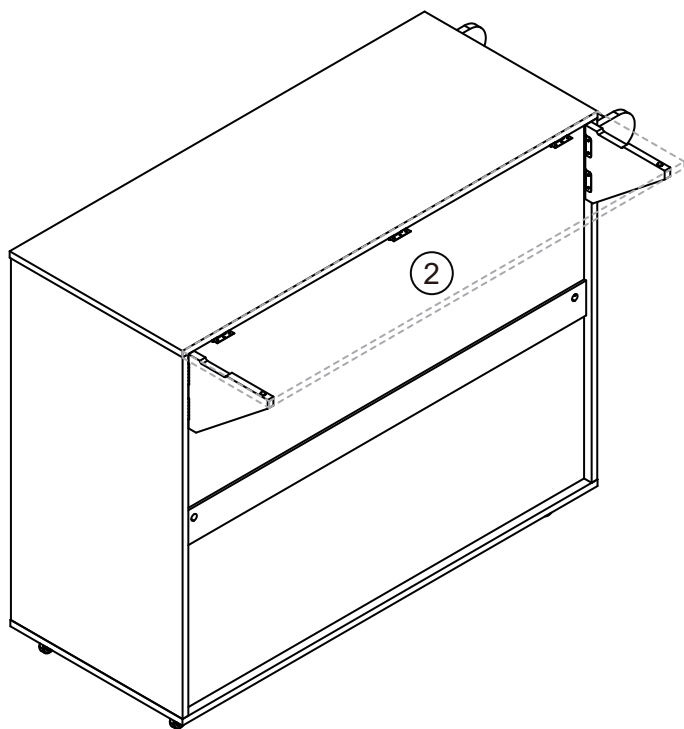

# Step 19

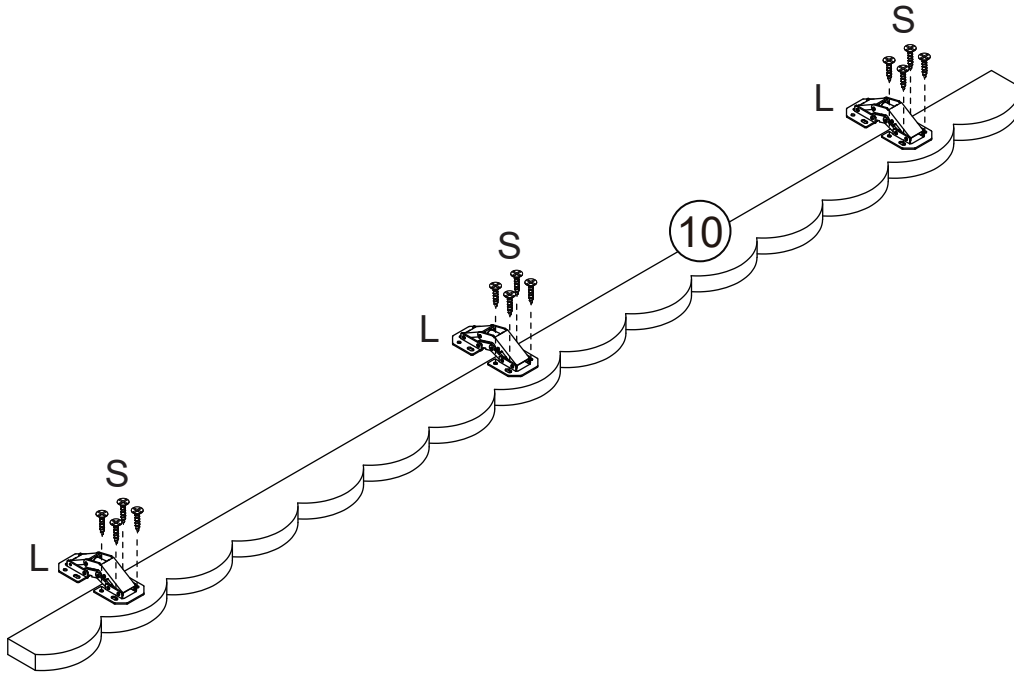

L\*3

S\*12



# Step 20

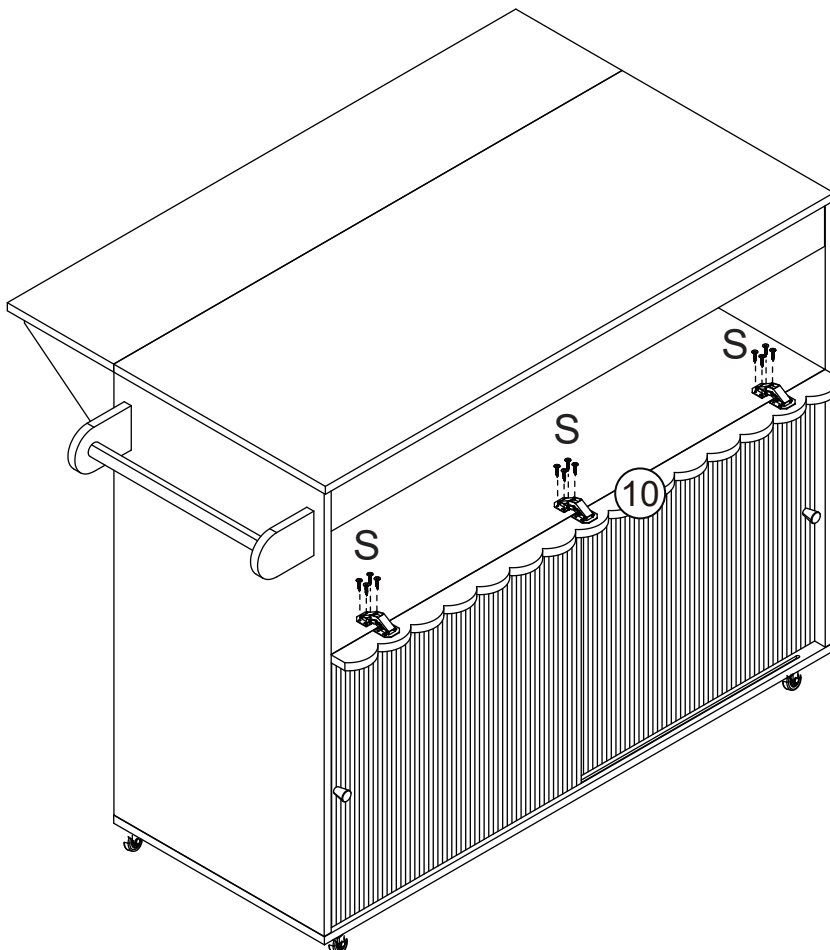

S\*12



## Step 21

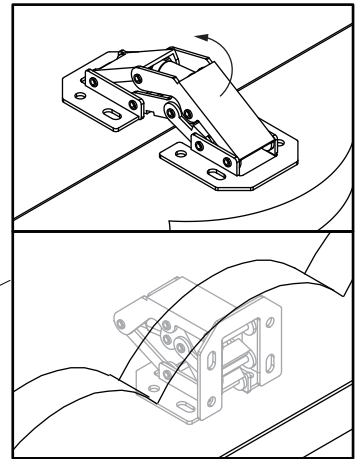
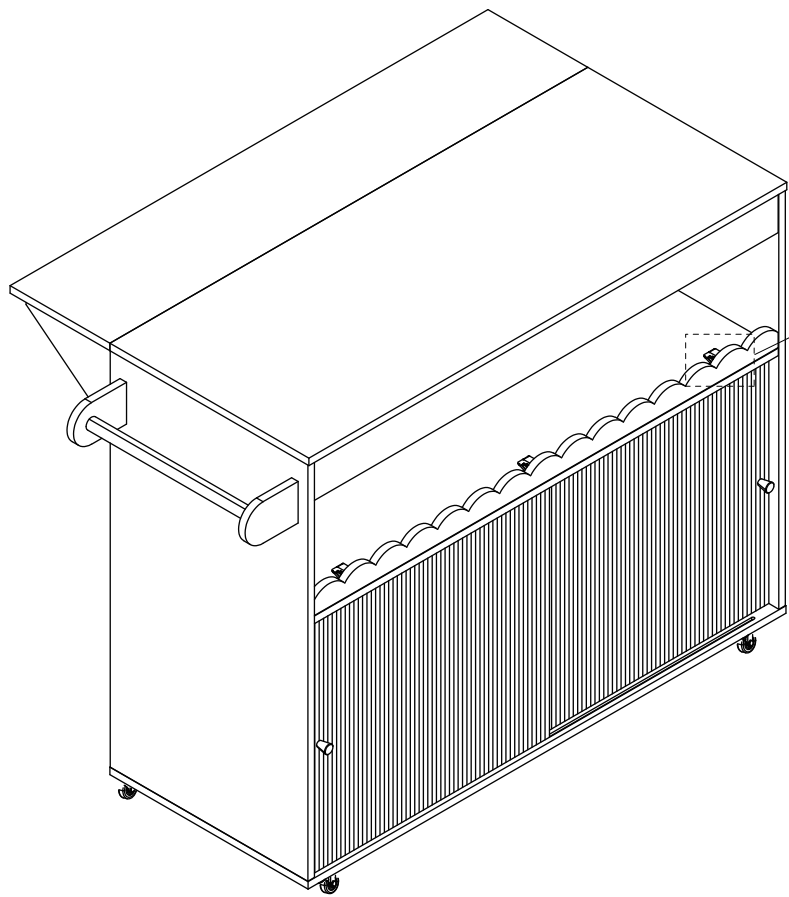

## Step 22

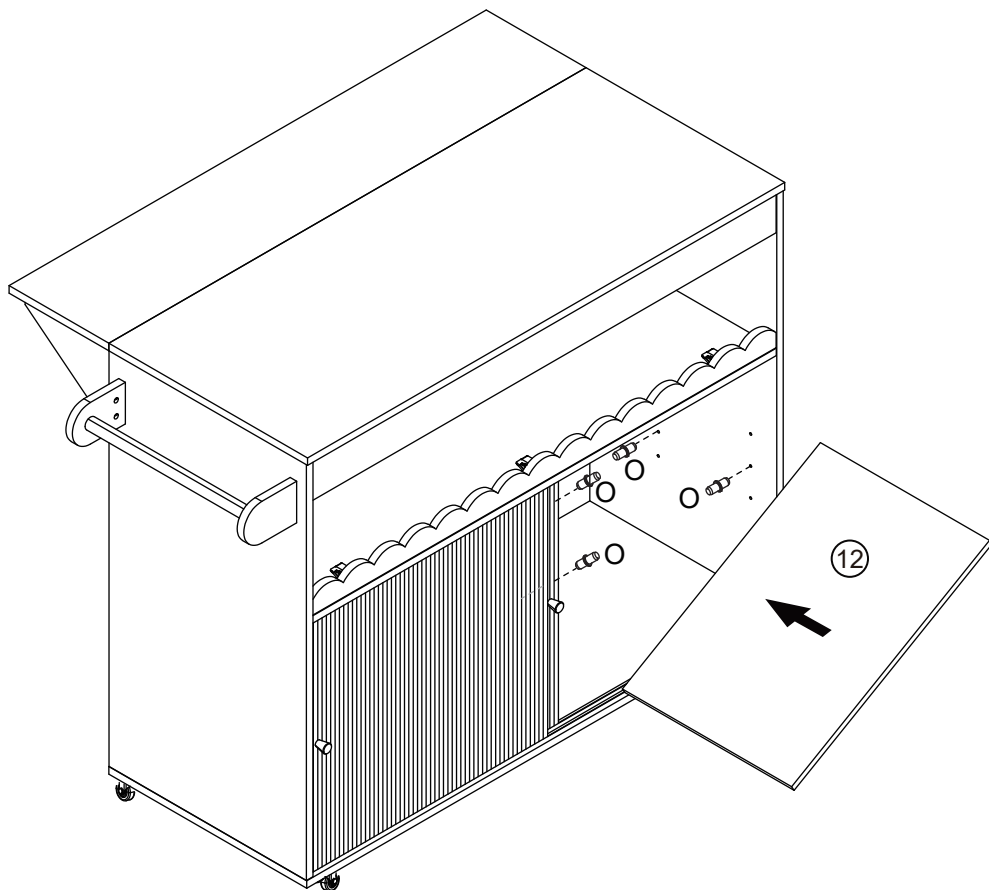

0\*4



## Step 23

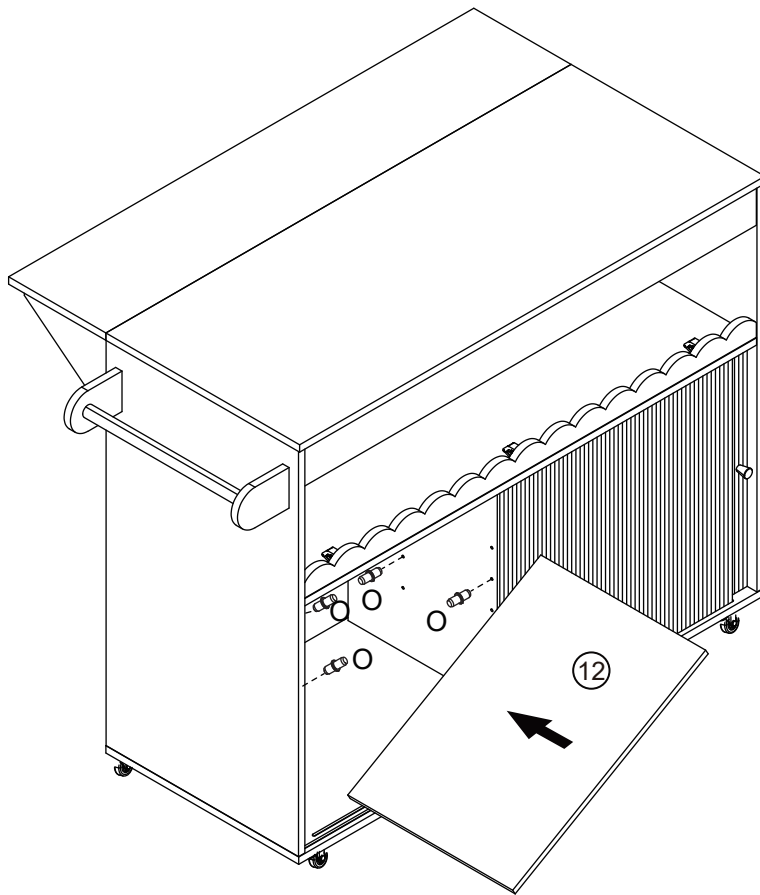

0\*4



## Step 24

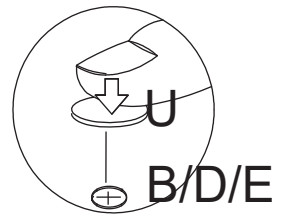
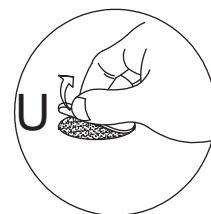
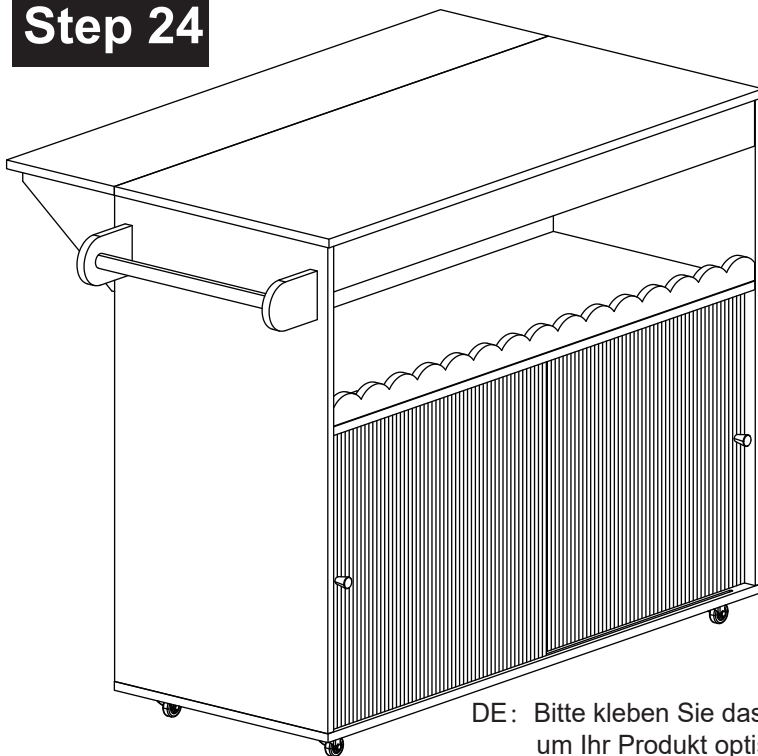

DE: Bitte kleben Sie das Hardware-Teil "U" auf das offene Kammerschlittloch, um Ihr Produkt optisch ansprechender zu gestalten.

EN: Please stick the hardware "U" on the exposed cam lock hole that makes your product more beautiful.

FR: Veuillez coller le matériel "U" sur le trou de verrouillage de came exposé pour rendre votre produit plus esthétique.

IT: Per favore, incollare il componente "U" sul foro del serratura a came esposto per rendere il vostro prodotto più elegante.

ES: Por favor, pegue el hardware "U" en el agujero del cerrojo de leva expuesto para hacer que su producto sea más bonito.

U\*32



# Step 25

