

**N657P421026**  
**N657P421027**  
**N657P421028**  
**N657P421029**

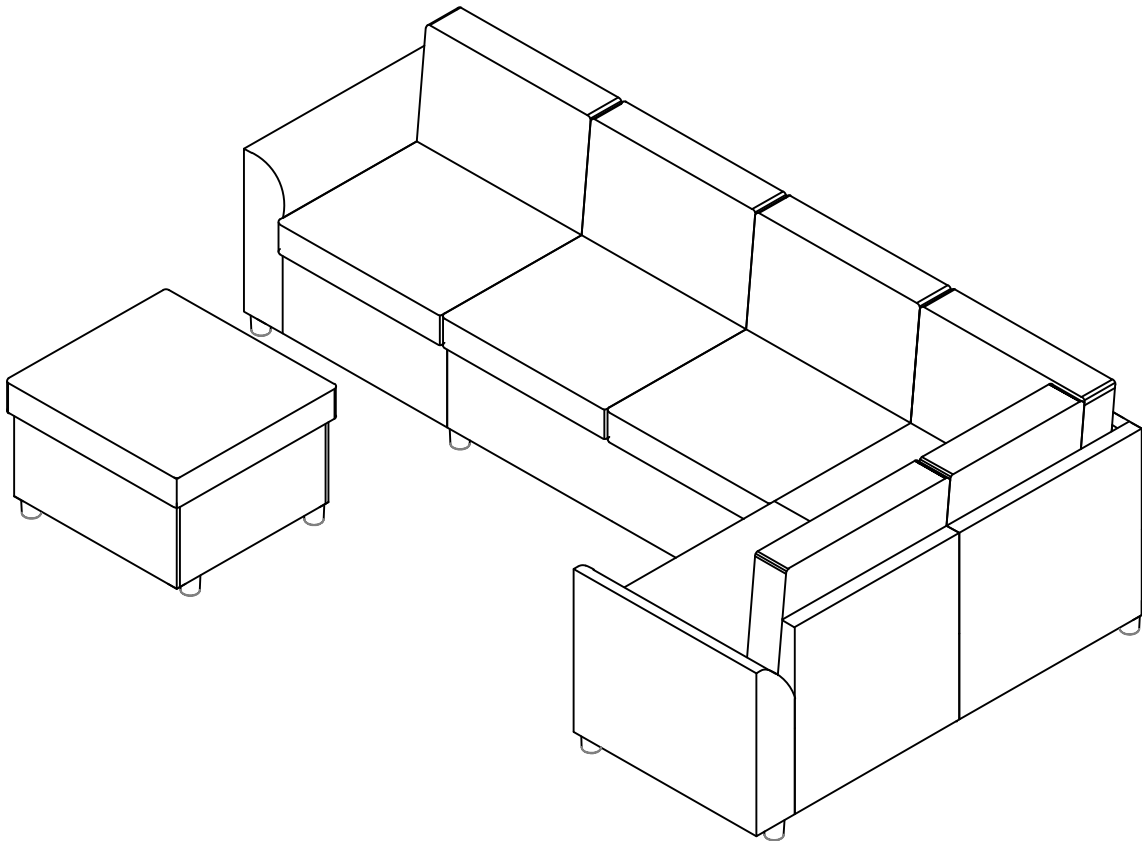

Sets werden normalerweise in mehreren Kartons  
versendet, die Liefertermine können variieren

## **KUNDENDIENST**

Fragen, fehlende Teile, Montagehilfe?  
Eine Rücksendung ist nicht erforderlich, wir helfen Ihnen gerne weiter und  
versenden Ihr Ersatzteil kostenlos.



## [DE]

**Achtung:** Lesen Sie die Anleitung vor dem Zusammenbau bitte vollständig durch. Überprüfen Sie, ob Sie alle auf den Seiten aufgeführten Komponenten und Werkzeuge haben.

**Achtung:** Überprüfen Sie regelmäßig alle Beschläge und Befestigungen, um sicherzustellen, dass sie sicher sind und um Unfälle zu vermeiden.

**Achtung:** Stellen Sie Möbel nicht in die Nähe von Feuerquellen oder heißen Gegenständen, um Brandgefahr zu vermeiden.

**Achtung:** Erlauben Sie Kindern nicht, auf die Möbel zu klettern, da dies zum Umkippen und zu schweren Verletzungen führen kann. Bauen Sie die Möbel außerhalb der Reichweite von Kindern zusammen.

## [EN]

**Warning:** Please read instructions fully before starting assembly. Check you have all the components and tools listed on pages.

**Warning:** Regularly check all fittings and fastenings to ensure they are secure and to prevent accidents

**Warning:** Do not place furniture close to fire sources or high-temperature objects to avoid the risk of fire.

**Warning:** Do not allow children to climb on the furniture as this may result in tipping and serious personal injury. Assemble the furniture away from the reach of children.

## [FR]

**Avertissement:** Veuillez lire entièrement les instructions avant de commencer l'assemblage. Vérifiez que vous disposez de tous les composants et outils répertoriés sur les pages.

**Avertissement:** Vérifiez régulièrement tous les accessoires et fixations pour vous assurer qu'ils sont bien fixés et pour éviter les accidents

**Avertissement:** Ne placez pas les meubles à proximité de sources de feu ou d'objets à haute température pour éviter tout risque d'incendie.

**Avertissement:** Ne laissez pas les enfants grimper sur les meubles car cela pourrait entraîner un basculement et des blessures graves. Assemblez les meubles hors de portée des enfants.

## [IT]

**Attenzione:** leggere attentamente le istruzioni prima di iniziare il montaggio. Verificare di avere tutti i componenti e gli utensili elencati nelle pagine.

**Attenzione:** controllare regolarmente tutti i raccordi e gli elementi di fissaggio per assicurarsi che siano sicuri e prevenire incidenti

**Attenzione:** non posizionare i mobili vicino a fonti di fuoco o oggetti ad alta temperatura per evitare il rischio di incendio.

**Attenzione:** non consentire ai bambini di arrampicarsi sui mobili poiché ciò potrebbe causare ribaltamenti e gravi lesioni personali. Montare i mobili lontano dalla portata dei bambini.

## [ES]

**Advertencia:** Lea las instrucciones completamente antes de comenzar el montaje. Compruebe que tiene todos los componentes y herramientas que se enumeran en las páginas.

**Advertencia:** Compruebe periódicamente todos los accesorios y sujeciones para asegurarse de que estén seguros y evitar accidentes.

**Advertencia:** No coloque los muebles cerca de fuentes de fuego u objetos a alta temperatura para evitar el riesgo de incendio.

**Advertencia:** No permita que los niños se suban a los muebles, ya que esto puede provocar que vuelquen y lesiones personales graves. Monte los muebles fuera del alcance de los niños.



**[DE]**

**Warnung:** Die maximale Belastbarkeit dieses Möbels beträgt: 150 kg, bitte nicht überlasten!

**[EN]**

**Warning:** The maximum load-bearing capacity of this furniture is: 150 kg, please do not overload!

**[FR]**

**Avertissement:** La capacité de charge maximale de ce meuble est de : 150 kg, merci de ne pas surcharger !

**[IT]**

**Attenzione:** La capacità di carico massima di questo mobile è: 150 kg, non sovraccaricare!

**[ES]**

**Advertencia:** La capacidad máxima de carga de este mueble es: 150 kg, ¡no lo sobrecargue!

Importeur	Decobus Handel GmbH
Adresse	Innungsstraße 9, 21244 Buchholz, Deutschland
Email/URL	<a href="https://www.decobusgroup.de">https://www.decobusgroup.de</a>
Hersteller	FUJIAN MINGHONGSEN SMART HOME CO., LT
Adresse	Factory Building 1, No. 6, Shengda East Road, Yanxi Town, Changtai District, Zhangzhou City, Fujian Province
Email/URL	<a href="mailto:zzxhxznjj@163.com">zzxhxznjj@163.com</a>
partienummer	N657P421026/ N657P421027/ N657P421028/ N657P421029
Hersteller in	Hergestellt In china
	Decobus Handel GmbH Innungsstraße 9, 21244 Buchholz, Deutschland <a href="https://www.decobusgroup.de">https://www.decobusgroup.de</a>

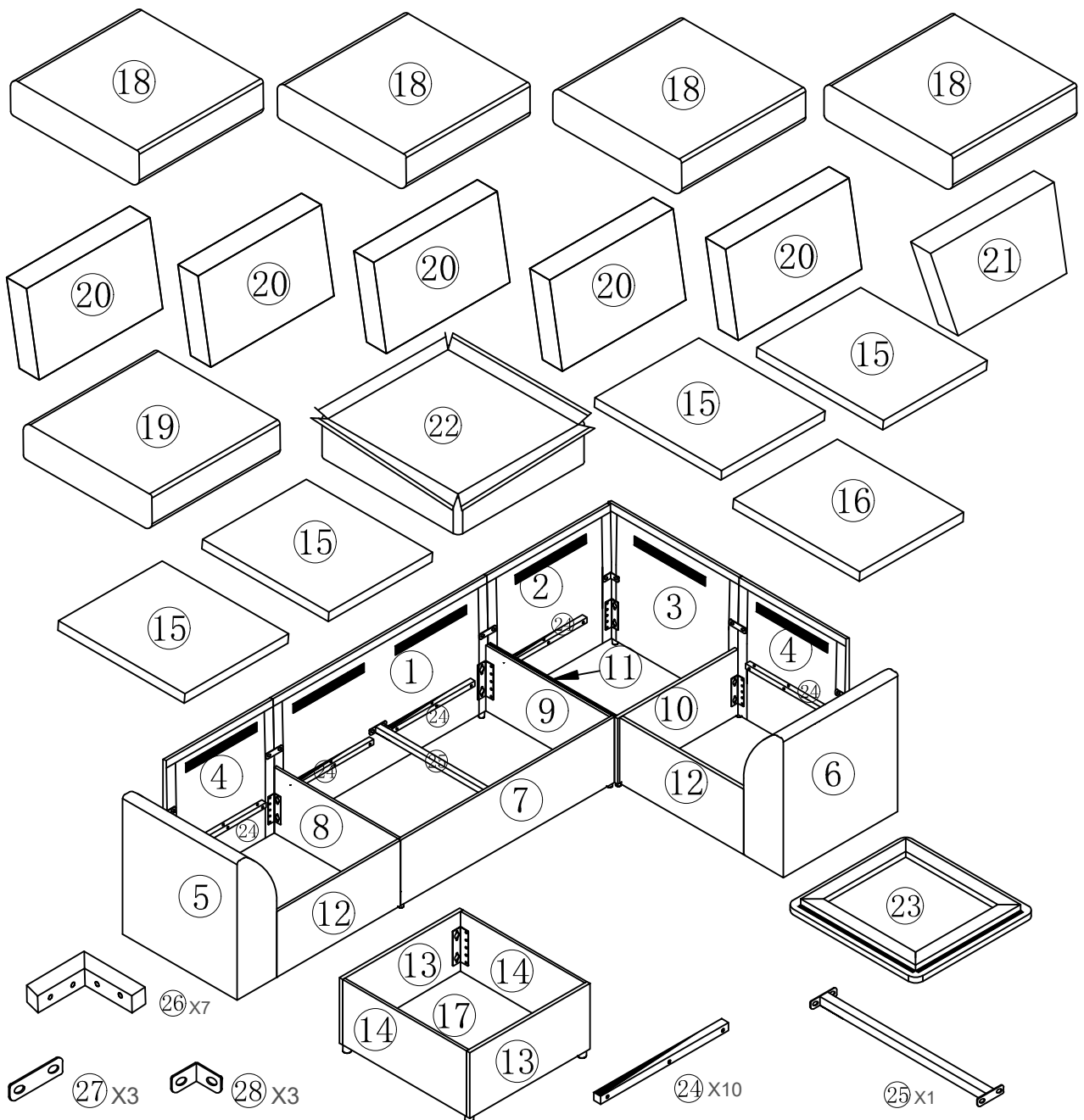

A M8\*16



B M8\*25



C M8\*35



D M8\*37



E Spacer



F Letter Opener



G Allen Key M5



H Allen Key M4



I Angle iron



J Foot









K Non-Slip Mat

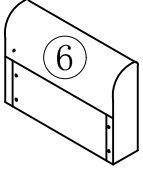
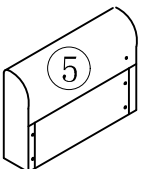
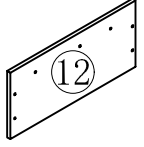
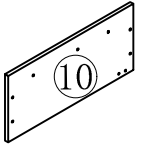
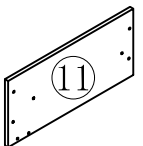
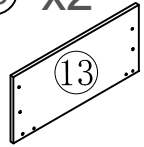
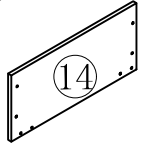
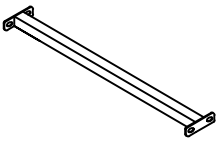
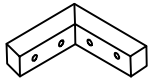

# TELLE

N657P421026

<p>⑥ -R x1</p> 	<p>⑤ -L x1</p> 	<p>⑫ x2</p> 	<p>⑩ x1</p> 
<p>⑪ x1</p> 	<p>⑬ x2</p> 	<p>⑭ x2</p> 	<p>⑳ x1</p> 
<p>⑳ x7</p> 	<p>㉑ x3</p> 	<p>㉒ x3</p> 	<p>① x20</p> 
<p>J x16</p>  <p>Foot</p>	<p>K x16</p>  <p>Non-Slip Mat</p>		

# TELLE



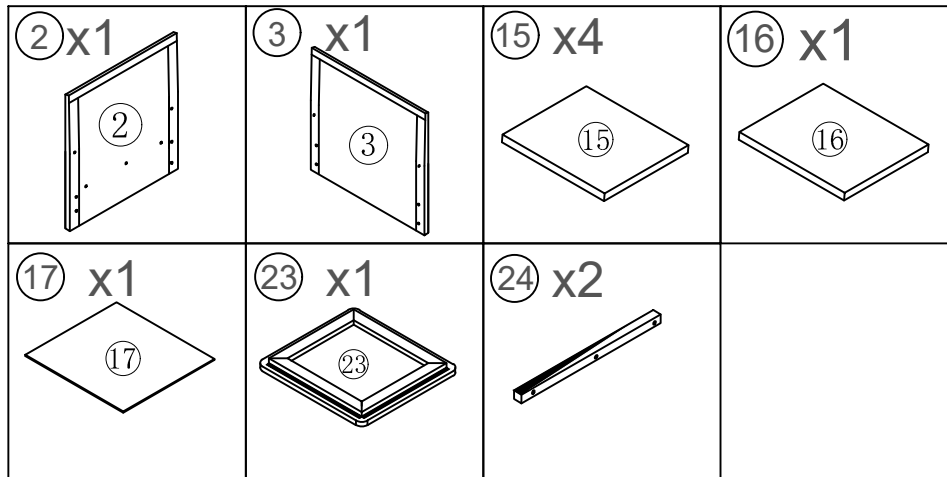



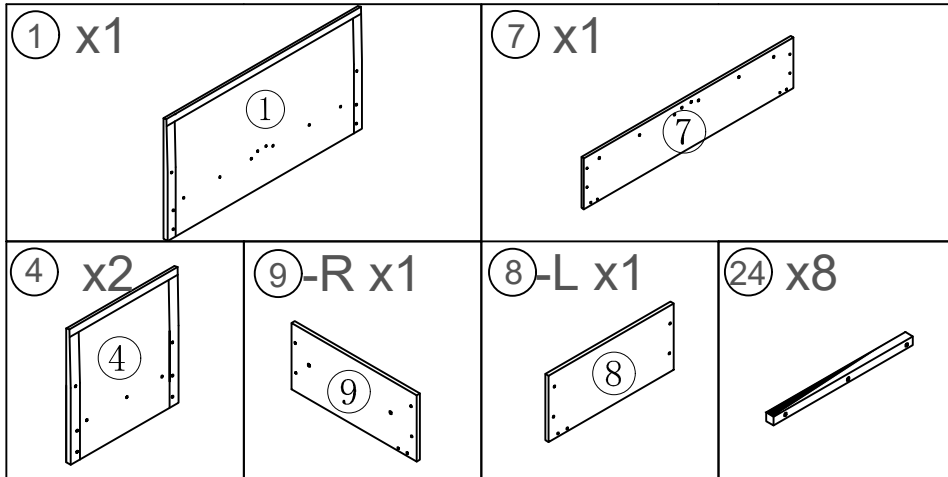

N657P421027



# TELLE

N657P421028



<p>A x88</p>  <p>M8*16</p>	<p>B x10</p>  <p>M8*25</p>	<p>C x28</p>  <p>M8*35</p>	<p>D x30</p>  <p>M8*37</p>
<p>E x2</p>  <p>Spacer</p>	<p>F x1</p>  <p>Letter Opener</p>	<p>G x1</p>  <p>Allen Key M5</p>	<p>H x1</p>  <p>Allen Key M4</p>

# TELLE

N657P421029

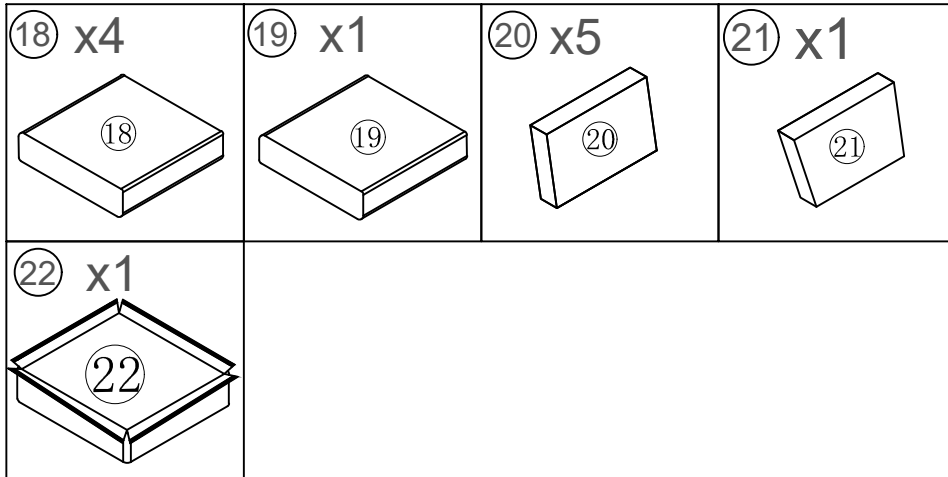

# 01

DE: Bitte montieren Sie die Seite mit dem Aufkleber oben.  
EN: Please assemble the side with the sticker on top  
FR: Veuillez assembler le côté avec l'autocollant sur le dessus.

D M8\*37  
 X6

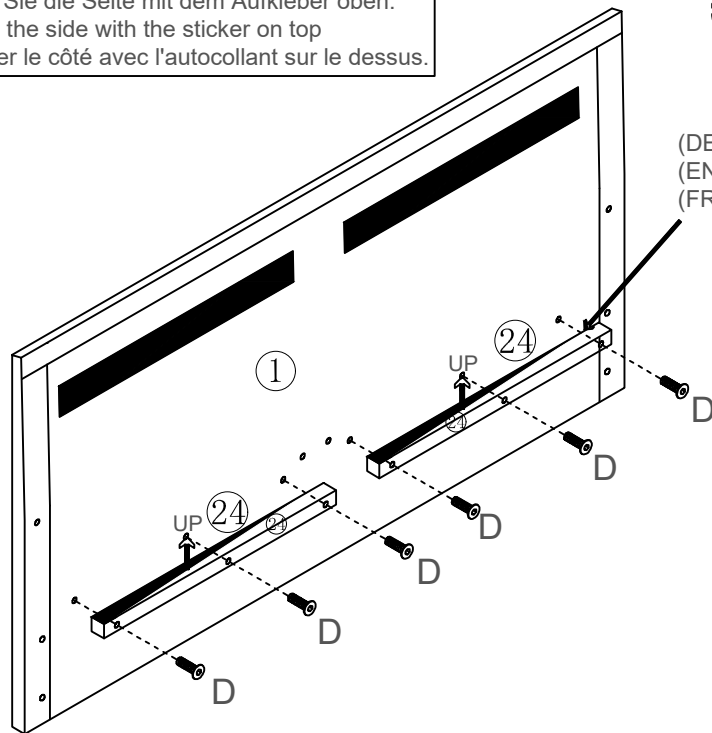

# 02

A M8\*16  
 X4

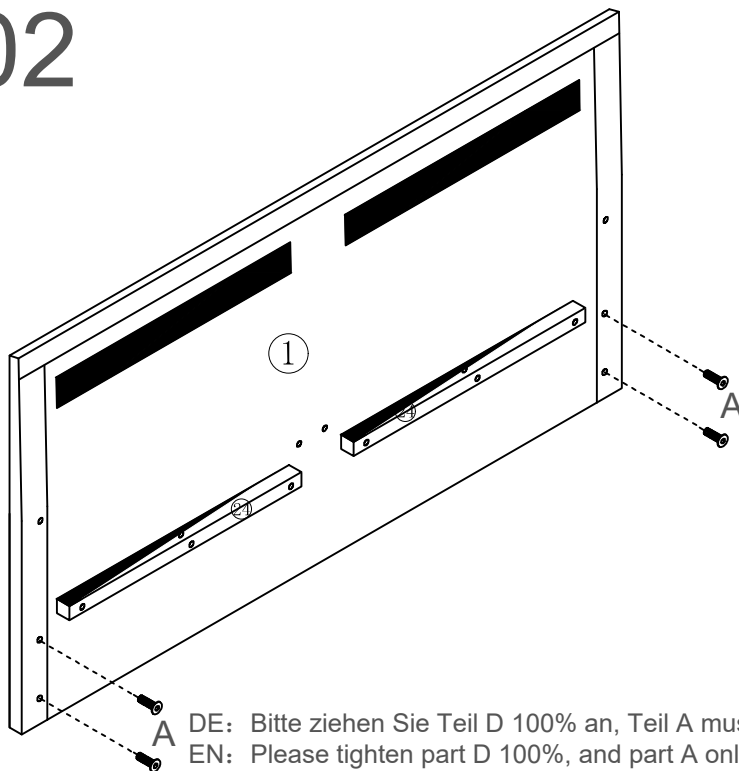

DE: Bitte ziehen Sie Teil D 100% an, Teil A muss nur 70% angezogen werden.  
EN: Please tighten part D 100%, and part A only needs to be tightened 70%.  
FR: Veuillez serrer la partie D à 100 % et la partie A ne doit être serrée qu'à 70 %.

# 03

DE: Bitte montieren Sie die Seite mit dem Aufkleber oben.  
EN: Please assemble the side with the sticker on top  
FR: Veuillez assembler le côté avec l'autocollant sur le dessus.

D M8\*37  
 X6

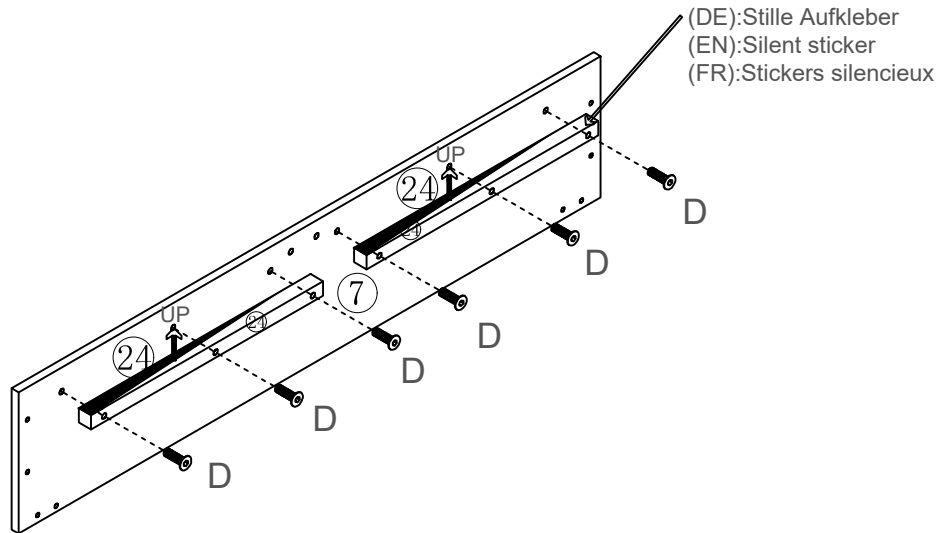

# 04

A M8\*16  
 X4

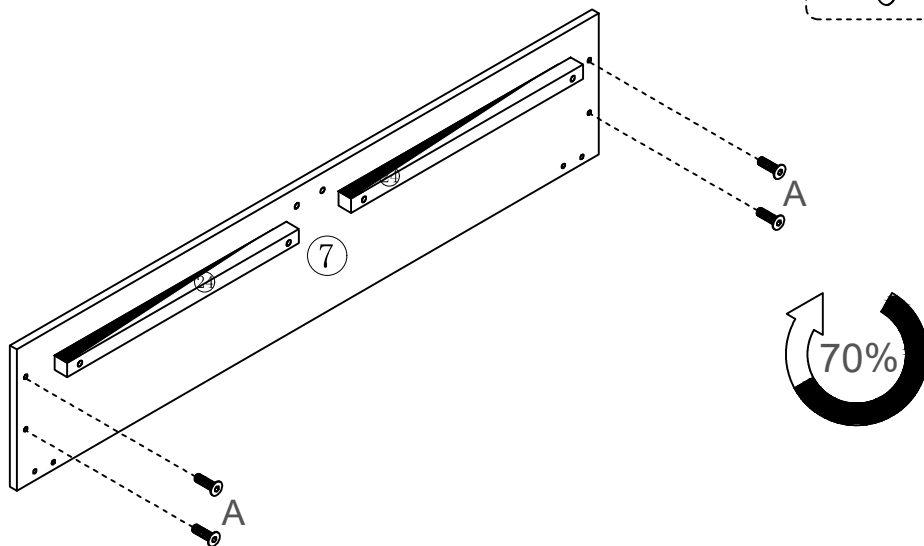

DE: Bitte ziehen Sie Teil D 100% an, Teil A muss nur 70% angezogen werden.  
EN: Please tighten part D 100%, and part A only needs to be tightened 70%.  
FR: Veuillez serrer la partie D à 100 % et la partie A ne doit être serrée qu'à 70 %.

# 05

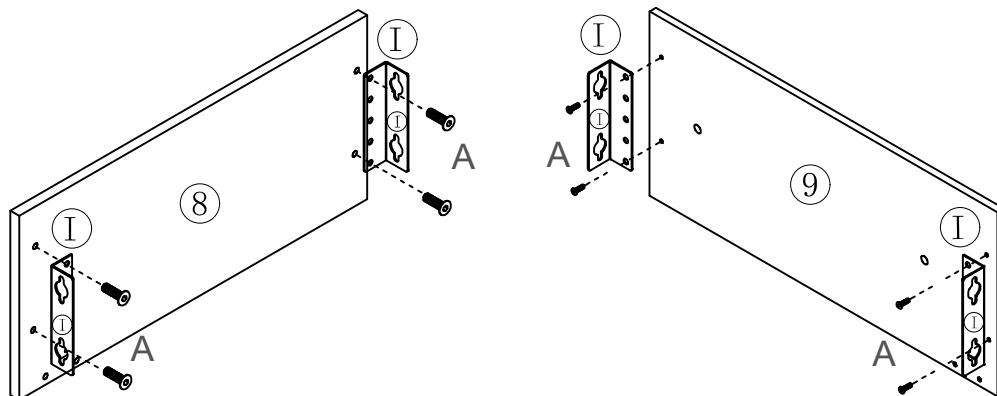
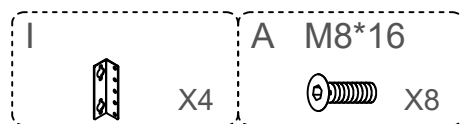

# 06

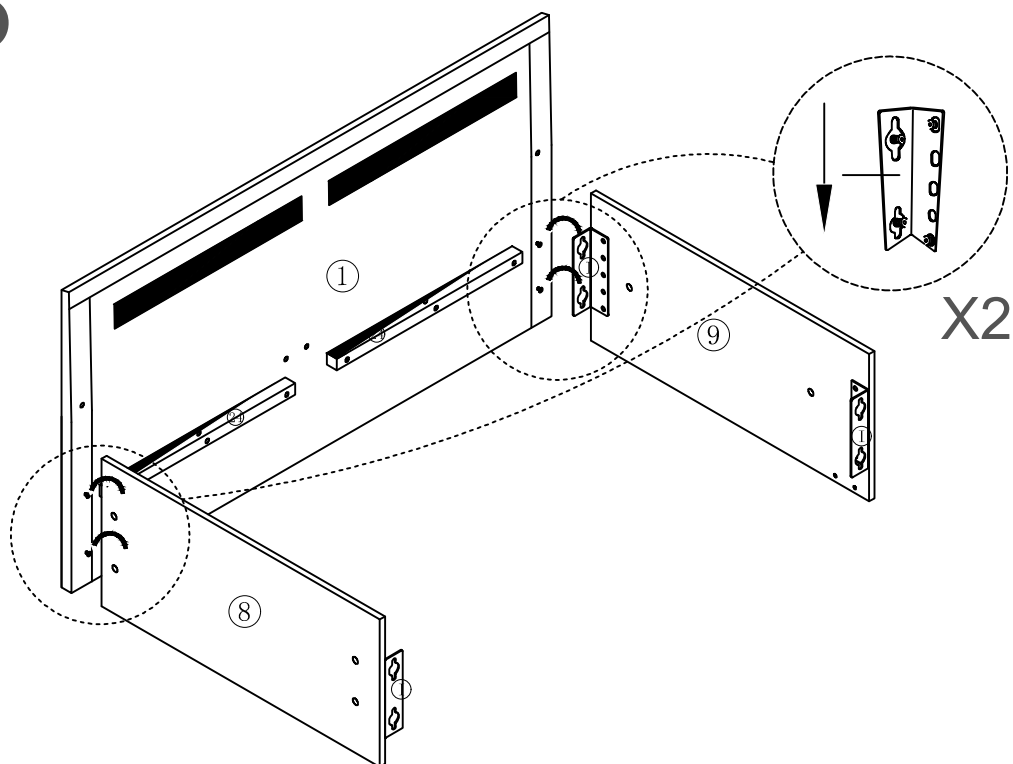

07

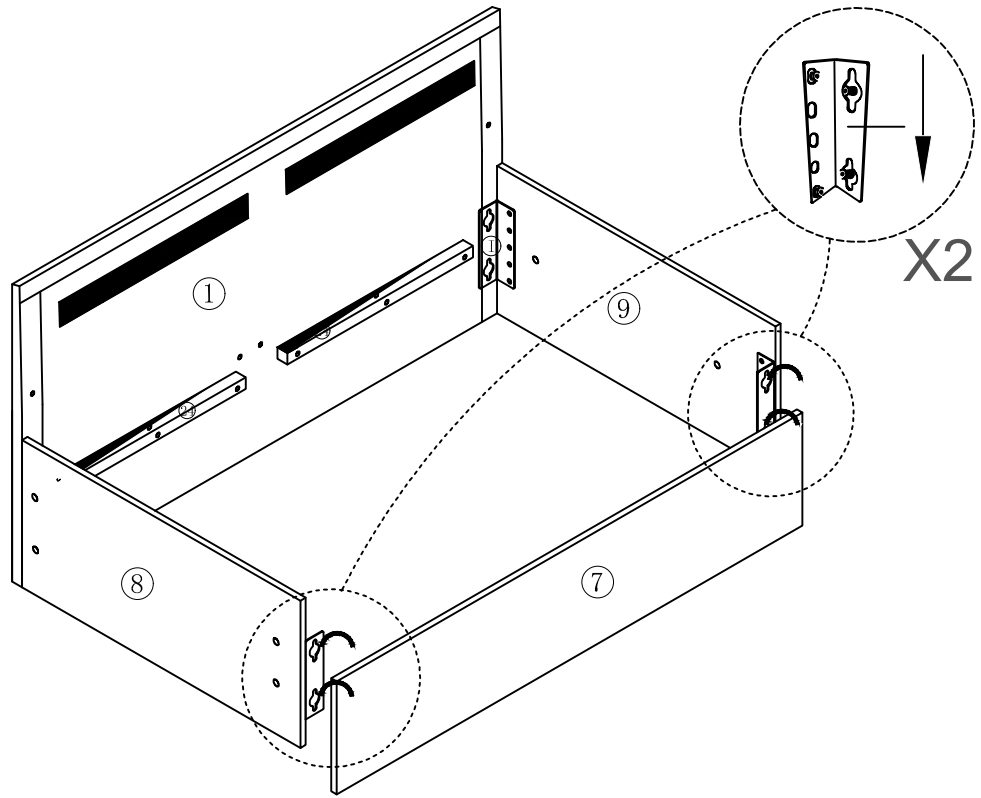

08

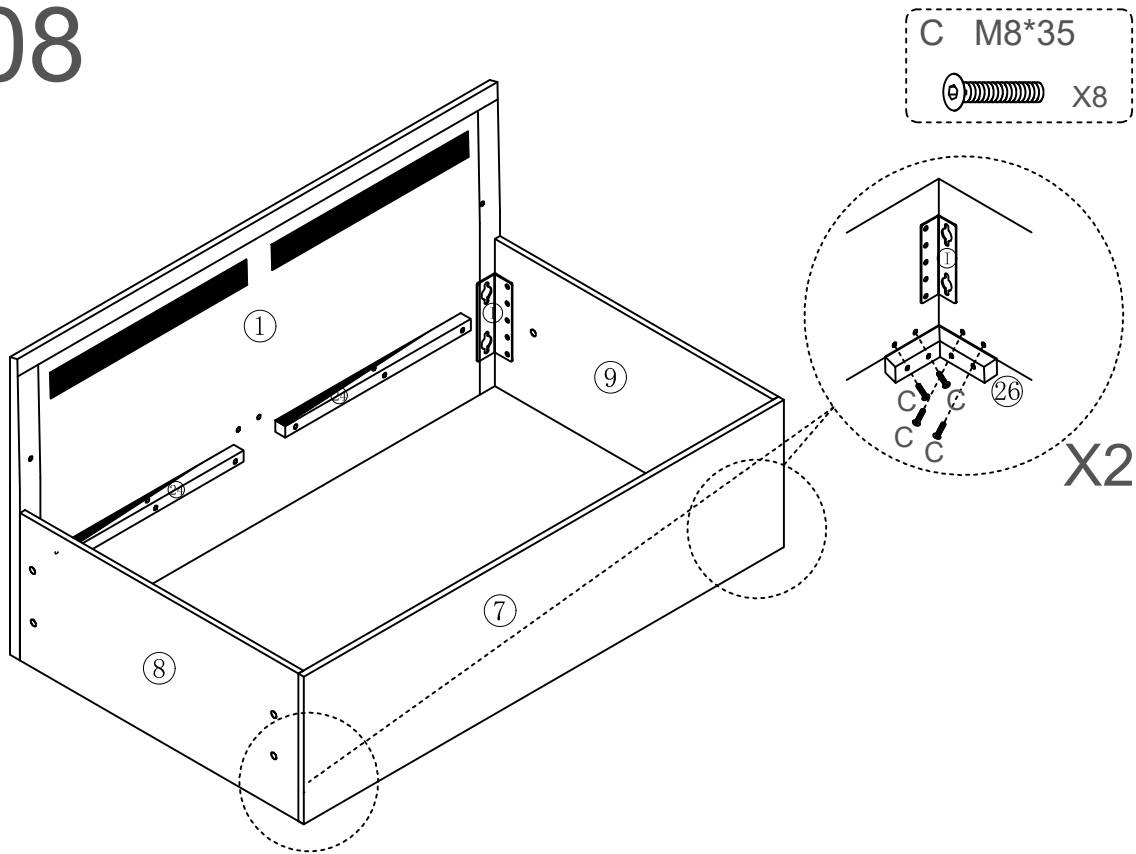

# 09

A M8\*16  
 X4

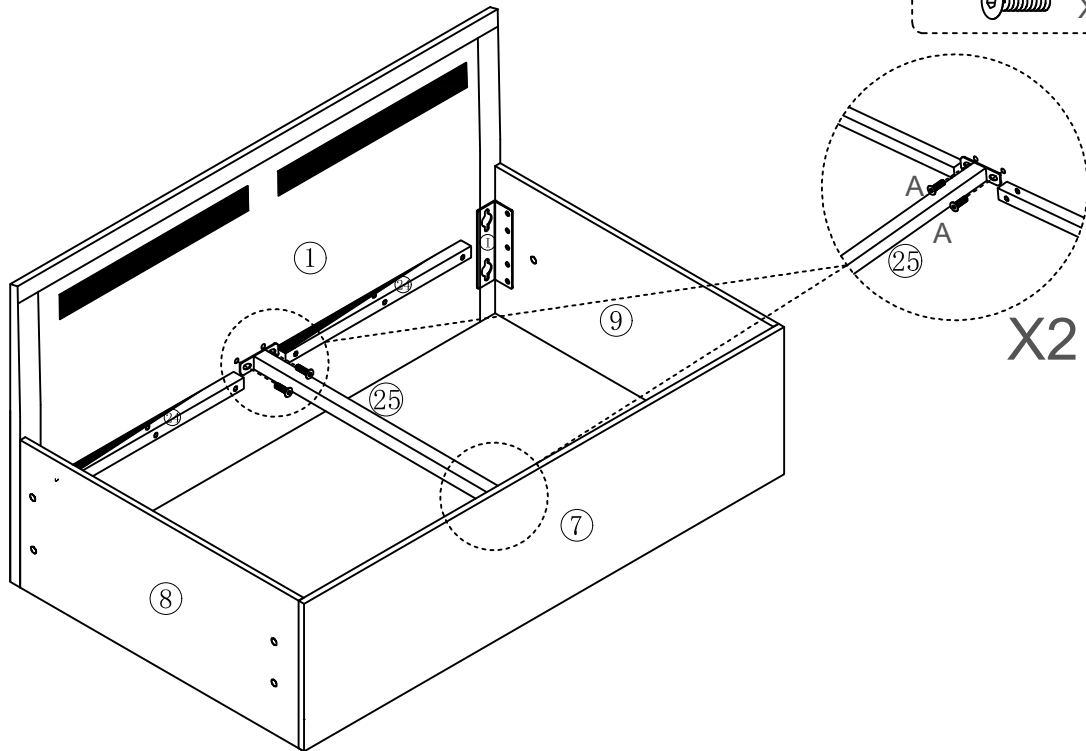

# 10

J X4 K X4

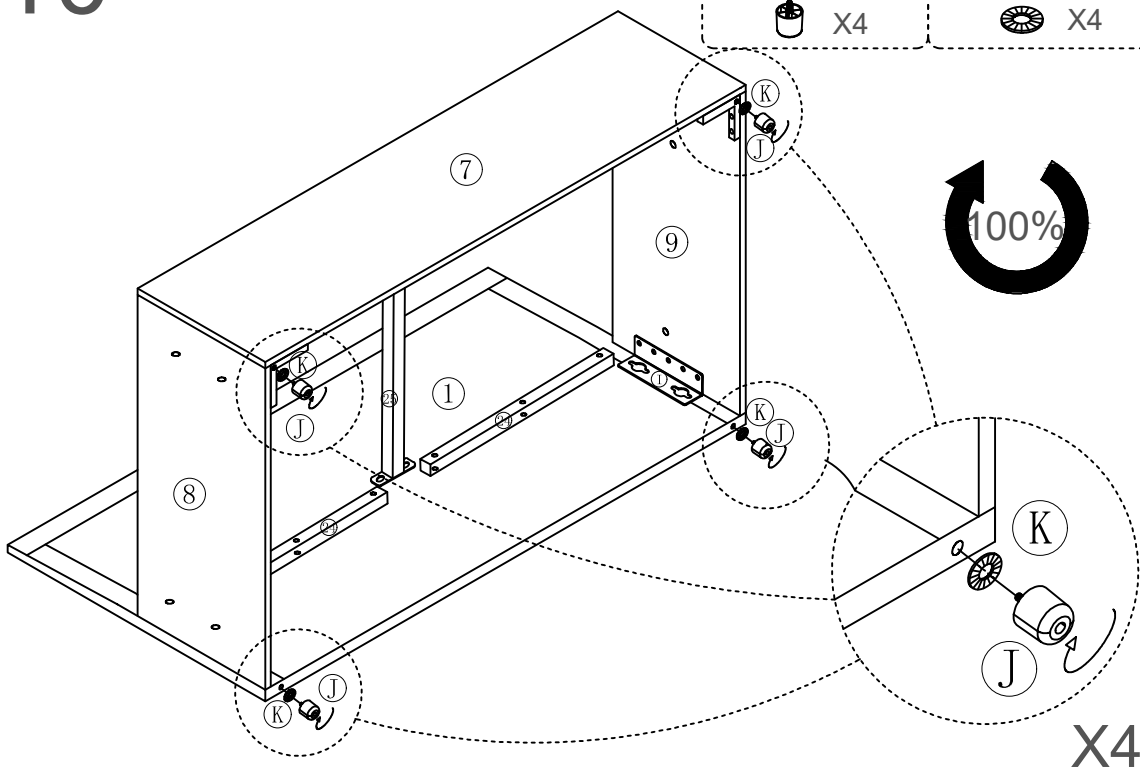



# 11

DE: Bitte montieren Sie die Seite mit dem Aufkleber oben.  
EN: Please assemble the side with the sticker on top  
FR: Veuillez assembler le côté avec l'autocollant sur le dessus.

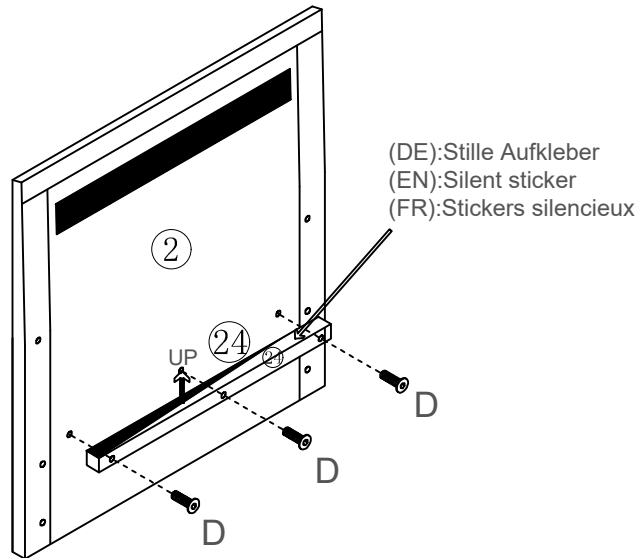
D M8\*37  
 X3



# 12

I A M8\*16  
 X1  X4

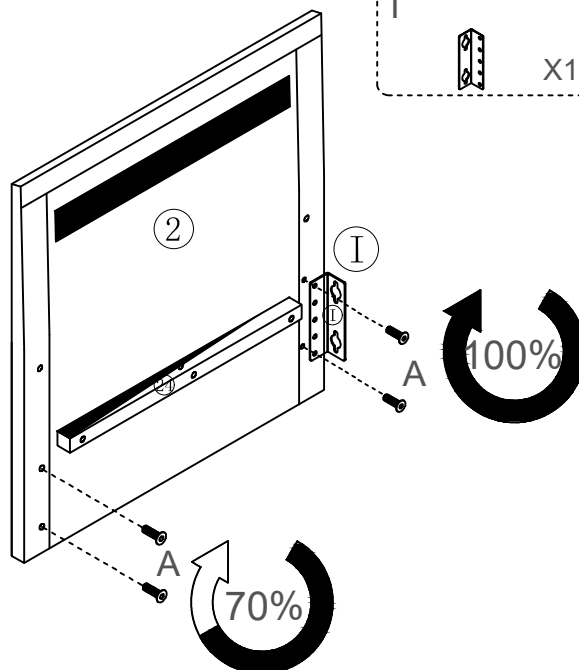

DE: Bitte ziehen Sie Teil D 100% an, Teil A muss nur 70% angezogen werden.  
EN: Please tighten part D 100%, and part A only needs to be tightened 70%.  
FR: Veuillez serrer la partie D à 100 % et la partie A ne doit être serrée qu'à 70 %.

# 13

DE: Bitte montieren Sie die Seite mit dem Aufkleber oben.  
EN: Please assemble the side with the sticker on top  
FR: Veuillez assembler le côté avec l'autocollant sur le dessus.

D M8\*37  
 X3

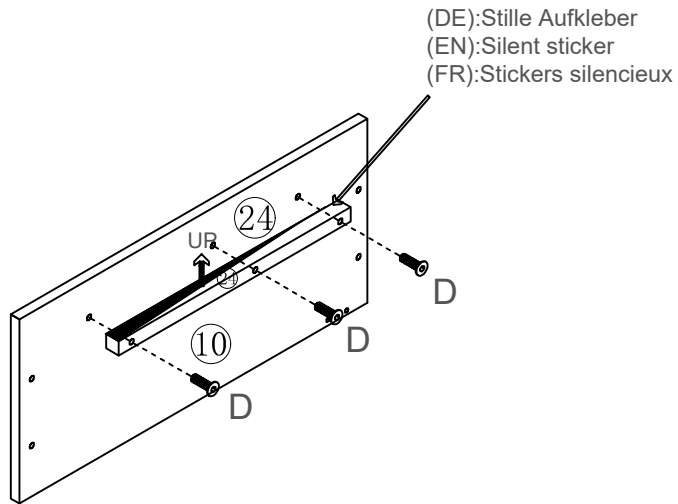

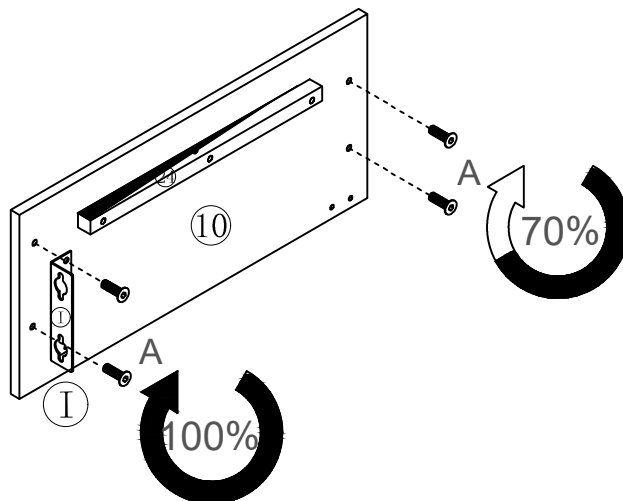

# 14

I X1  
A M8\*16  
 X4



DE: Bitte ziehen Sie Teil D 100% an, Teil A muss nur 70% angezogen werden.  
EN: Please tighten part D 100%, and part A only needs to be tightened 70%.  
FR: Veuillez serrer la partie D à 100 % et la partie A ne doit être serrée qu'à 70 %.

# 15

I	A M8*16
	
X2	X4

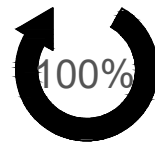
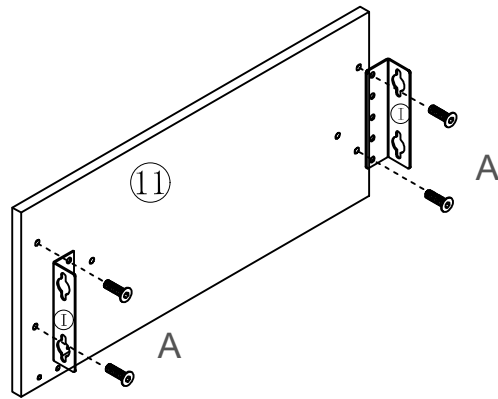

# 16

A M8*16	
	X4

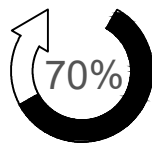
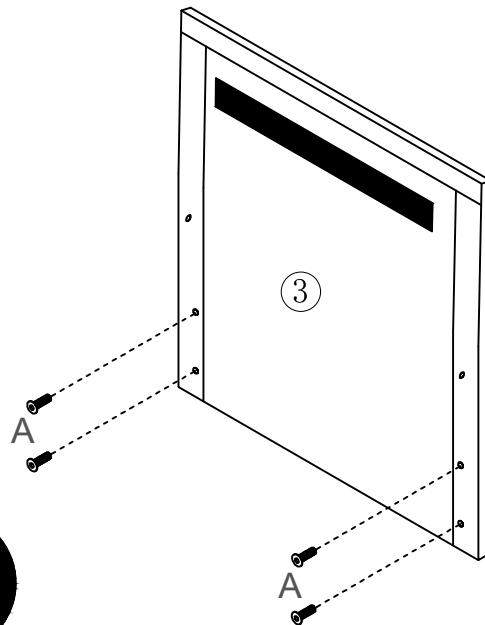

17

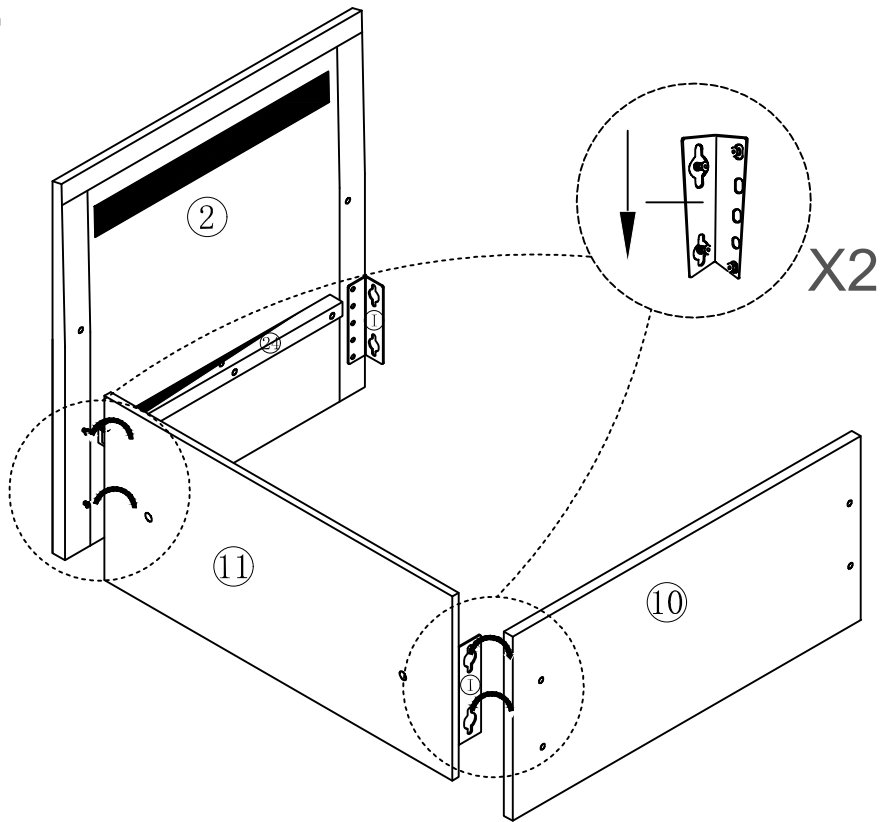

18

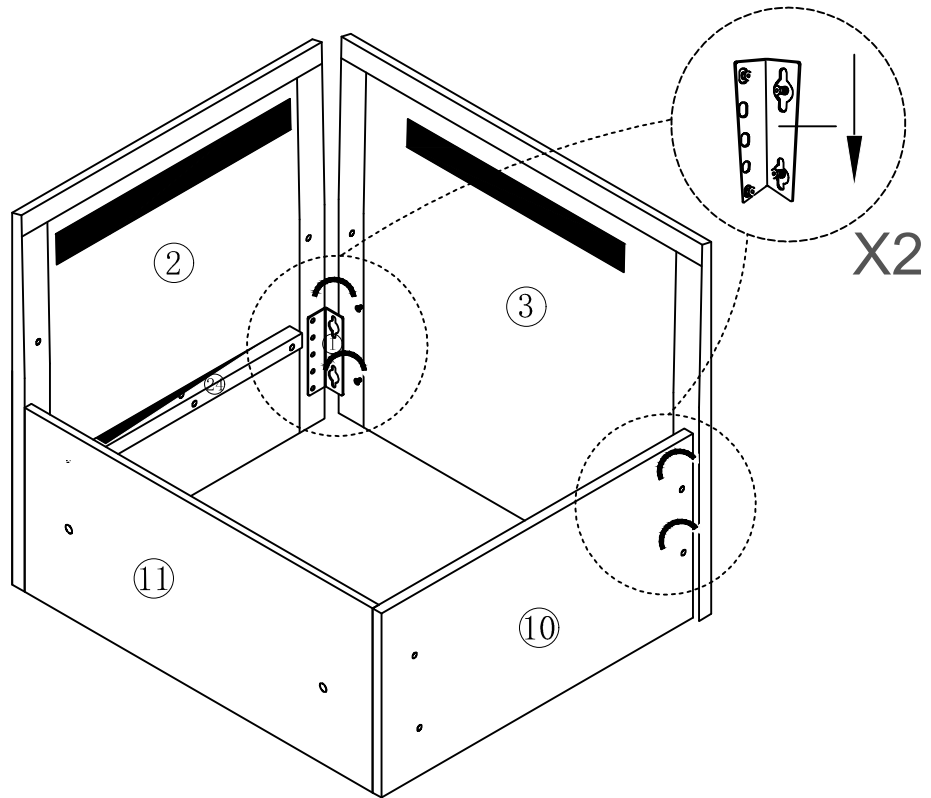

# 19

C M8\*35

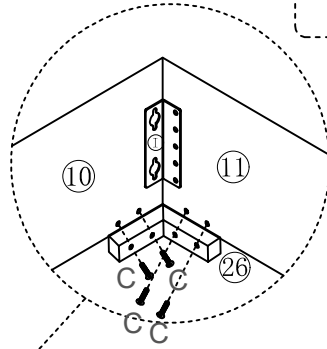
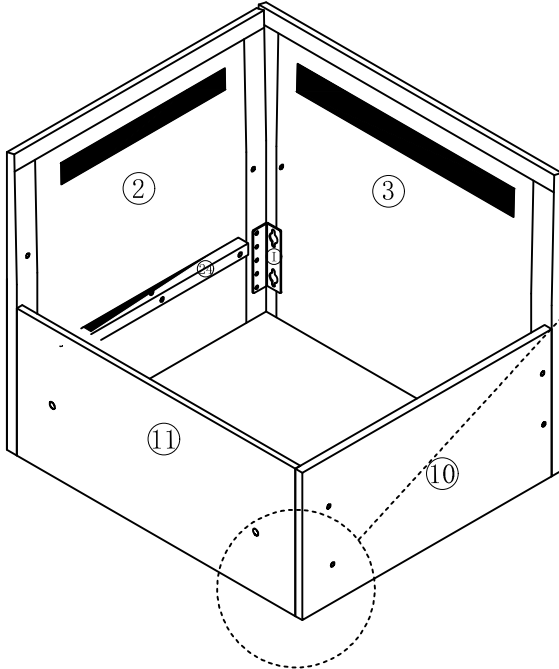

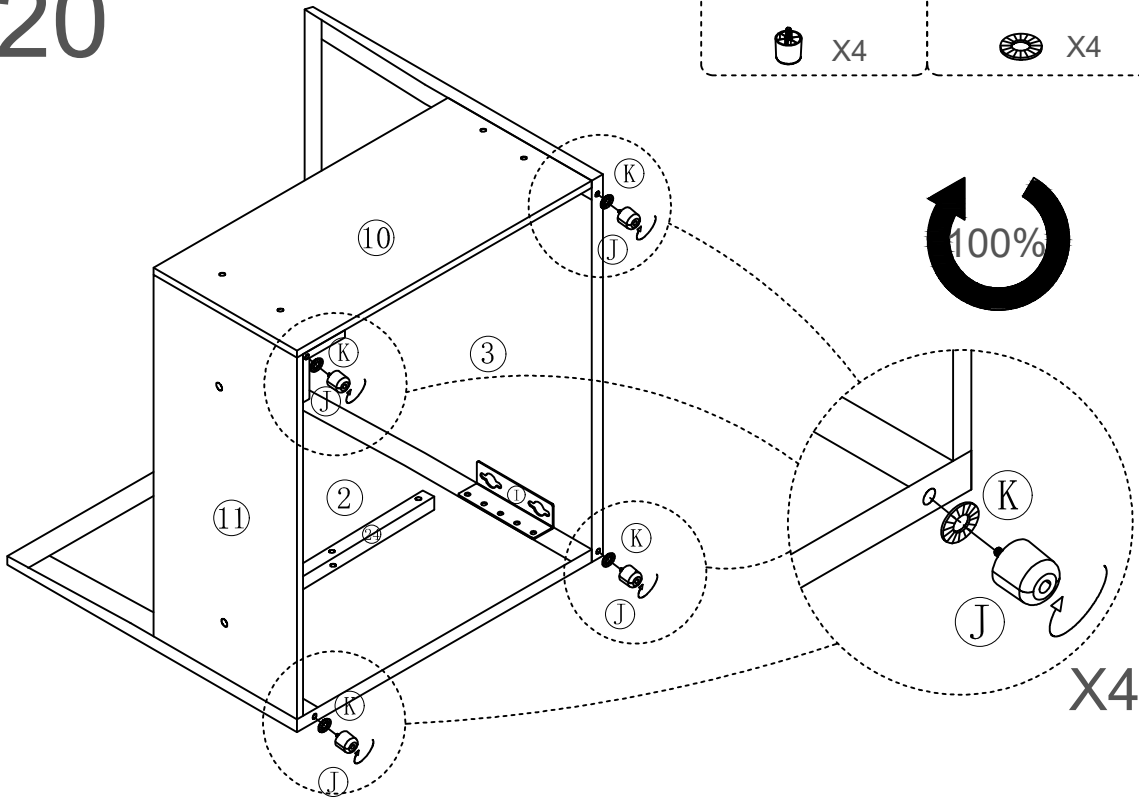

# 20

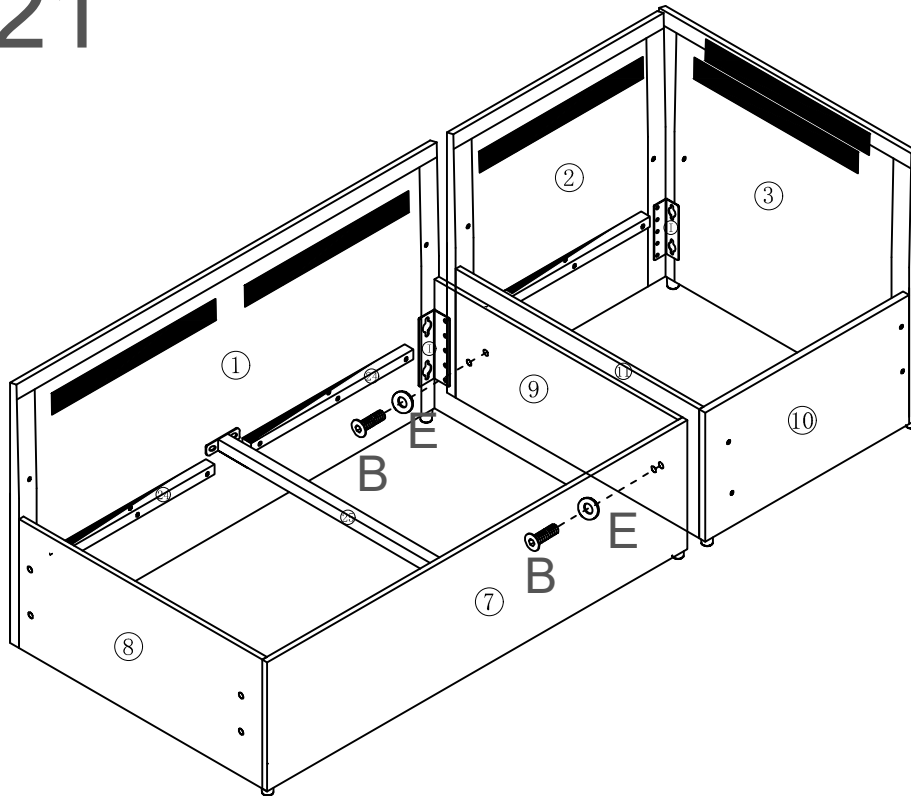

# 21



- B M8\*25  
 X2
- E Spacer  
 X2

# 22

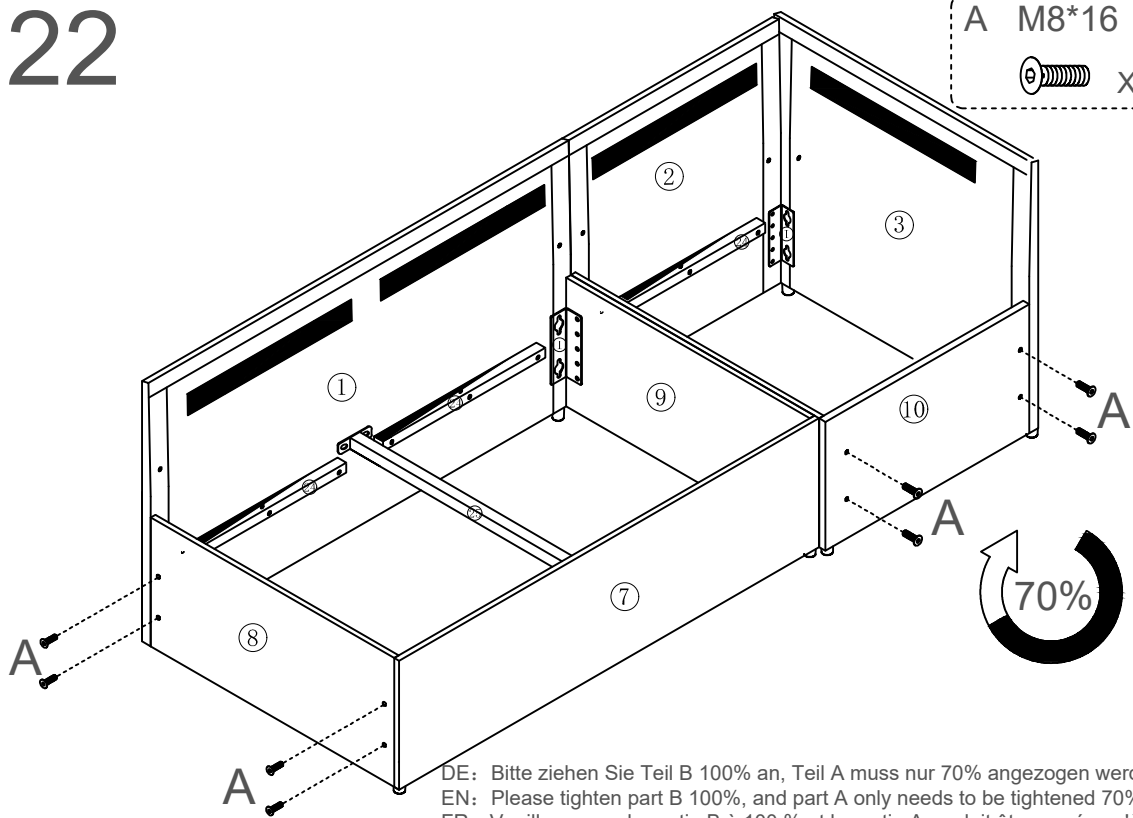

- A M8\*16  
 X8

DE: Bitte ziehen Sie Teil B 100% an, Teil A muss nur 70% angezogen werden.  
 EN: Please tighten part B 100%, and part A only needs to be tightened 70%.  
 FR: Veuillez serrer la partie B à 100 % et la partie A ne doit être serrée qu'à 70 %.

# 23

B M8\*25  
 X8

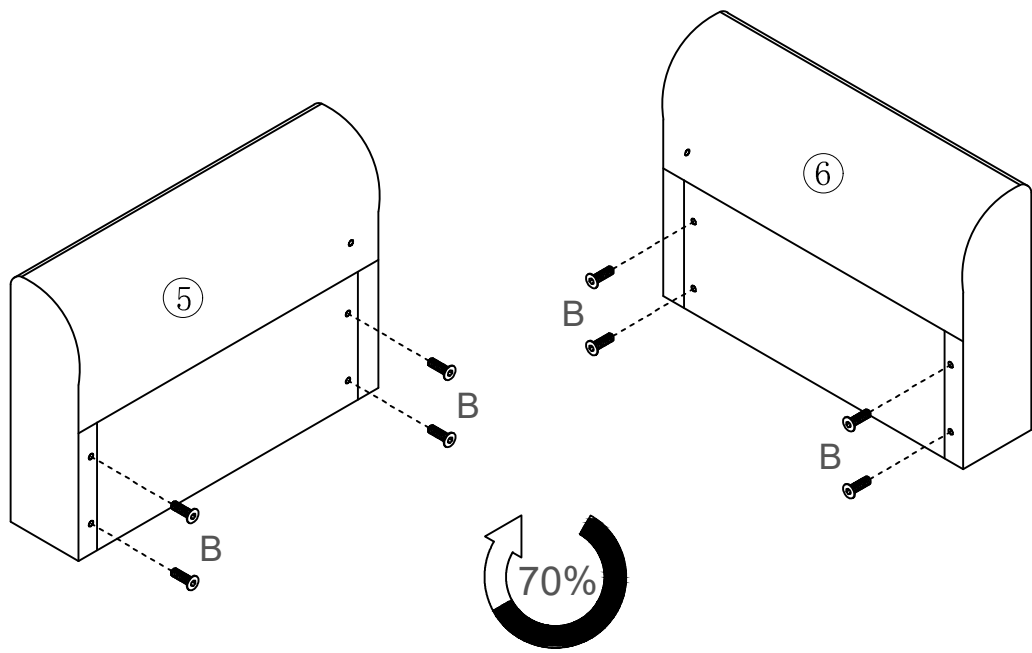

# 24

J X4      K X4

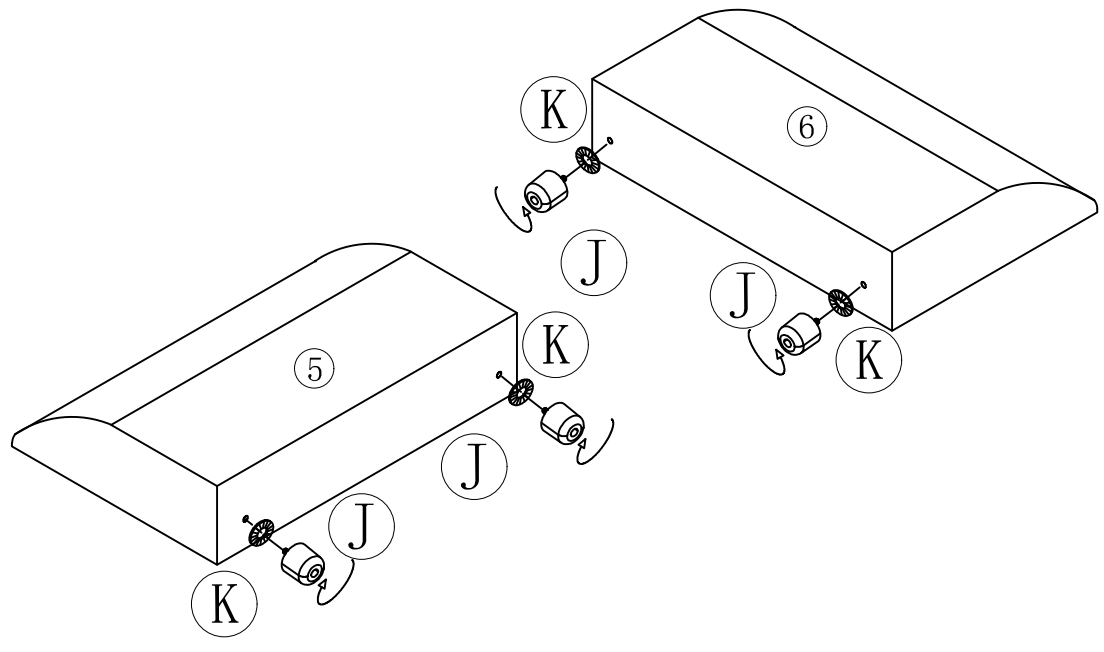

# 25

DE: Bitte montieren Sie die Seite mit dem Aufkleber oben.  
EN: Please assemble the side with the sticker on top  
FR: Veuillez assembler le côté avec l'autocollant sur le dessus.

D M8\*37  
 X6

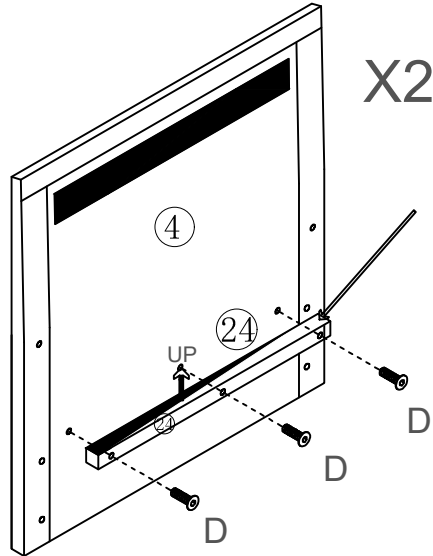

# 26

I X4  
A M8\*16  
 X8

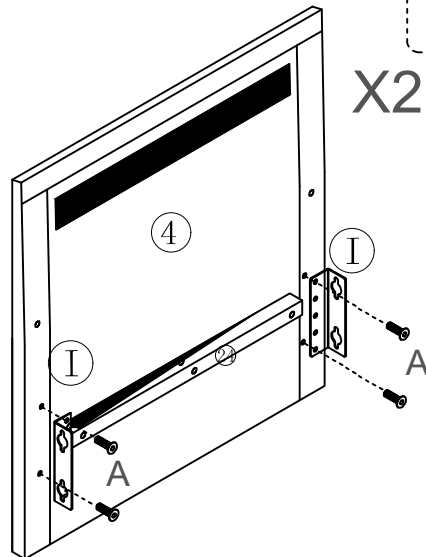

# 27

DE: Bitte montieren Sie die Seite mit dem Aufkleber oben.  
EN: Please assemble the side with the sticker on top  
FR: Veuillez assembler le côté avec l'autocollant sur le dessus.

D M8\*37  
 X6

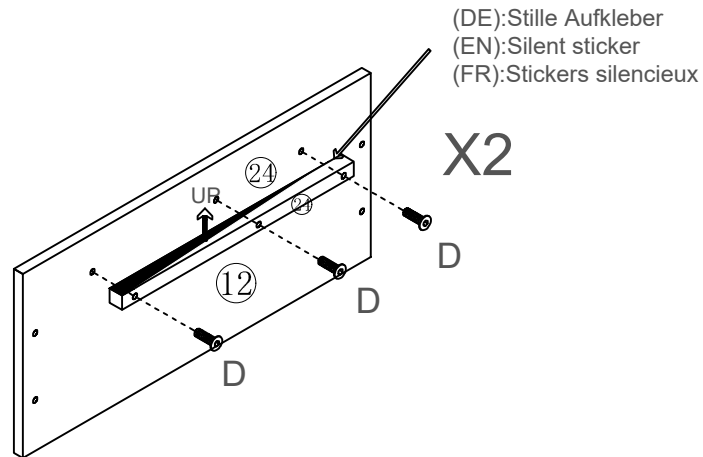

# 28

I X4  
A M8\*16  
 X8

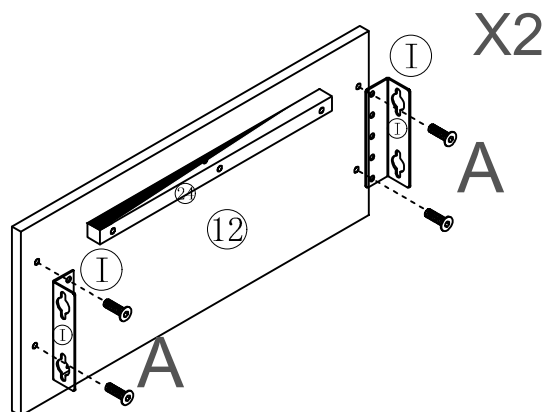

29

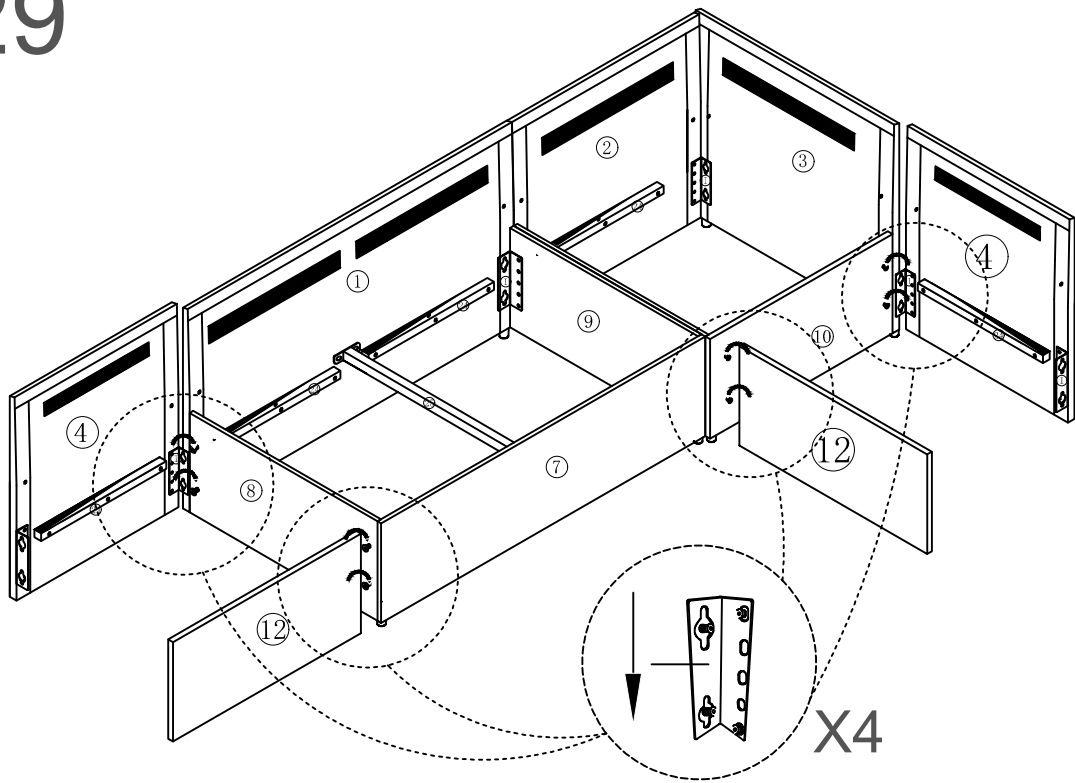

30

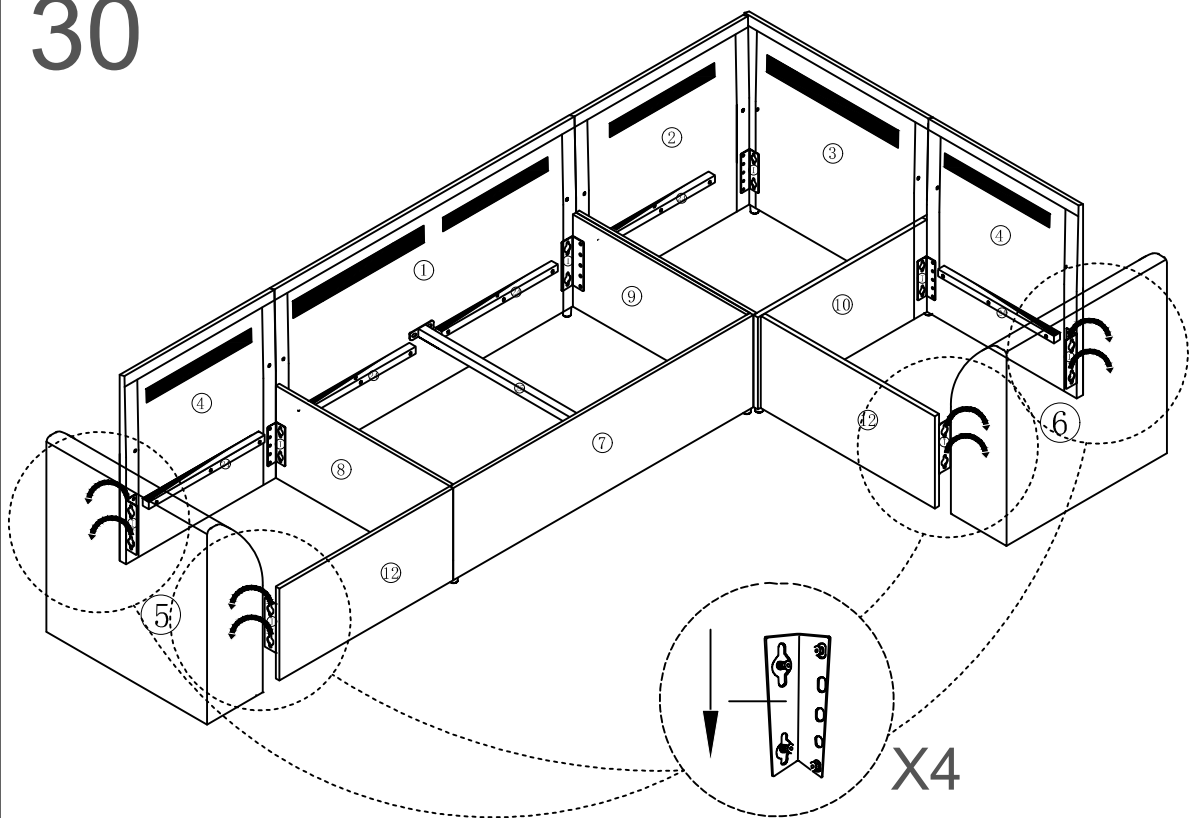

# 31

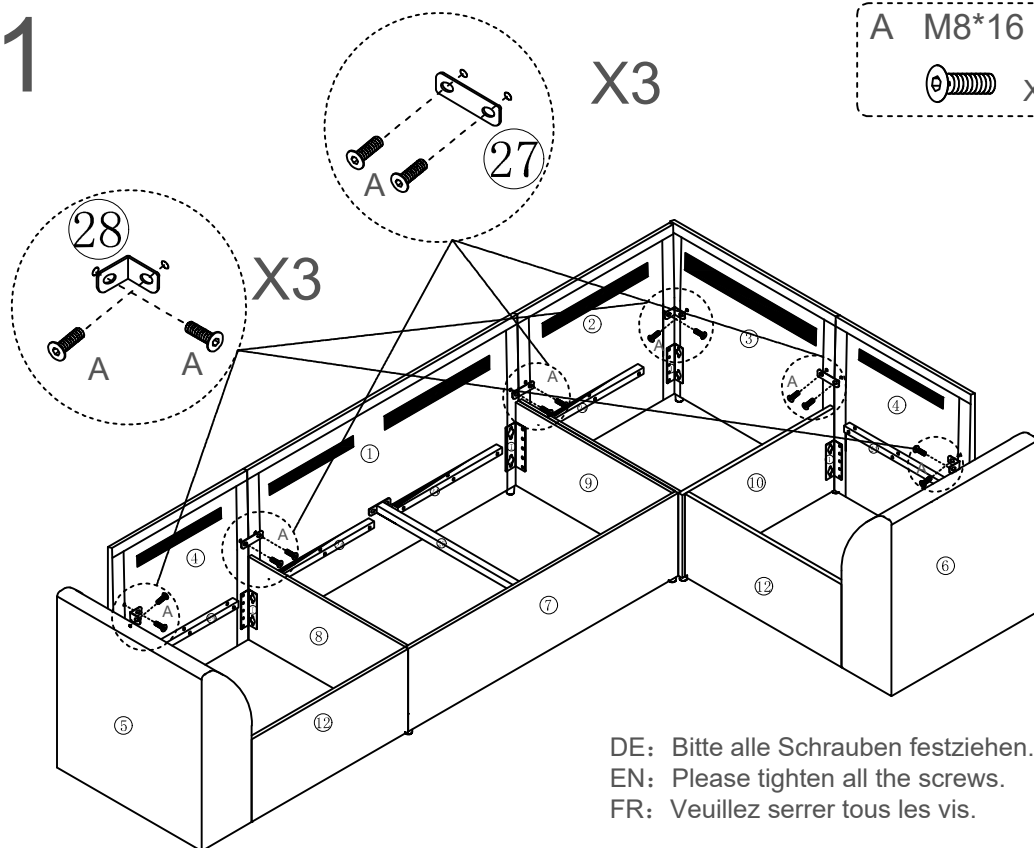

# 32

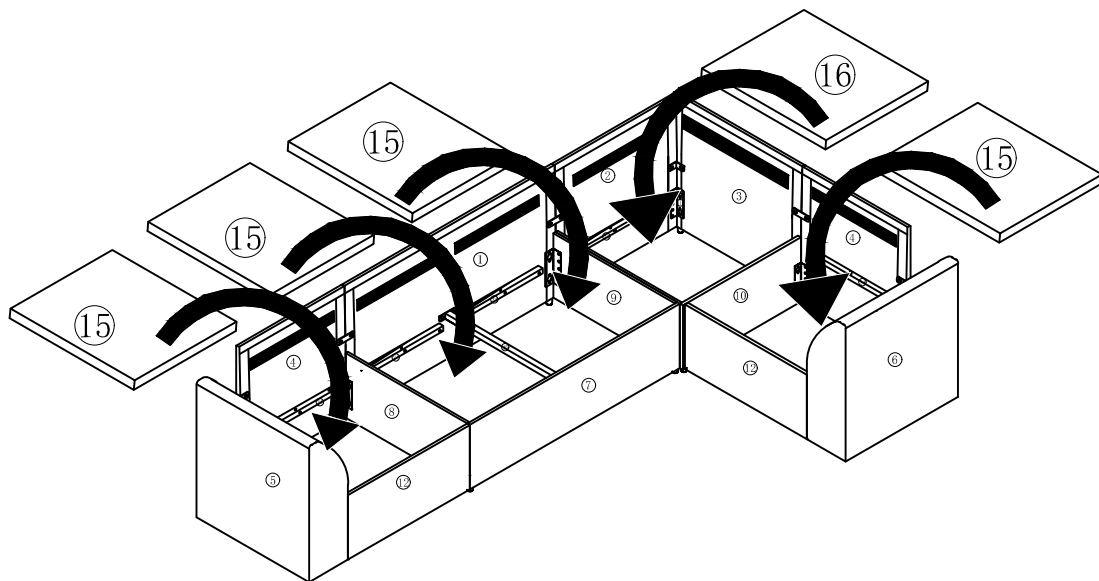

# 33

DE: Riss alle Stoffstreifen von den Teilen 1, 2, 3 und 4 ab.  
EN: Tear off all the fabric strips on components No. 1, 2, 3 and 4.  
FR: Retirez tous les bandes de tissu des pièces 1, 2, 3 et 4.

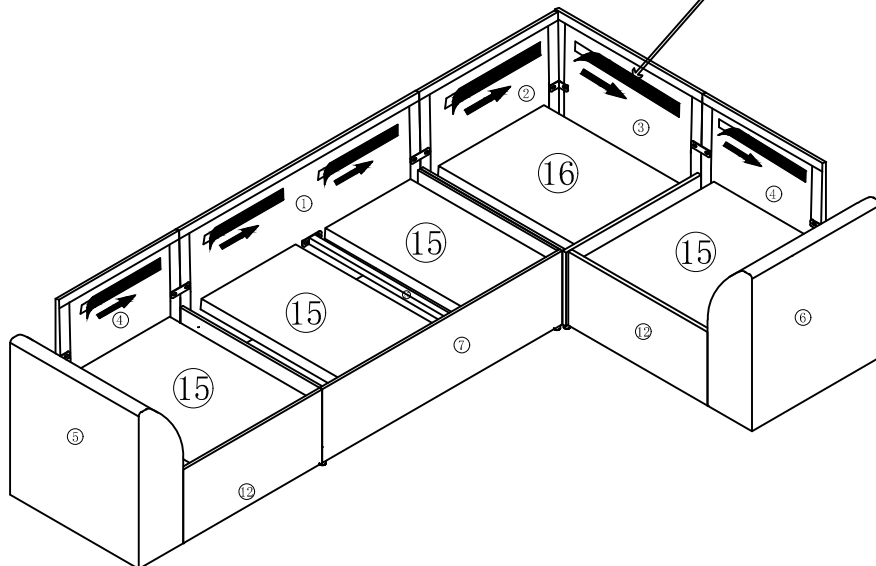

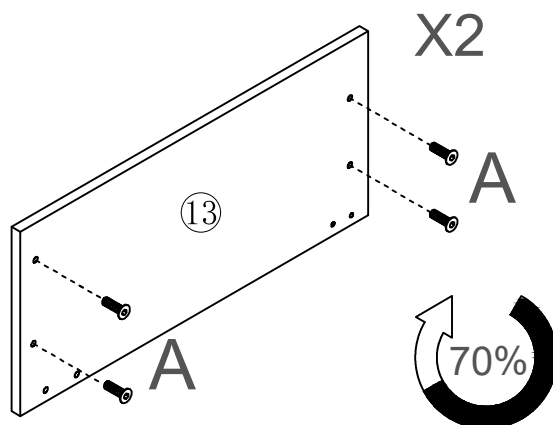

# 34

A M8\*16  
 X8



# 35

I	A
	M8*16
X4	 X8

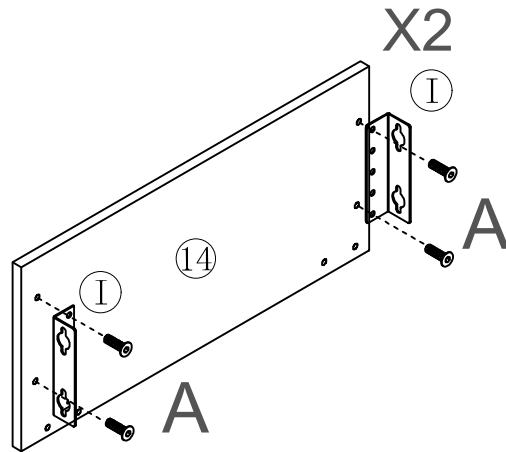

# 36

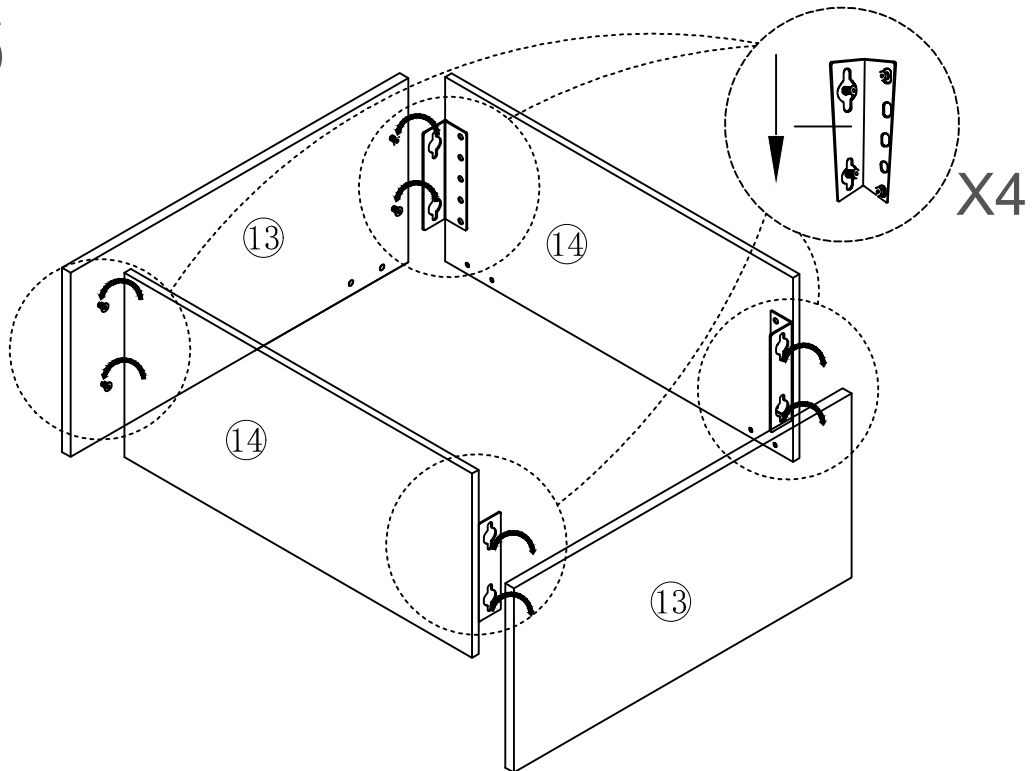

# 37

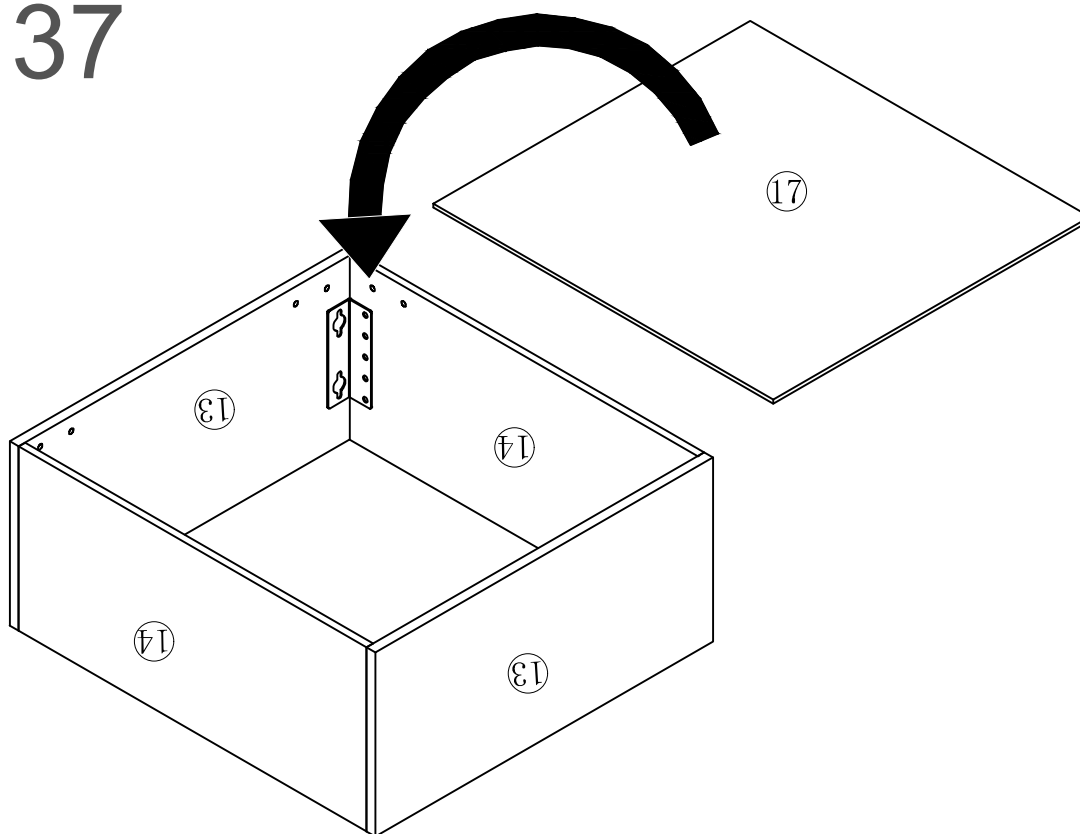

# 38

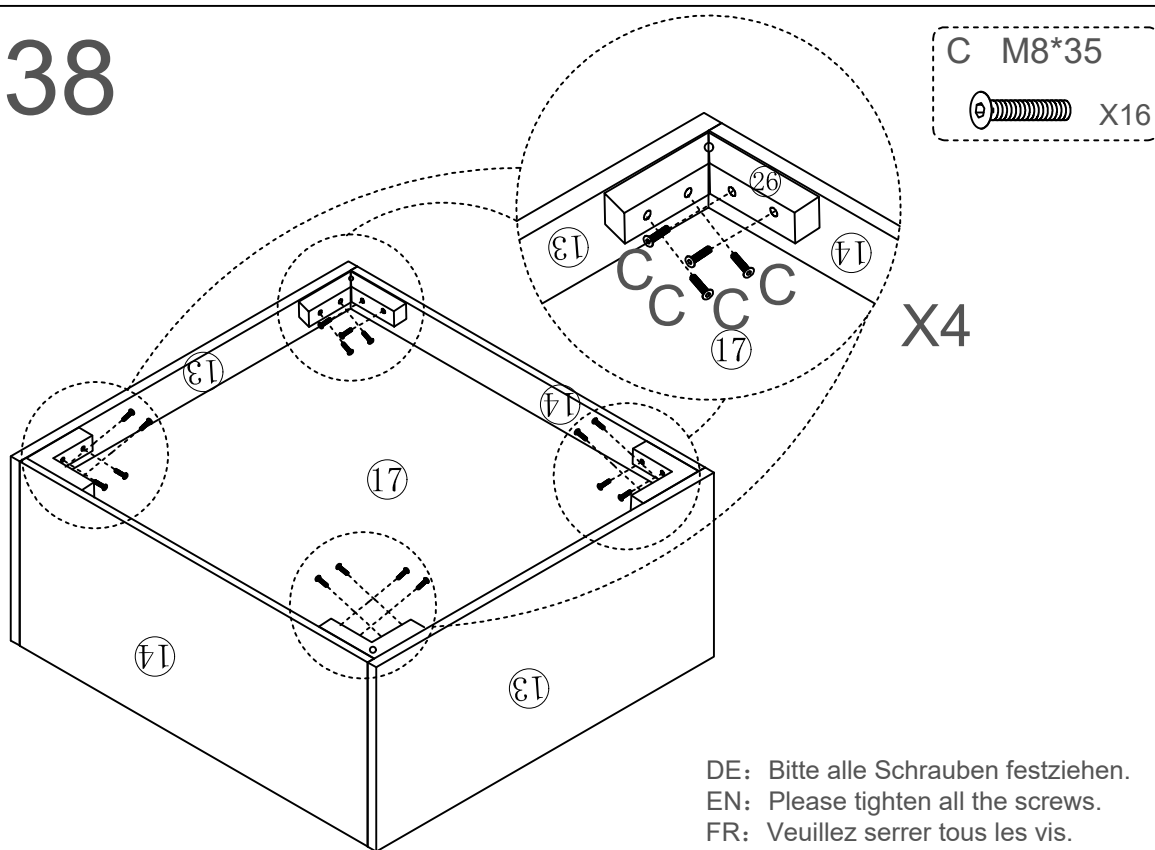

DE: Bitte alle Schrauben festziehen.  
EN: Please tighten all the screws.  
FR: Veuillez serrer tous les vis.

# 39

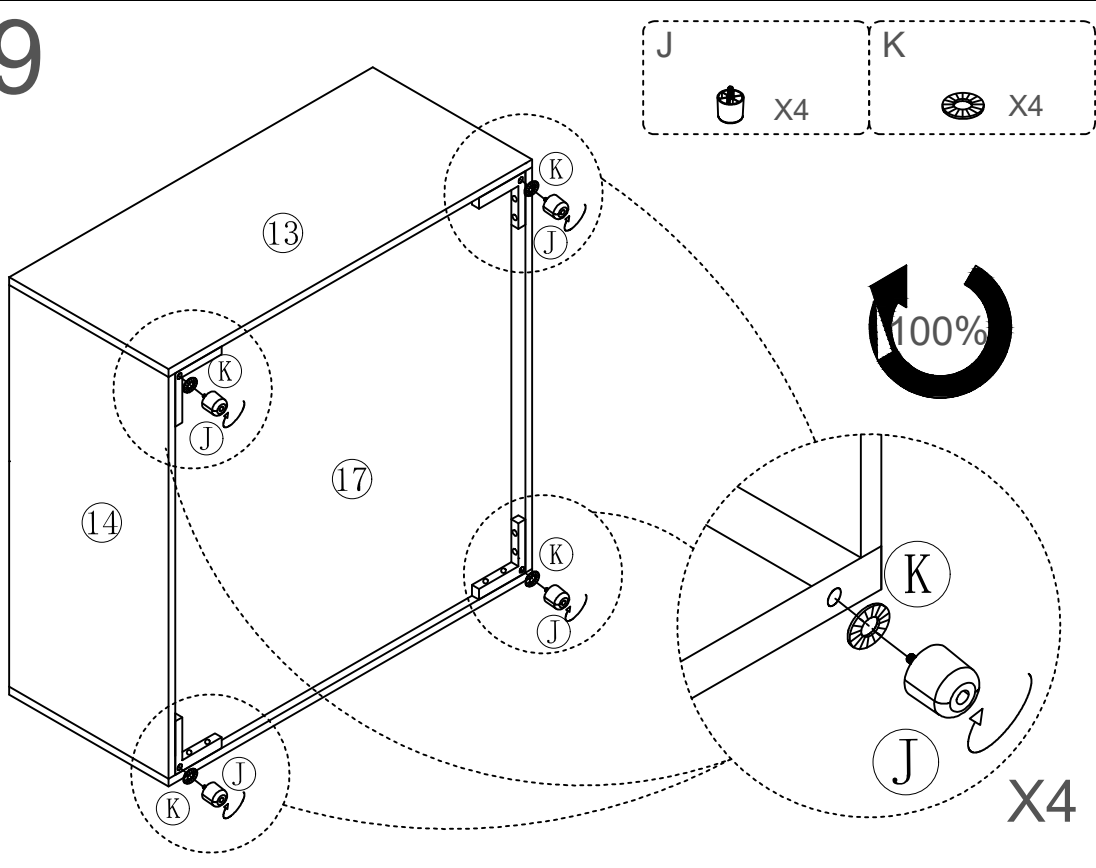

# 40

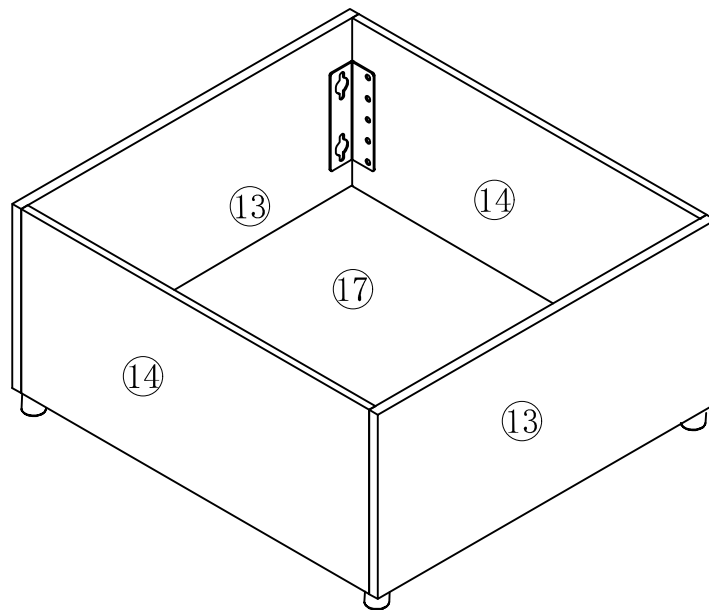

41

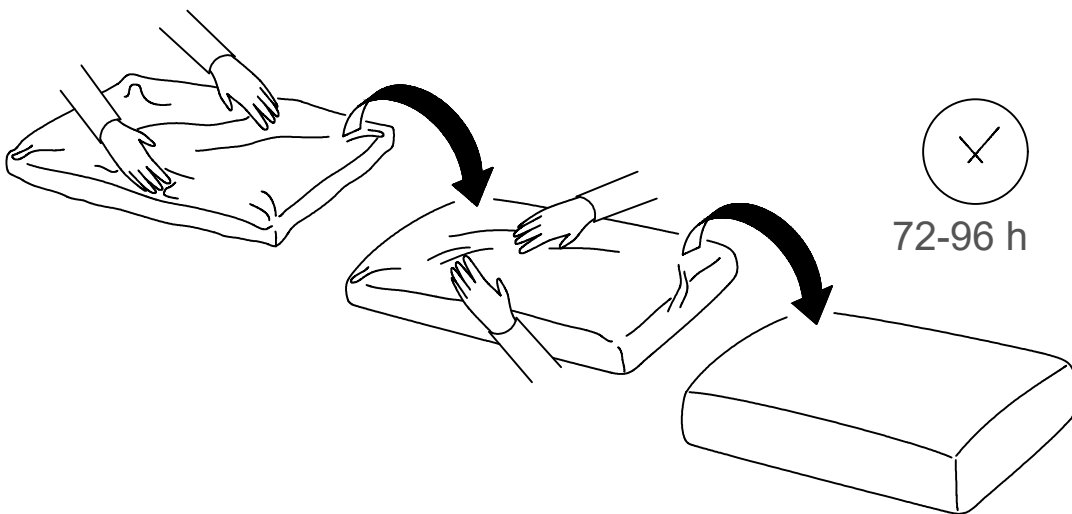
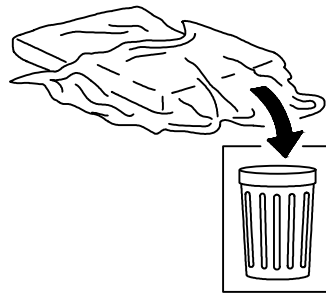
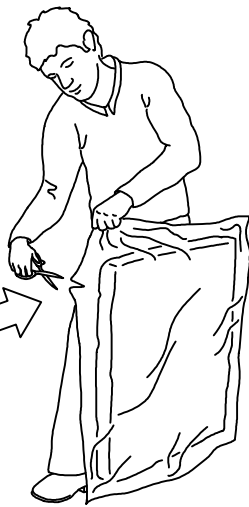
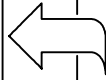
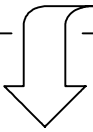
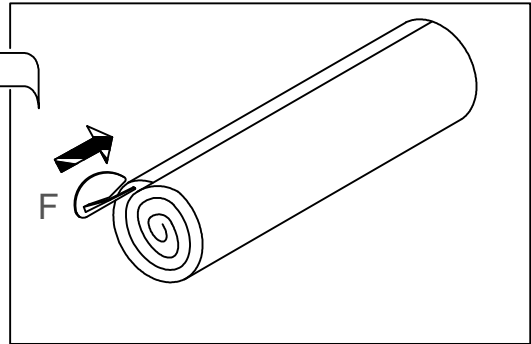
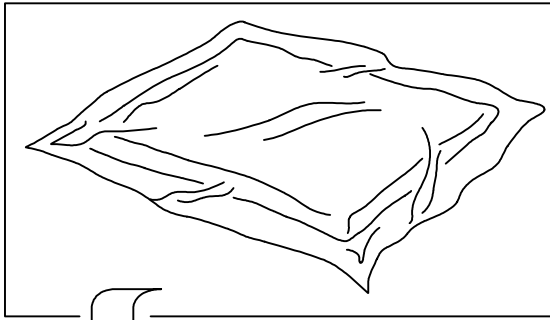

42

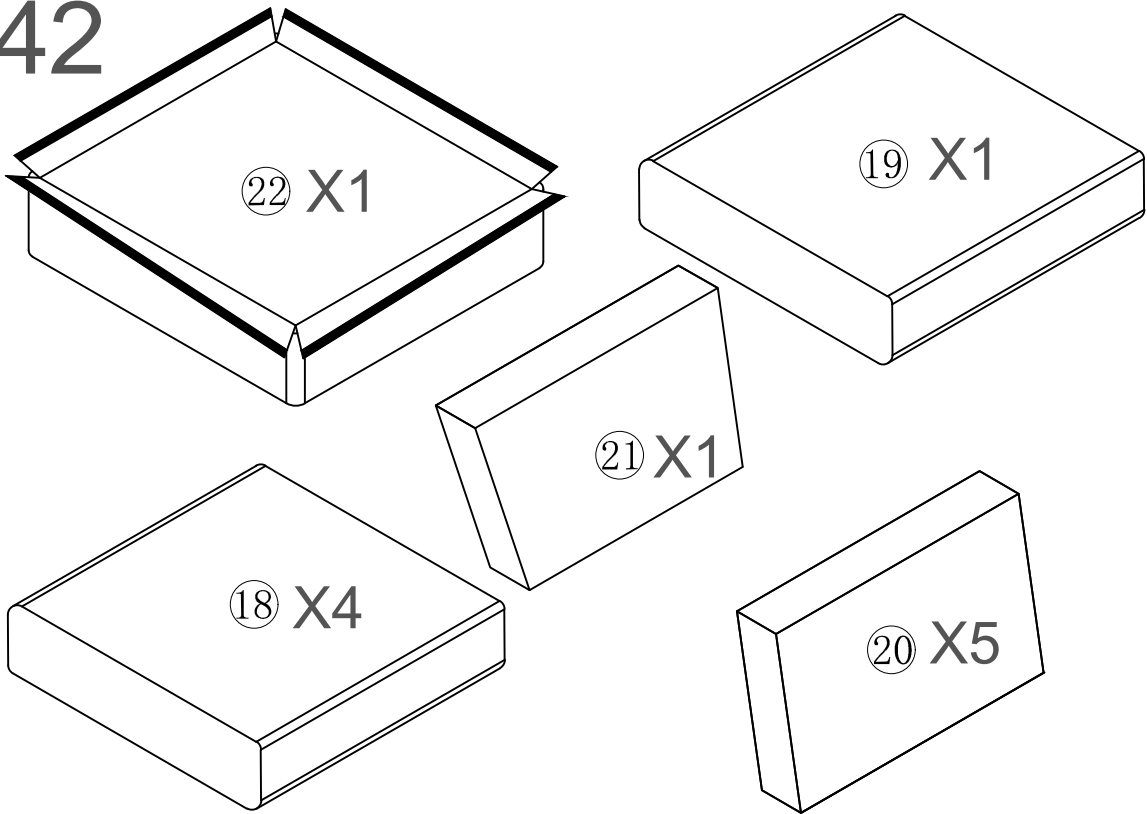

43

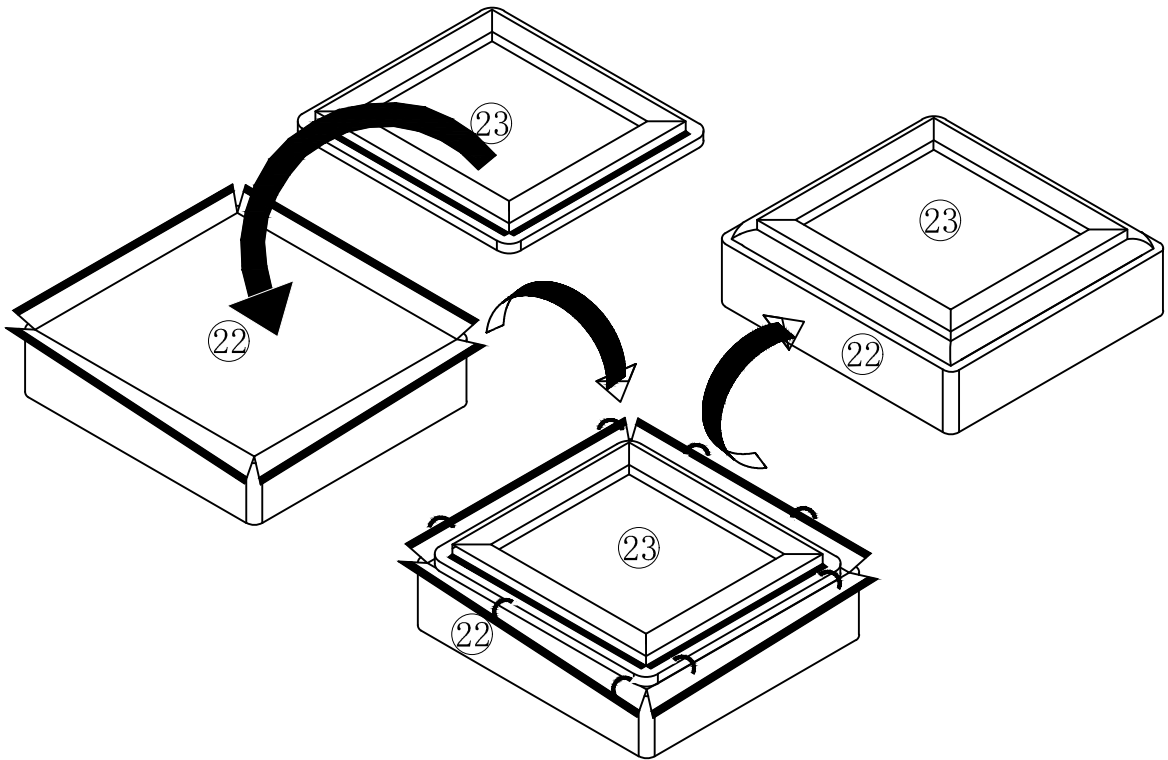

44

