

Manuel d'instructions/Instruction Manual/
Bedienungsanleitung/Manual de instrucciones/
Manuale di istruzioni/Handleiding

PRIMO

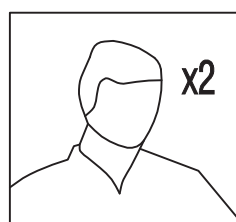

x2

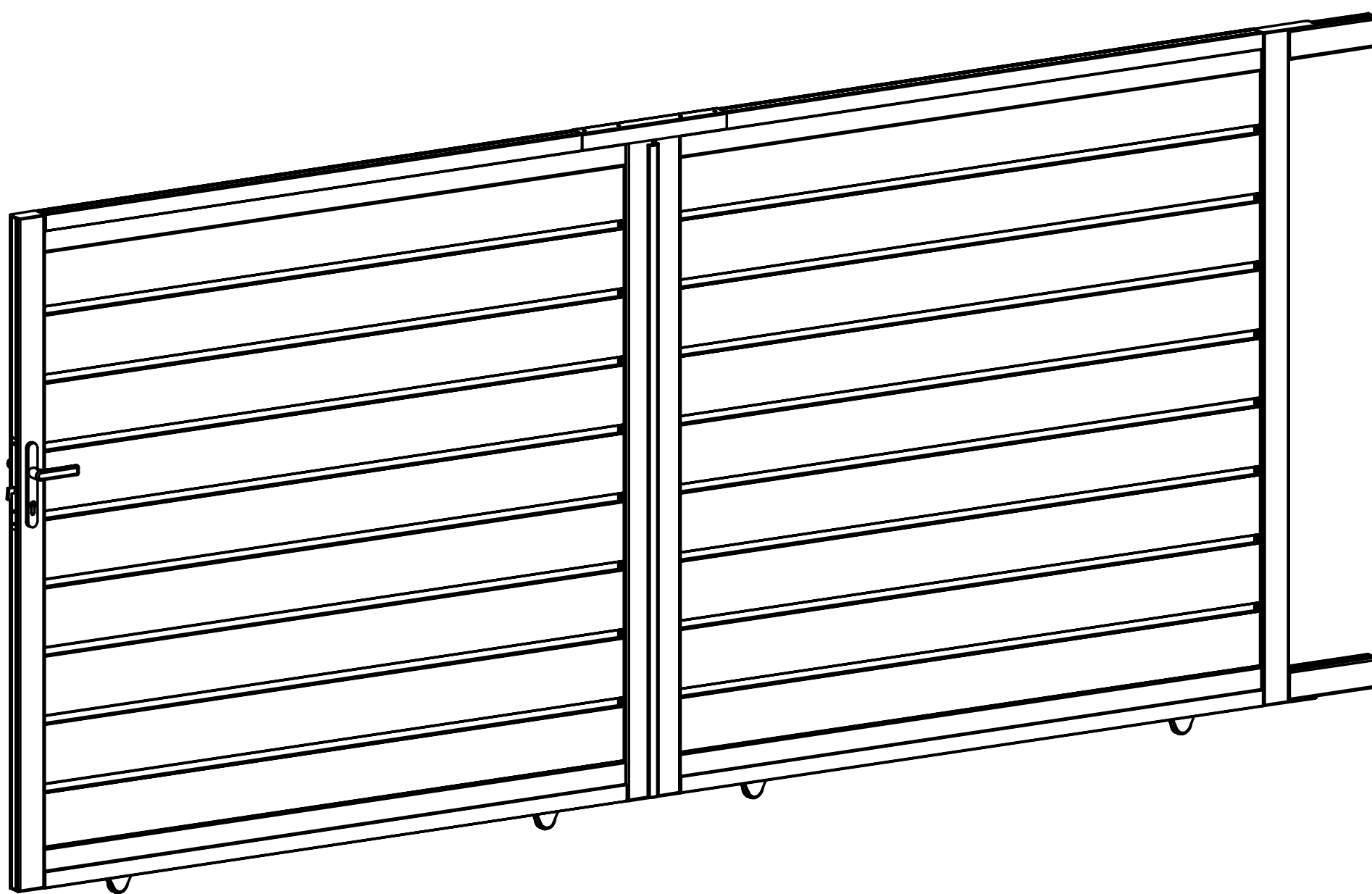
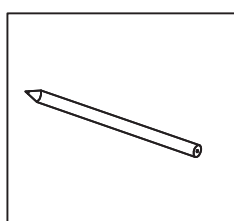
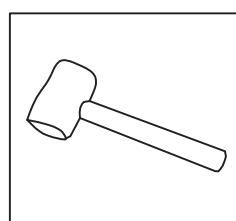
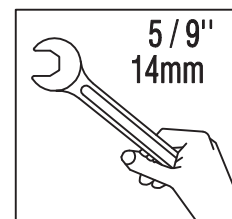
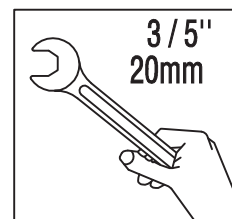
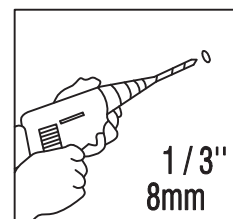
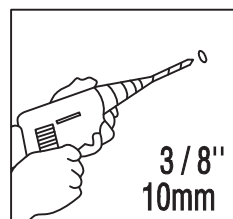
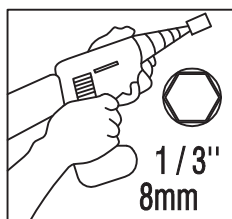
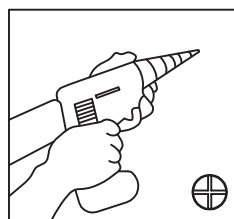
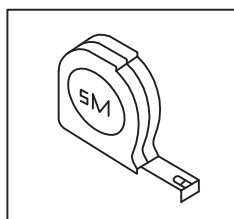

Porte en aluminium
Vent C-F

! AVERTISSEMENT: nécessite un entretien rapide pour s'assurer que la construction est solide.

! WARNING: Need timely maintenance to make sure construction is strong.

! WARNUNG: Sie müssen rechtzeitig gewartet werden, um sicherzustellen, dass die Konstruktion stark ist.

! ADVERTENCIA: Necesita un mantenimiento oportuno para asegurarse de que la construcción sea sólida.

! AVVERTENZA: è necessaria una manutenzione tempestiva per assicurarsi che la costruzione sia robusta.

! WAARSCHUWING: Heeft tijdig onderhoud nodig om ervoor te zorgen dat de constructie sterk is.

Ext.

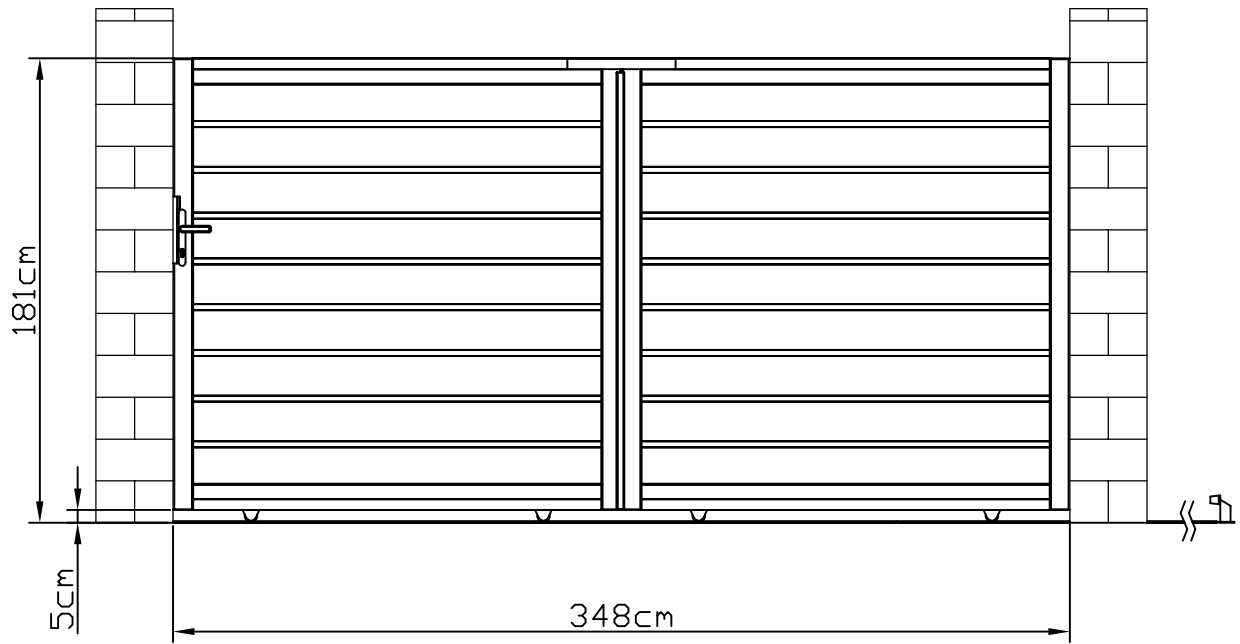

Int.

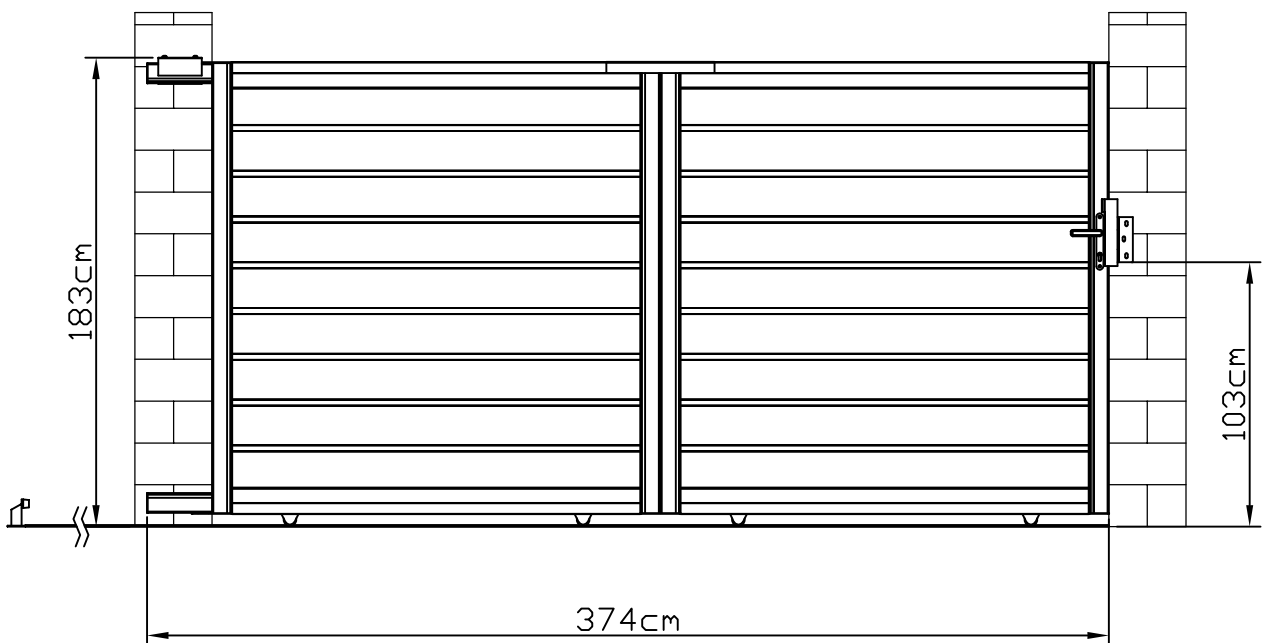

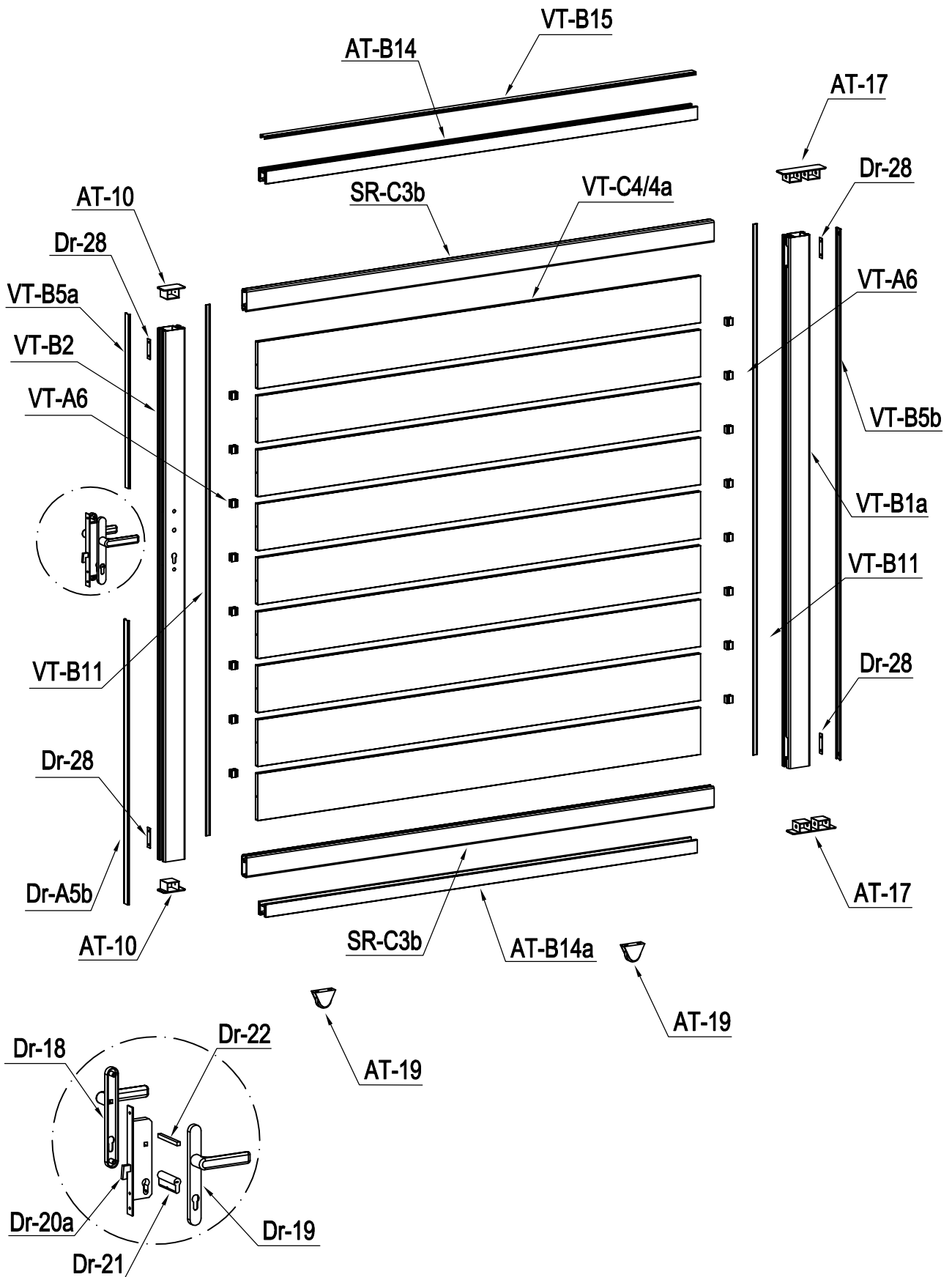

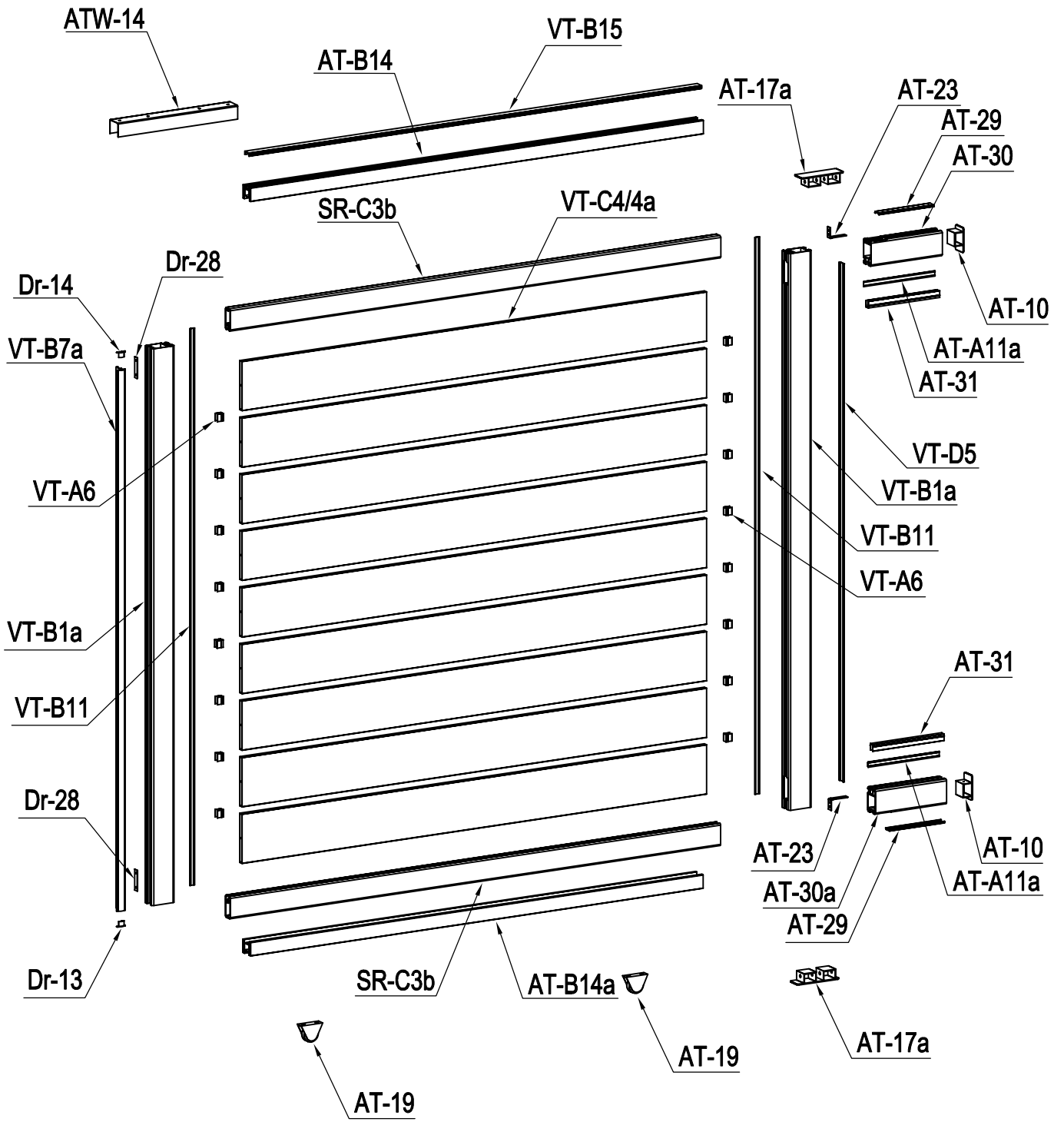

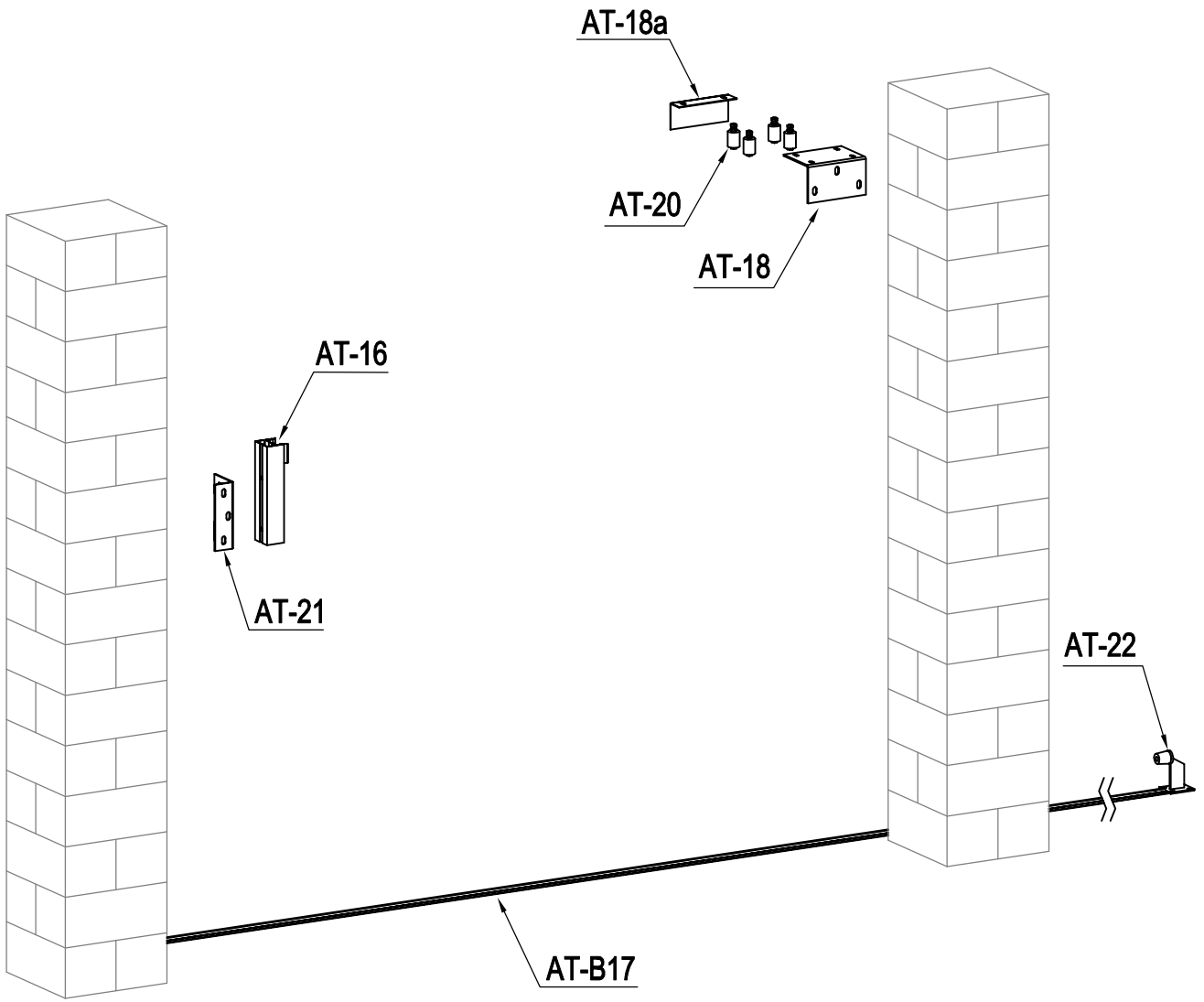





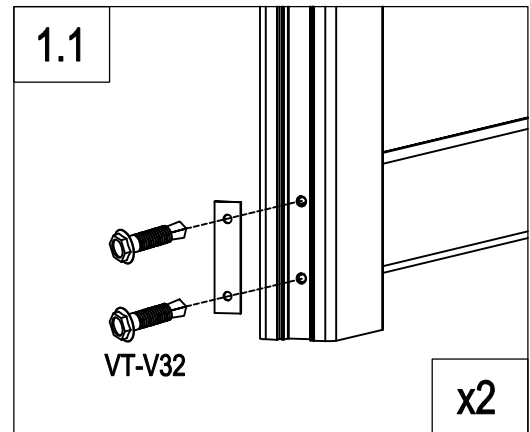
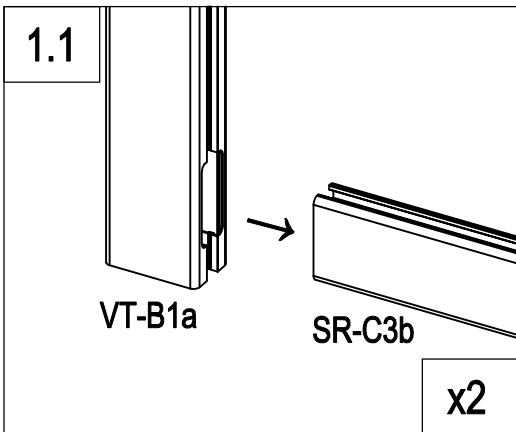
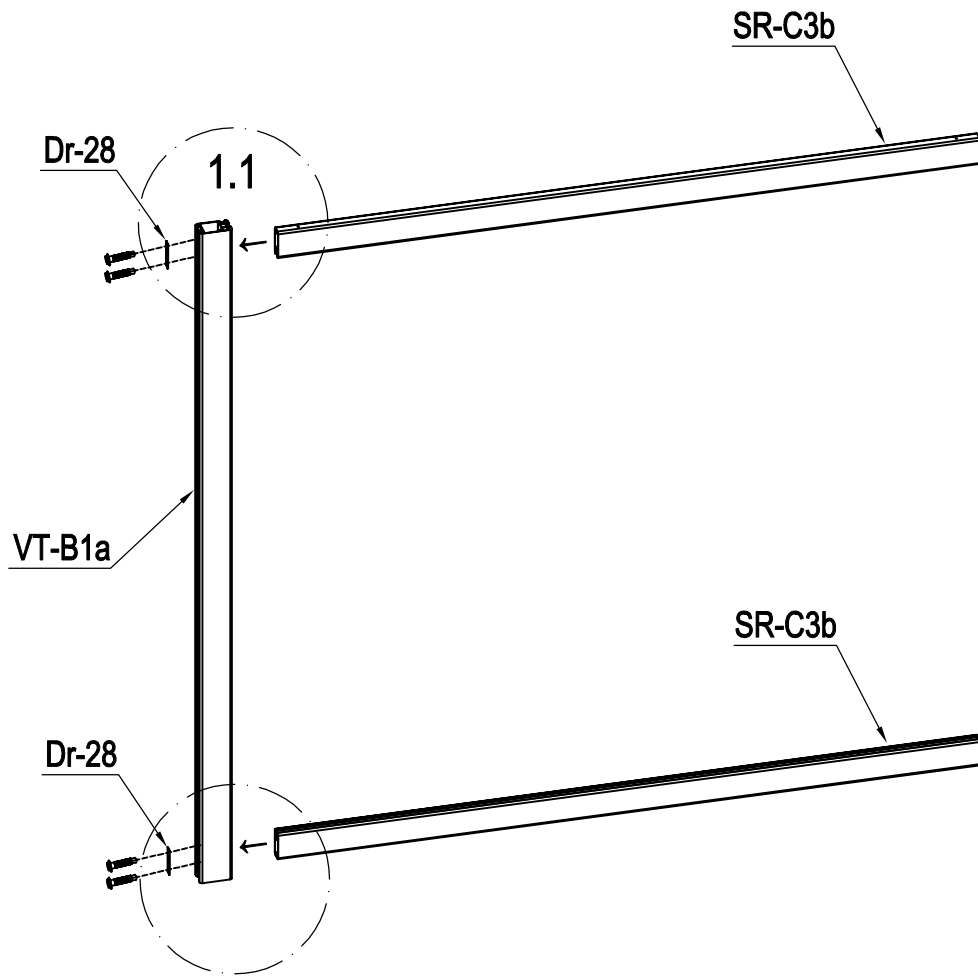

PART LIST

IMAGE	NO.	L.(mm)	QTY	Box NO.	IMAGE	NO.	L.(mm)	QTY	Box NO.
	VT-B1a	1751	3	1/3		AT-18		1	3/3
	VT-B2	1751	1	1/3		AT-18a		1	3/3
	AT-30	250	1	3/3		AT-19		4	3/3
	AT-30a	250	1	3/3		AT-20		4	3/3
	SR-C3b	1721	4	1/3		AT-21		1	3/3
	VT-C4	1630	2	1/3		AT-22		1	3/3
	VT-C4	1630	14	2/3		AT-23		2	3/3
	VT-C4a	1630	2	1/3		Dr-18		1	3/3
	VT-D5	1626	1	1/3		Dr-19		1	3/3
	VT-B5a	573.5	1	1/3		Dr-20a		1	3/3
	Dr-A5b	937	1	1/3		Dr-21		1	3/3
	VT-B5b	1751	1	1/3		Dr-22		1	3/3
	AT-29	193	2	3/3		Dr-25		1	3/3
	VT-B11	1751	4	1/3		Dr-25a		2	3/3
	AT-A11a	250	2	3/3		Dr-27		2	3/3
	VT-A6	23	32	3/3		VT-V30		4	3/3
	AT-31	250	2	3/3		VT-V31		10	3/3
	VT-B7a	1698	1	1/3		VT-V32		32	3/3
	AT-B14	1588	2	3/3		VT-V33		4	3/3
	AT-B14a	1588	2	3/3		VT-V34		76	3/3
	VT-B15	1587	2	3/3		VT-V35		6	3/3
	AT-16	260	1	3/3		VT-V36		2	3/3
	AT-B17	1412	5	3/3		VT-V37		8	3/3
	AT-17		2	3/3		VT-V38		50	3/3
	AT-17a		2	3/3		Dr-28		6	3/3
	AT-10		4	3/3		AT-22J		7	3/3
	Dr-13		1	3/3		ATW-14		1	3/3
	Dr-14		1	3/3					

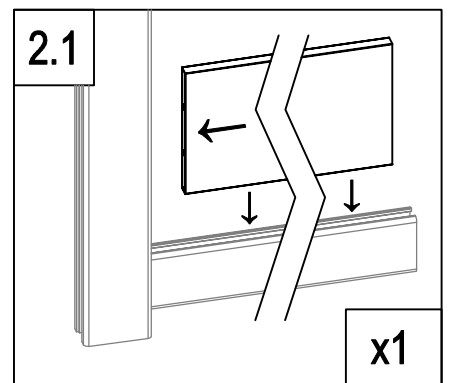
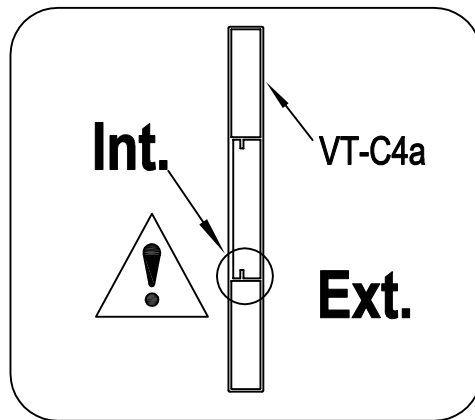
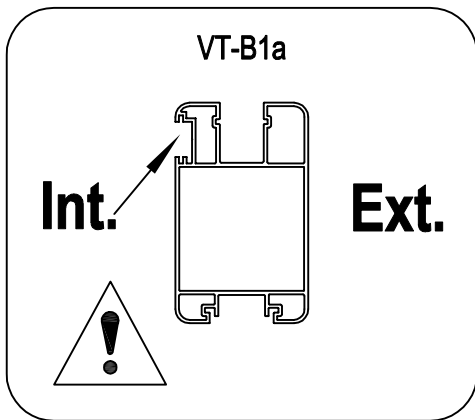
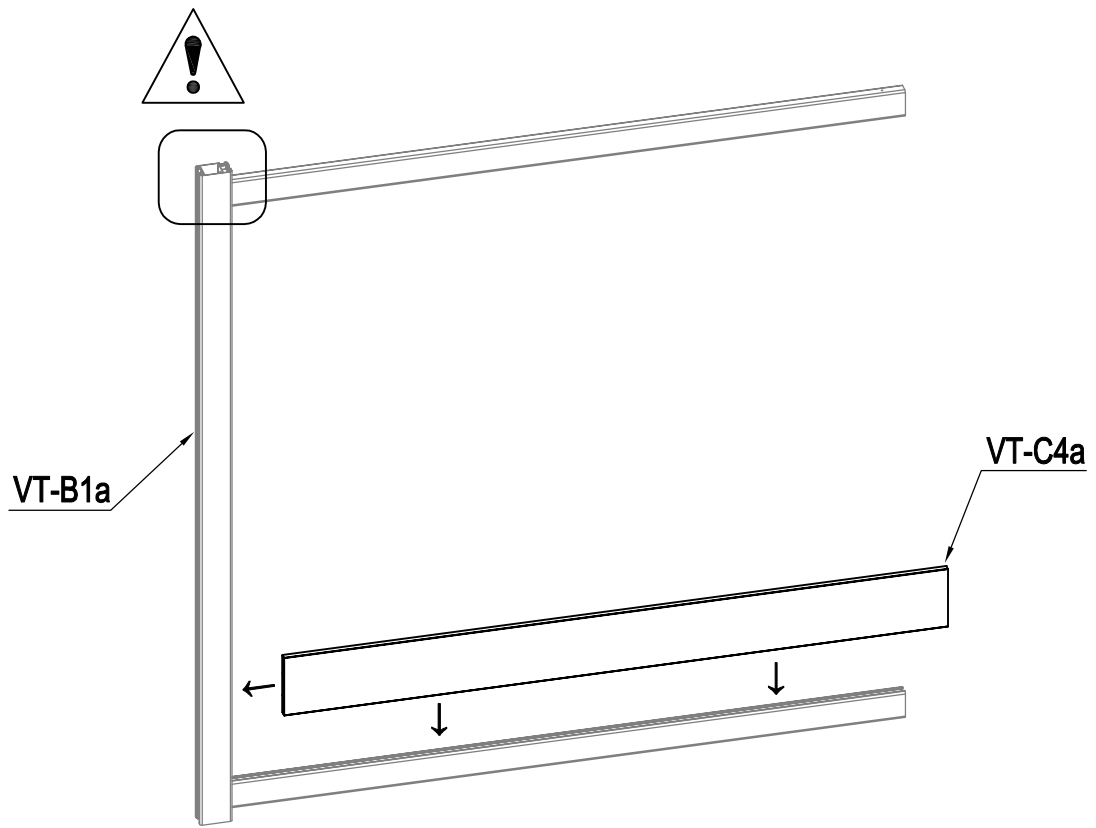

	VT-B1a	1
	SR-C3b	2
	Dr-28	2
	VT-V32	4



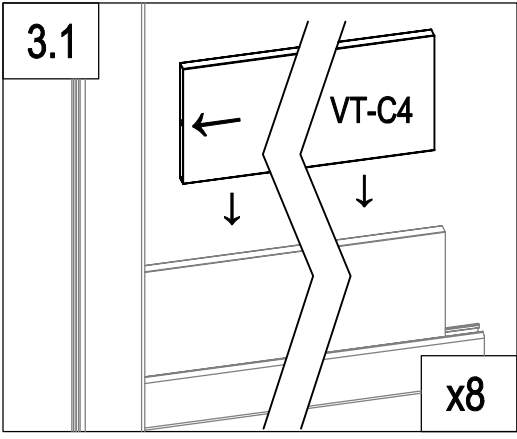
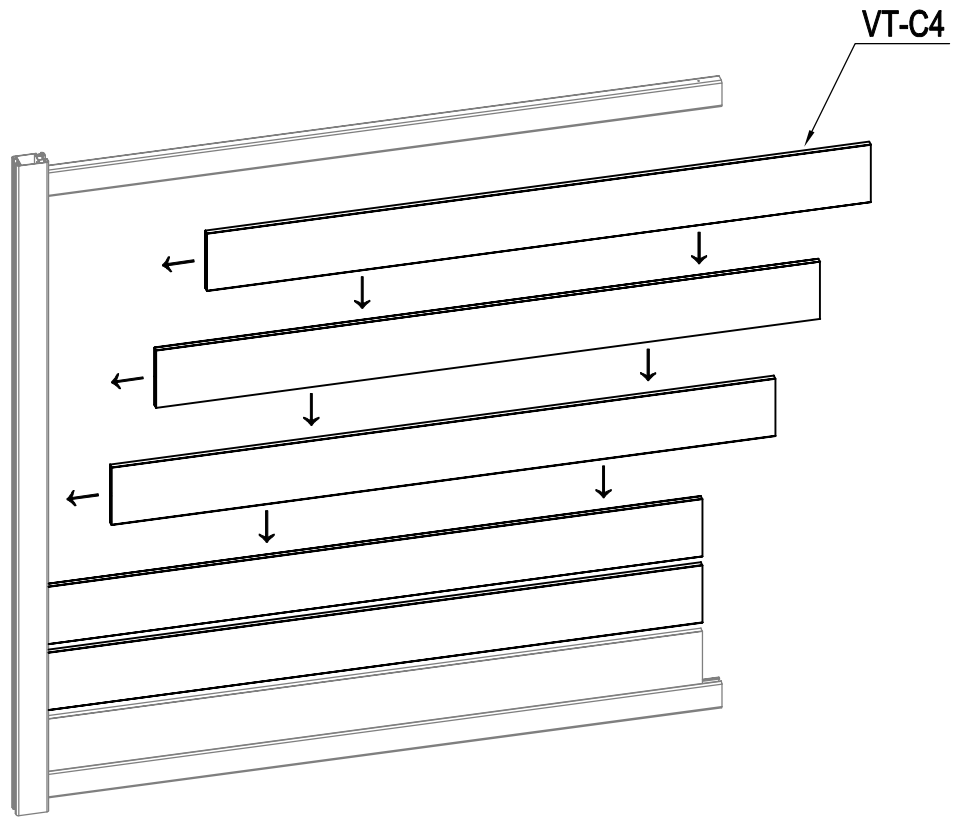

	VT-C4a	1
---	--------	---

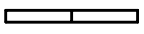

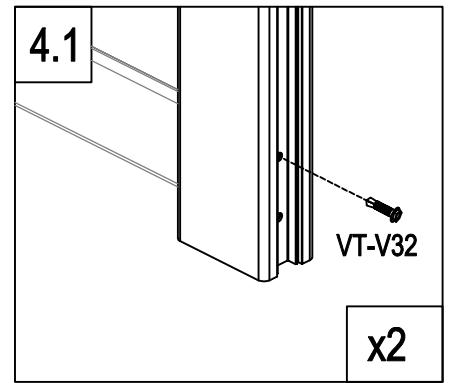
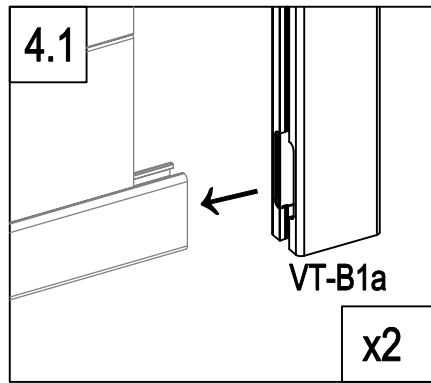
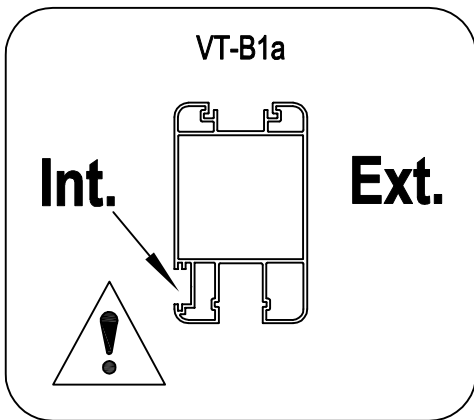
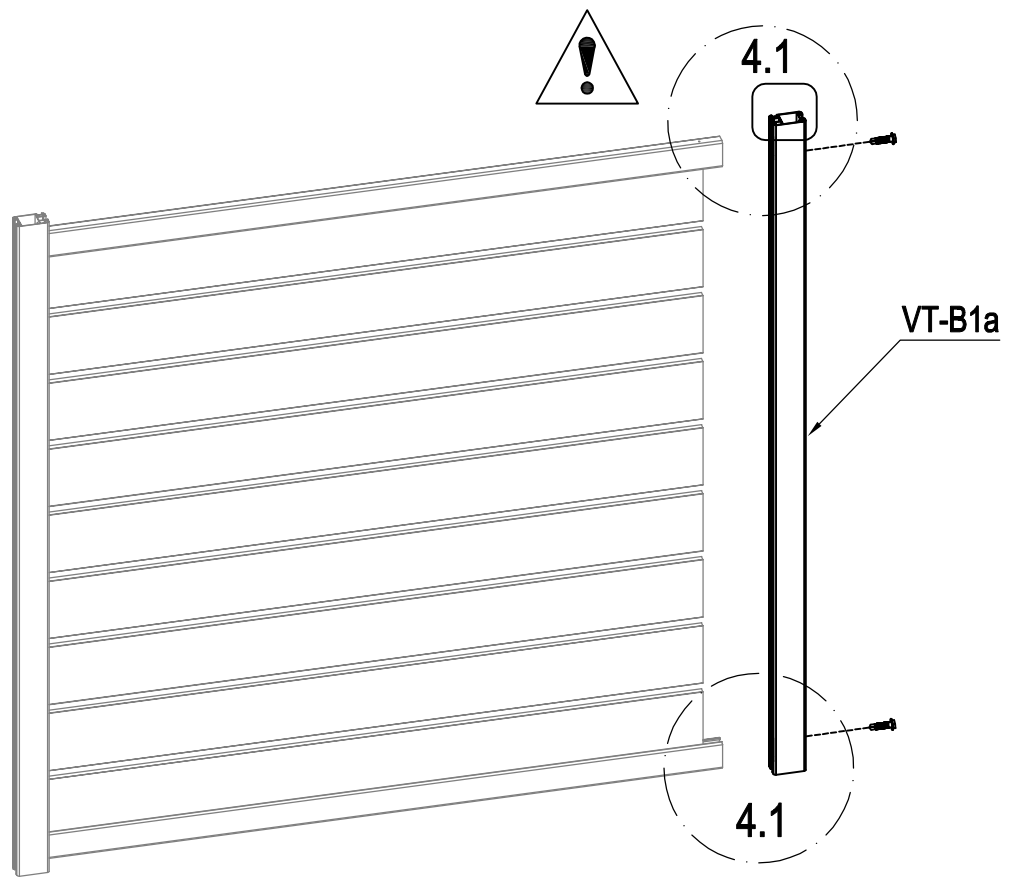
	VT-C4	8
---	-------	---



	VT-B1a	1
	VT-V32	2

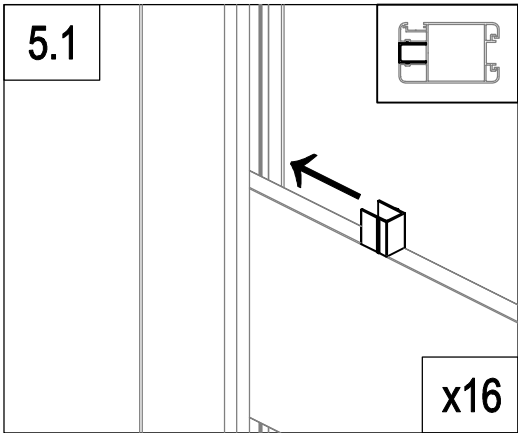
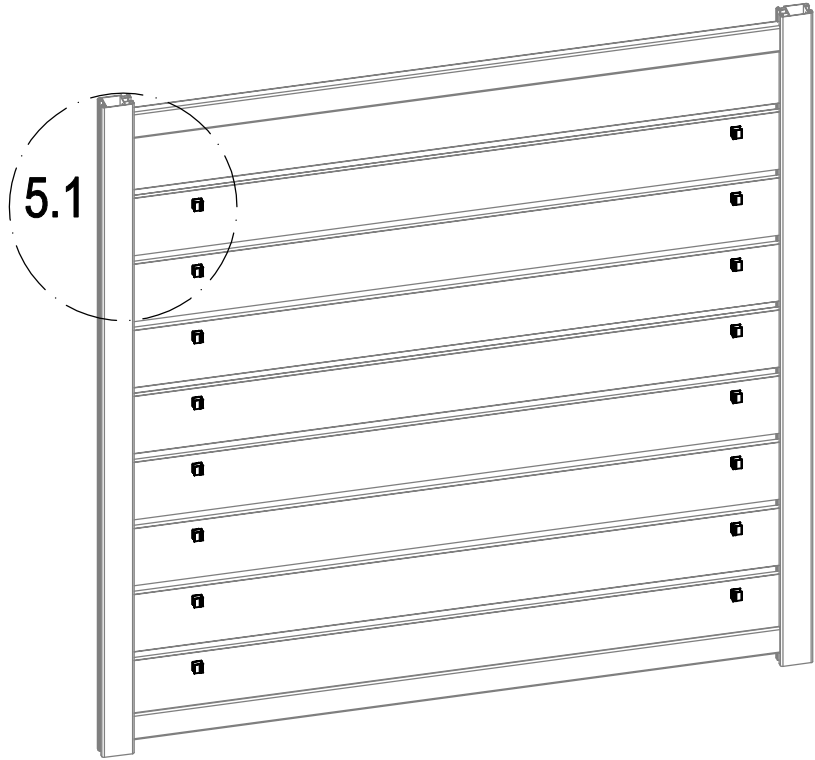

	VT-A6	16
--	-------	----

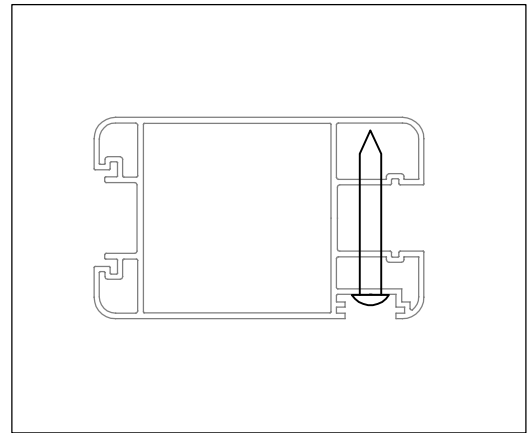
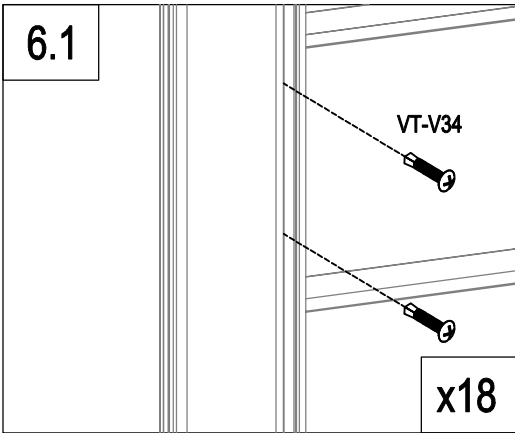
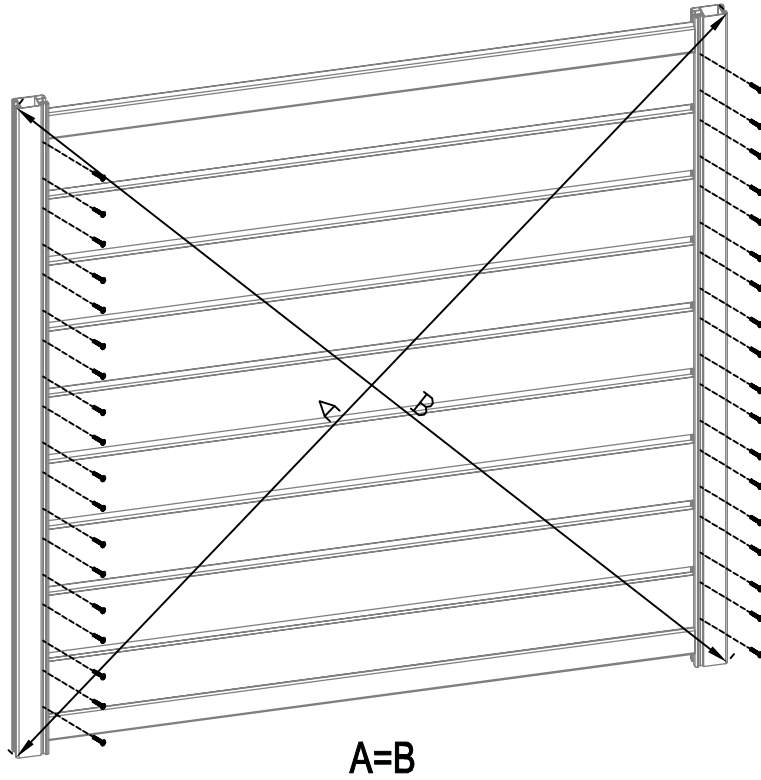

	VT-V34	36
---	--------	----

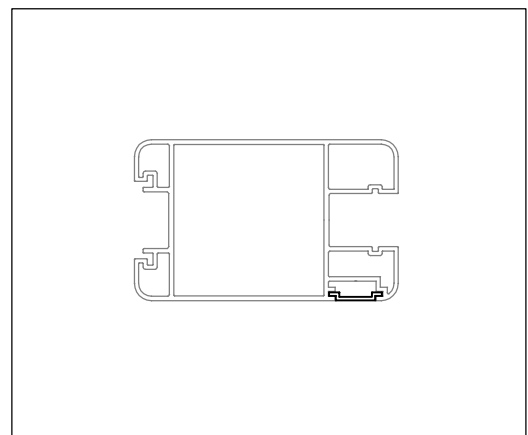
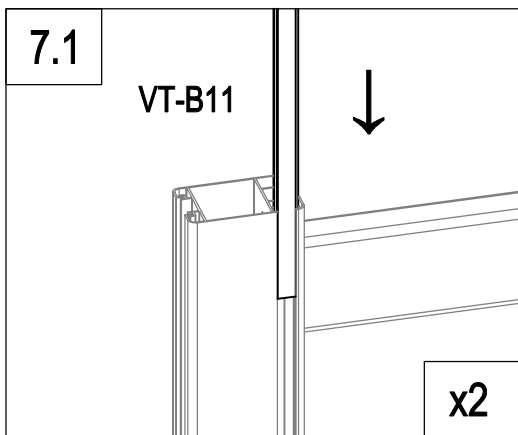
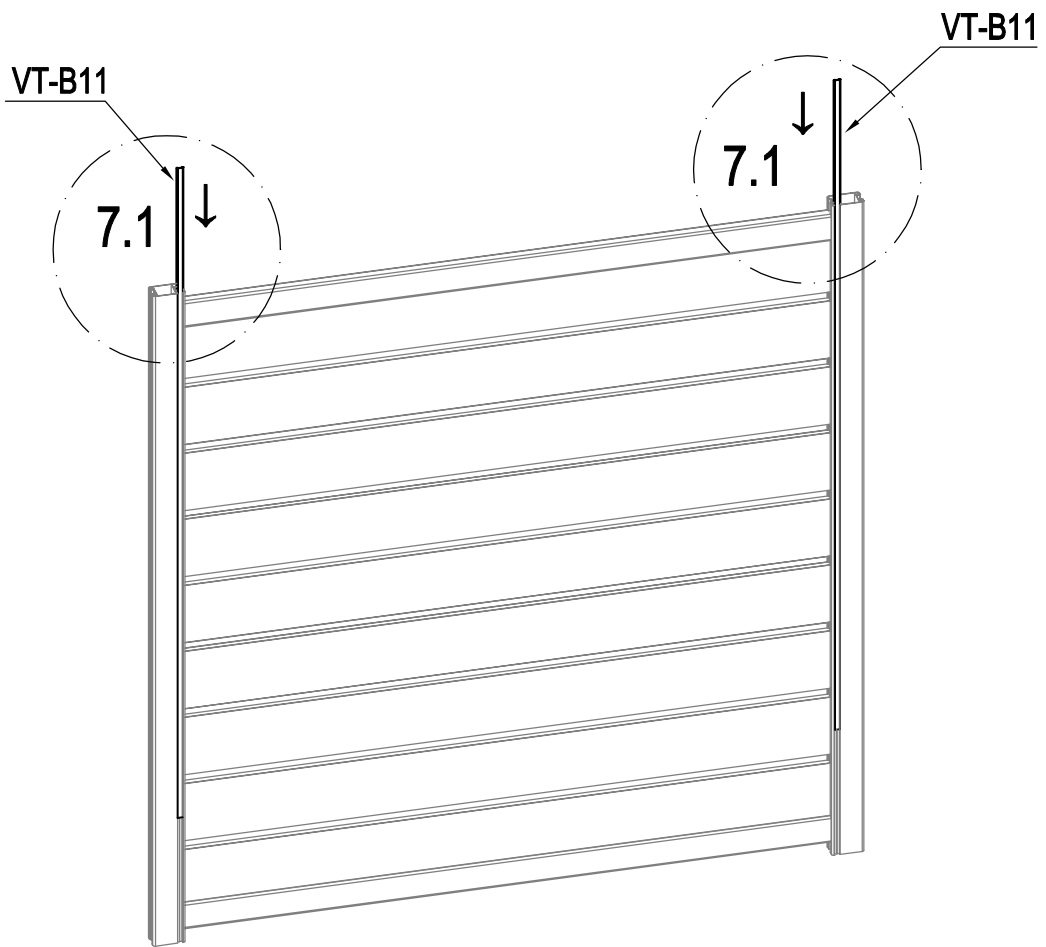

	VT-B11	2
---	--------	---

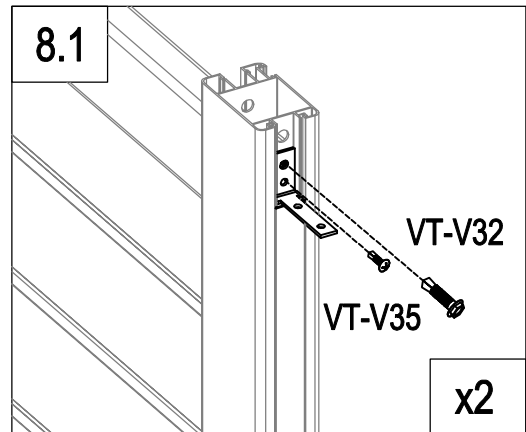
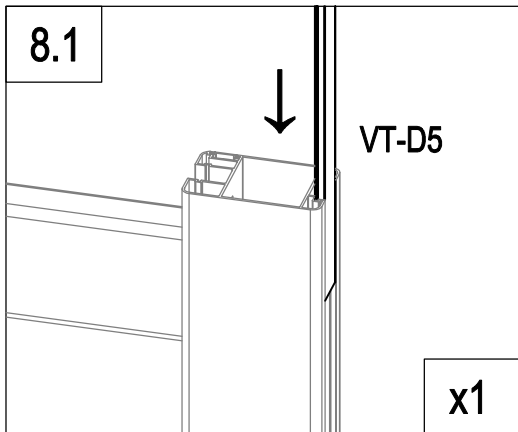
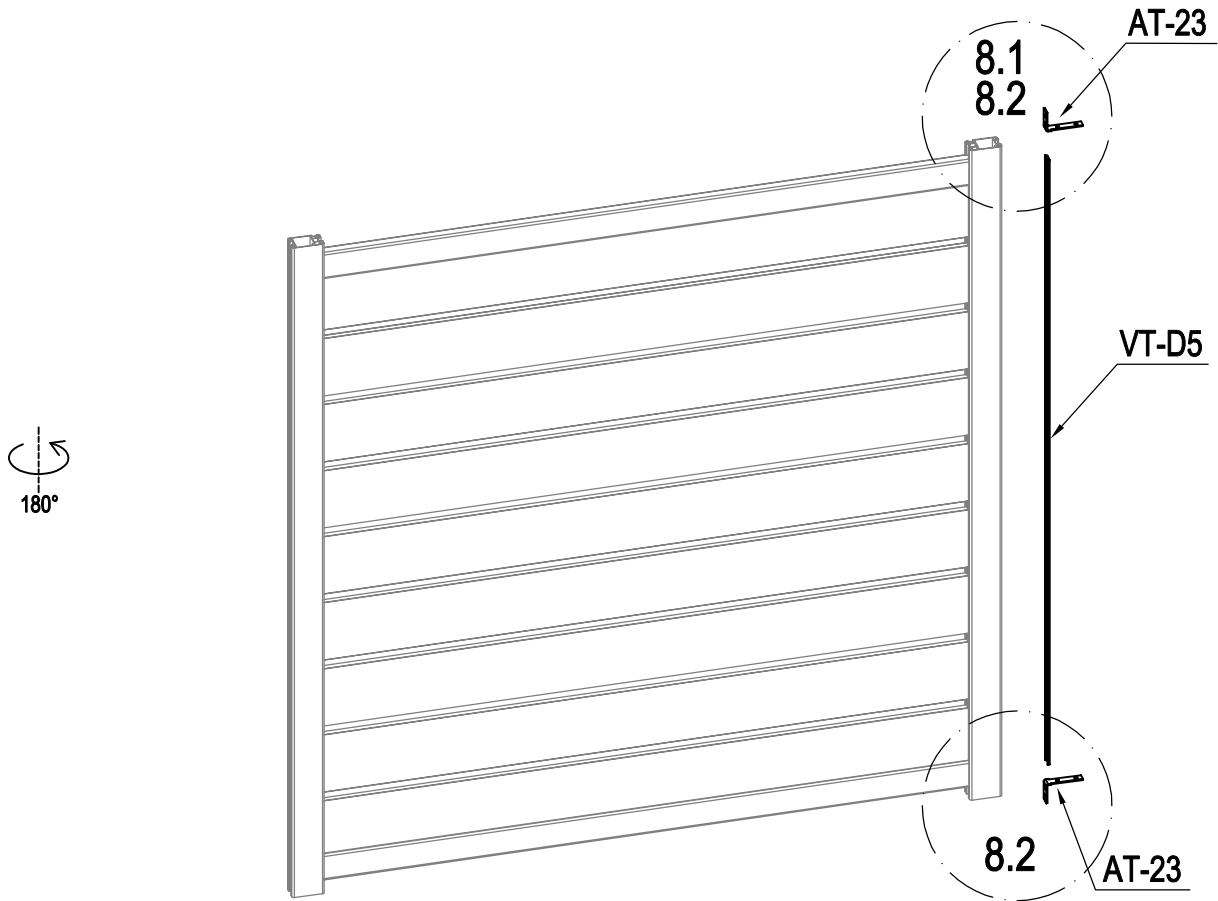

	VT-D5	1
	AT-23	2
	VT-V32	2
	VT-V35	2

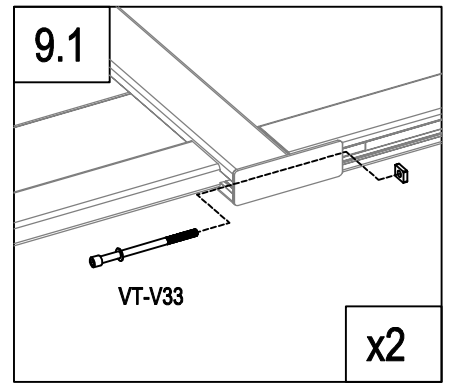
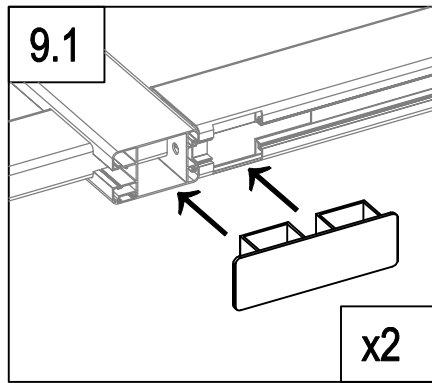
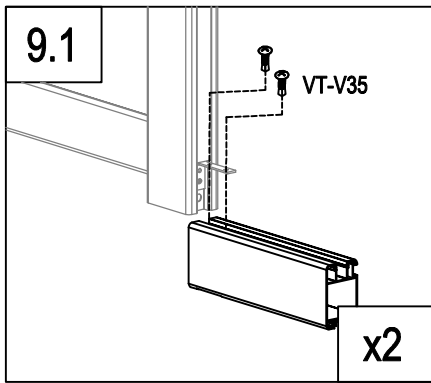
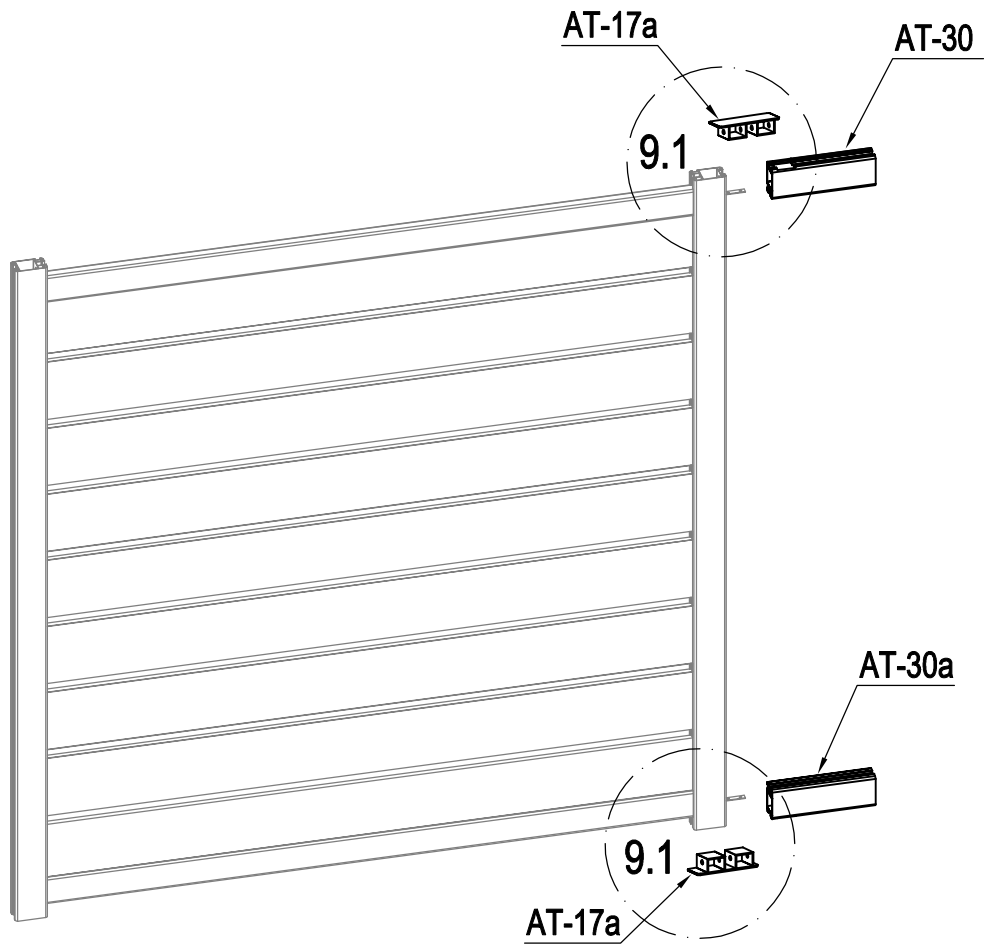

	AT-30	1
	AT-30a	1
	AT-17a	2

	VT-V33	2
	VT-V35	4

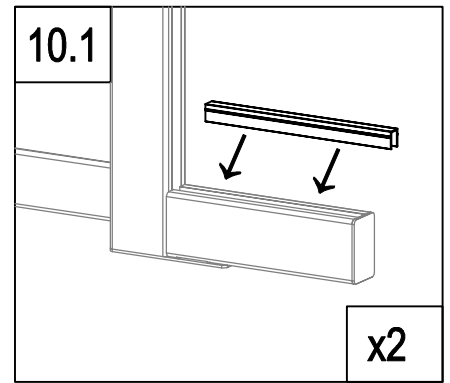
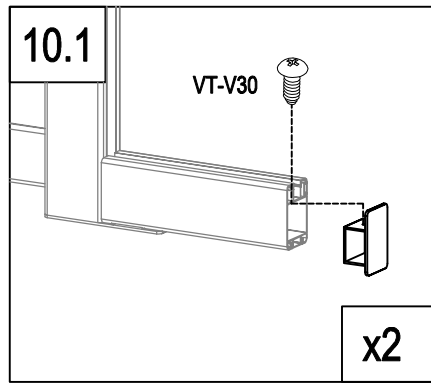
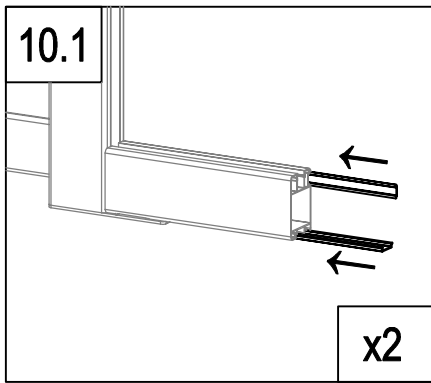
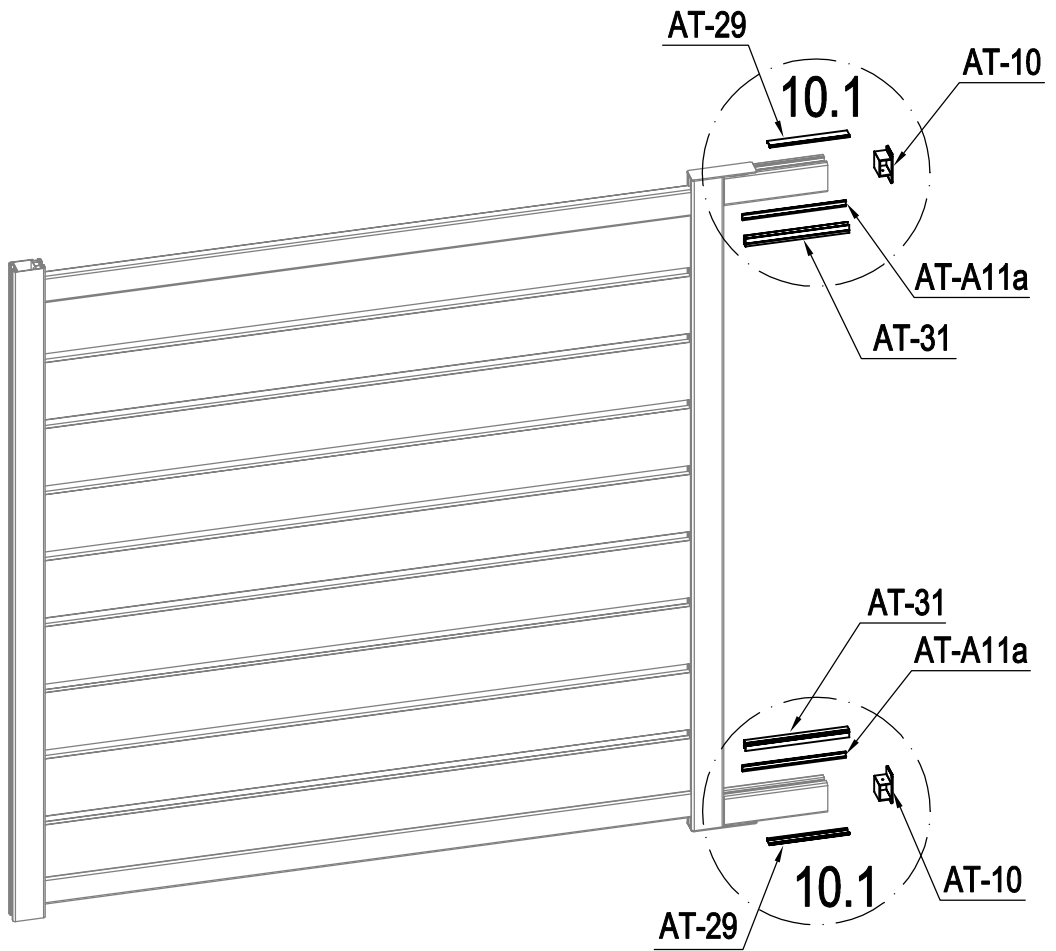



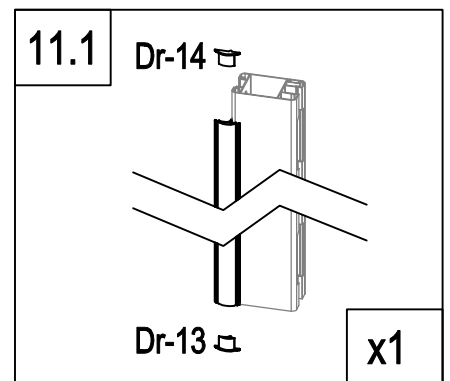
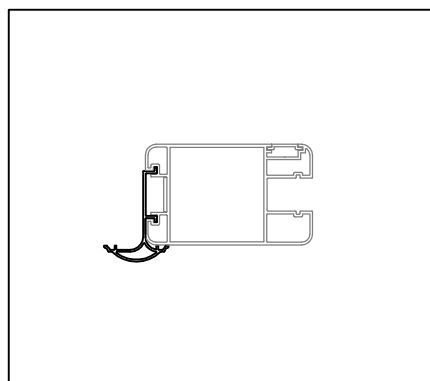
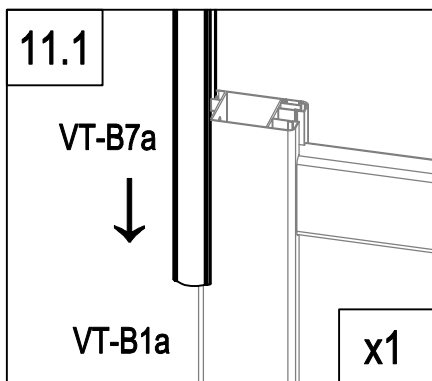
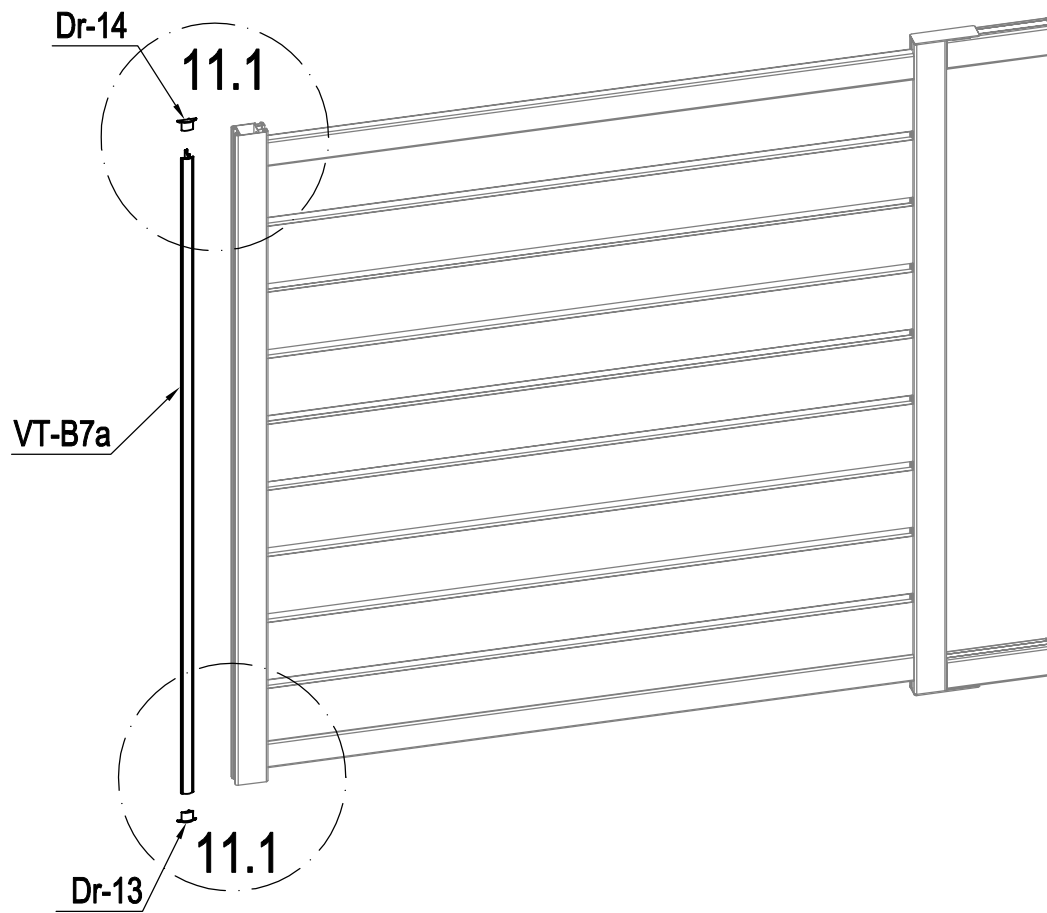

	AT-29	2
	AT-A11a	2
	AT-31	2

	AT-10	2
	VT-V30	2

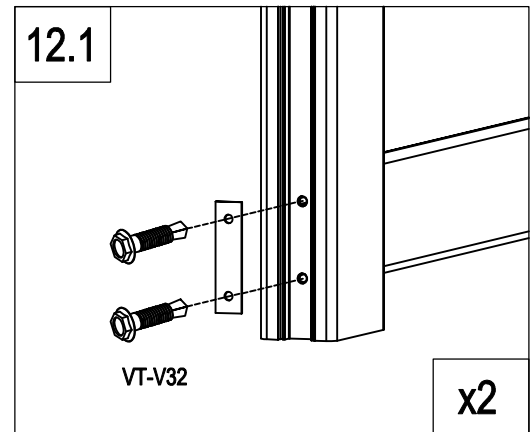
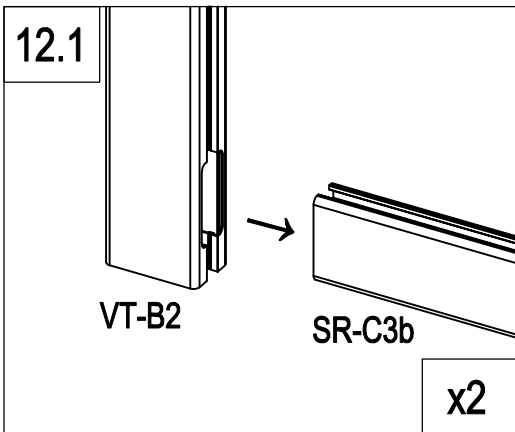
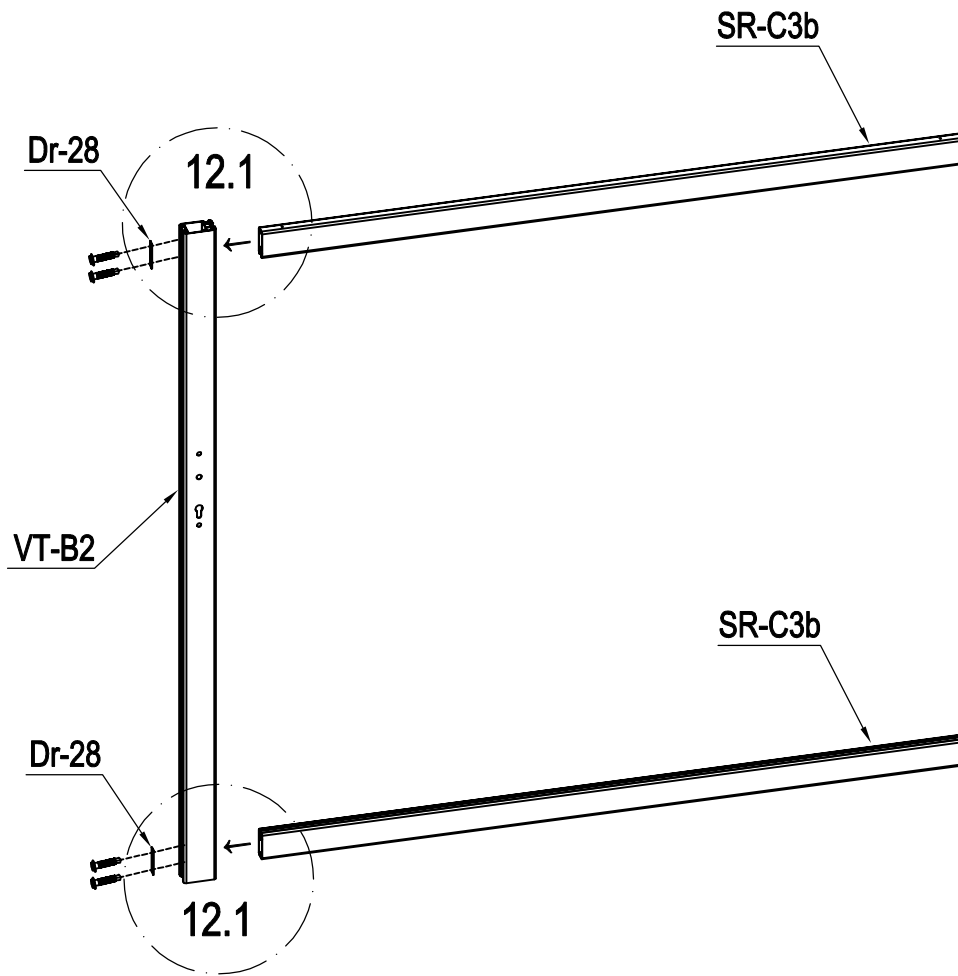

	VT-B7a	1
	Dr-13	1
	Dr-14	1



	VT-B2	1
	SR-C3b	2
	Dr-28	2
	VT-V32	4

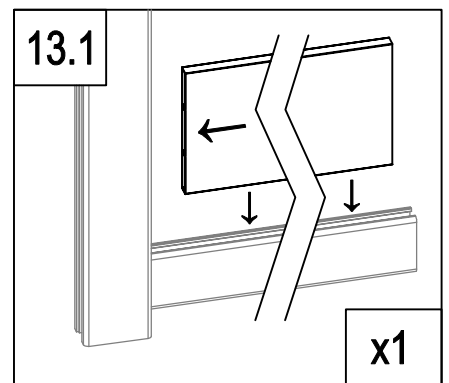
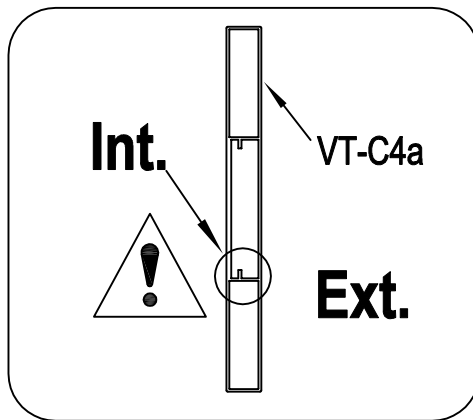
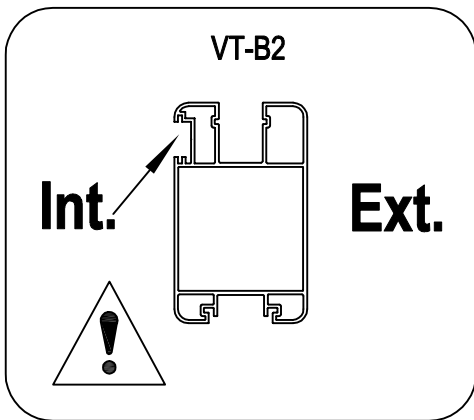
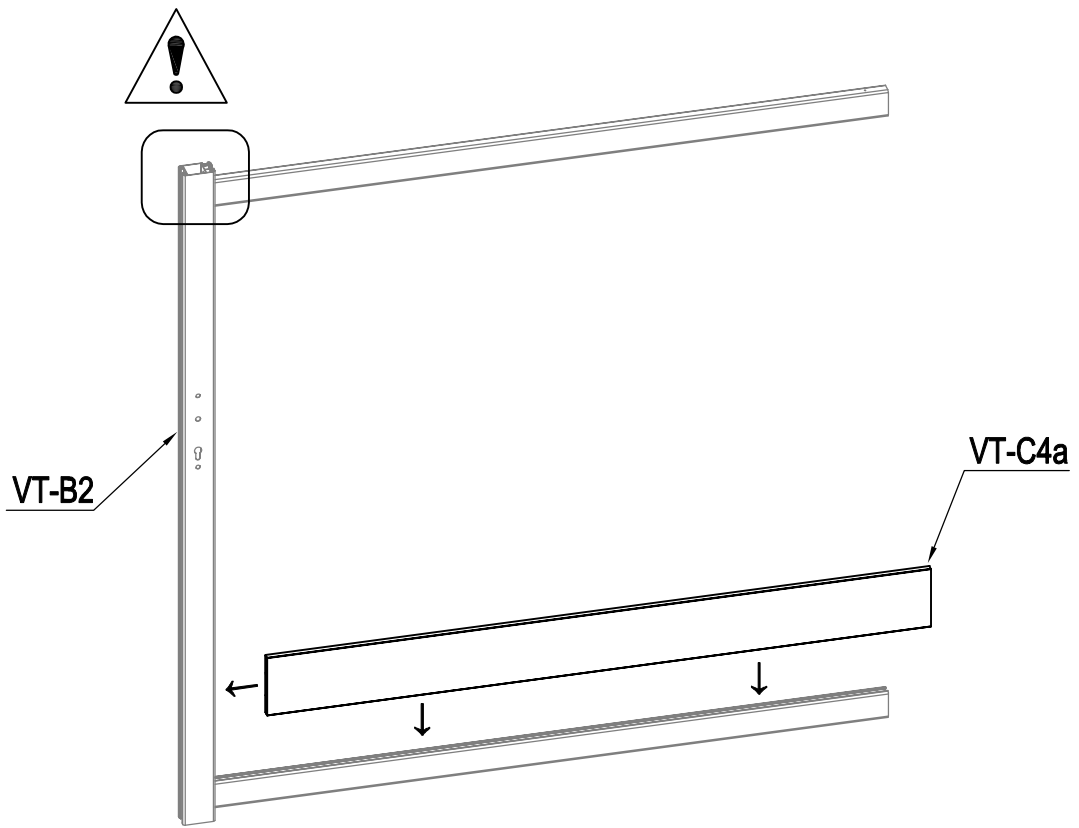

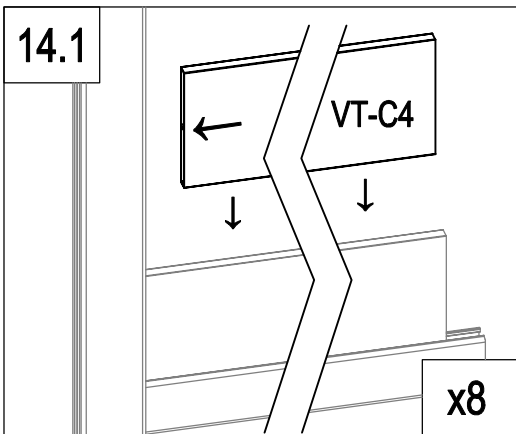
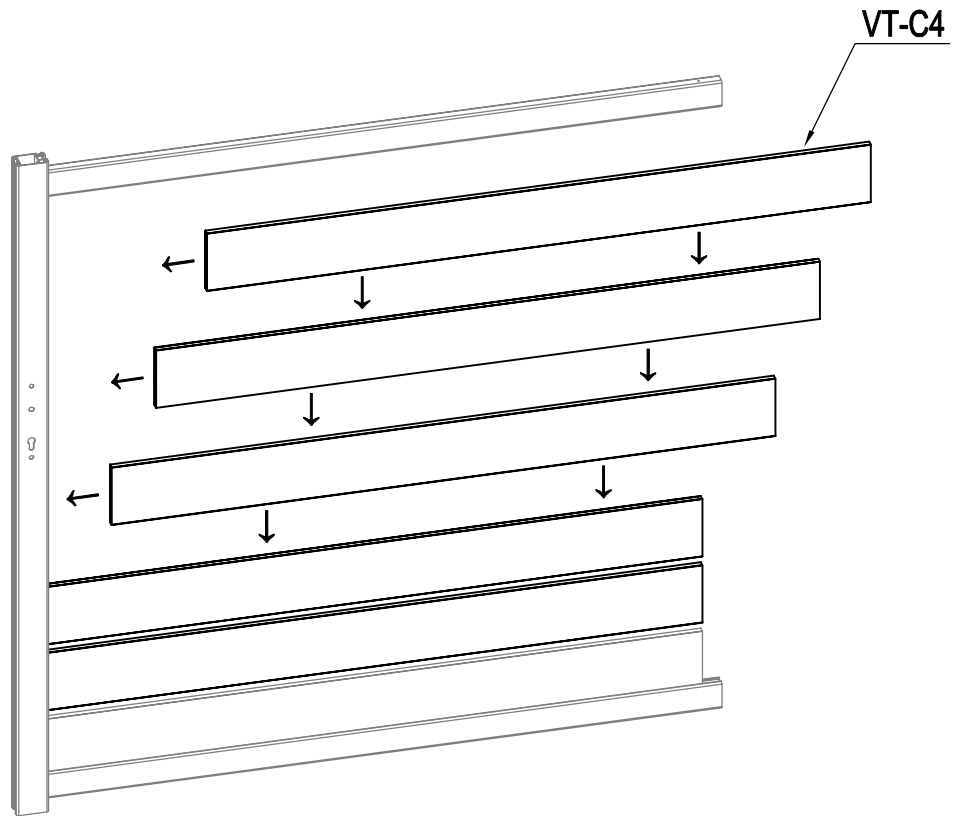

	VT-C4a	1
---	--------	---

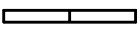

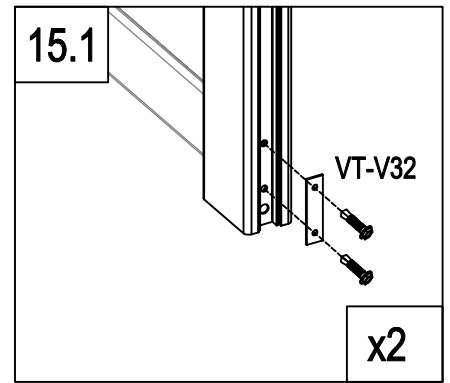
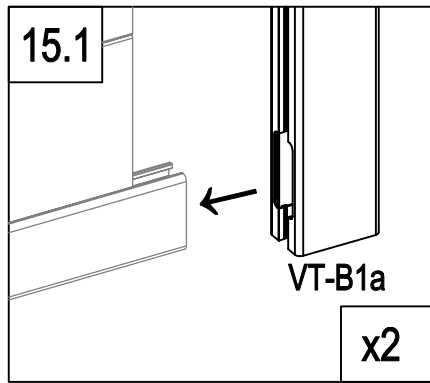
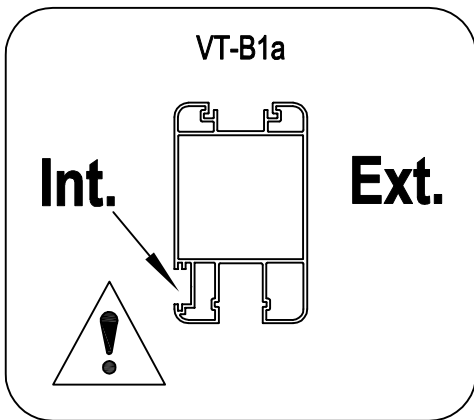
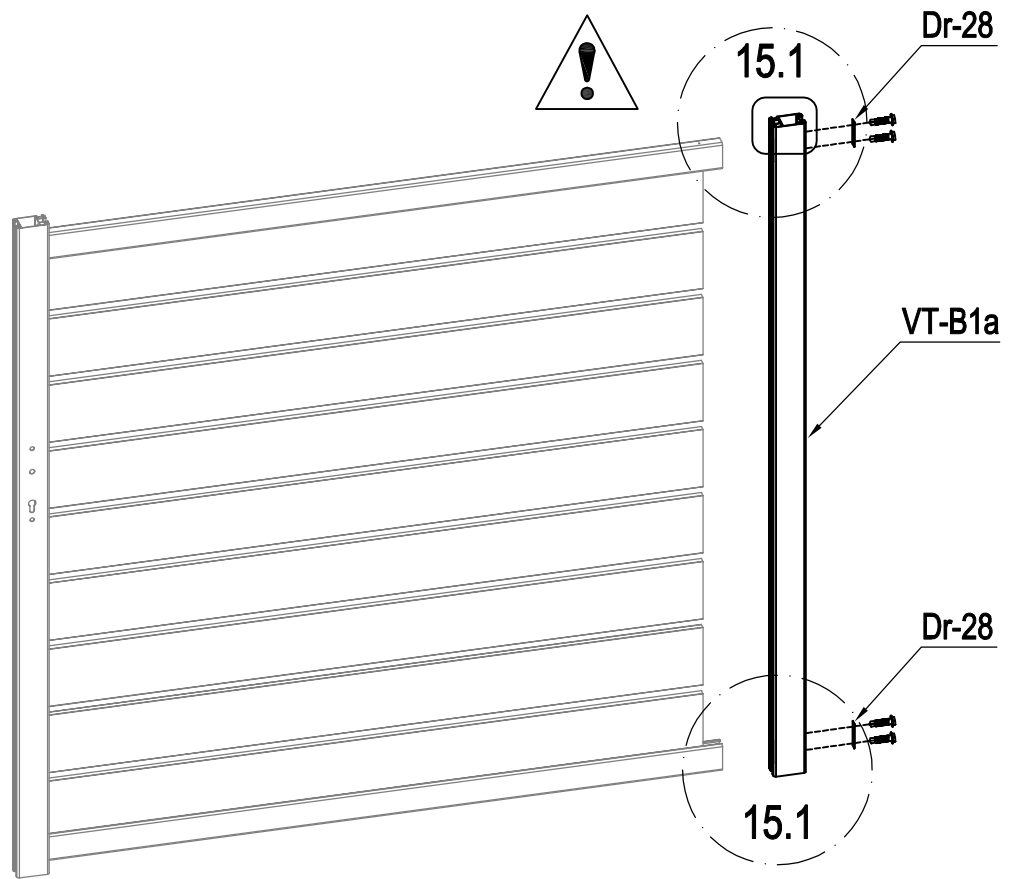
	VT-C4	8
---	-------	---



	VT-B1a	1
	Dr-28	2
	VT-V32	4

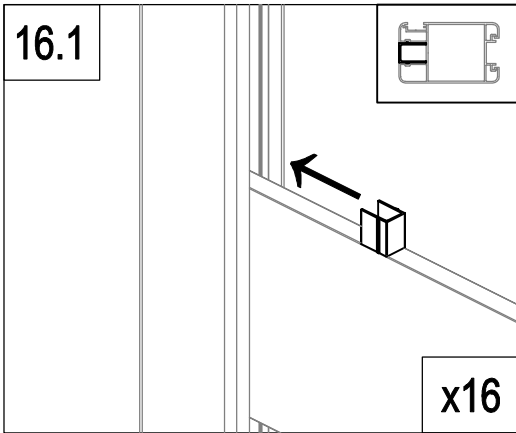
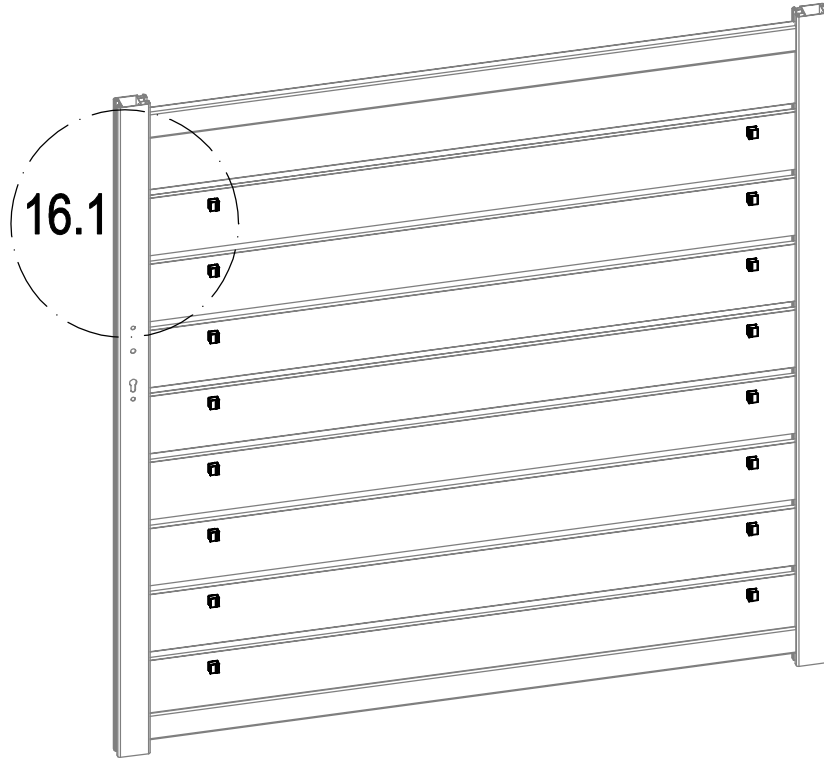

	VT-A6	16
--	-------	----

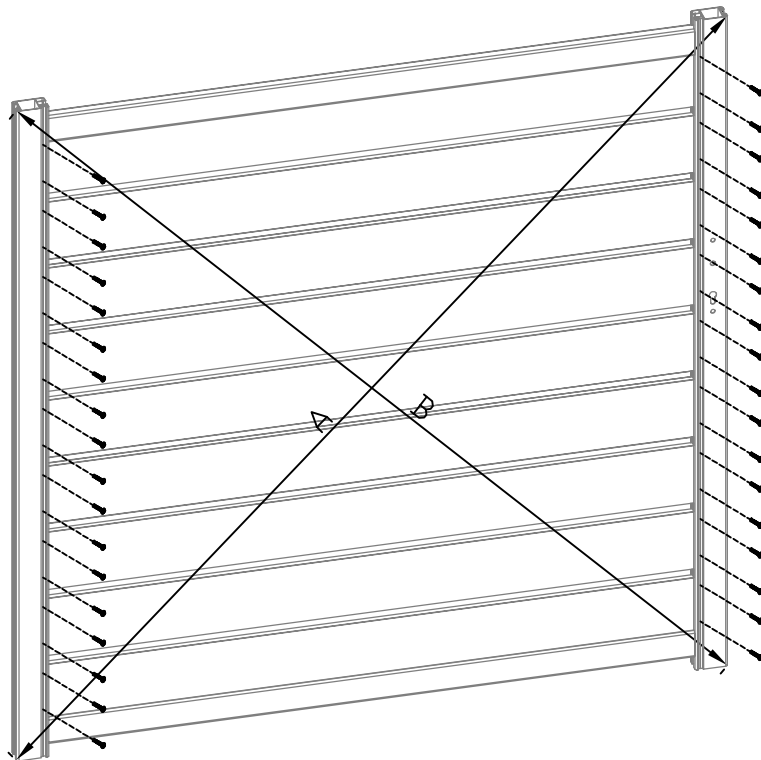
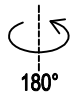

A=B

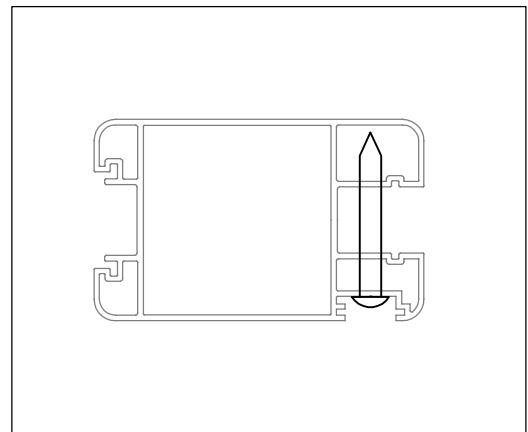
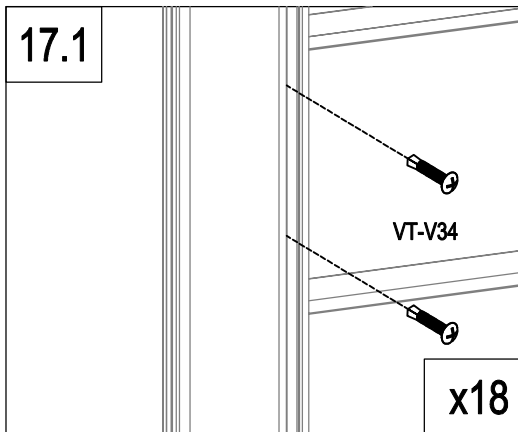

	VT-V34	36
---	--------	----

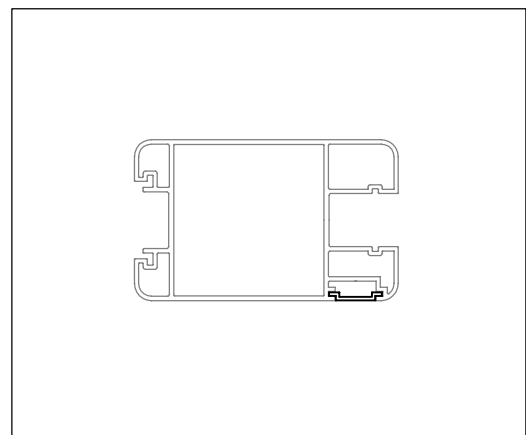
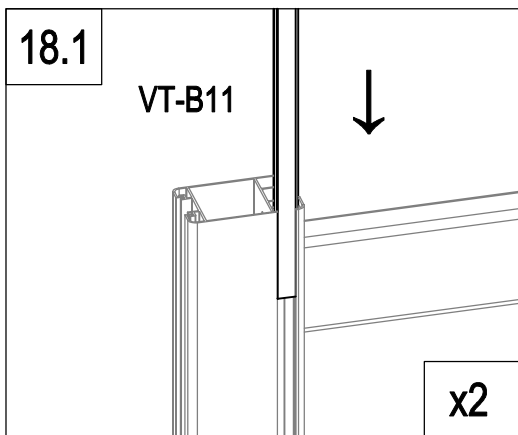
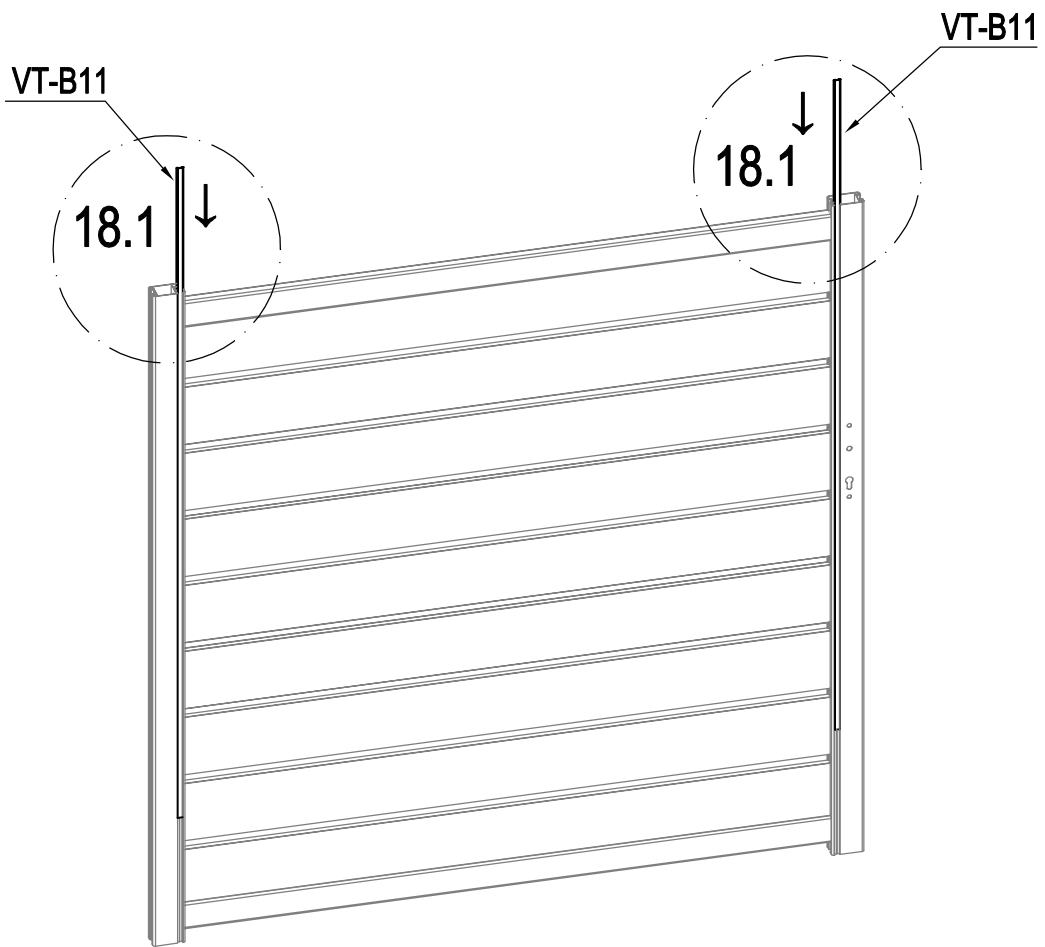

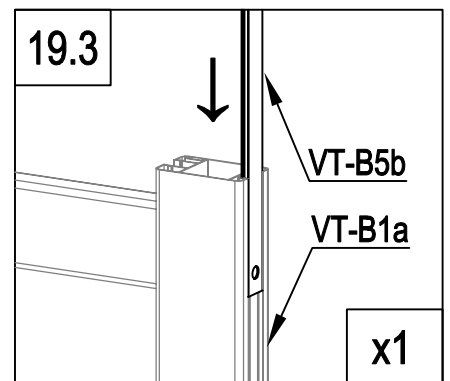
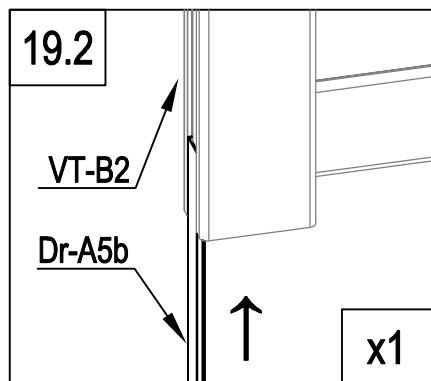
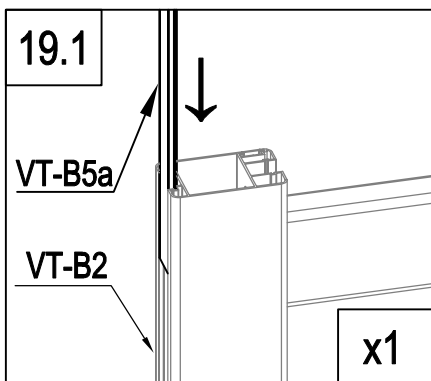
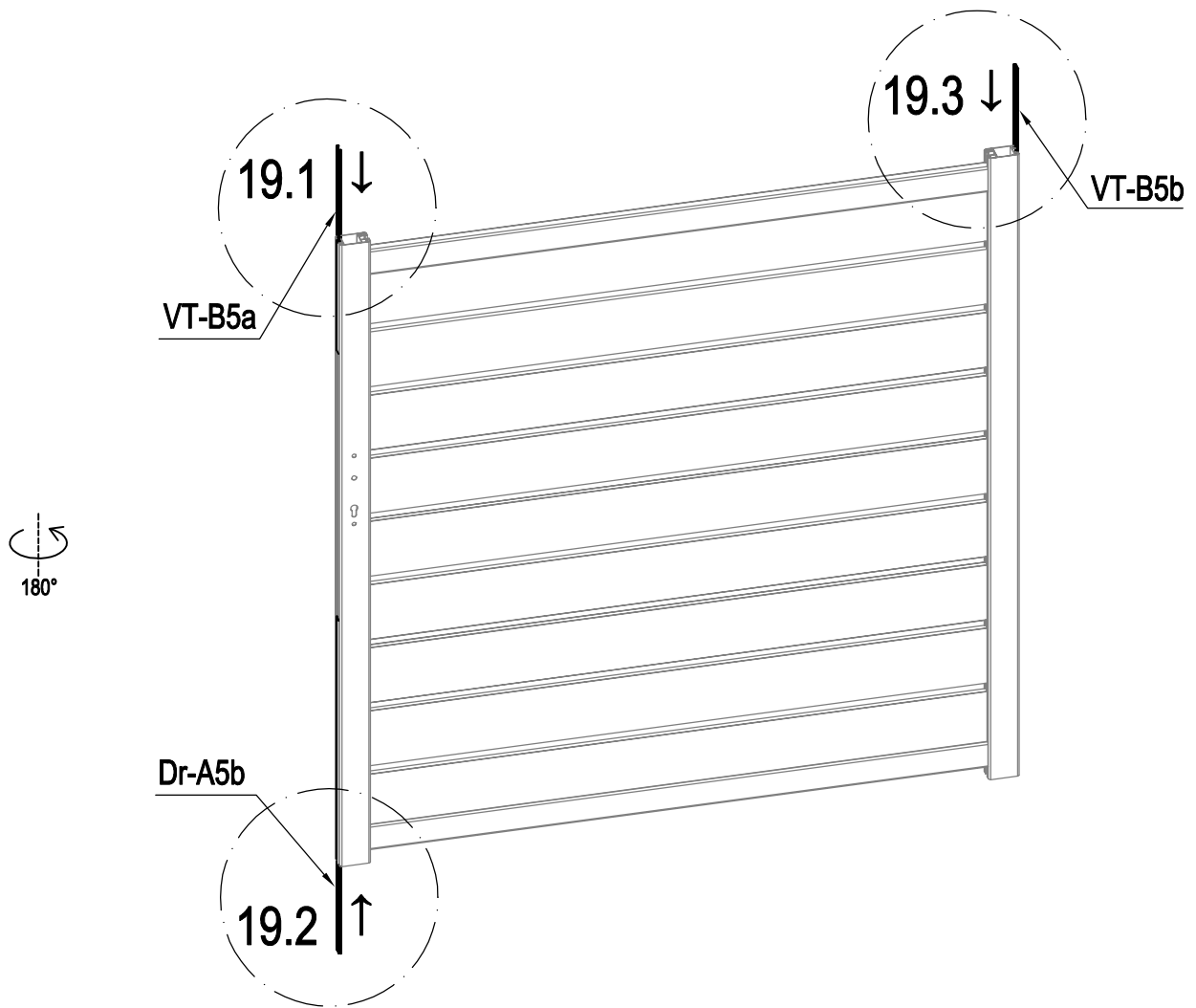

	VT-B11	2
---	--------	---



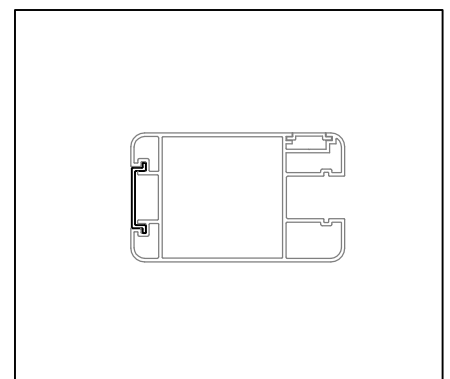

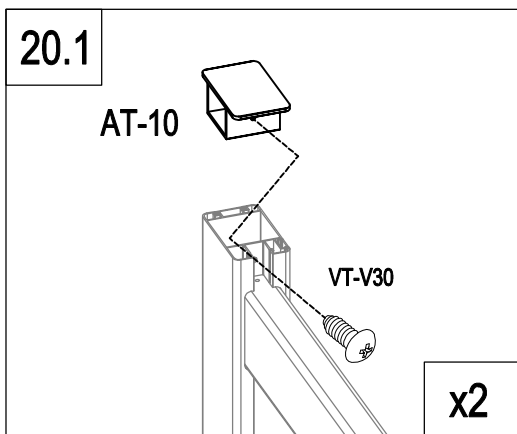
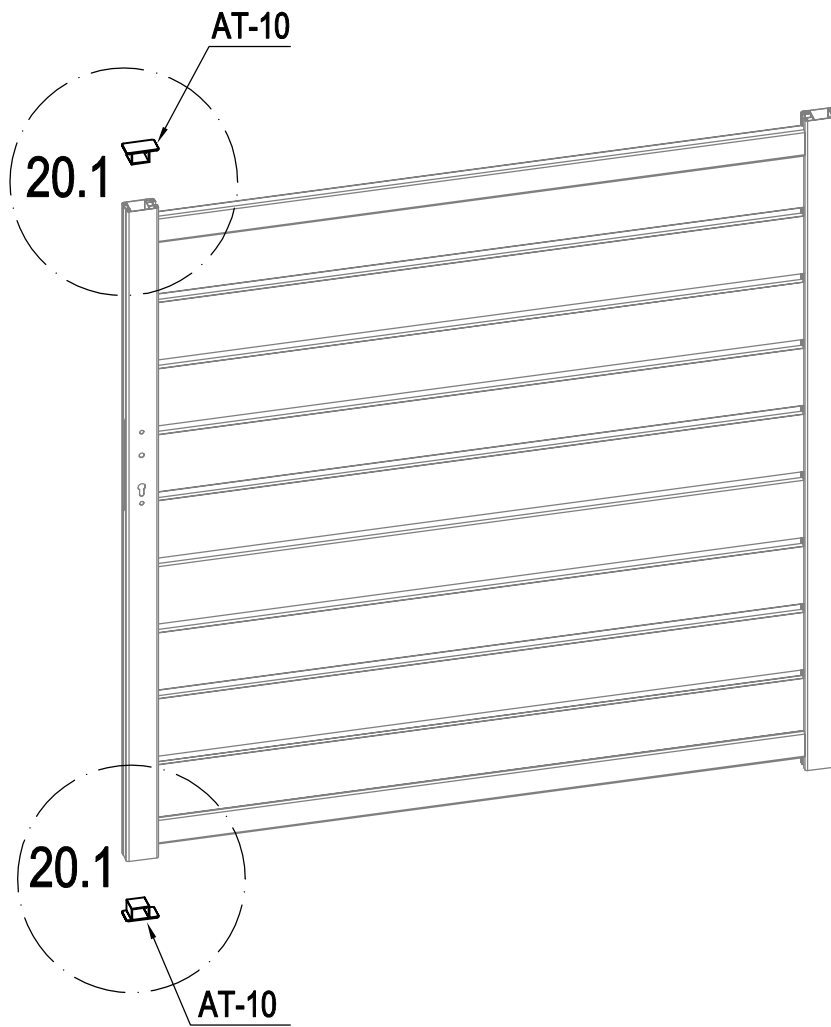
	VT-B5b	1
	VT-B5a	1
	Dr-A5b	1



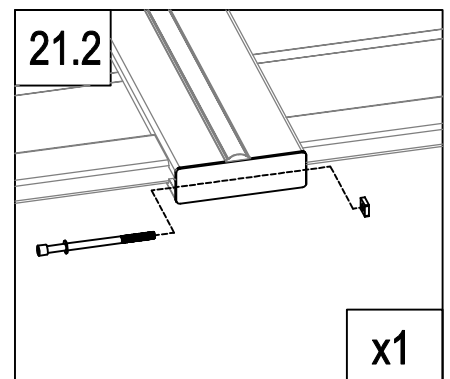
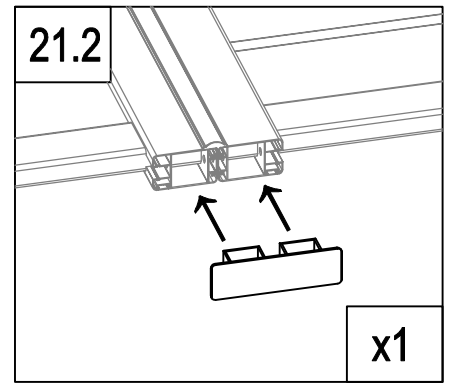
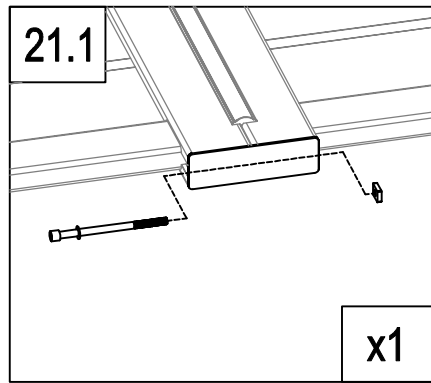
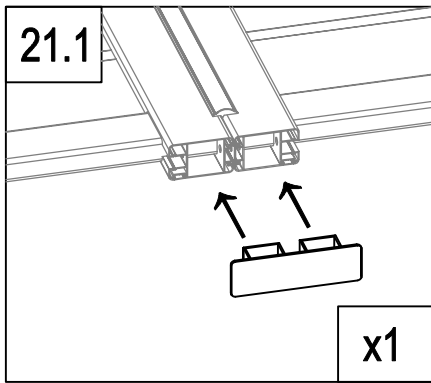
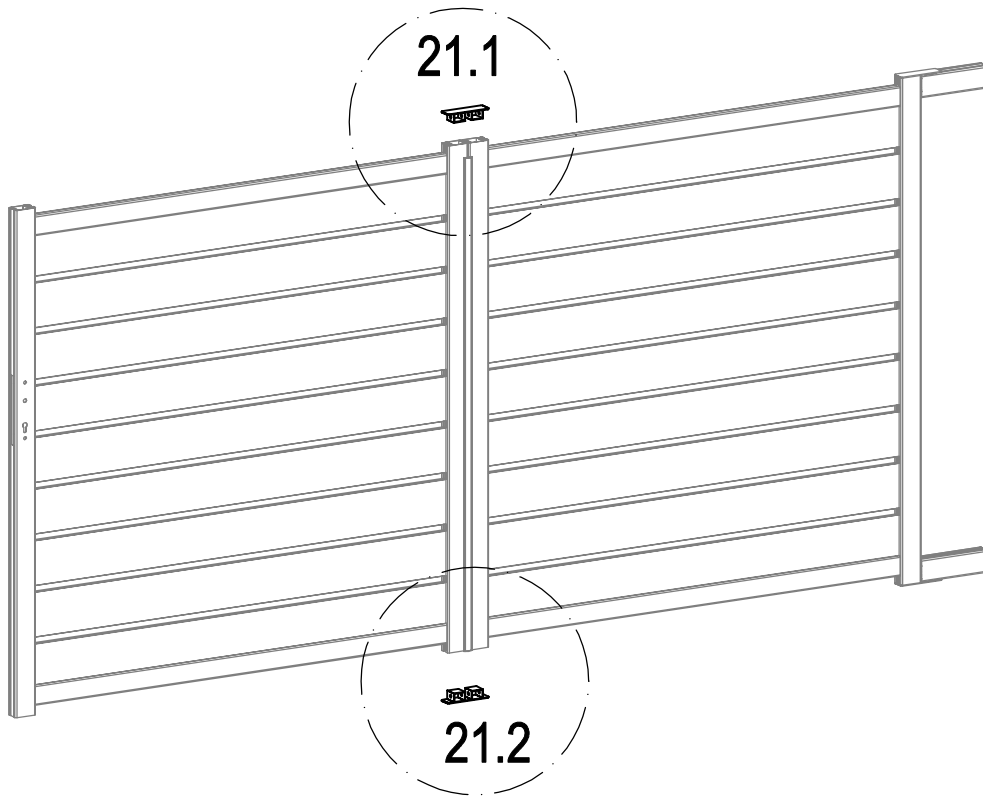

	AT-10	2
	VT-V30	2



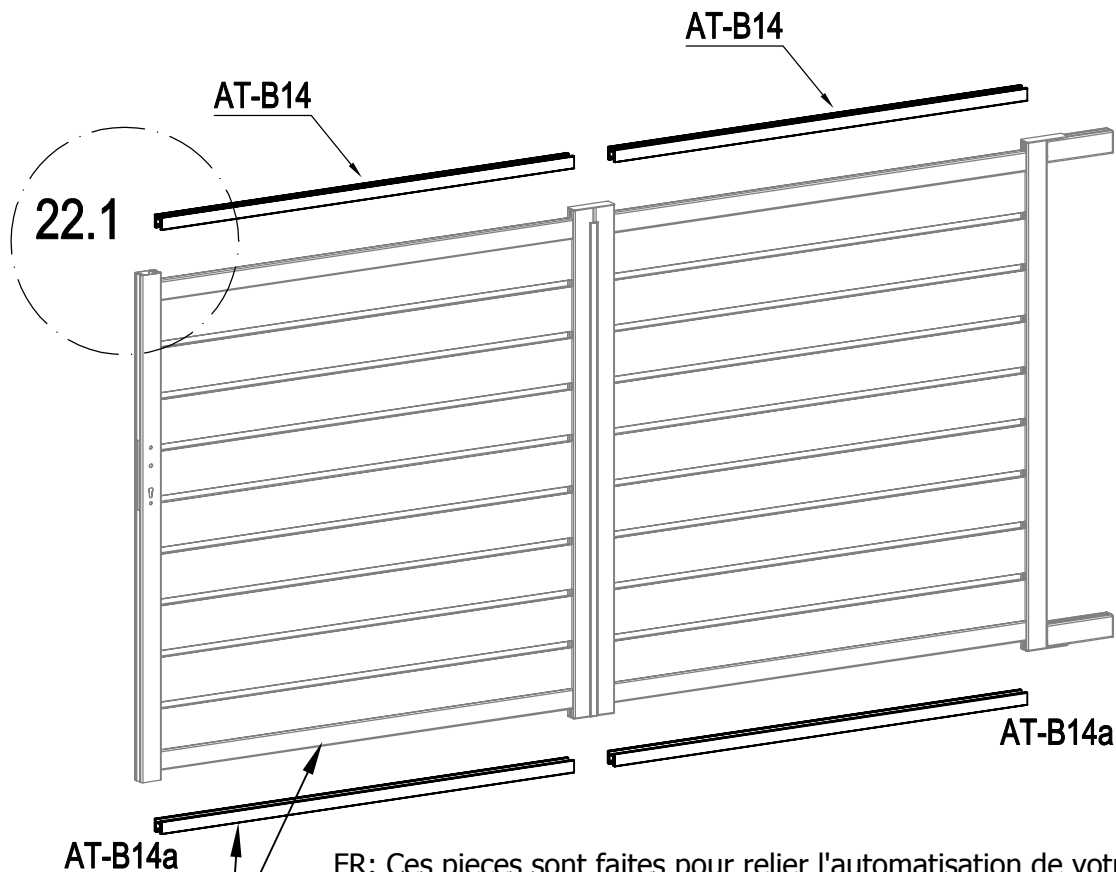

	AT-17	2
	VT-V33	2



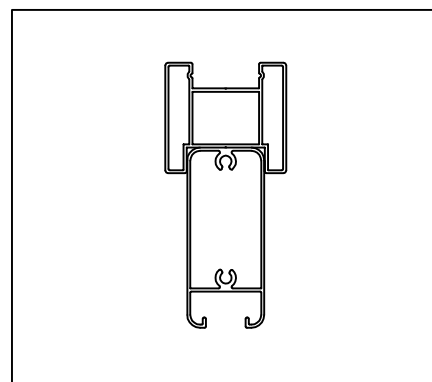
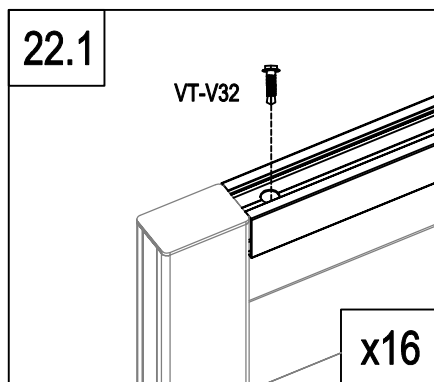
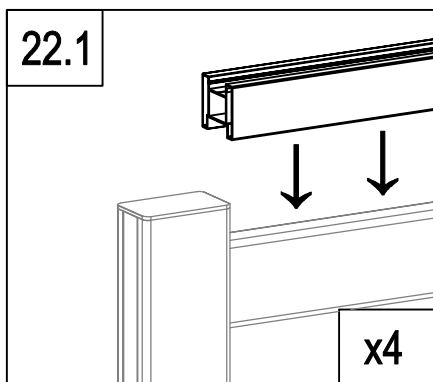

FR: Ces pieces sont faites pour relier l'automatisation de votre portail
 EN: These parts are made for connecting your gate's automation
 DE: Diese Teile sind für den Anschluss der Automatisierung Ihres Tores vorgesehen
 ES: Estas piezas estan hechas para conectar la automatizacion de su puerta
 IT: Queste parti sono realizzate per collegare l'automazione del vostro cancello
 NL: Deze onderdelen zijn gemaakt voor het aansluiten van de automatisering van uw poort.



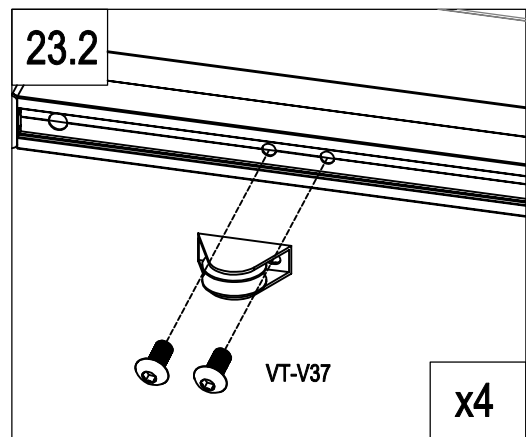
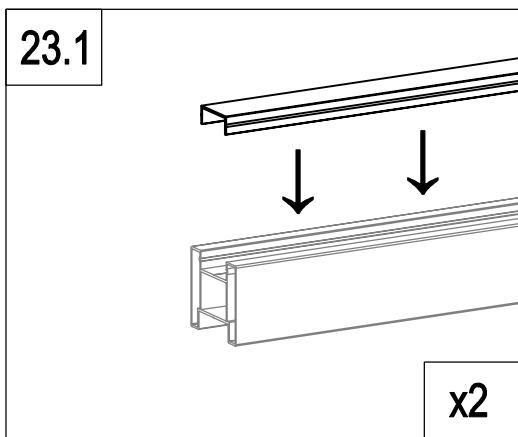
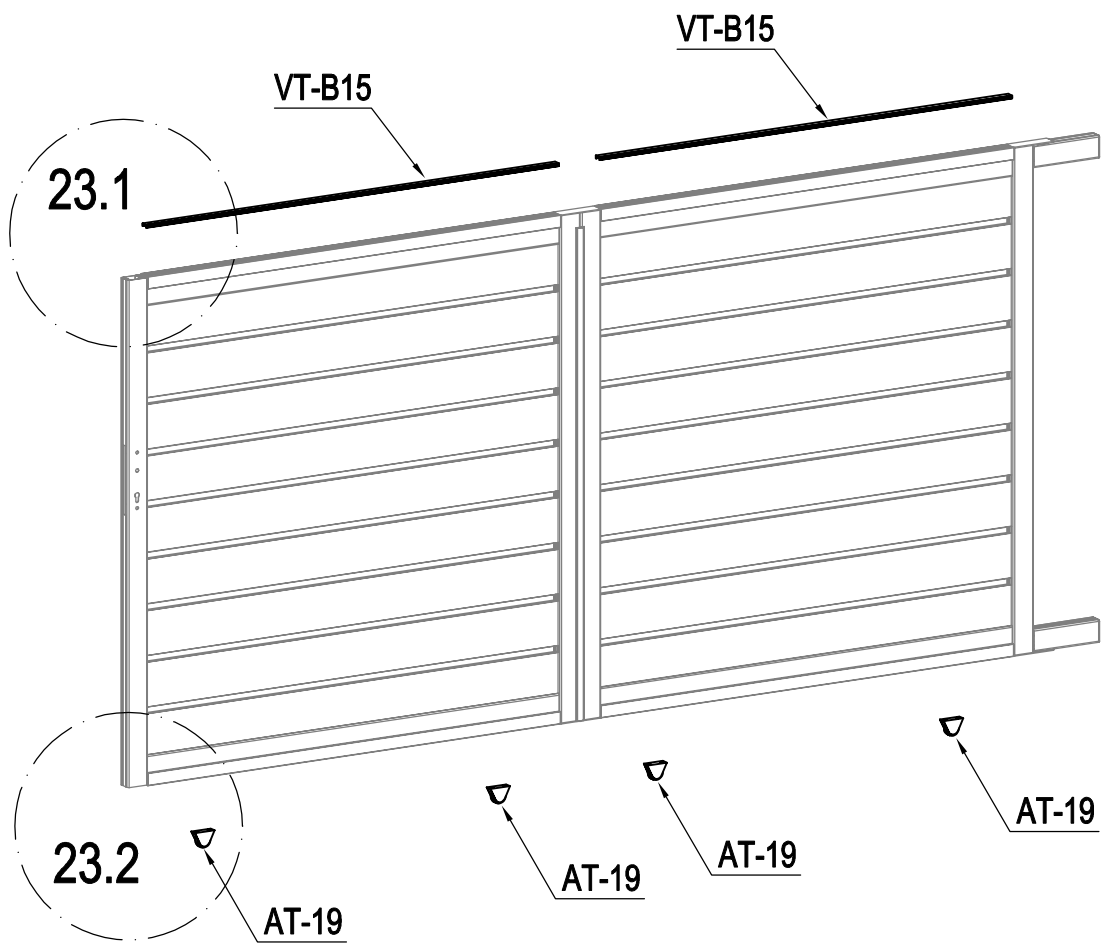

	AT-B14	2
	AT-B14a	2
	VT-V32	16

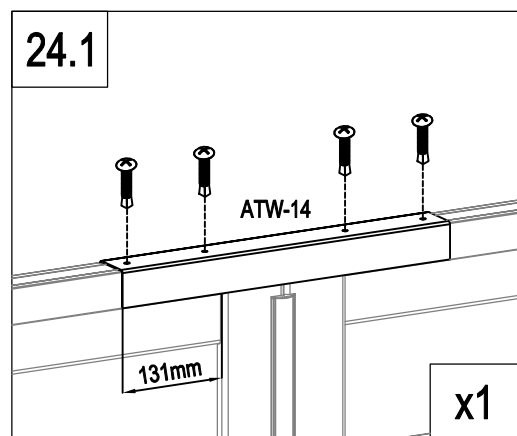
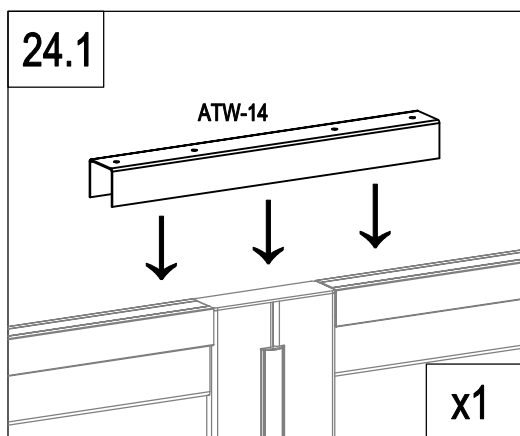
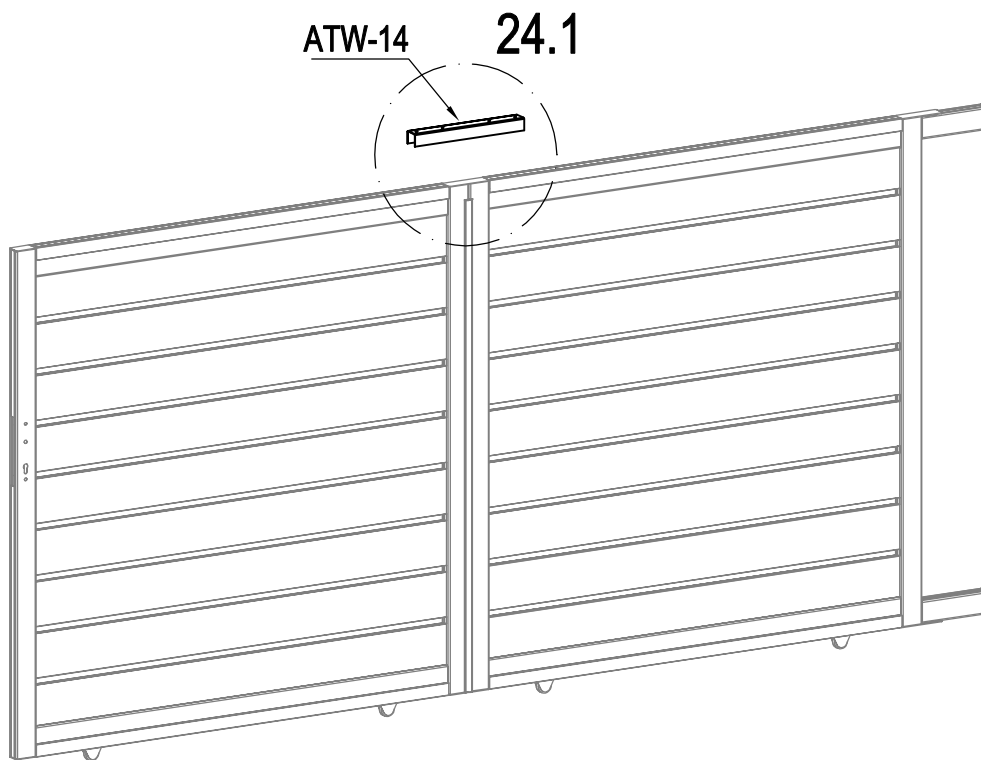

	VT-B15	2
	AT-19	4
	VT-V37	8



	ATW-14	1
	VT-V34	4

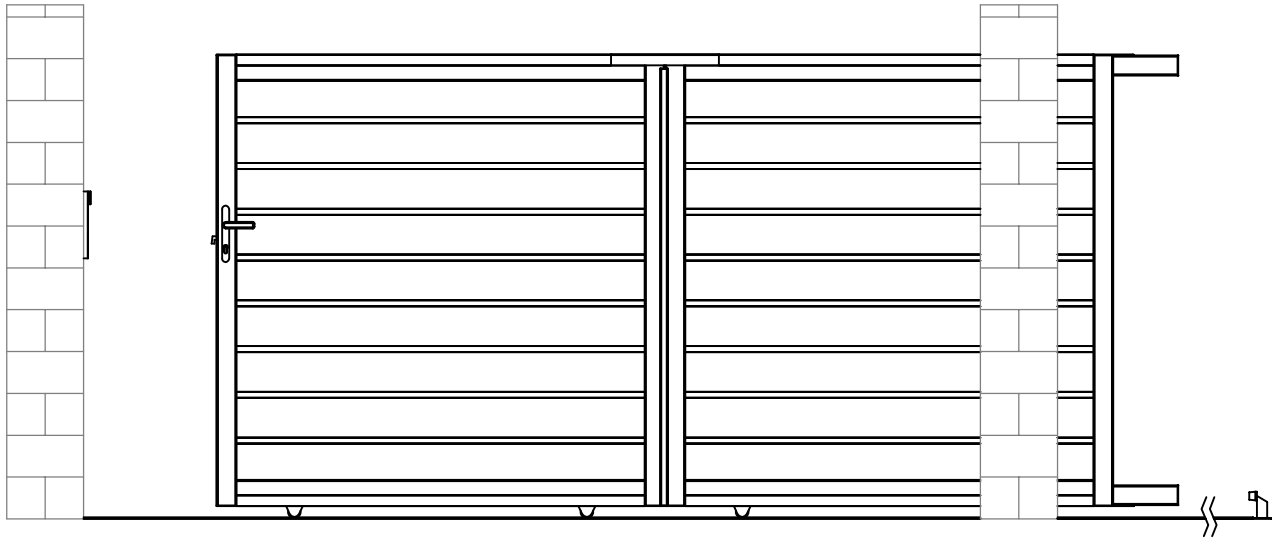

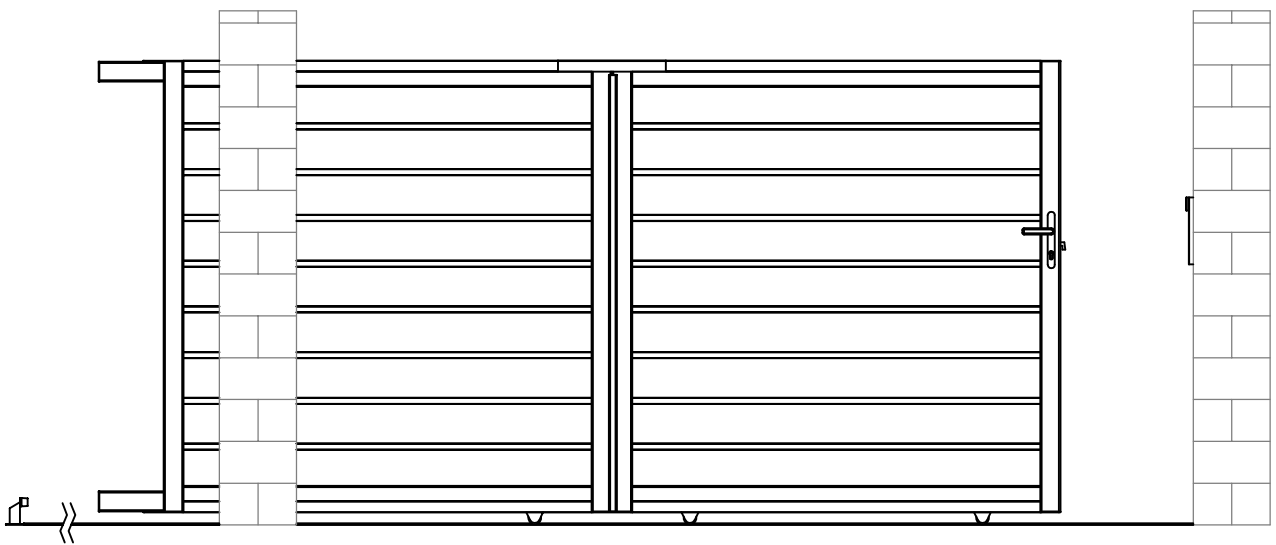

L : P25~30

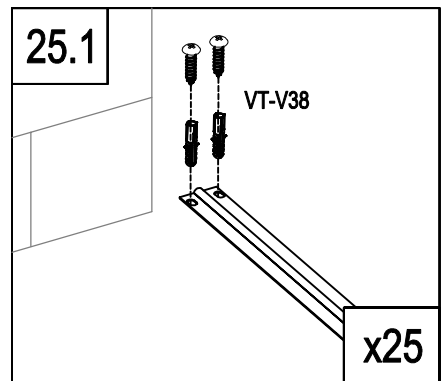
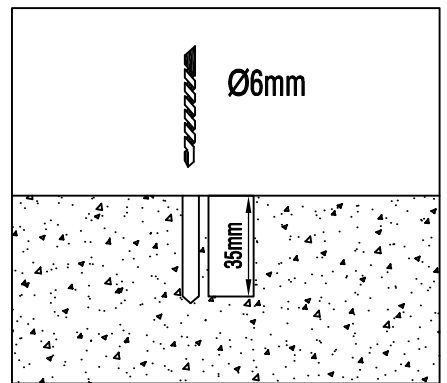
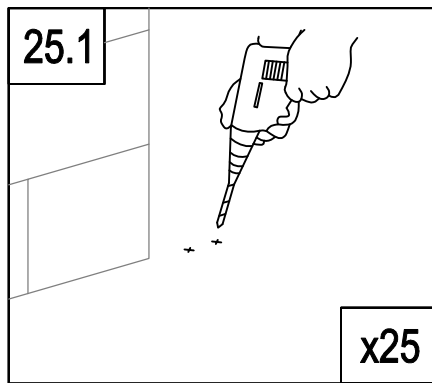
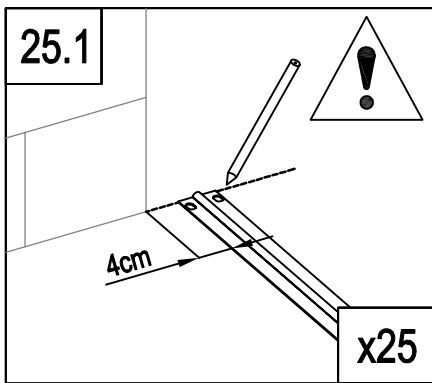
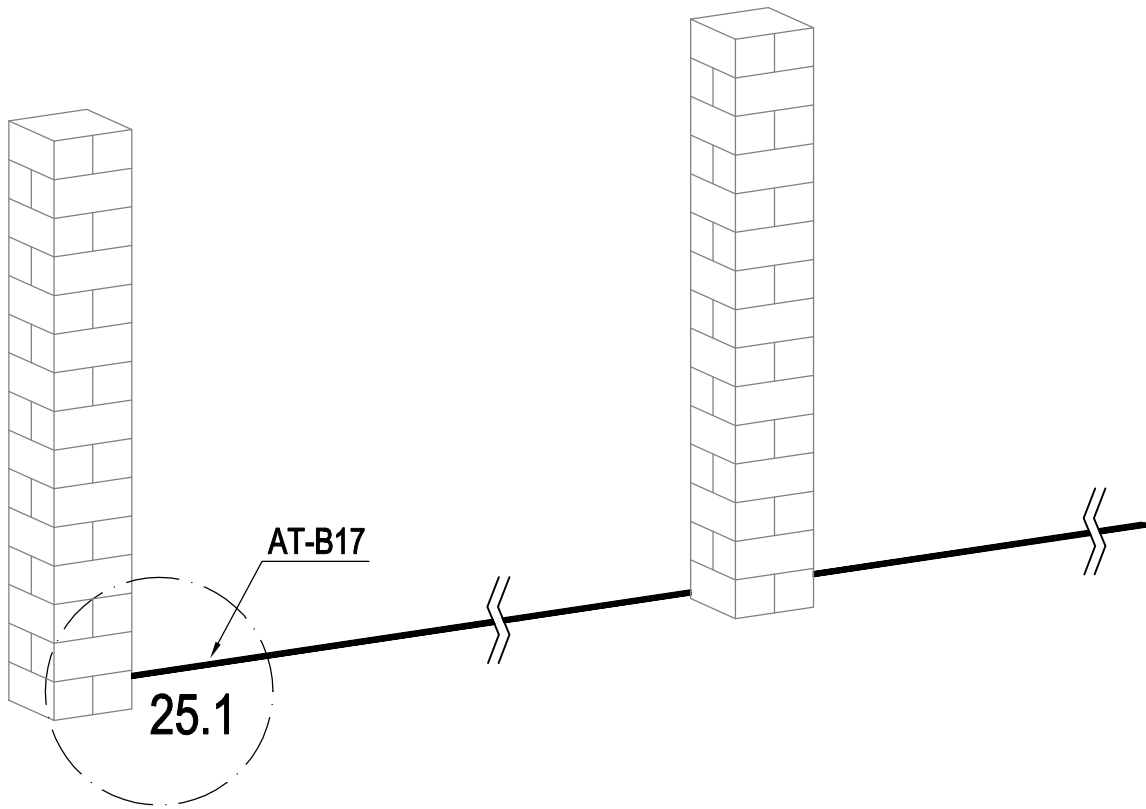

R : P31~36



	AT-B17	5
	VT-V38	50

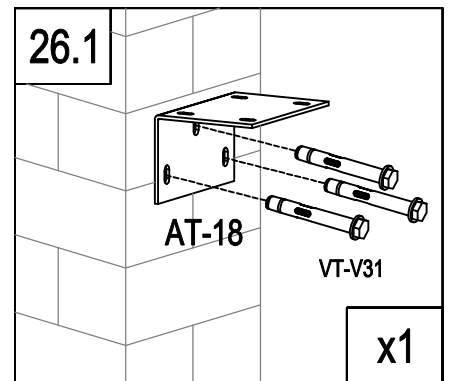
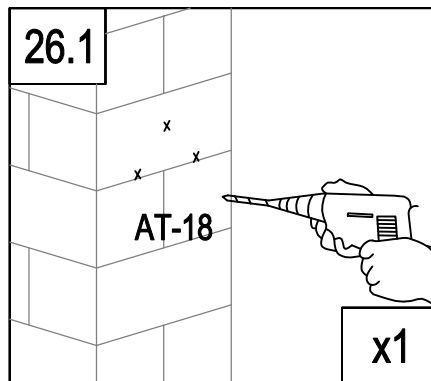
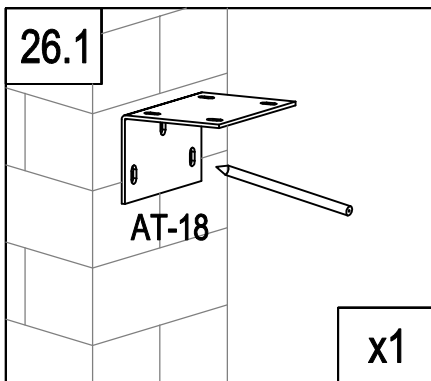
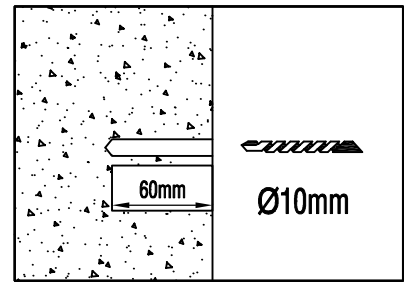
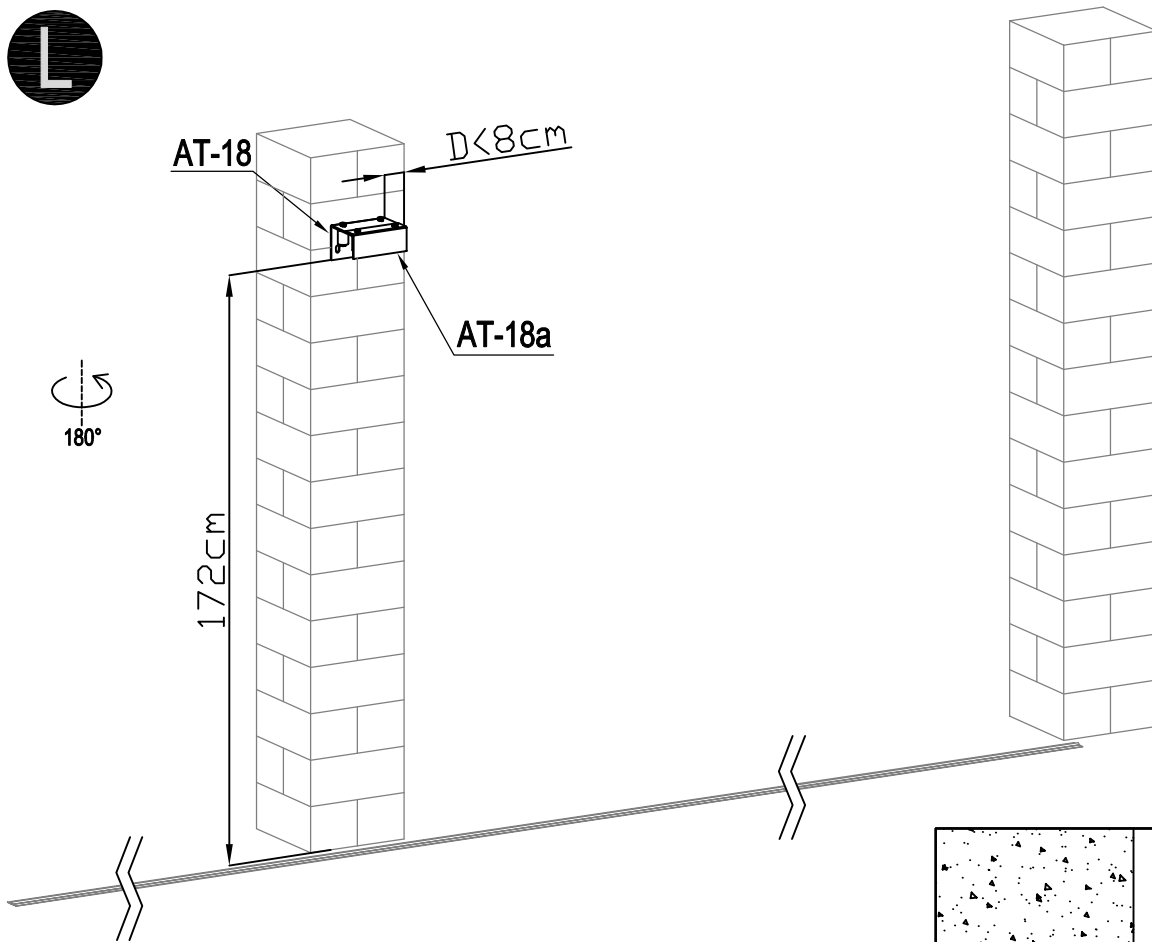

	AT-18	1
	AT-18a	1
	AT-20	4
	VT-V31	3

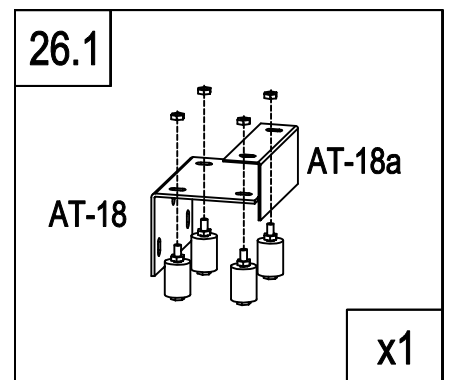
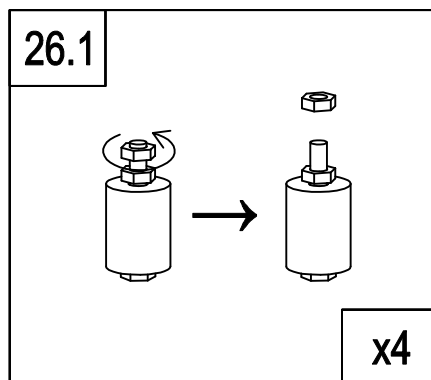

L

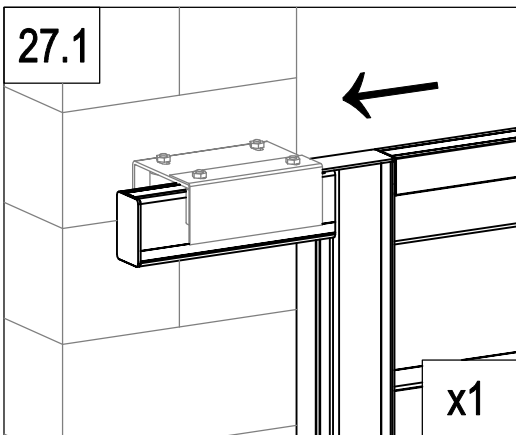
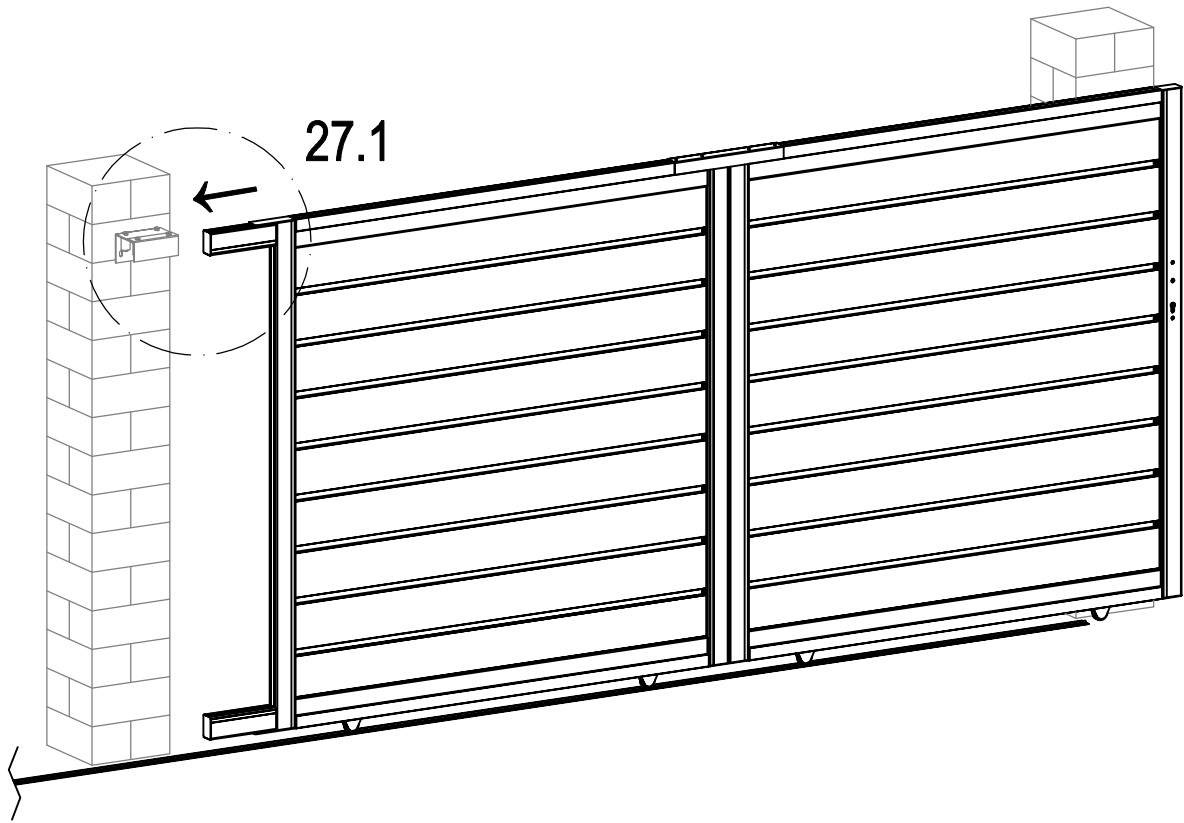

L

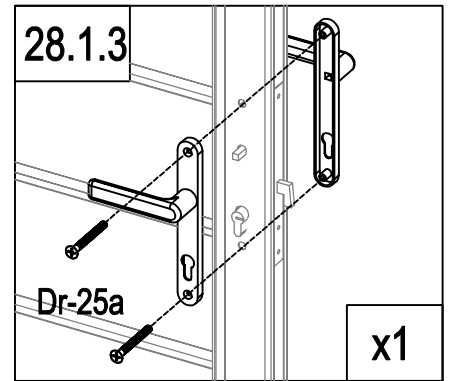
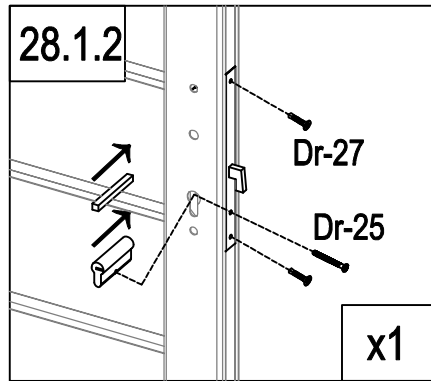
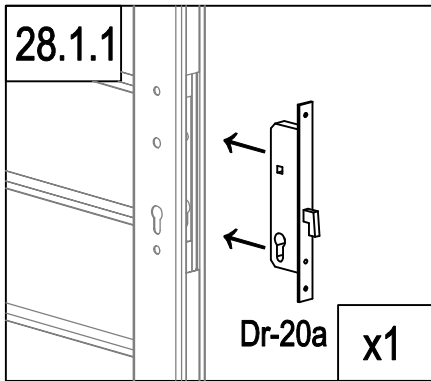
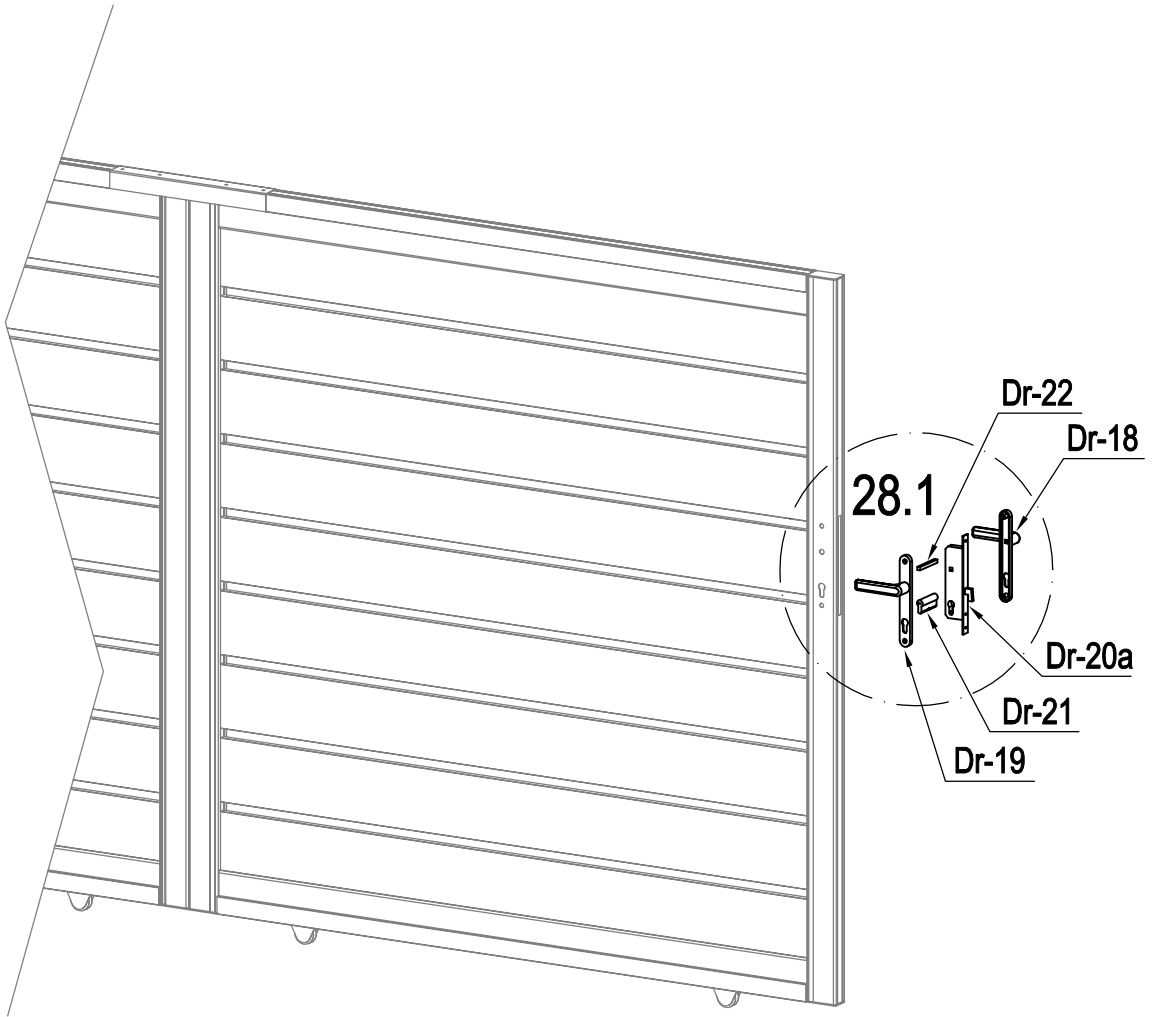



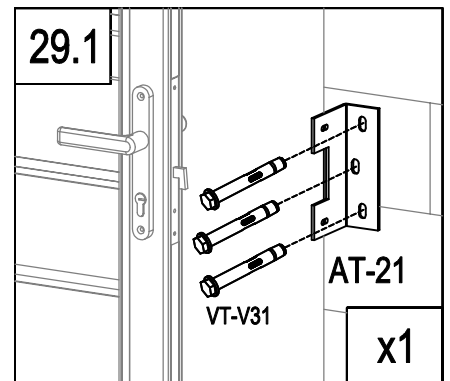
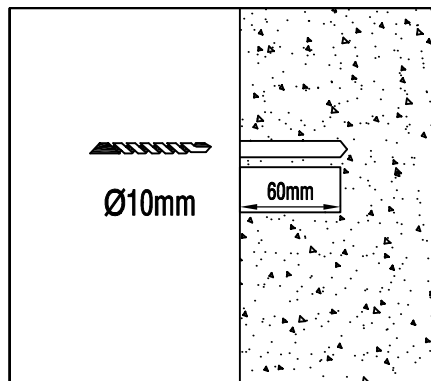
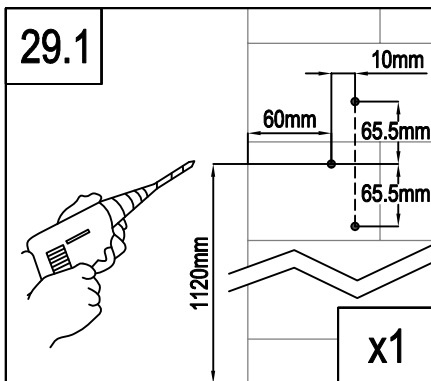
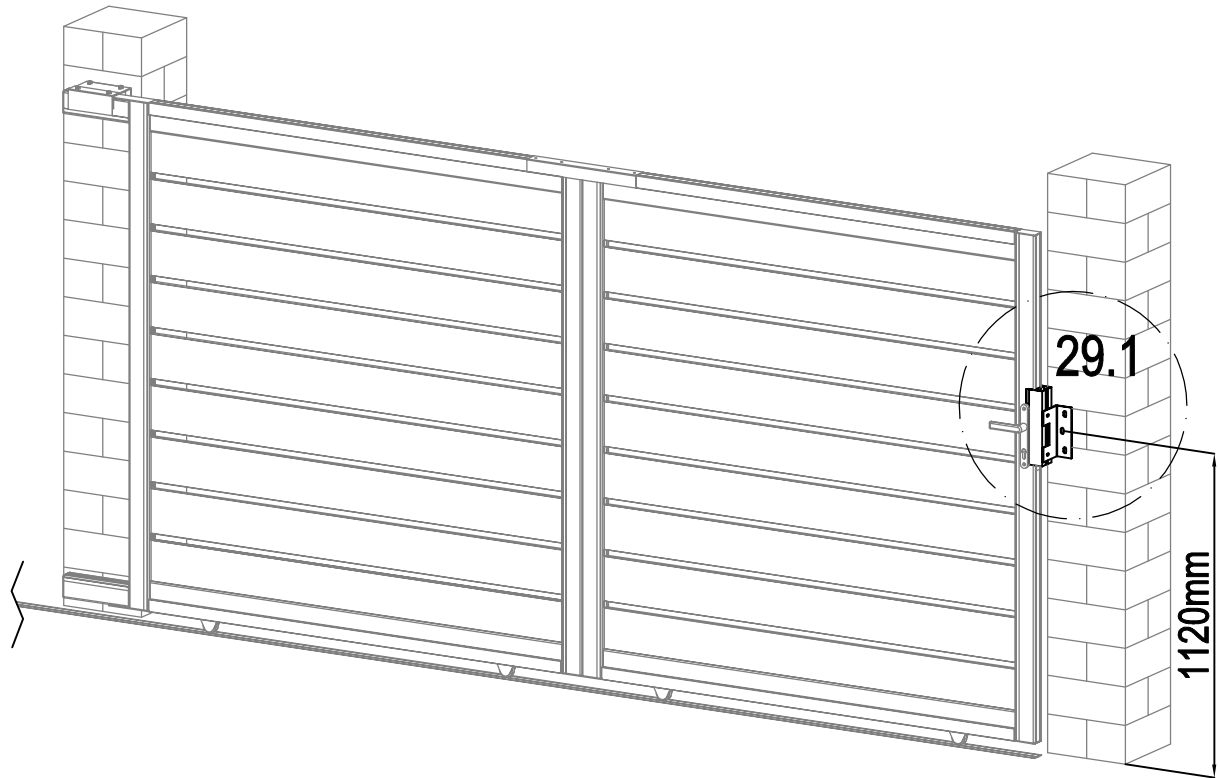

	Dr-20a	1
	Dr-21	1
	Dr-22	1
	Dr-25	1

	Dr-18	1
	Dr-19	1
	Dr-25a	2
	Dr-27	2

L



	AT-16	1
	AT-21	1
	VT-V36	2
	VT-V31	3
	AT-22J	3

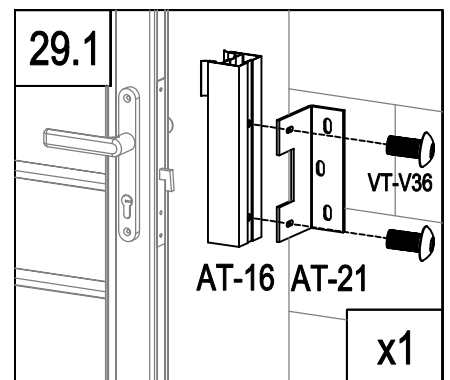
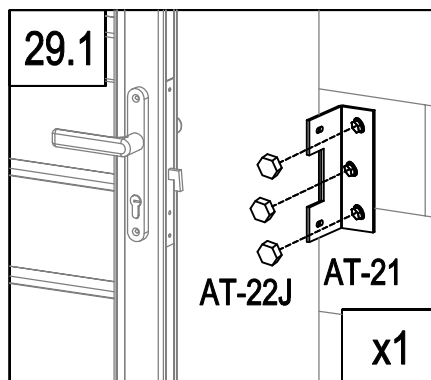

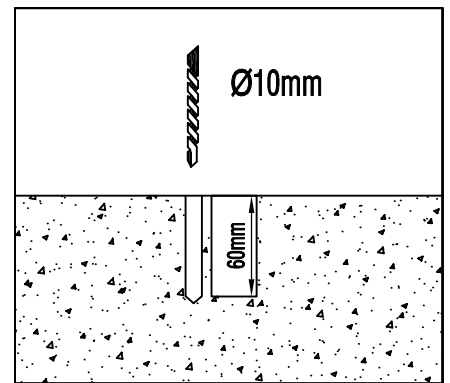
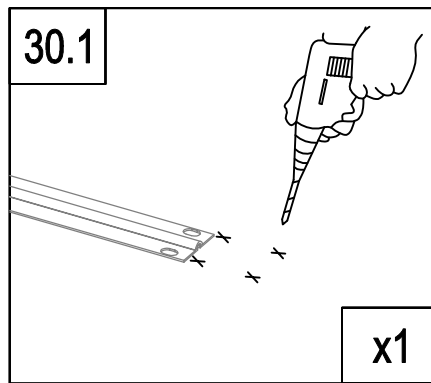
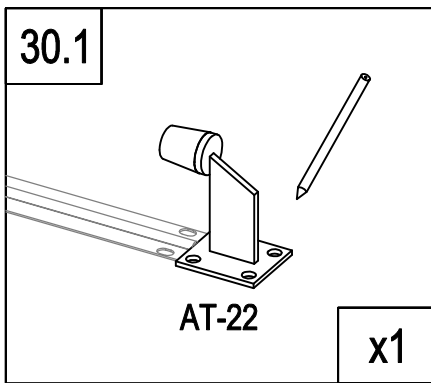
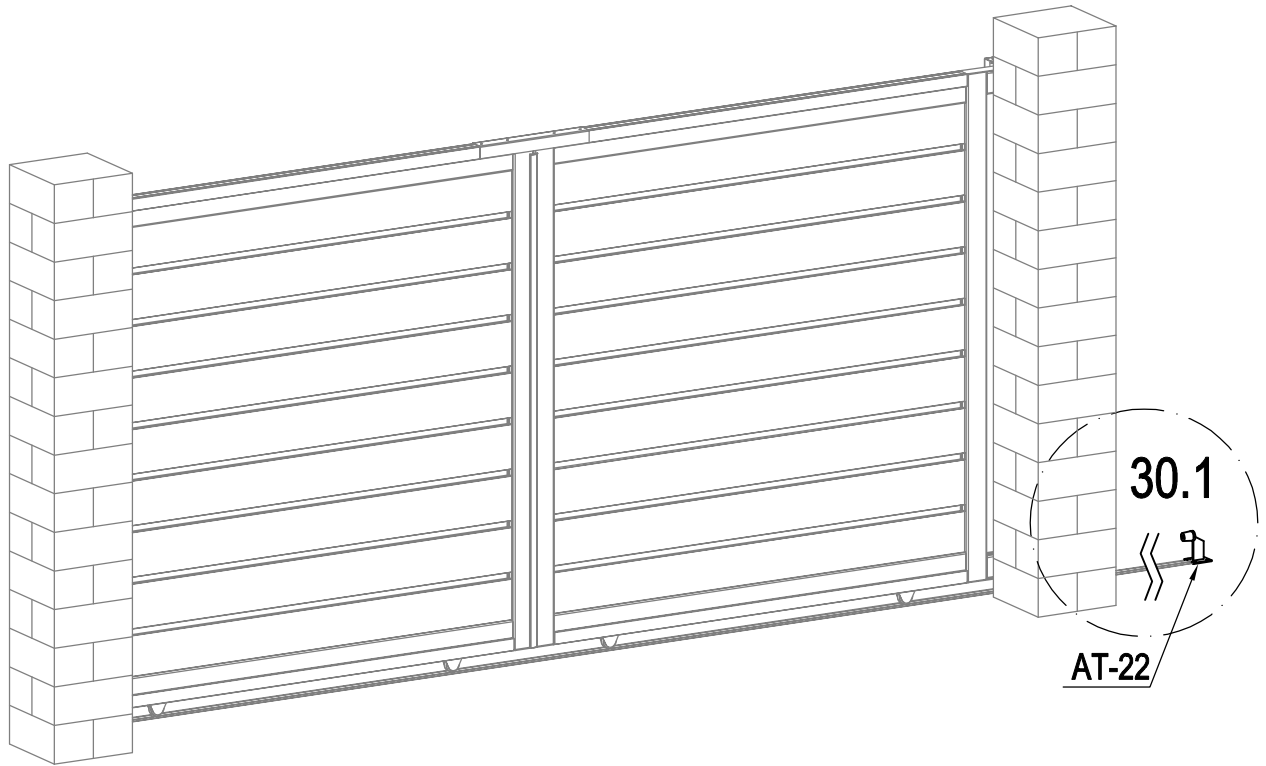

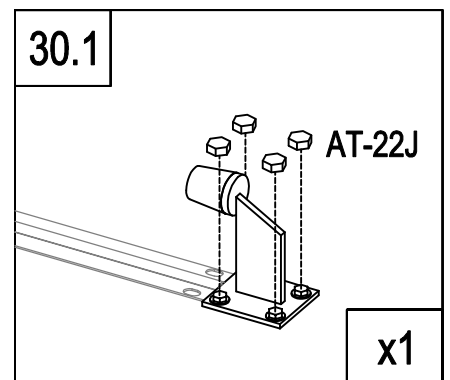
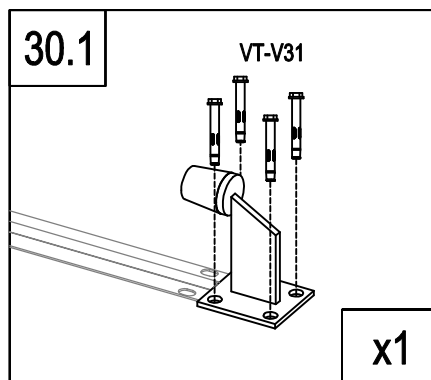

	AT-22	1
	VT-V31	4
	AT-22J	4

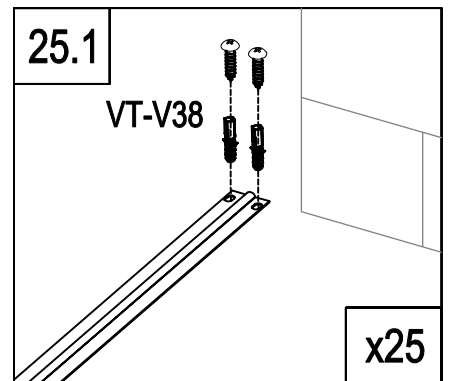
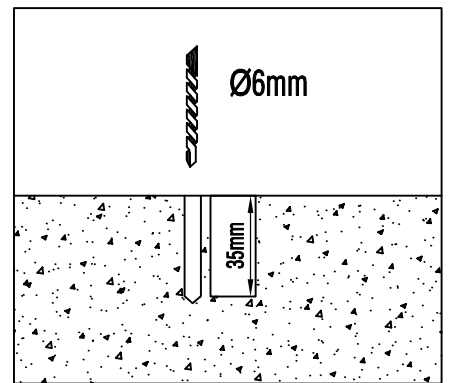
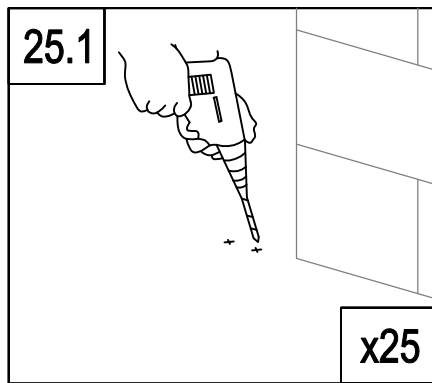
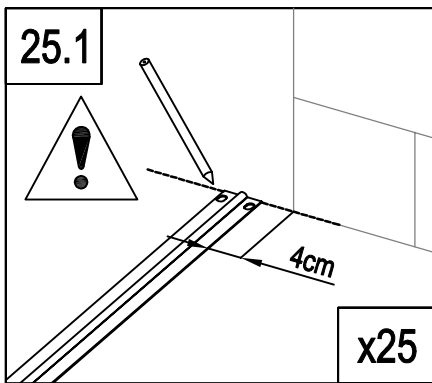
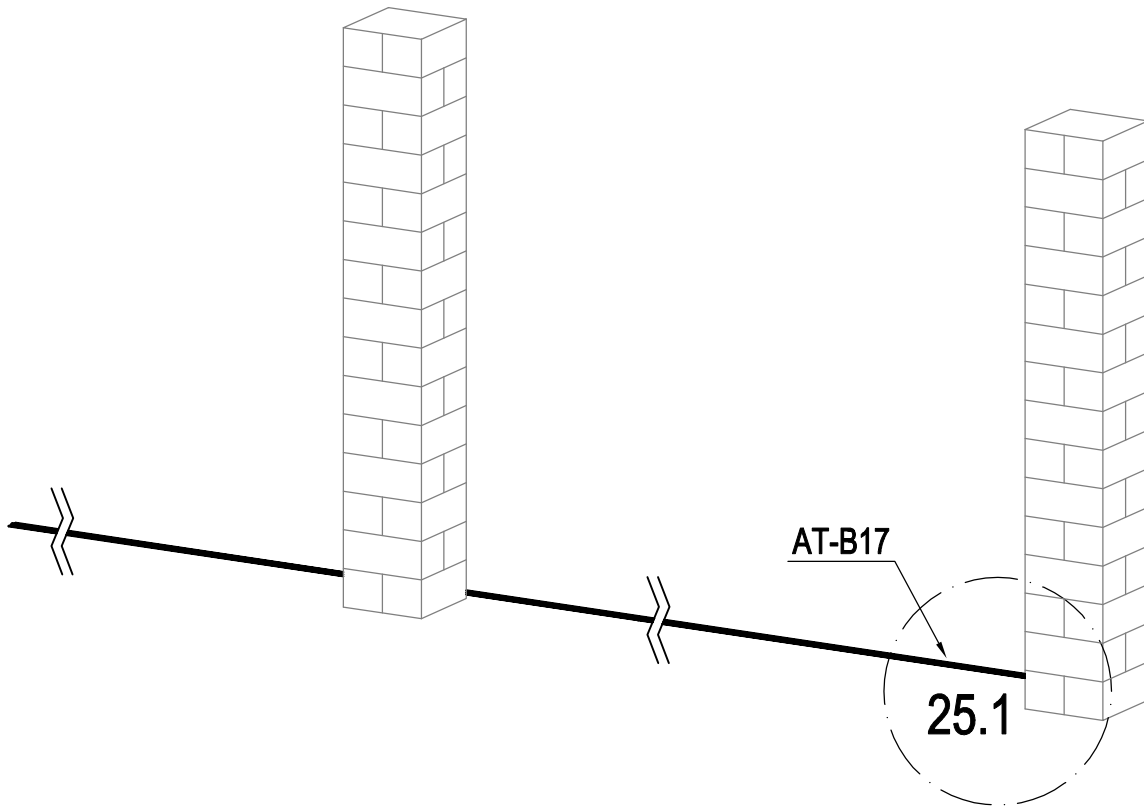



	AT-B17	5
	VT-V38	50

R

180°

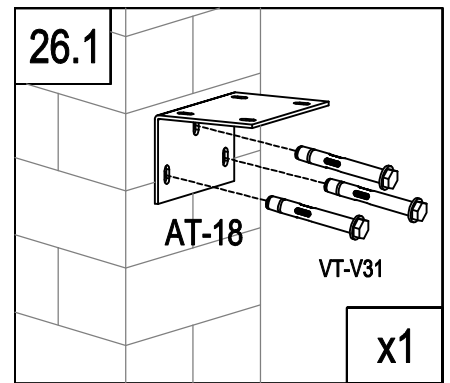
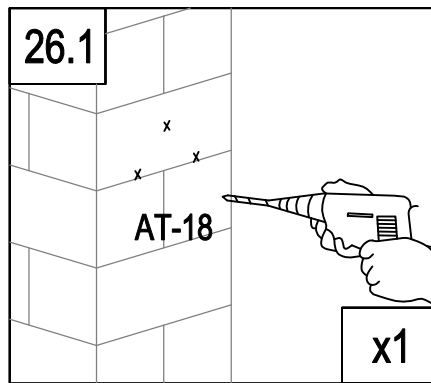
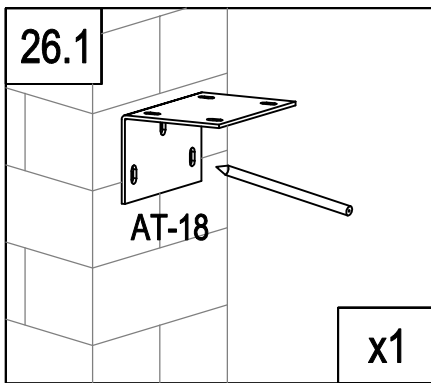
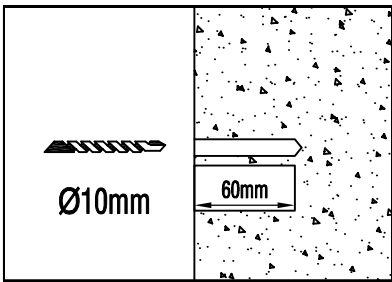
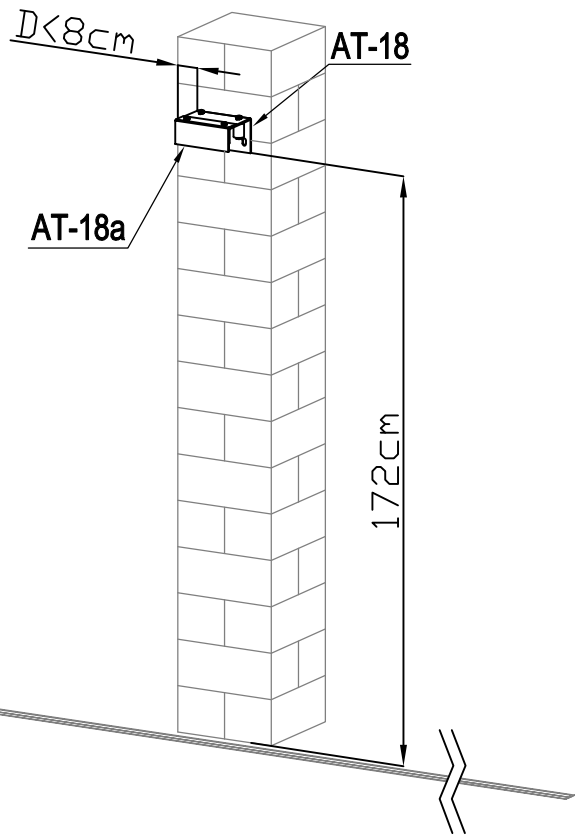
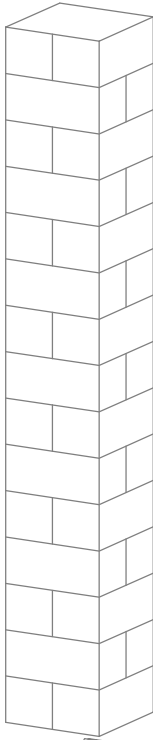

	AT-18	1
	AT-18a	1
	AT-20	4
	VT-V31	3

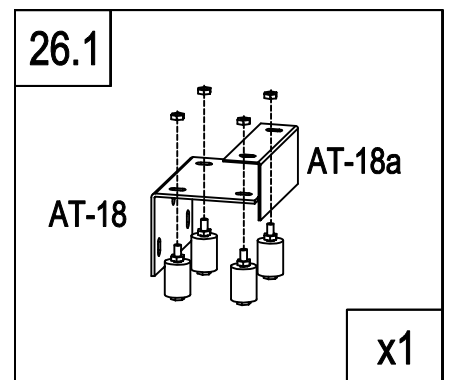
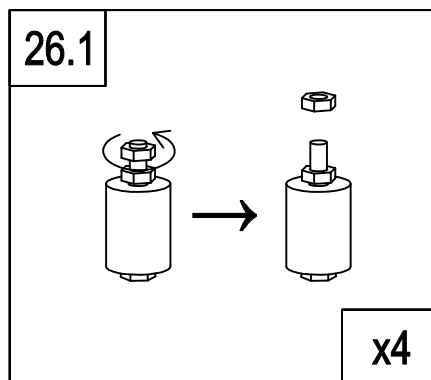

R

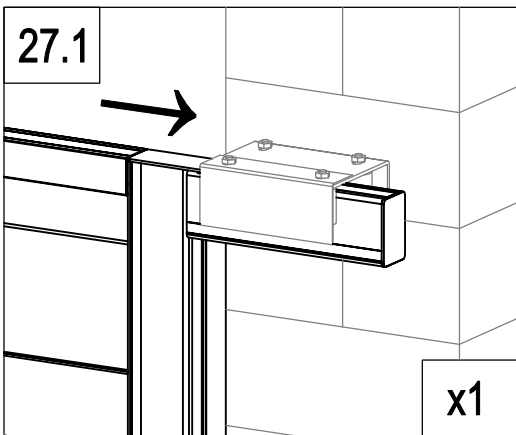
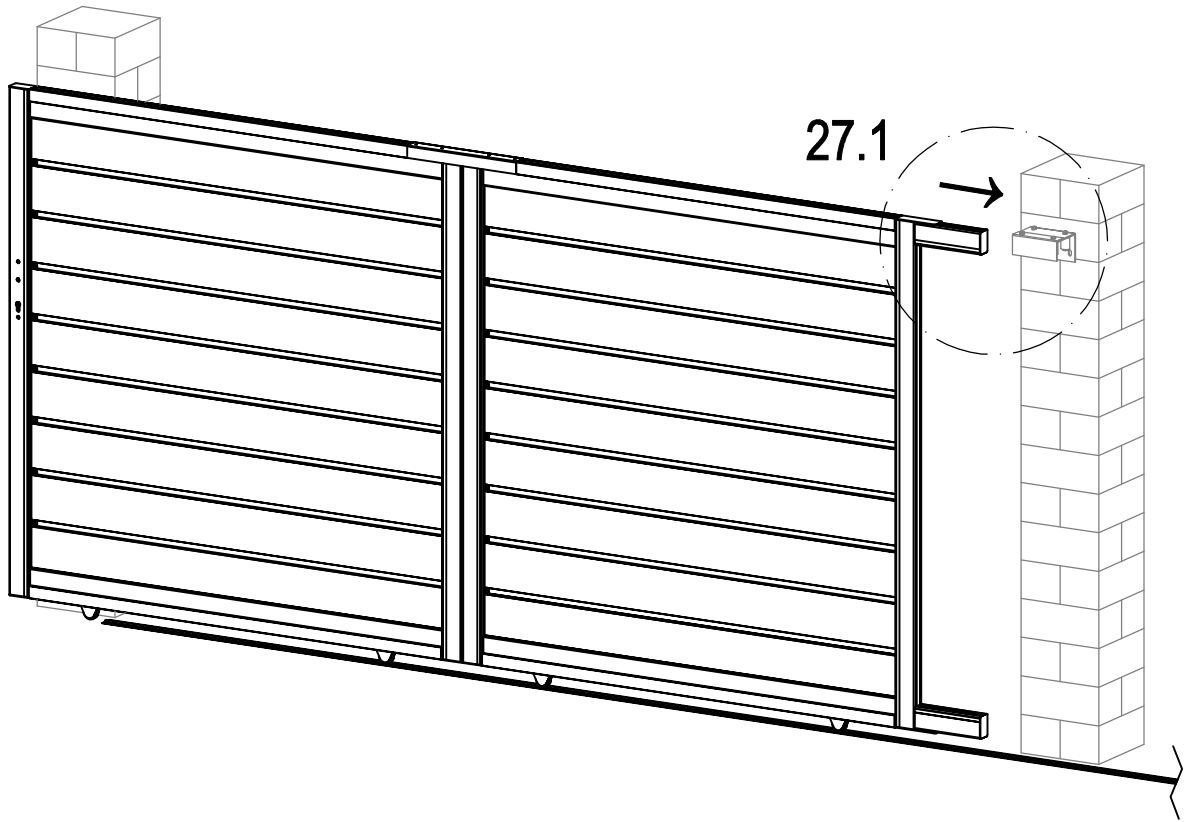

R

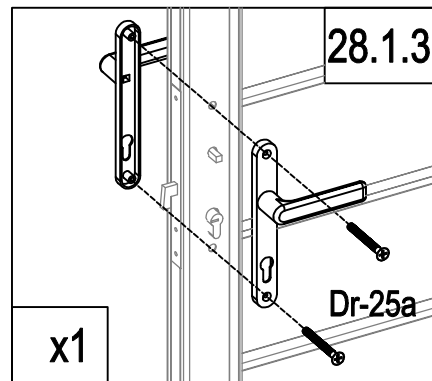
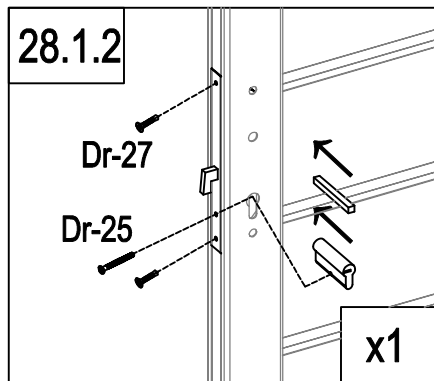
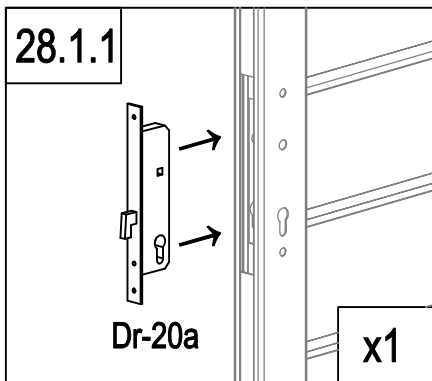
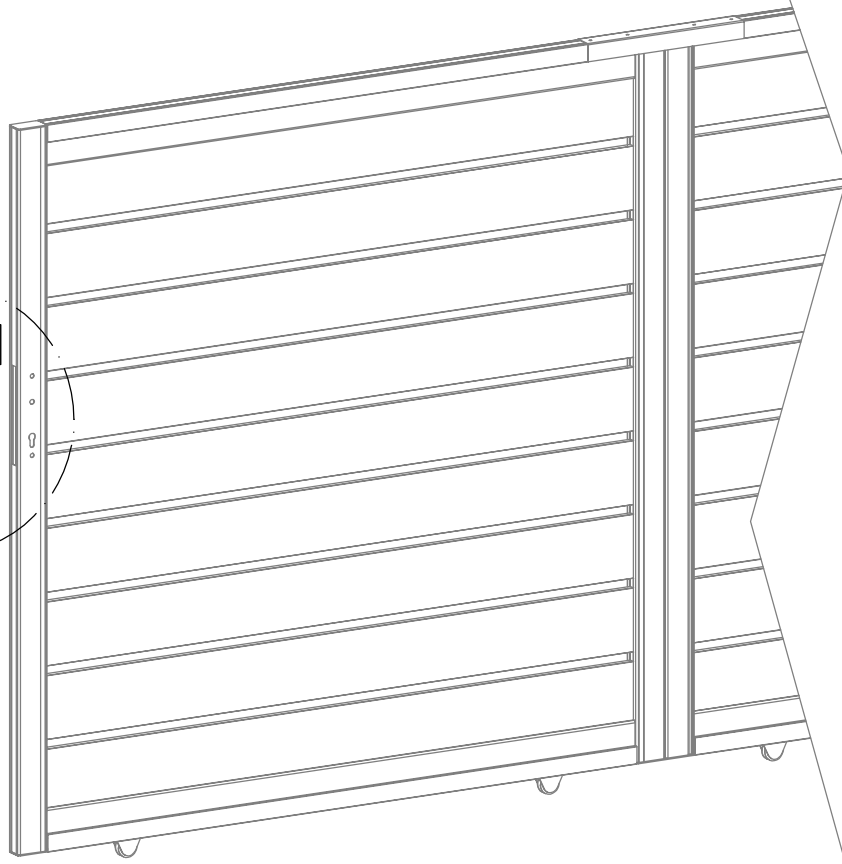
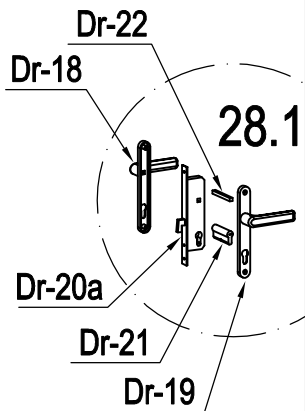

	Dr-20a	1
	Dr-21	1
	Dr-22	1
	Dr-25	1

	Dr-18	1
	Dr-19	1
	Dr-25a	2
	Dr-27	2

R

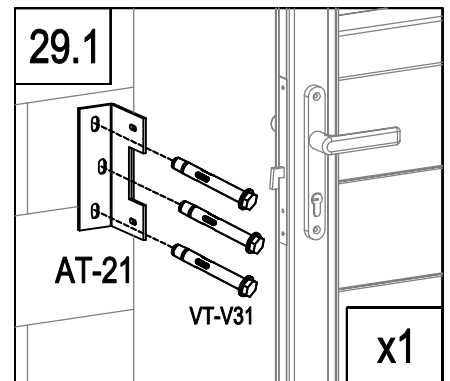
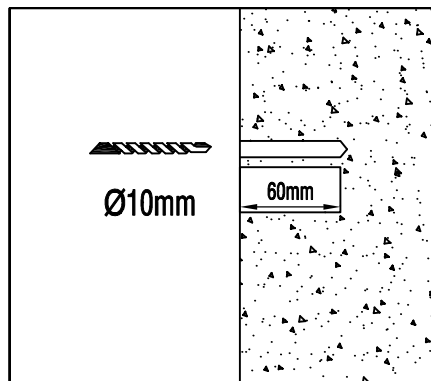
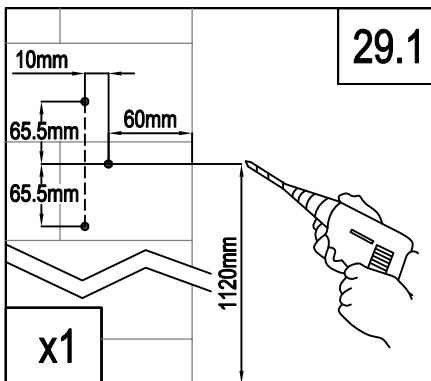
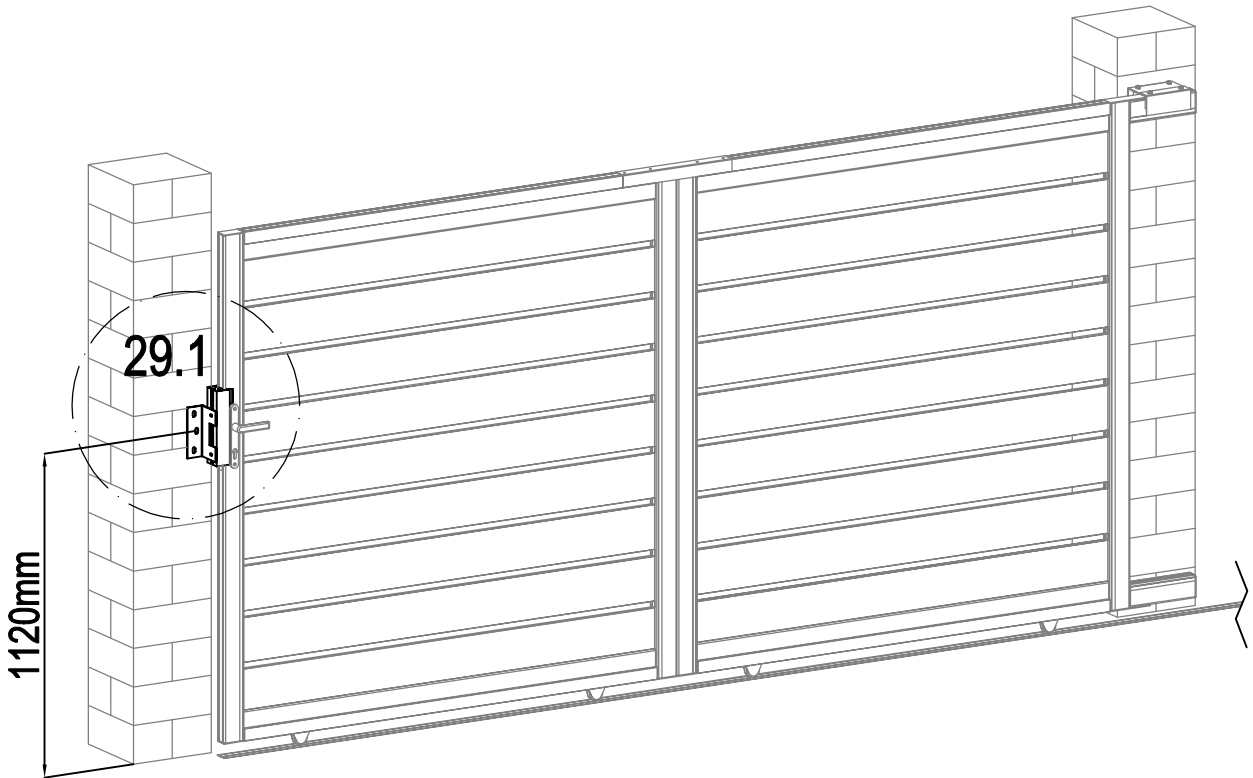

	AT-16	1
	AT-21	1
	VT-V36	2
	VT-V31	3
	AT-22J	3

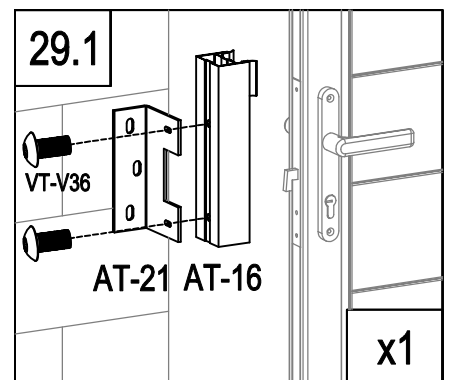
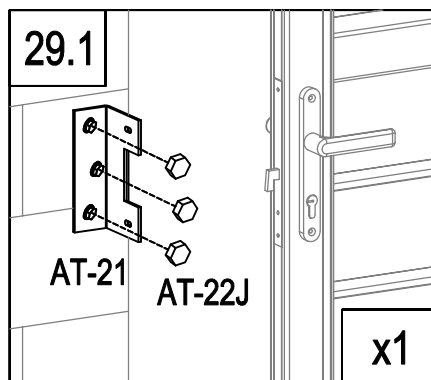

R

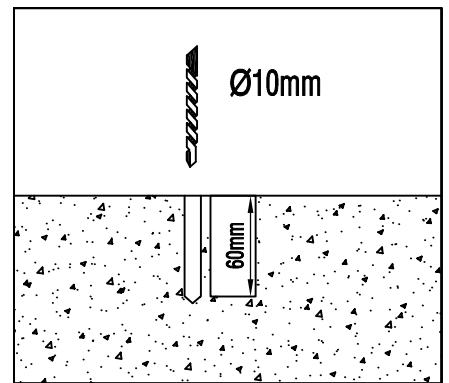
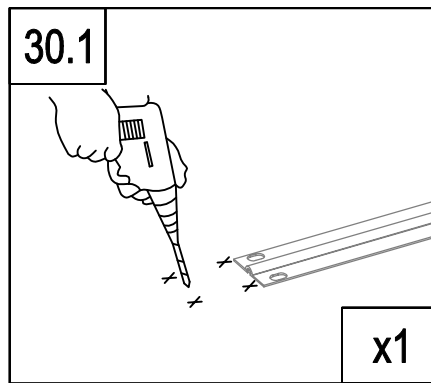
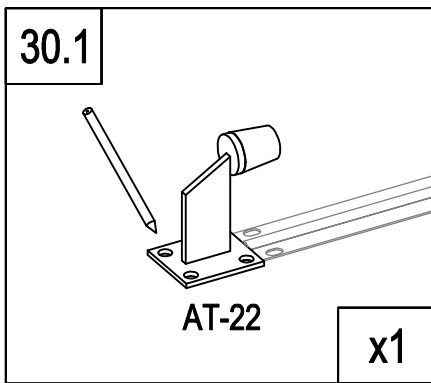
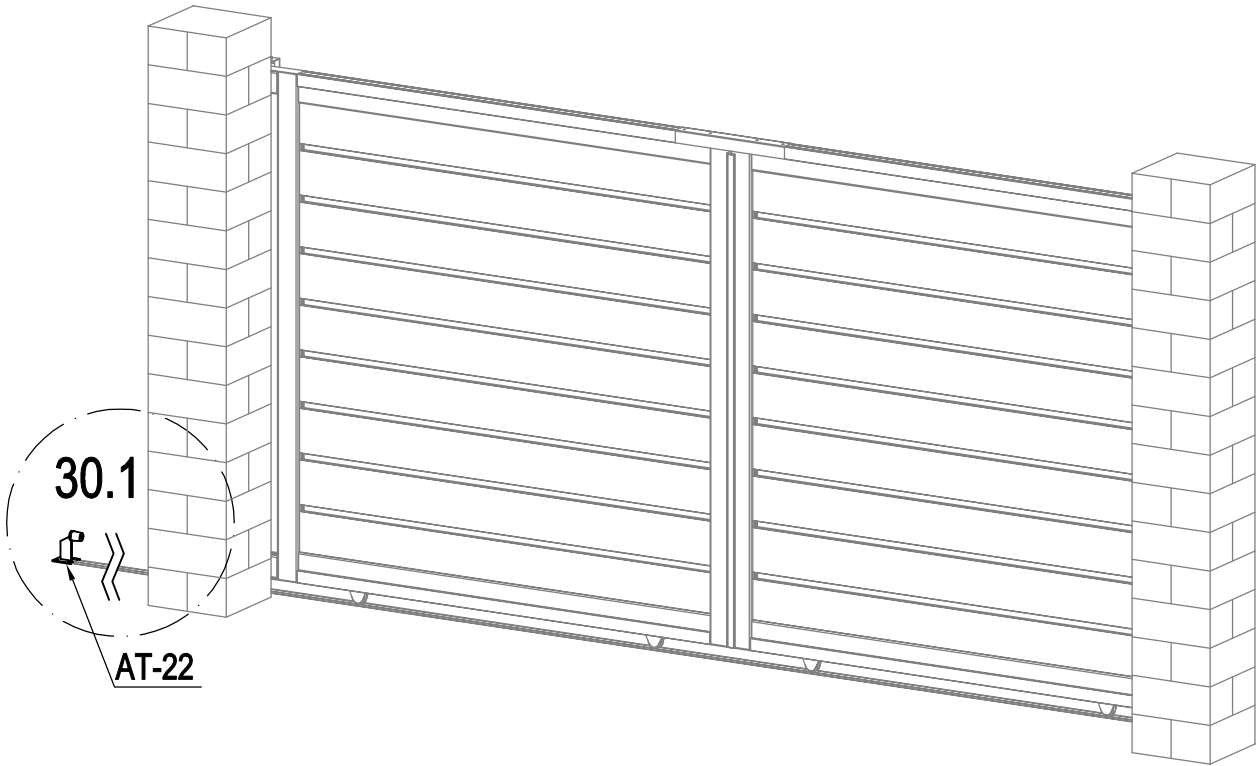

	AT-22	1
	VT-V31	4
	AT-22J	4

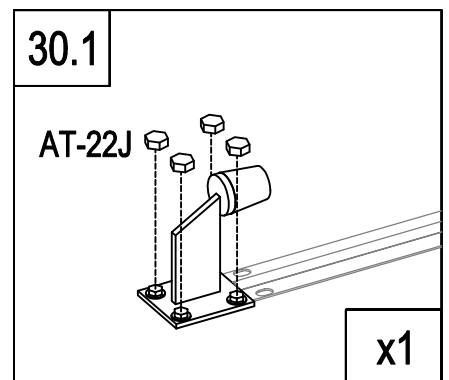
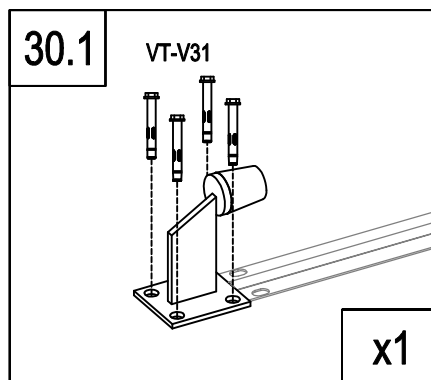

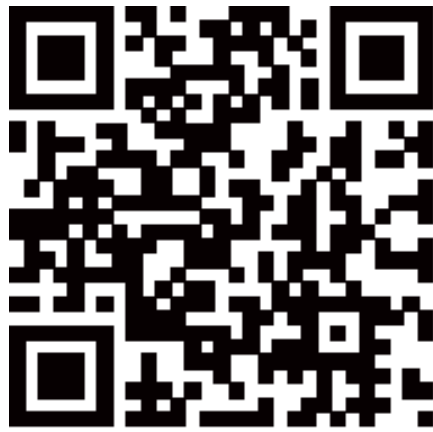

VS-Oct-2021

Imported by - Importé par
VENTE-UNIQUE.COM
9 Rue Jacquart 93310 Le Pré-Saint-Gervais
Made in China/ Fabriqué en Chine