

N625P318149

N625P318150

Product manual

Gebrauchsanweisung

Manuel du produit

Manual del producto

Manuale del prodotto

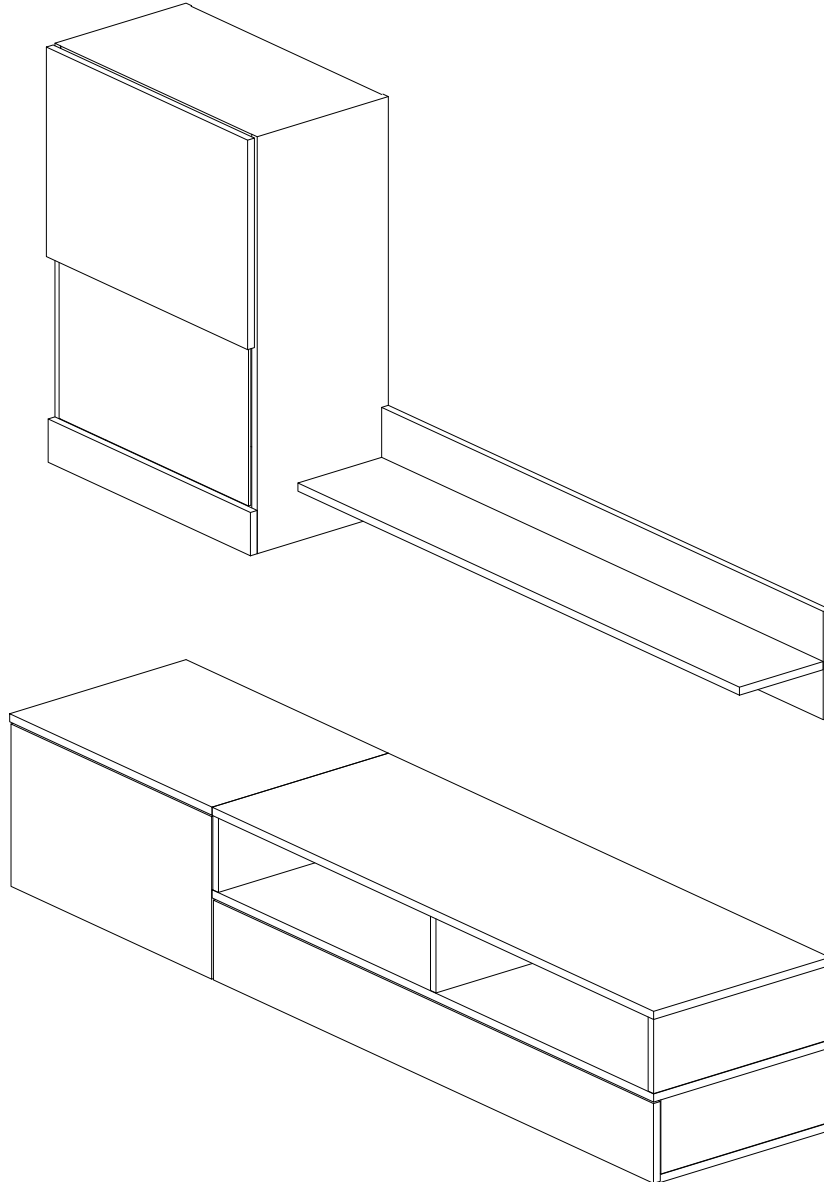

EN:Our product will be delivered to you in 2 packages.
The delivery times of these 2 packages may differ, please be patient and thank you for your understanding

FR:Notre produit vous sera livré en 2 colis.Les délais de livraison de ces 2 colis peuvent différer,soyez patient et merci de votre compréhension.

DE:Unser Produkt wird Ihnen in 2 Paketen geliefert.Die Lieferzeiten dieser 2 Paketekönnenabweichen,bitte haben Sie etwas Geduld und vielen Dank für Ihr Verständnis

IT:I nostri prodotti vengono trasportati in due pacchetti. I tempi di consegna dei due pacchetti sono diversi: abbiate pazienza e vi ringrazio per la vostra comprensione.

ES:Nuestro producto se entrega en dos paquetes. El tiempo de entrega de estos dos paquetes es diferente. Por favor, sea paciente. Gracias por su comprensión.



2PERS

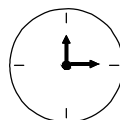

45 MIN

Tool Required Not Provided

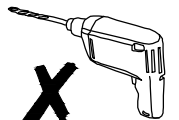
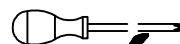
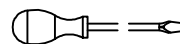



[DE]

Warnung: Lesen Sie die Anleitung vor dem Zusammenbau bitte vollständig durch. Überprüfen Sie, ob Sie alle auf den Seiten aufgeführten Komponenten und Werkzeuge haben.

Warnung: Legen Sie alle Teile auf eine ebene Fläche. Legen Sie eine weiche Decke oder Ähnliches darunter, um sie vor Kratzern oder Flecken zu schützen. Vermeiden Sie es, Komponenten über den Boden zu ziehen oder zu schieben.

Warnung: Überprüfen Sie regelmäßig alle Beschläge und Befestigungen, um sicherzustellen, dass sie sicher sind und um Unfälle zu vermeiden. Wenn Teile fehlen, kaputt, beschädigt oder abgenutzt sind, verwenden Sie das Produkt nicht weiter, bis es mit vom Hersteller autorisierten Teilen repariert wurde.

Warnung: Lassen Sie Kinder nicht auf die Möbel klettern, da dies zum Umkippen und zu schweren Verletzungen führen kann. Bauen Sie die Möbel außerhalb der Reichweite von Kindern zusammen.

Warnung: Stellen Sie die Möbel nicht in die Nähe von Feuerquellen oder heißen Gegenständen, um Brandgefahr zu vermeiden.

Warnung: Reinigen Sie die Möbel mit einem feuchten Tuch oder Alkohol. Verwenden Sie keine Reinigungsmittel mit ätzenden Chemikalien.

Warnung: Dieses Produkt ist mit einer Kippschutzvorrichtung ausgestattet. Bitte installieren Sie diese Vorrichtung unbedingt, um unnötige Verletzungen durch Umkippen zu vermeiden.

[EN]

Warning: Please read instructions fully before starting assembly. Check you have all the components and tools listed on pages.

Warning: Please place all parts on a flat surface. Place a soft blanket or similar underneath to protect against scratches or stains. Avoid dragging or sliding components across the floor.

Warning: Regularly check all fittings and fastenings to ensure they are secure and to prevent accidents. If any parts are missing, broken, damaged, or worn, discontinue use of the product until repairs have been made using factory authorized parts.

Warning: Do not allow children to climb on the furniture as this may result in tipping and serious personal injury. Assemble the furniture away from the reach of children.

Warning: Do not place furniture close to fire sources or high-temperature objects to avoid the risk of fire

Warning: Clean furniture with a damp cloth or alcohol, avoid using cleaning agents containing corrosive chemicals.

Warning: This product is equipped with an anti-tilt device. Please be sure to install this device to prevent unnecessary injuries caused by tipping.

[FR]

Avertissement : Veuillez lire entièrement les instructions avant de commencer l'assemblage. Vérifiez que vous disposez de tous les composants et outils répertoriés sur les pages.

Avertissement : Veuillez placer toutes les pièces sur une surface plane. Placez une couverture douce ou similaire en dessous pour les protéger des rayures ou des taches. Évitez de faire glisser les composants sur le sol.

Avertissement : Vérifiez régulièrement tous les raccords et fixations pour vous assurer qu'ils sont bien fixés et pour éviter les accidents. Si des pièces manquent, sont cassées, endommagées ou usées, cessez d'utiliser le produit jusqu'à ce que des réparations aient été effectuées à l'aide de pièces autorisées par l'usine.

Avertissement : Ne laissez pas les enfants grimper sur les meubles car cela pourrait entraîner un basculement et des blessures graves. Assemblez les meubles hors de portée des enfants.

Avertissement : Ne placez pas les meubles à proximité de sources de feu ou d'objets à haute température pour

éviter tout risque d'incendie.

Avertissement : Nettoyez les meubles avec un chiffon humide ou de l'alcool, évitez d'utiliser des produits de nettoyage contenant des produits chimiques corrosifs.

Avertissement : Ce produit est équipé d'un dispositif anti-basculement. Assurez-vous d'installer ce dispositif pour éviter les blessures inutiles causées par un basculement.

[IT]

Attenzione: leggere attentamente le istruzioni prima di iniziare il montaggio. Verificare di avere tutti i componenti e gli strumenti elencati nelle pagine.

Attenzione: posizionare tutte le parti su una superficie piana. Posizionare una coperta morbida o simile sotto per proteggere da graffi o macchie. Evitare di trascinare o far scivolare i componenti sul pavimento.

Attenzione: controllare regolarmente tutti i raccordi e i dispositivi di fissaggio per assicurarsi che siano sicuri e per prevenire incidenti. Se alcune parti sono mancanti, rotte, danneggiate o usurate, interrompere l'uso del prodotto fino a quando non siano state eseguite le riparazioni utilizzando parti autorizzate dalla fabbrica.

Attenzione: non consentire ai bambini di arrampicarsi sui mobili poiché ciò potrebbe causare ribaltamenti e gravi lesioni personali. Montare i mobili lontano dalla portata dei bambini.

Attenzione: non posizionare i mobili vicino a fonti di fuoco o oggetti ad alta temperatura per evitare il rischio di incendio

Attenzione: pulire i mobili con un panno umido o alcol, evitare di utilizzare detergenti contenenti sostanze chimiche corrosive.

Attenzione: questo prodotto è dotato di un dispositivo antiribaltamento. Assicurarsi di installare questo dispositivo per prevenire lesioni inutili causate dal ribaltamento.

[ES]

Advertencia: Lea las instrucciones completamente antes de comenzar el montaje. Compruebe que tiene todos los componentes y herramientas que se enumeran en las páginas.

Advertencia: Coloque todas las piezas sobre una superficie plana. Coloque una manta suave o algo similar debajo para protegerlas de rayones o manchas. Evite arrastrar o deslizar los componentes por el piso.

Advertencia: Verifique regularmente todos los accesorios y fijaciones para asegurarse de que estén seguros y evitar accidentes. Si falta alguna pieza, está rota, dañada o desgastada, deje de usar el producto hasta que se hayan realizado las reparaciones con piezas autorizadas de fábrica.

Advertencia: No permita que los niños se suban a los muebles, ya que esto puede provocar que se vuelquen y lesiones personales graves. Monte los muebles fuera del alcance de los niños.

Advertencia: No coloque los muebles cerca de fuentes de fuego u objetos de alta temperatura para evitar el riesgo de incendio.

Advertencia: Limpie los muebles con un paño húmedo o alcohol, evite usar agentes de limpieza que contengan químicos corrosivos.

Advertencia: Este producto está equipado con un dispositivo antivuelco. Asegúrese de instalar este dispositivo para evitar lesiones innecesarias causadas por vuelcos.

Parts List

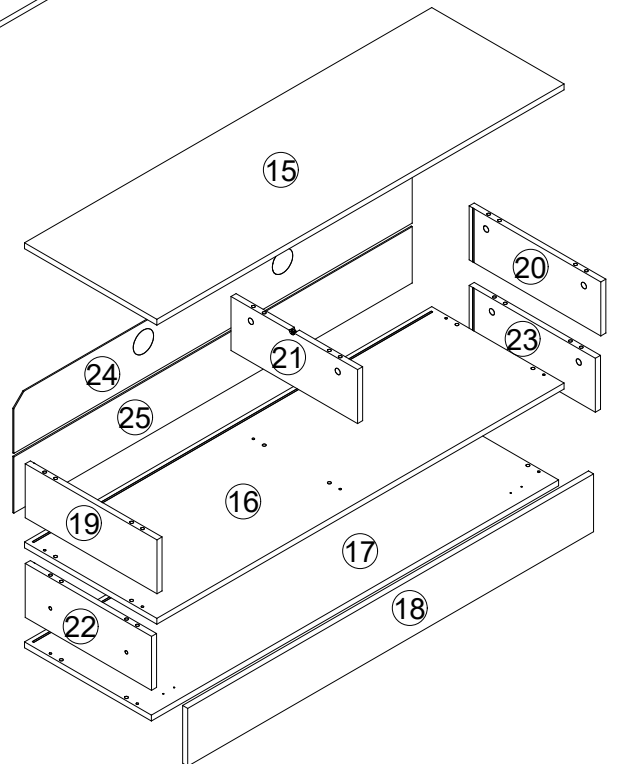
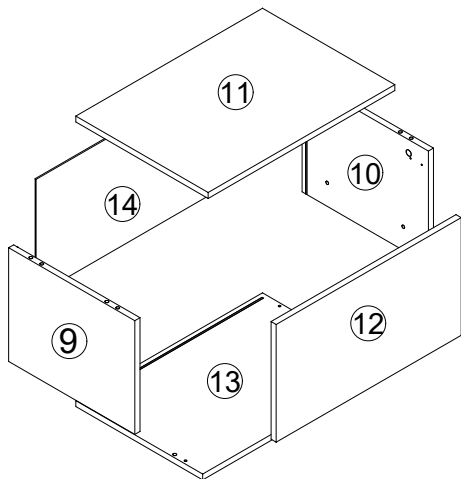
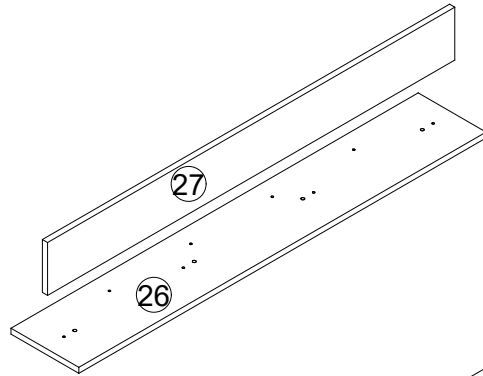
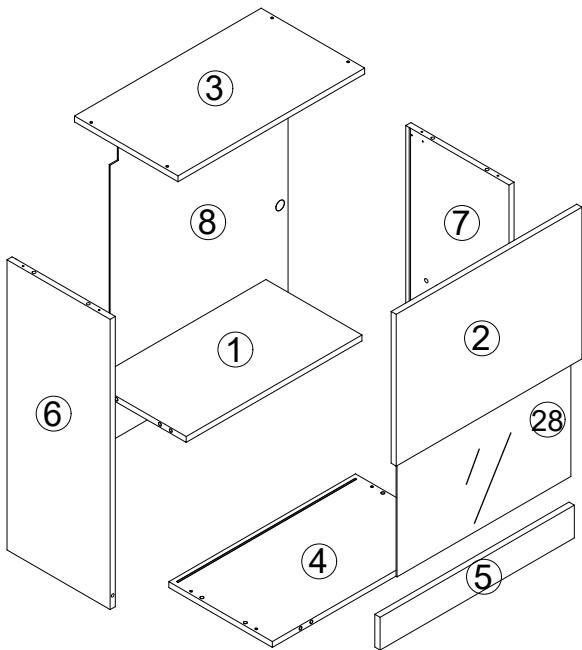



EN_QUICKFIT: Tighten quickfit until shoulder is flush with panel. Do not overtighten or undertighten.

FR_RACCORD RAPIDE: Faites serrer le raccord rapide jusqu'à ce que l'épaulement soit parfaitement encastré dans le panneau. Il ne faut ni trop serrer ni insuffisamment serrer.

ES_QUICKFIT: Apriete quickfit hasta que el hombro se descargue con el panel. NO lo sobreapriete ni lo apriete poco.

DE_QUICKFIT: Ziehen Sie den Quickfit fest, bis die Schulter mit der Platte bündig ist. Bitte nicht zu fest oder zu schwach anziehen.

IT_MONTAGGIO RAPIDO: Stringere il montaggio rapido fino a quando la spalla è a filo con il pannello, non stringere troppo o troppo poco.

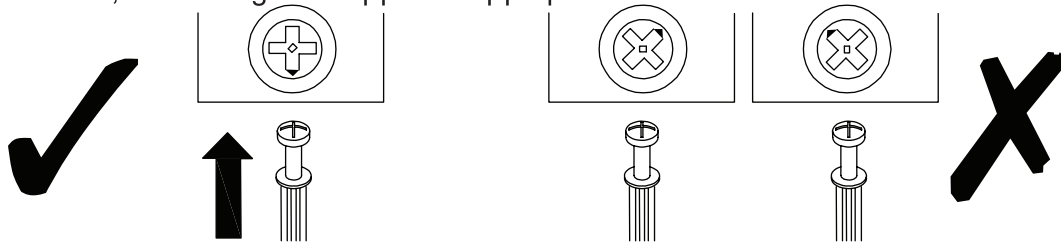

EN_CAM LOCK: When fitting cam lock, ensure starting position is correct before you insert connecting quickfit.

FR_SERRURE BATTEUSE: Avant d'insérer la serrure batteuse, veillez à la bonne orientation avant d'insérer le raccord rapide.

ES_CIERRE DE LA CÁMARA: Cuando instale el cierre de la cámara, asegúrese de que la posición de inicio es correcta antes de que inserte el quickfit conector.

DE_CAM-LOCK: Achten Sie bei der Montage des Cam-Locks auf die richtige Ausgangsposition, bevor Sie den Quickfit einsetzen.

IT_BLOCCAGGIO A CAMMA: Quando si monta il bloccaggio a camma, assicurarsi che la posizione iniziale sia corretta prima di inserire il montaggio rapido di collegamento.



EN_Quickfit head should be in the centre of the cam lock when the two panels are joined.

Cam lock should be inserted before quickfit.

FR_Lorsque les deux panneaux sont assemblés, la tête du raccord rapide doit reposer au centre de la serrure batteuse. Il faut insérer la serrure batteuse avant le raccord rapide.

ES_El cabezal del quickfit debe estar en el centro del cierre de la cámara cuando se unan los dos paneles.

Se debe insertar el cierre de la cámara antes que el quickfit.

DE_Der Quickfit-Kopf sollte sich in der Mitte des Cam-Locks befinden, wenn die beiden Platten zusammengefügt sind. Der Cam-Lock sollte vor dem Quickfit eingesetzt werden.

IT_La testa del montaggio rapido deve trovarsi al centro del bloccaggio a camma quando i due pannelli sono uniti. Il Bloccaggio a Camma deve essere inserito prima del montaggio rapido.

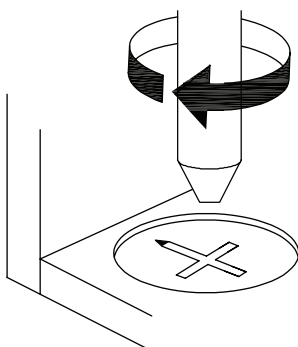

EN_Turn cam lock clockwise to tighten.

FR_Faites tourner la serrure batteuse dans le sens des aiguilles d'une montre pour la resserrer.

ES_Gire el cierre de la cámara en sentido horario para apretarlo.

DE_Drehen Sie den Cam-Lock im Uhrzeigersinn, um ihn festzuziehen.

IT_Ruotare il bloccaggio a camma in senso orario per stringere.

EN It may be necessary to adjust the hinges so that the doors align. Use the instructions below as a guide.

FR Il est parfois nécessaire d'ajuster les charnières pour un meilleur alignement des portes. Servez-vous des instructions ci-dessous comme guide.

ES Puede que sea necesario ajustar los quicios de forma que se alineen las puertas. Use las instrucciones que aparecen debajo como guía.

DE Möglicherweise müssen Sie die Scharniere so einstellen, dass die Türen ausgerichtet sind. Verwenden Sie die nachstehenden Anweisungen als Leitfaden.

IT Potrebbe essere necessario regolare le cerniere in modo che le porte siano allineate. Per fare ciò attenersi alle istruzioni sottostanti.

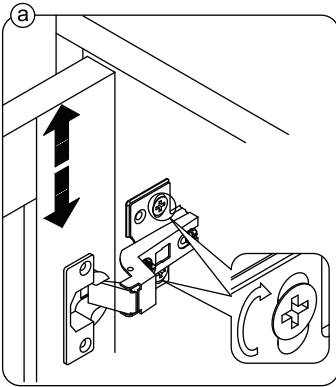

EN To adjust the door vertically loosen the screw as shown and move up and down as needed.

FR Si vous souhaitez régler la porte **verticalement**, desserrez la vis comme indiqué et déplacez la porte de haut en bas selon les besoins.

ES Para ajustar la puerta **verticalmente** afloje el tornillo tal y como se muestra y muévelo hacia arriba o hacia abajo según sea necesario.

DE Um die Tür **vertikal** auszurichten, lösen Sie die Schraube wie abgebildet und bewegen Sie sie nach Bedarf nach oben oder nach unten.

IT Per allineare la porta **verticalmente** allentare la vite come mostrato e spostarla in alto o in basso secondo necessità.

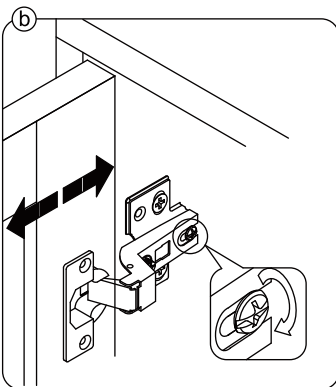

EN To adjust the gap from the door to the main frame turn the screw clockwise or anti-clockwise as needed.

FR Si vous souhaitez ajuster l'**écart** entre la porte et le cadre principal, tournez la vis dans le sens des aiguilles d'une montre ou dans le sens inverse, si nécessaire.

ES Para ajustar el **espacio** desde la puerta al marco principal, gire el tornillo en sentido horario o antihorario, según se necesite.

DE Um den **Abstand** von der Tür zum Hauptrahmen auszurichten, drehen Sie die Schraube je nach Bedarf im oder gegen den Uhrzeigersinn.

IT Per regolare lo **spazio** tra la porta e il telaio principale, avvitare o svitare la vite secondo necessità.

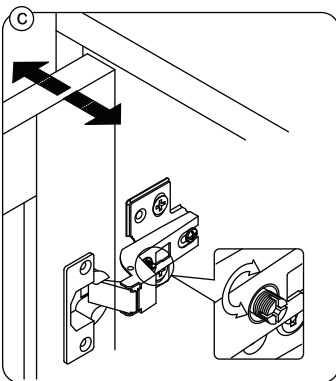

EN To adjust the door laterally adjust the screw as shown by turning clockwise or anti-clockwise.

FR Si vous souhaitez ajuster la porte **latéralement**, ajustez la vis comme indiqué en tournant dans le sens des aiguilles d'une montre ou dans le sens inverse des aiguilles d'une montre.

ES Para ajustar la puerta **lateralmente** ajuste el tornillo tal y como se muestra girándolo en sentido horario y antihorario.

DE Um die Tür **seitlich** auszurichten, stellen Sie bitte die Schraube wie abgebildet durch Drehen im oder gegen den Uhrzeigersinn ein.

IT Per allineare la porta **lateralmente** regolare la vite come mostrato, avvitarandola o svitandola.

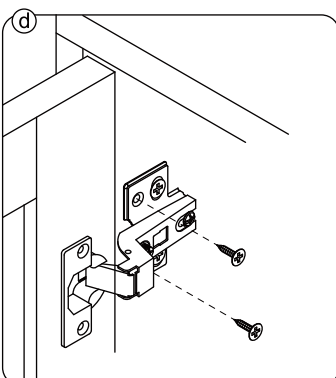

EN Please fix other screws

FR Merci de serrer les autres vis.

ES Fije los demás tornillos

DE Befestigen Sie bitte die anderen Schrauben

IT Fissare le altre viti

BOX-1/2 N625P318149

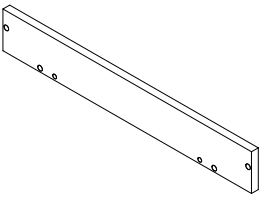
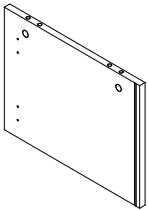
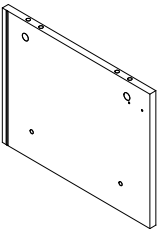
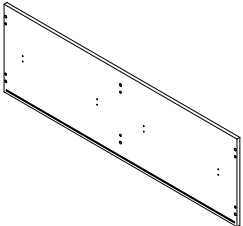
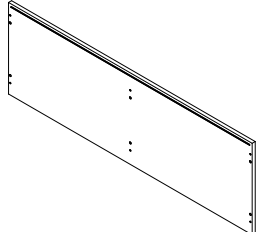
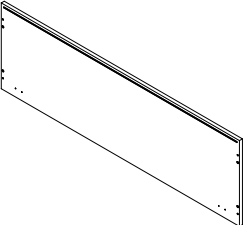
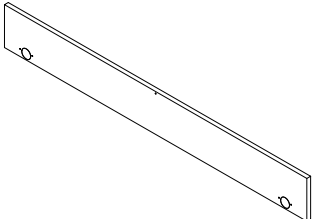
5		1
9		1
10		1
15		1
16		1
17		1
18		1

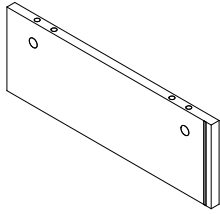
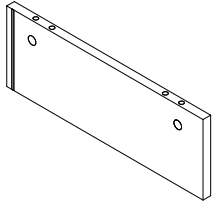
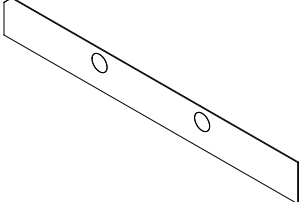
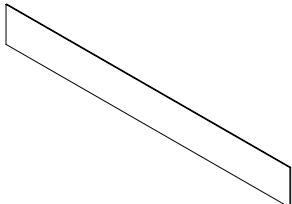
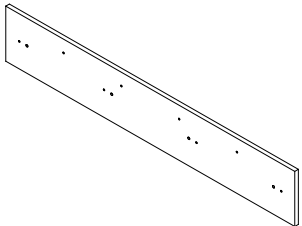
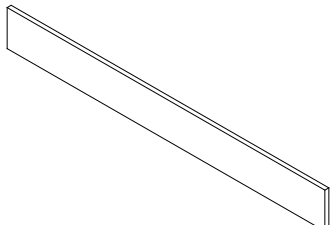
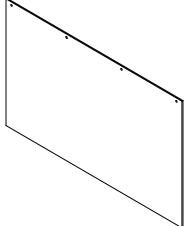



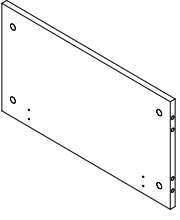
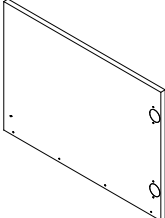
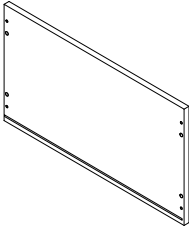
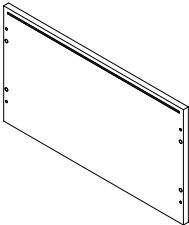
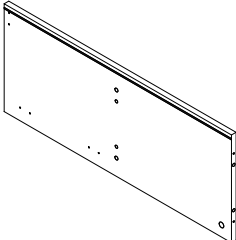
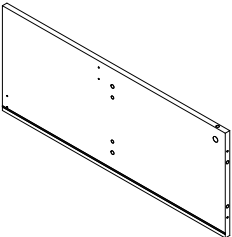
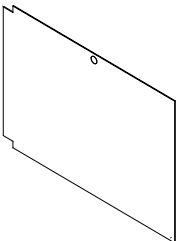
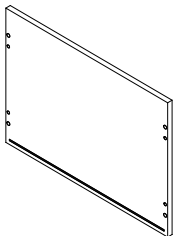

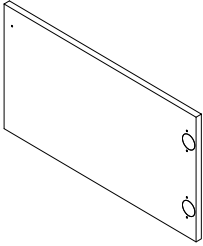
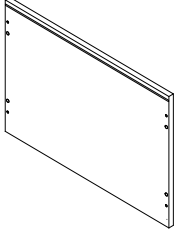
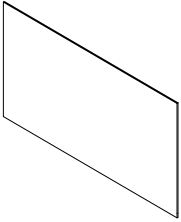
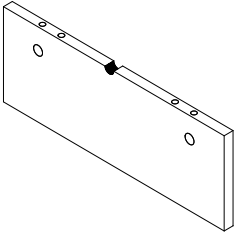
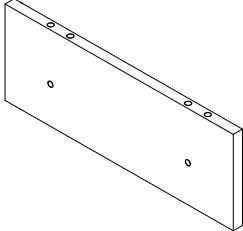
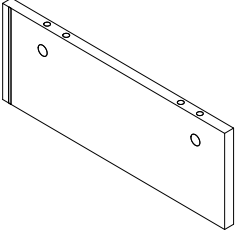
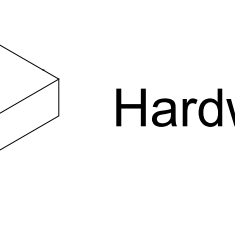
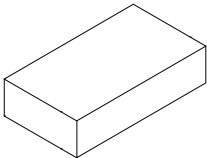



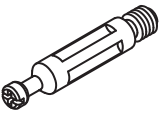

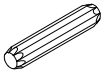
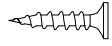
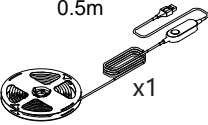
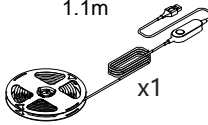
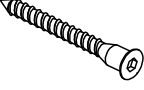
19		1
20		1
24		1
25		1
26		1
27		1
28		1

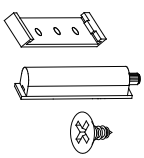
BOX-2/2 N625P318150

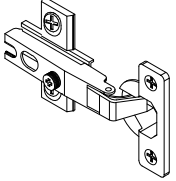
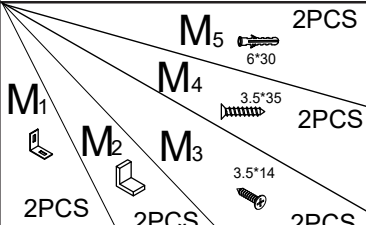
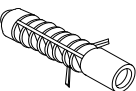
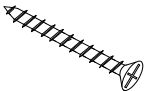
①		1
②		1
③		1
④		1
⑥		1
⑦		1
⑧		1
⑪		1

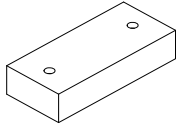
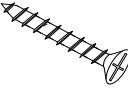
⑫		1
⑬		1
⑭		1
⑳		1
㉑		1
㉒		1
㉓		1
		Hardware kit

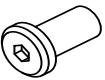
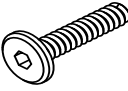
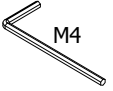

Hardware N625P318150

A  22 PCS	B  22PCS	C 8*40  46PCS	D 3.5*14  72PCS
E 0.5m  x1 1 SET	F 1.1m  x1 1 SET	G 5*40  26 PCS	H  M3 1PC
I  34PCS	J  3SET	K  2PCS	L  6PCS
 M ₁ 2PCS M ₂ 2PCS M ₃ 2PCS M ₄ 3.5*35 2PCS M ₅ 6*30 2PCS 3.5*14 2PCS	N  40*8mm 4PCS	O  50*5mm 4PCS	P  14PCS
Q  4PCS	R  9PCS	S  25*3.5mm 18PCS	T  2PCS
U  30*3.5mm 4PCS	V  2PCS	W  6*20mm 2PCS	X  M4 2PCS
Y  6PCS			

EN: If you find that the white glue particles on the board are missing, please press part K into the board.
 DE: Sollten Sie feststellen, dass die weißen Gummipartikel auf der Platine fehlen, drücken Sie bitte Teil K in die Platine.
 FR: Si vous constatez qu'il manque des particules de caoutchouc blanc sur le tableau, veuillez enfoncer la partie K dans le tableau.
 IT: Se trovi che mancano le particelle di gomma bianca sulla tavola, premi la parte K sulla tavola.
 ES: Si descubre que faltan las partículas de goma blancas en el tablero, presione la parte K en el tablero.

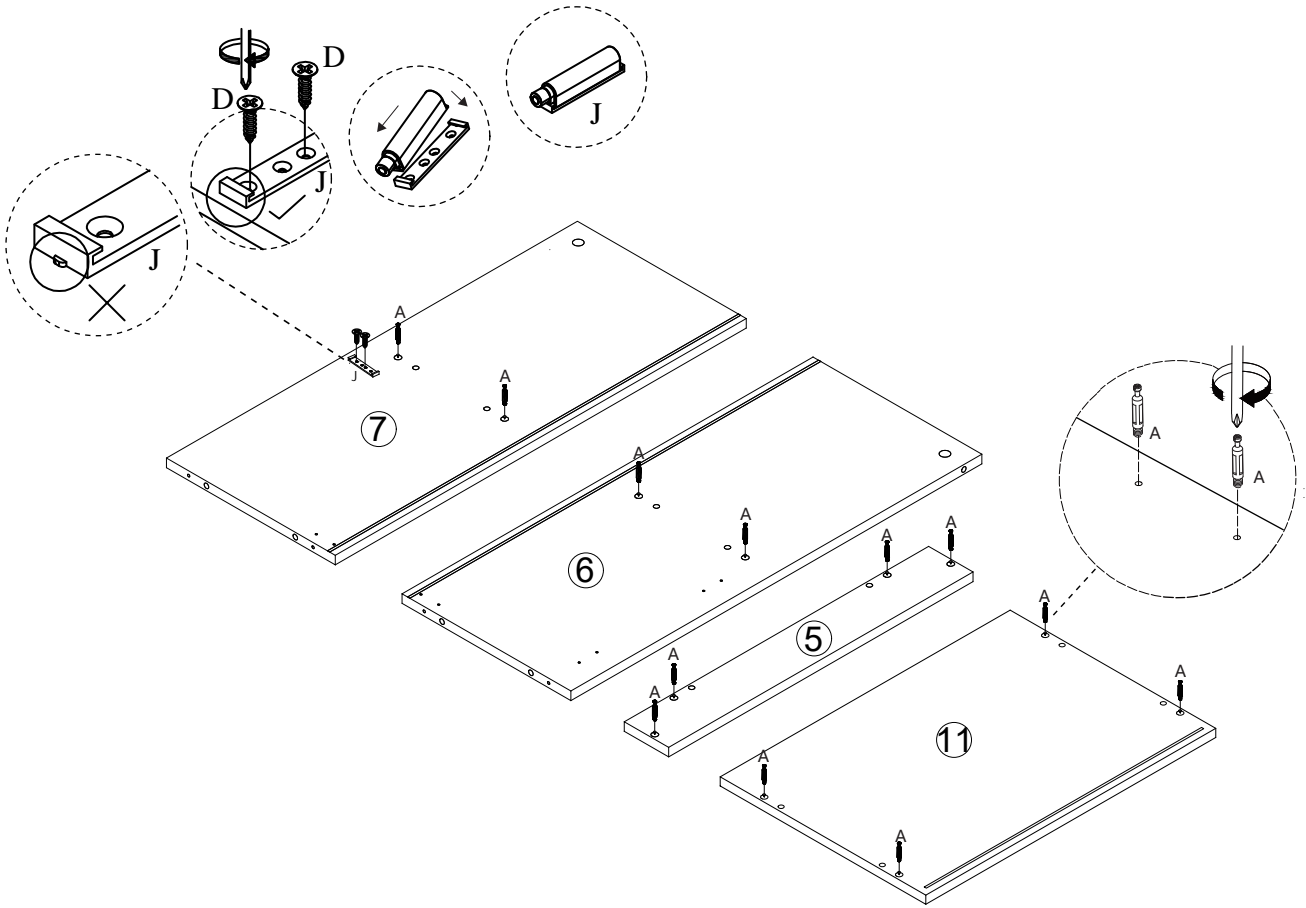

1



<p>A</p>  <p>12PCS</p>	<p>D 3.5*14</p>  <p>2PCS</p>	<p>J</p>  <p>1PC</p>
--	--	--

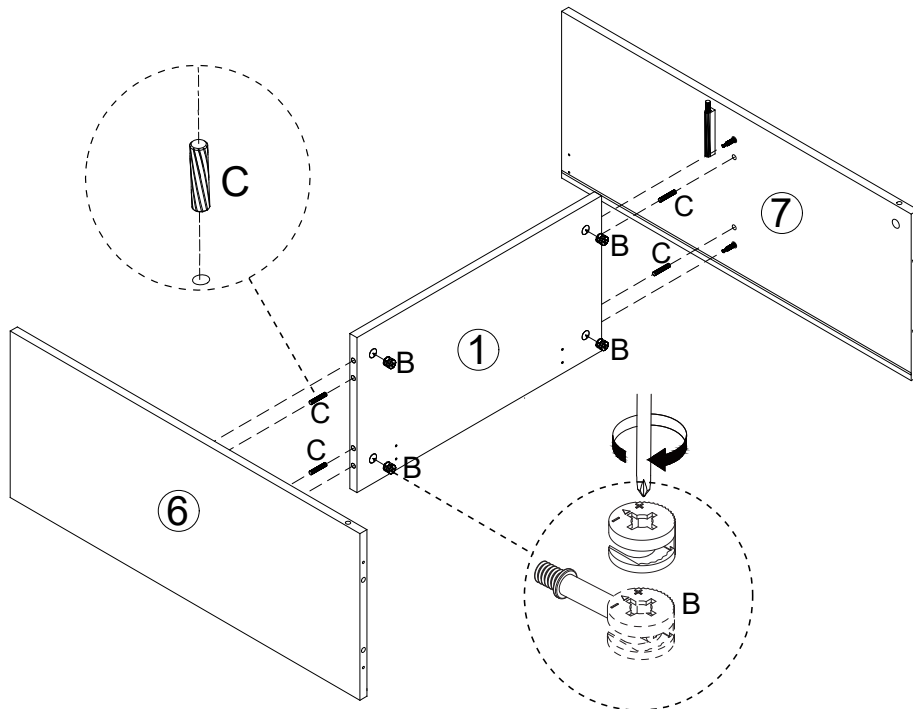

2



<p>B</p>  <p>4PCS</p>	<p>C</p>  <p>4PCS</p>
---	---

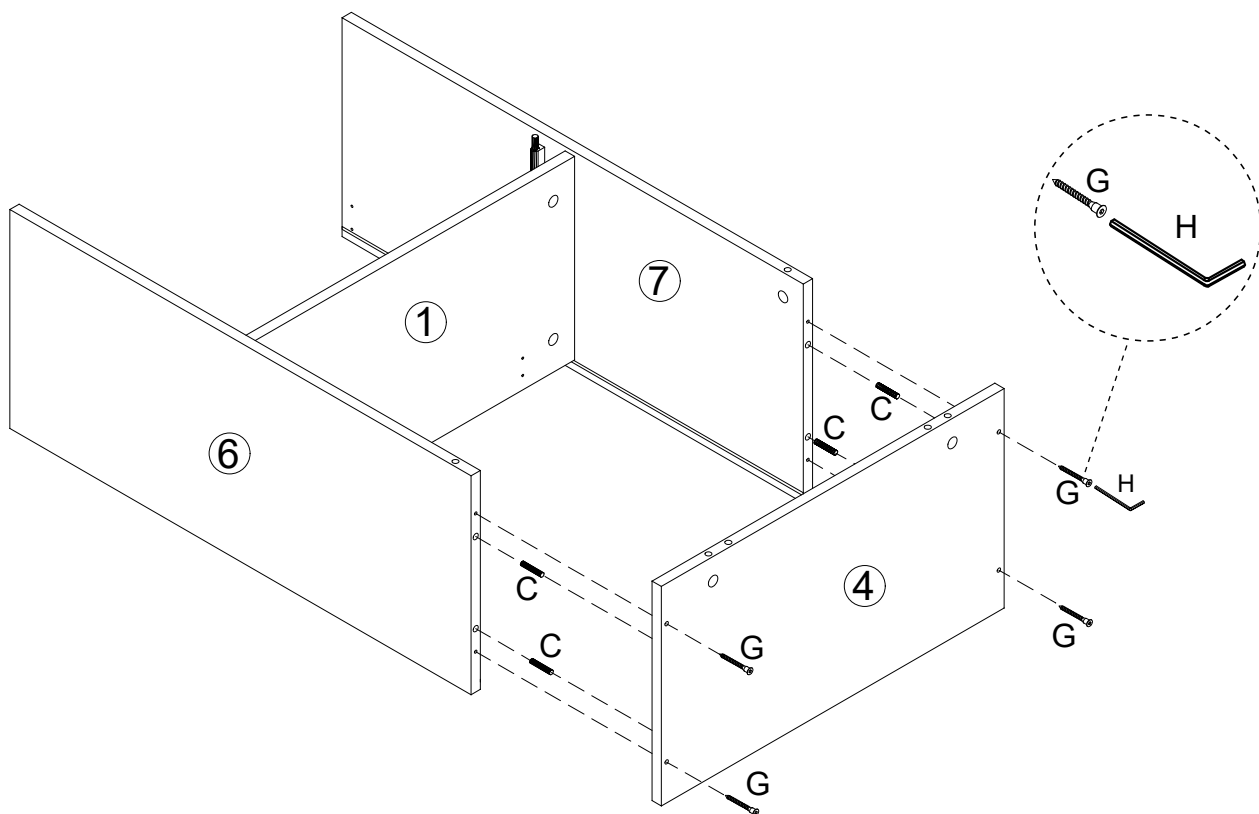

3

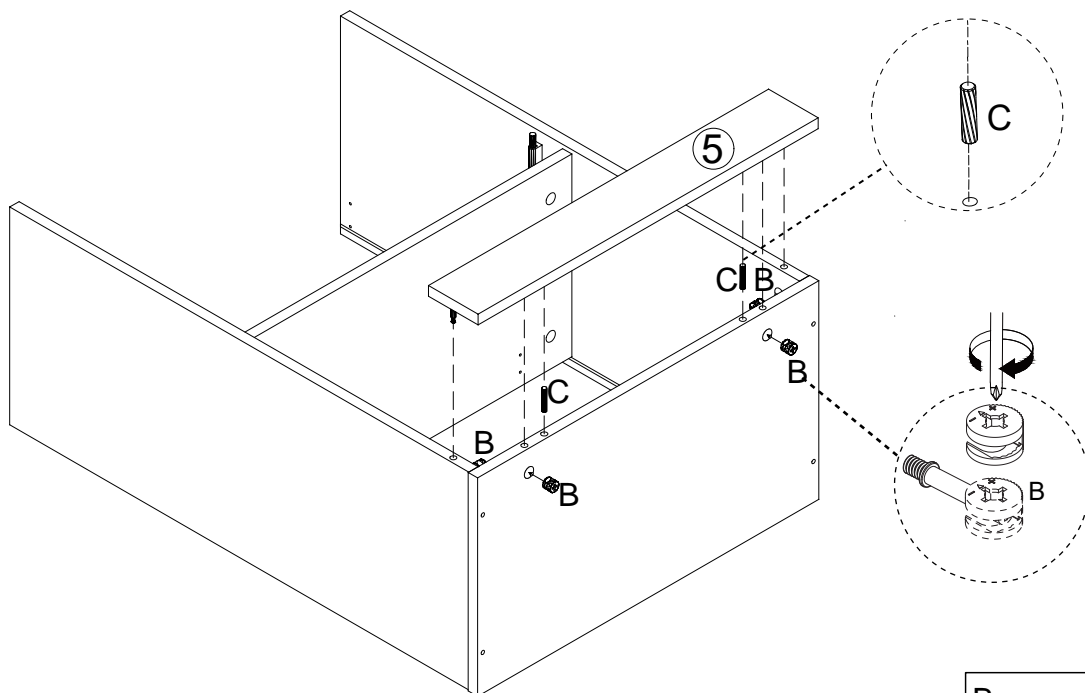

<p>C</p>  <p>4PCS</p>	<p>G 5*40</p>  <p>4PCS</p>	<p>H</p>  <p>1PC</p>
---	--	--

4



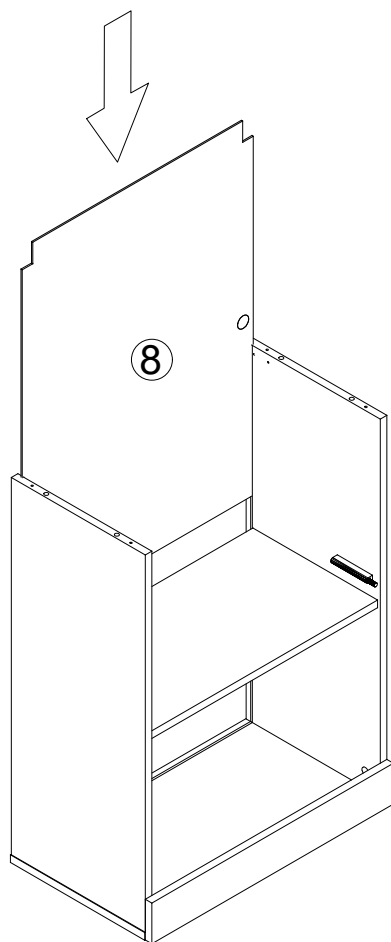

<p>B</p>  <p>4PCS</p>	<p>C</p>  <p>2PCS</p>
---	---

5



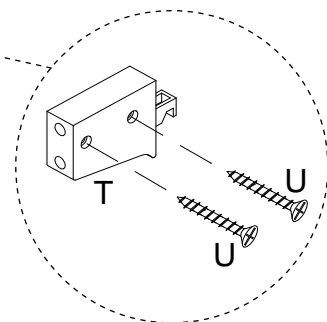
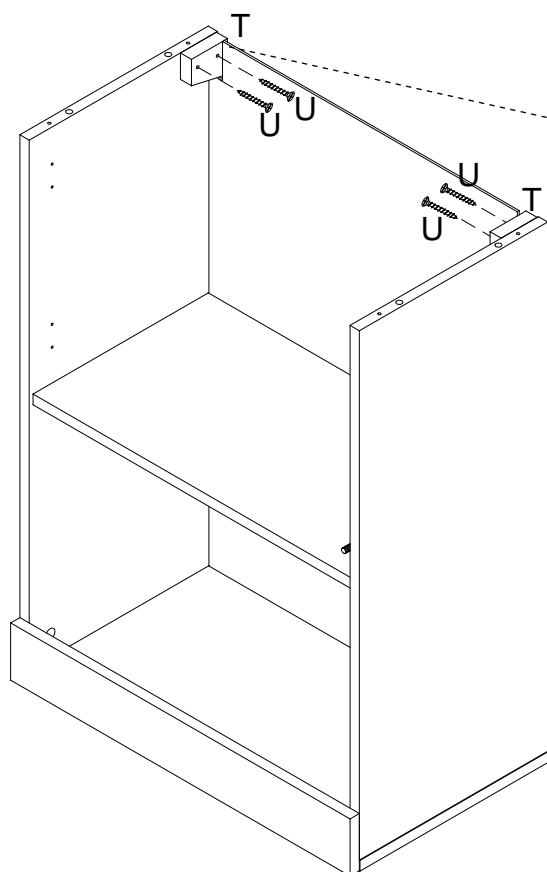

6



<p>T</p>  <p>2PCS</p>	<p>U 30*3.5mm</p>  <p>4PCS</p>
--	---

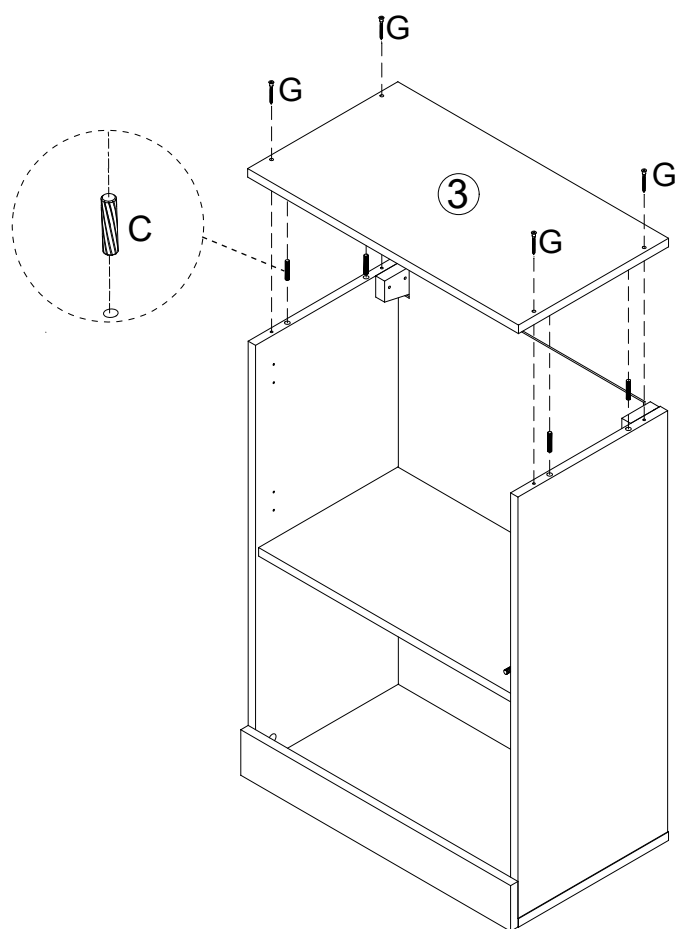



7

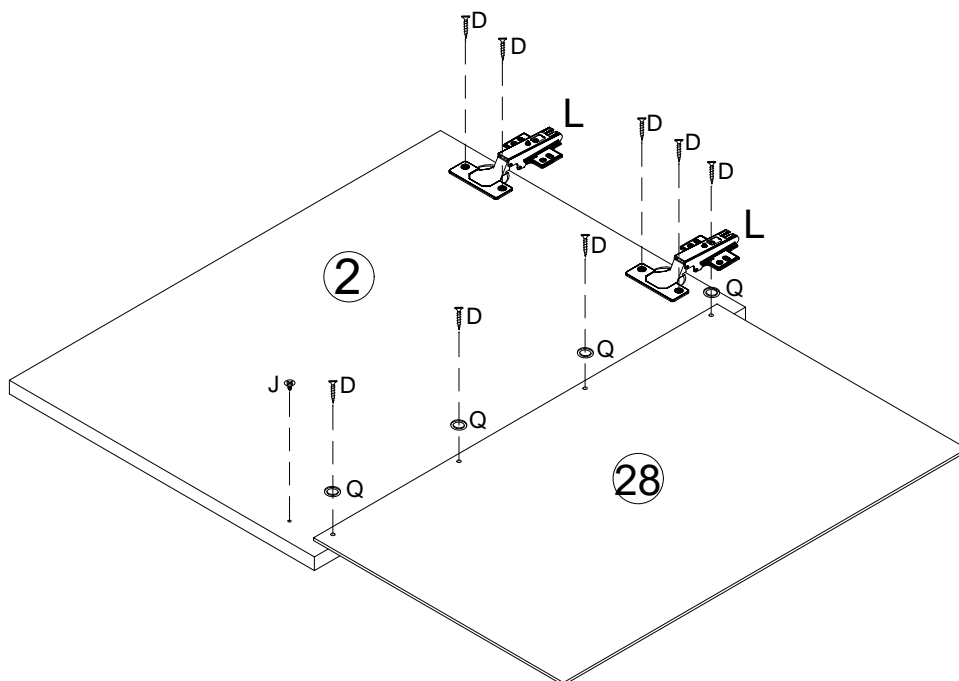

<p>C</p>  <p>4PCS</p>	<p>G 5*40</p>  <p>4PCS</p>
---	--

8



<p>D 3.5*14</p>  <p>8PCS</p>	<p>L</p>  <p>2PCS</p>	<p>Q</p>  <p>4PCS</p>	<p>J</p>  <p>1PC</p>
--	---	---	--

9

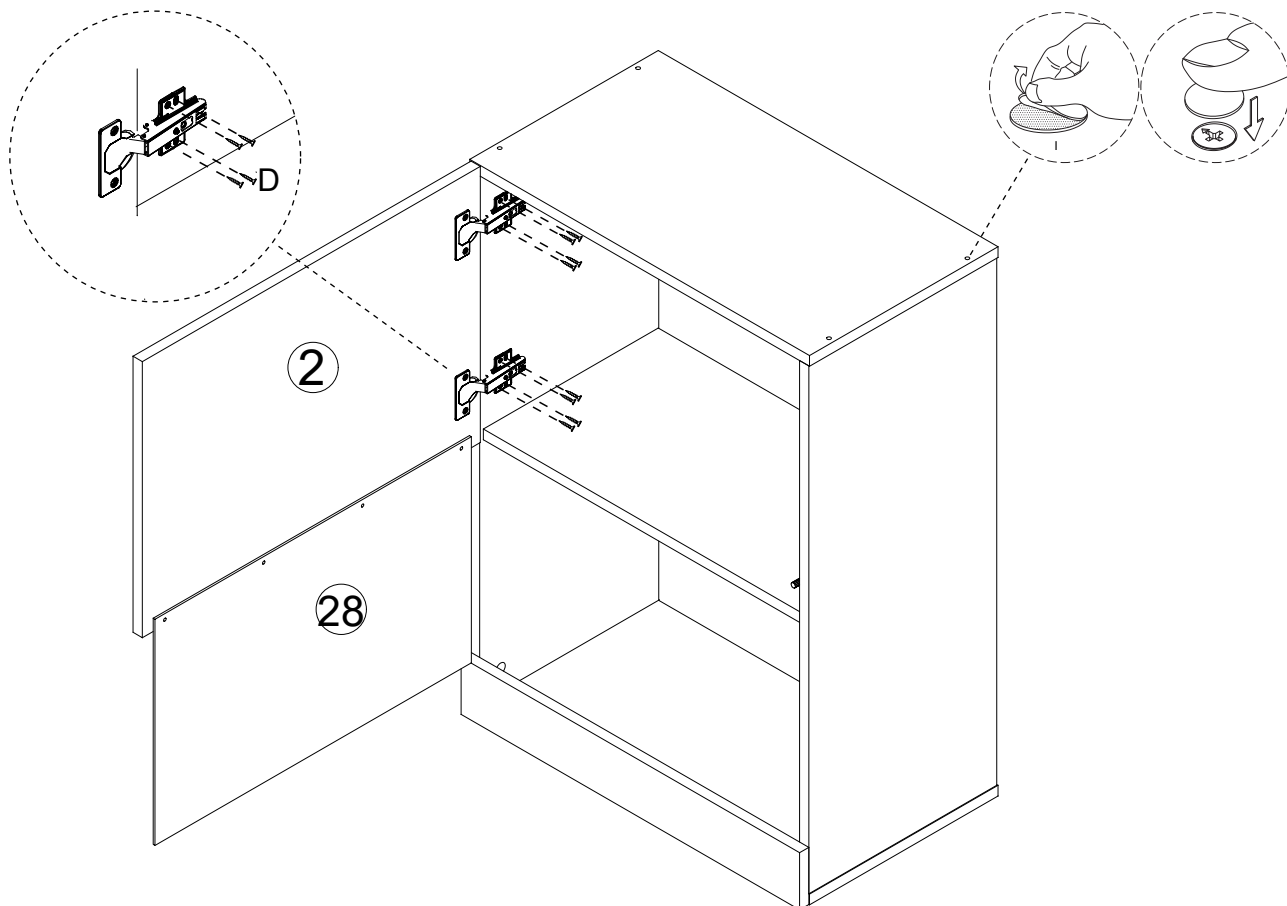

D	I
8PCS	12PCS

10

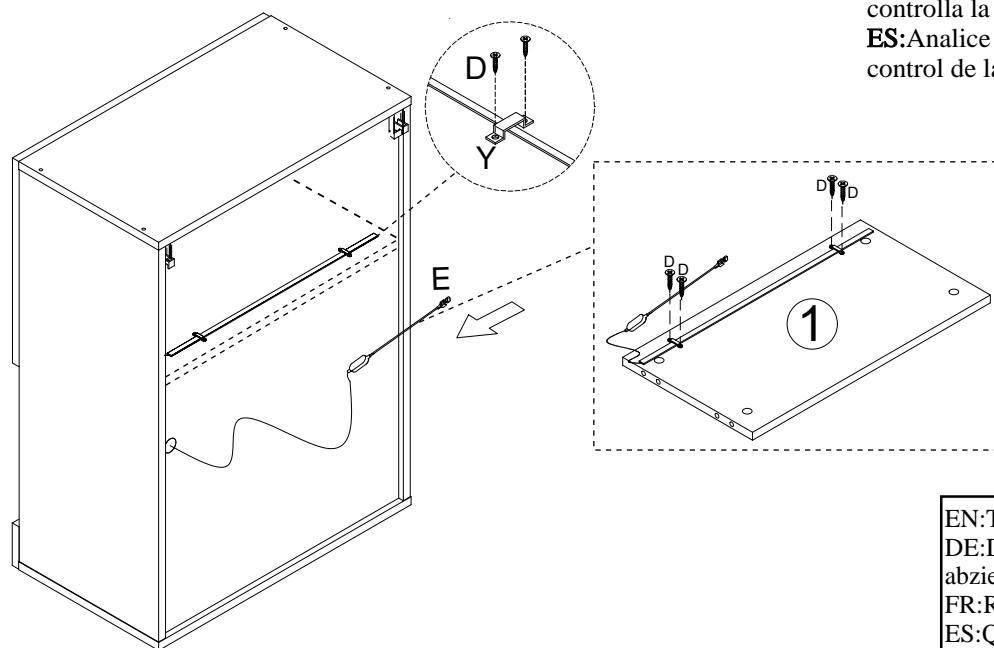

EN: Scan to download App control the Led light.

DE: Das led-display wird durchsucht.

FR: Scanner pour télécharger App contrôler la lumière Led.

IT: Scansiona per scaricare l' applicazione controlla la luce Led.

ES: Analice para descargar la aplicación control de la luz Led.

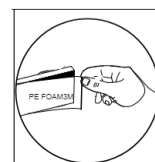

EN: Tear off the back tape
DE: Das Klebeband auf der Rückseite abziehen
FR: Retirez le ruban adhésif arrière
ES: Quitar la cinta trasera
IT: Strappare il nastro posteriore

D	3.5*14	E	Y
4PCS	0.5M x1	1PC	2PCS

11

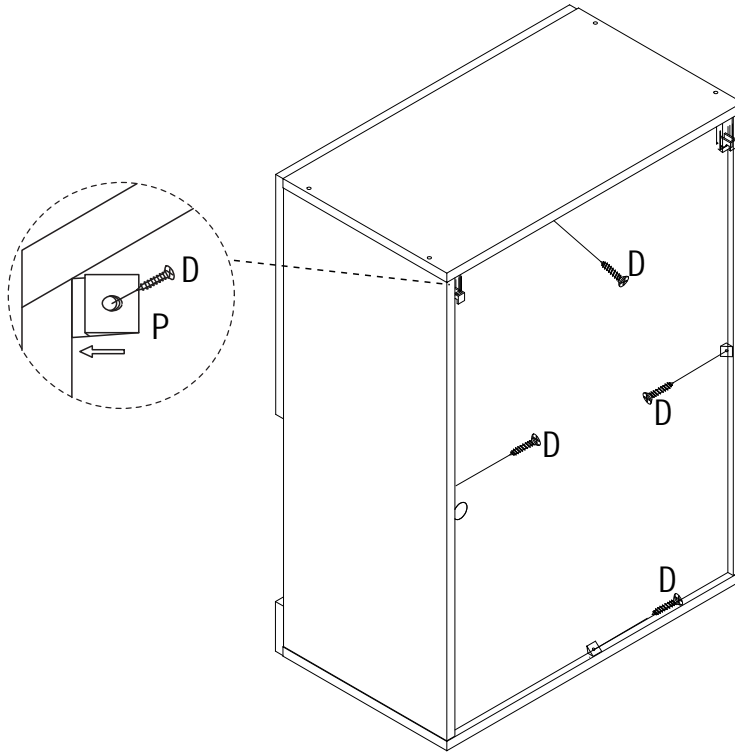

D	3.5*14	P
	4PCS	4PCS

12

DE_ Wenn es sich um eine Massivwand handelt, verwenden Sie bitte Dehnungs- und selbstschneidende Schrauben. Wenn es sich um eine Holzwand handelt, verwenden Sie nur selbstschneidende Schrauben, bitte ziehen Sie die Schrauben nicht zu fest an.

UK_ If it is a solid wal, please use expansion and self-tapping screws, if it is a wooden wall, only use self-tapping screws, please do not overtighten the screws

FR_ Si le mur est massif, veuillez utiliser des chevilles à expansion et des vis autotaraudeuses. mais si s'agit d'un mur en bois, utilisez uniquement des vis autotaraudeuses et ne serrez pas trop les vis.

IT_ Se si tratta di un muro solido, utilizzare sia viti ad espansione che autofilettanti. Se si tratta di un parete in legno, utilizzare solo viti autofilettanti, non stringere eccessivamente le viti.

ES_ Para una pared solida, utilice los tomillos de expansion y autorroscantes. Para una pared demadera, utilice exclusivamente los tornillos autorroscantes, no los apriete demasiado.

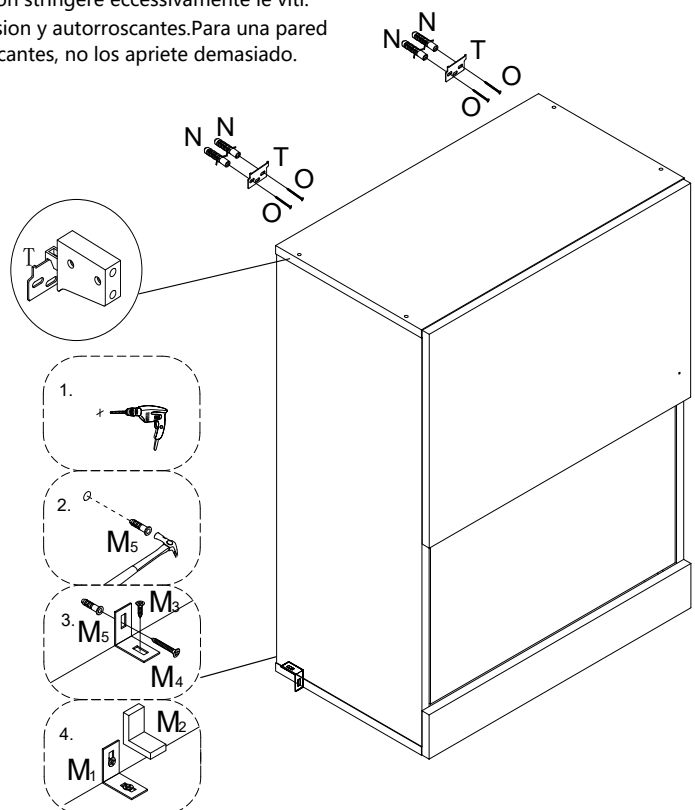

N	O	T
40*8mm	50*5mm	
4PCS	1PC	2PCS

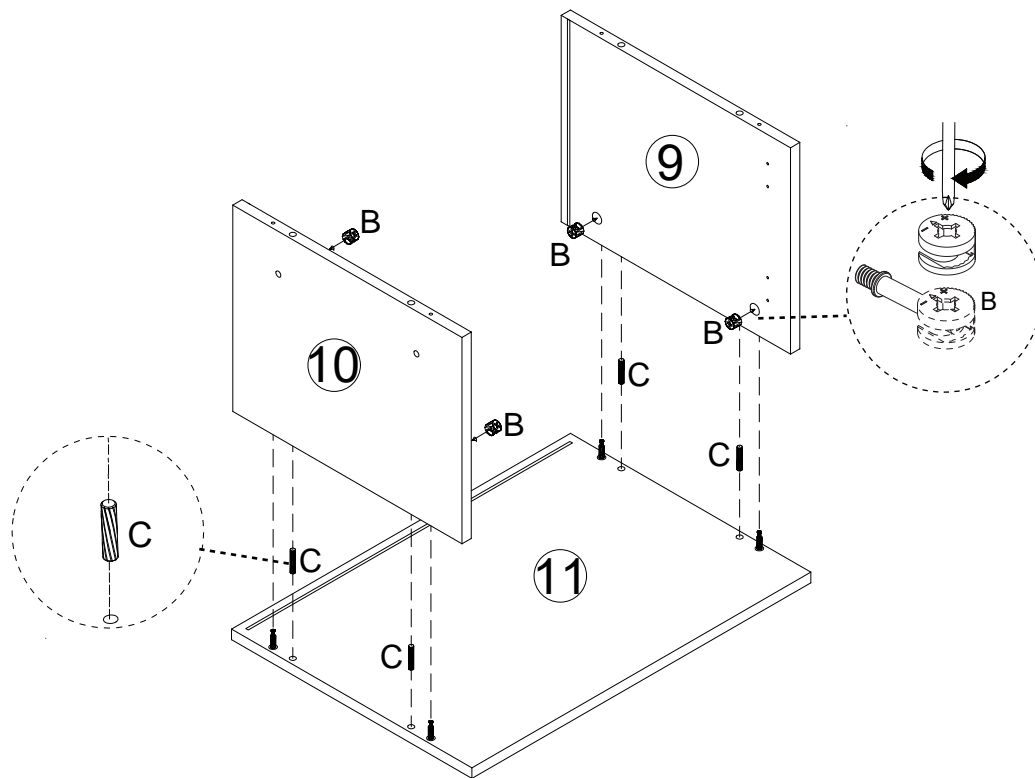

	M ₁ x2pcs
	M ₂ x2pcs
	M ₃ x2pcs
	M ₄ x2pcs
	M ₅ x2pcs

13





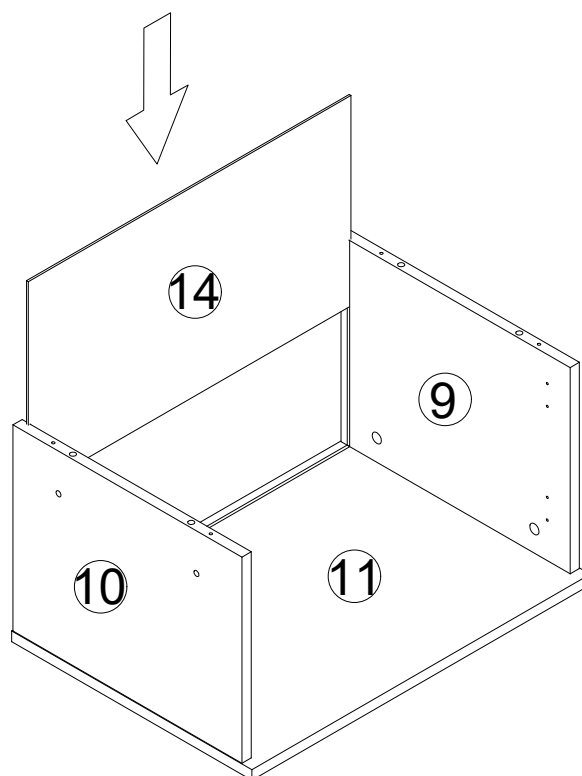

B  4PCS	C  4PCS
---	---

14

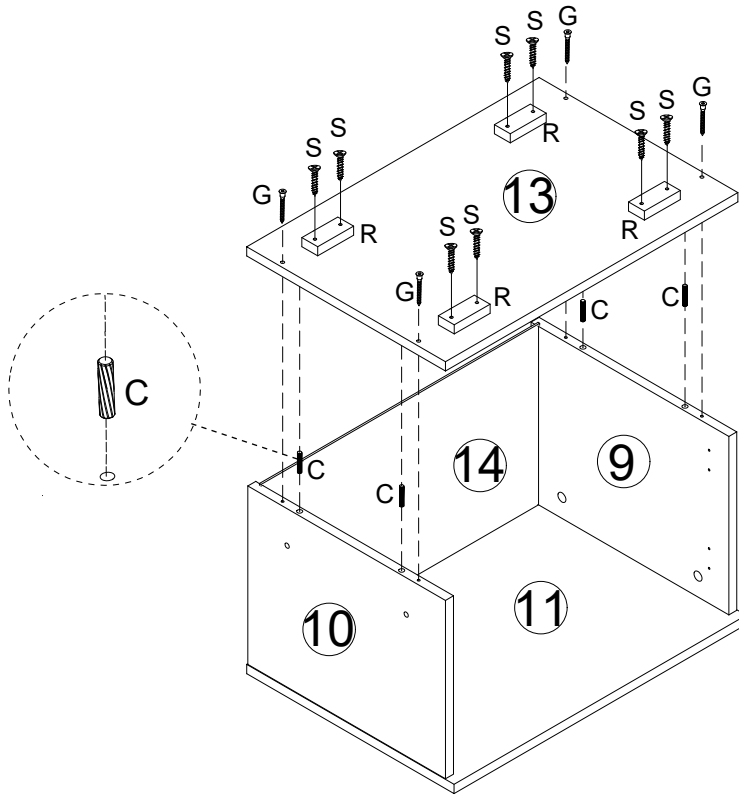



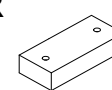

15

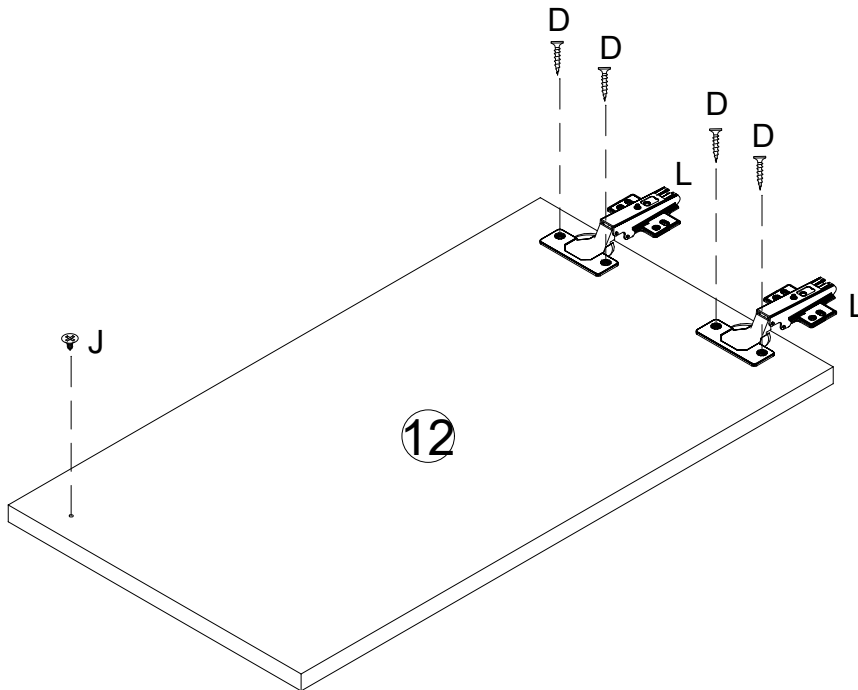

<p>C</p>  <p>4PCS</p>	<p>G 5*40</p>  <p>4PCS</p>	<p>R</p>  <p>4PCS</p>	<p>S 3.5*25</p>  <p>8PCS</p>
---	--	---	--

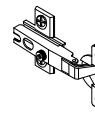

16



<p>D 3.5*14</p>  <p>4PCS</p>	<p>L</p>  <p>2PCS</p>	<p>J</p>  <p>1PC</p>
---	---	--

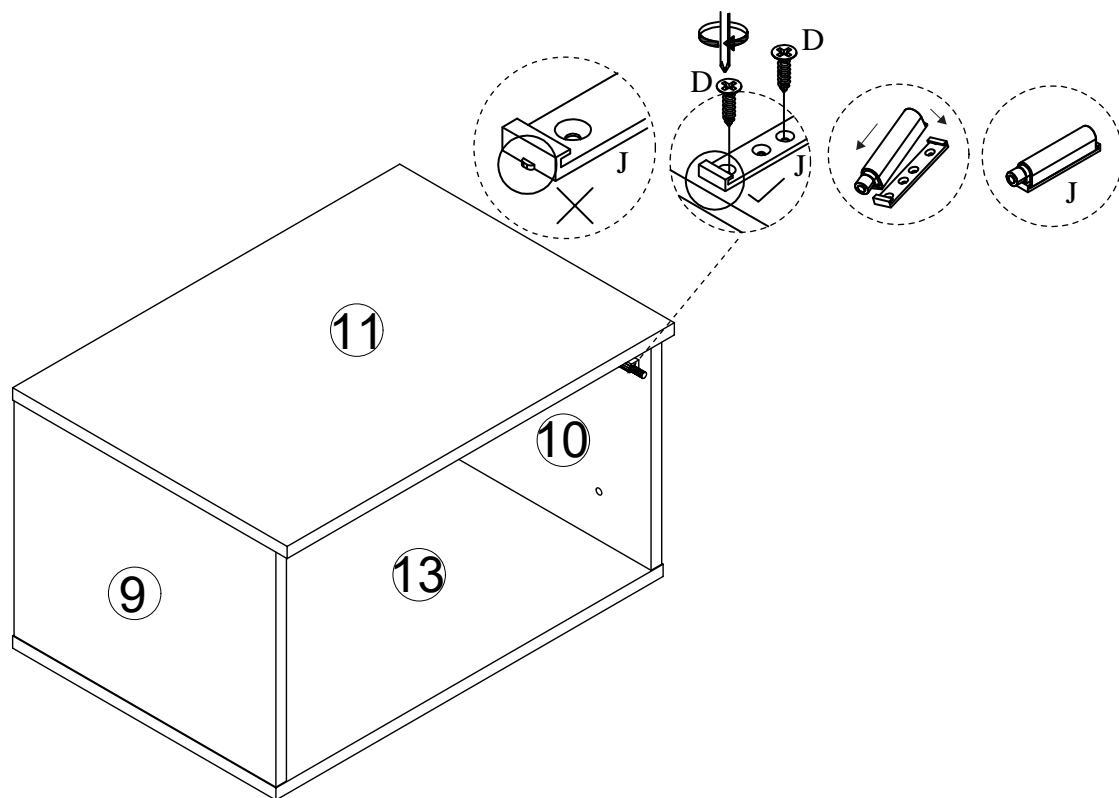

17

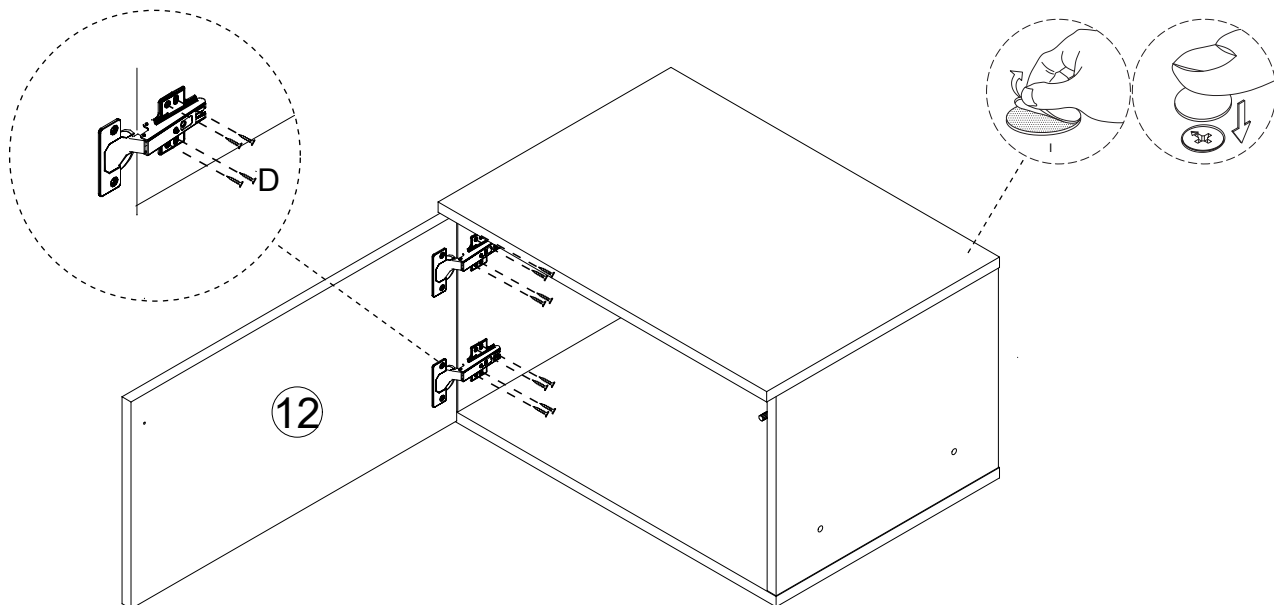

D	3.5*14	J
		
2PCS		1PC

18



D	I
	
8PCS	4PCS

19

EN:Scan to download App control the Led light.
 DE:Das led-display wird durchsucht.
 FR:Scanner pour télécharger App contrôler la lumière Led.
 IT:Scansiona per scaricare l' applicazione controlla la luce Led.
 ES:Analice para descargar la aplicación control de la luz Led.

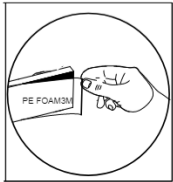
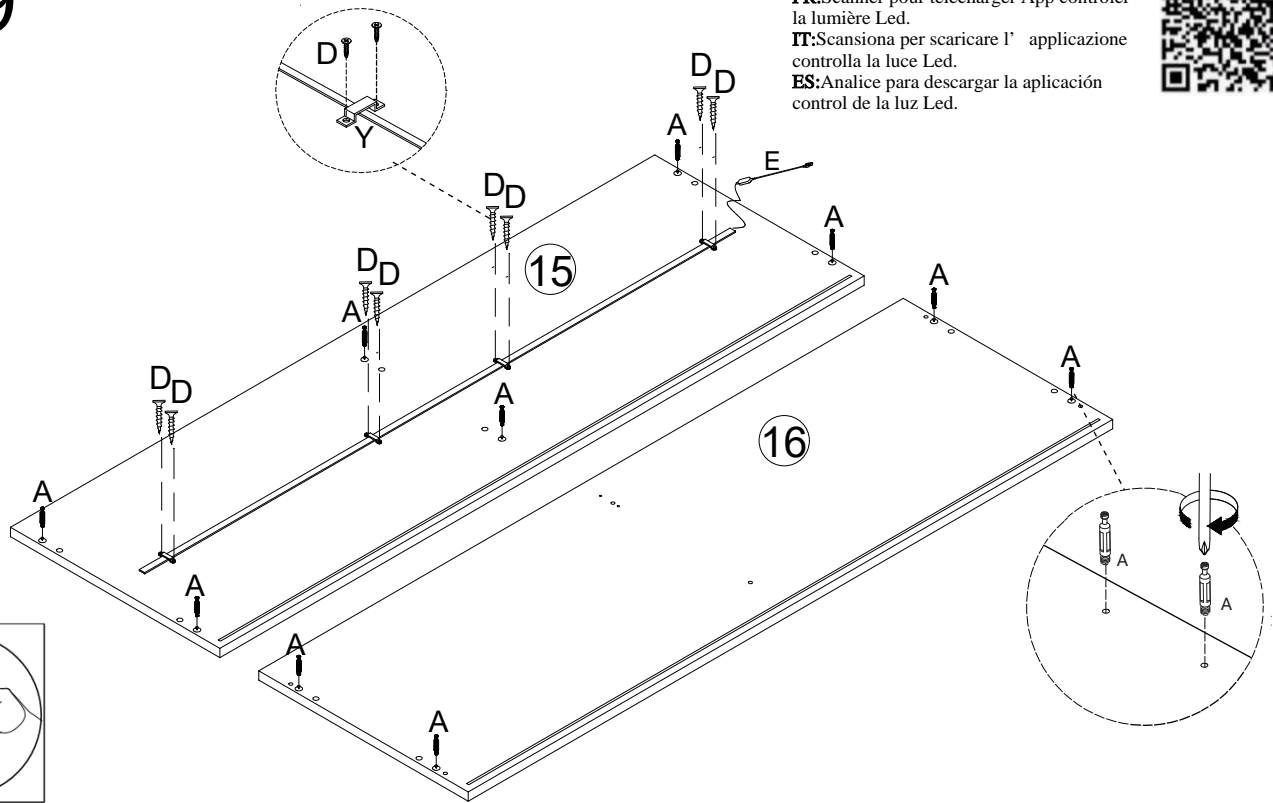

EN:Tear off the back tape
 DE:Das Klebeband auf der Rückseite abziehen
 FR:Retirez le ruban adhésif arrière
 ES:Quitar la cinta trasera
 IT:Strappare il nastro posteriore

A 10PCS	D 3.5*14 8PCS	E 1.1M 1PC	Y 4PCS
-----------------------	-----------------------------	--------------------------	----------------------

20

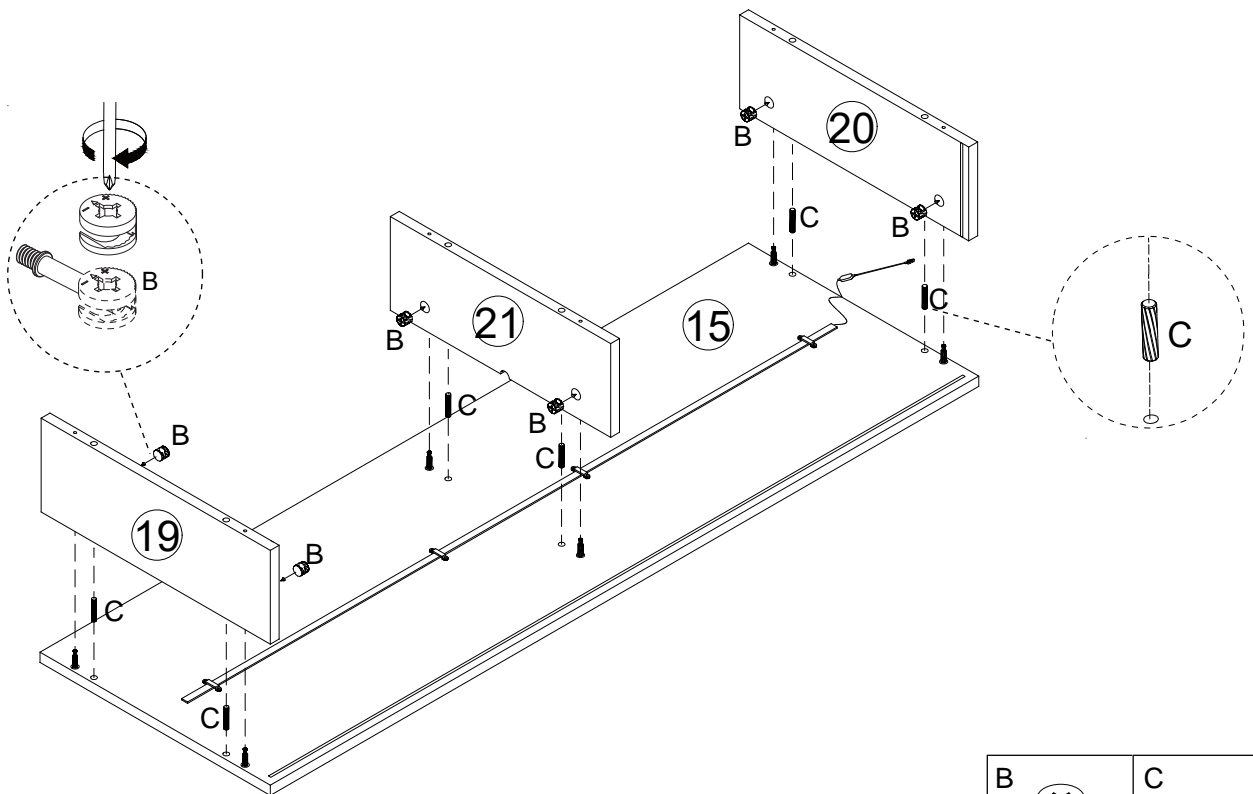

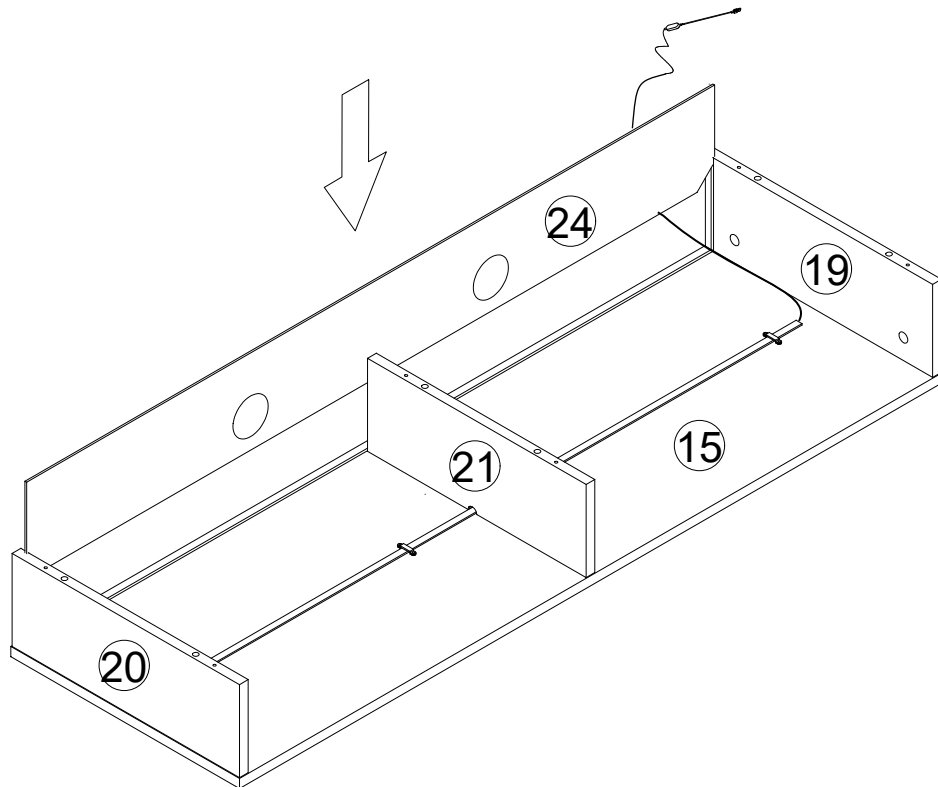

B 6PCS	C 6PCS
----------------------	----------------------

21



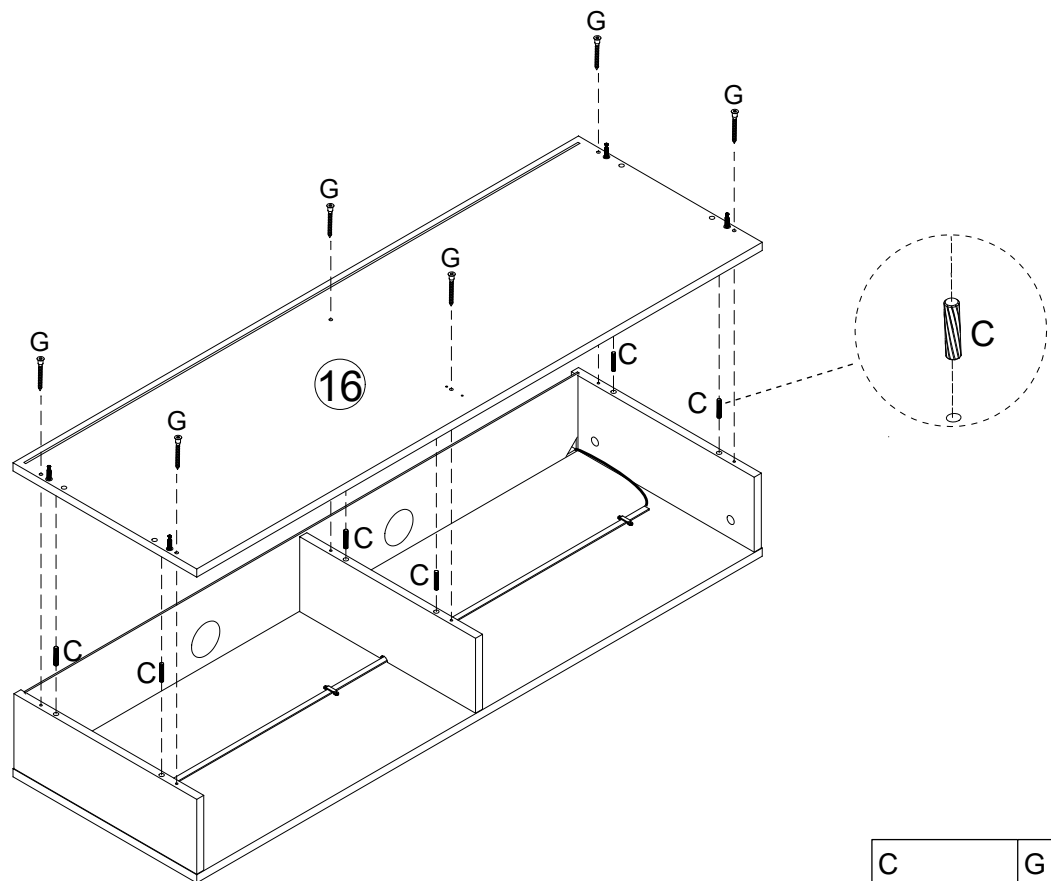

22



C	G	5*40
		
6PCS	6PCS	

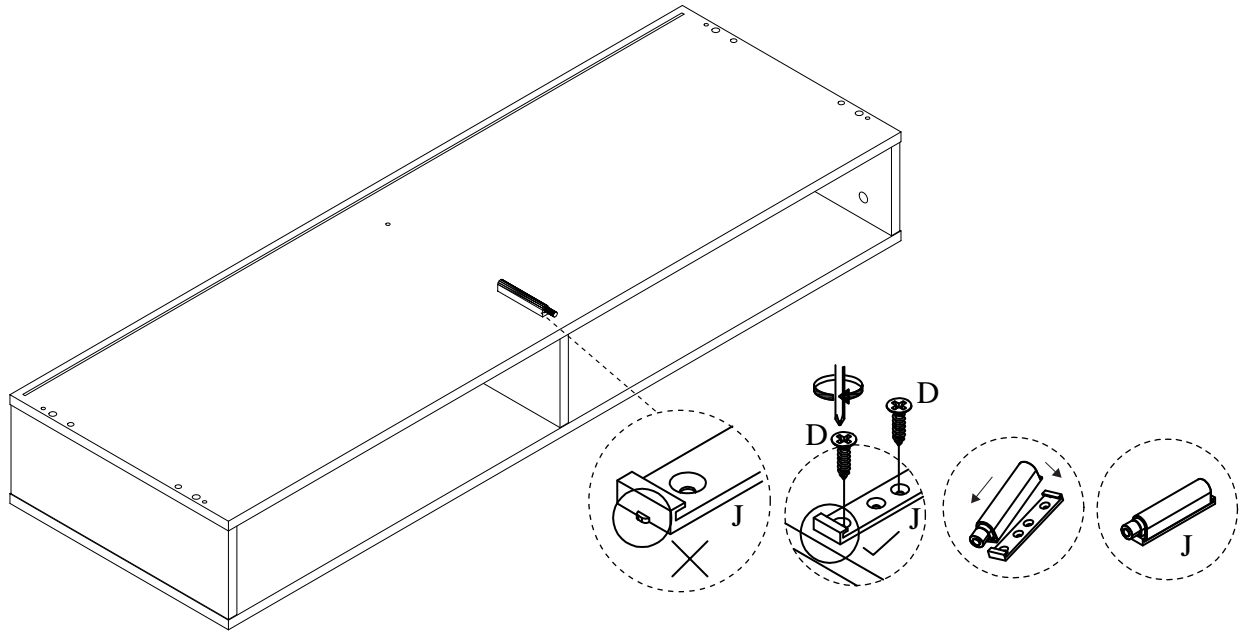

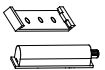

23

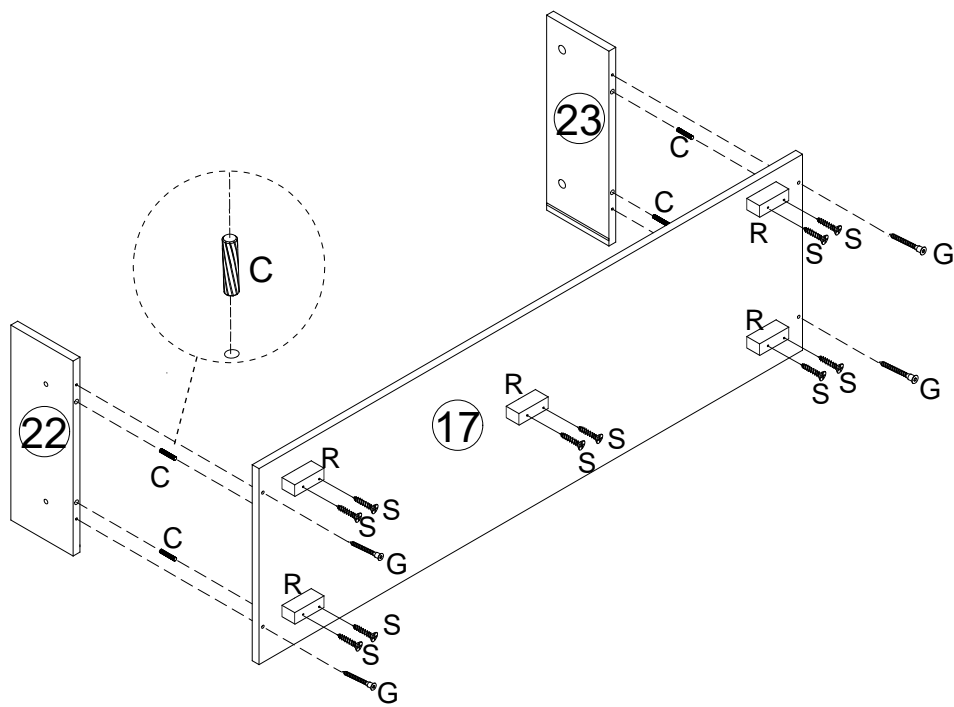

D	3.5*14	J
		
	2PCS	1 PC

24

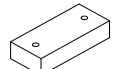



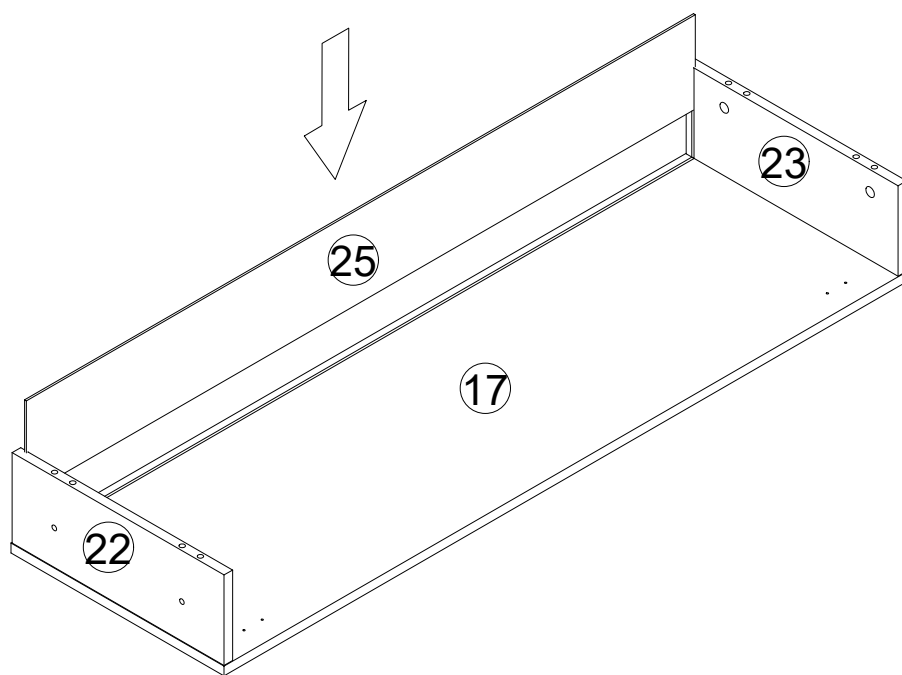

C		G	5*40	R		S	3.5*25
							
4PCS		4PCS		5PCS		10PCS	

25

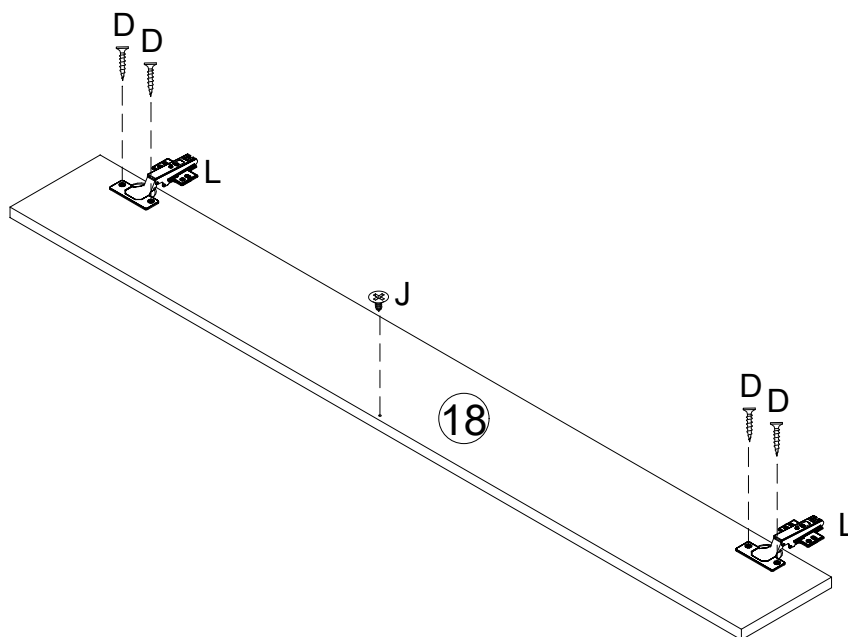

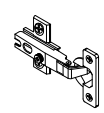

26



D	3.5*14	L	J
			
4PCS		2PCS	1PC

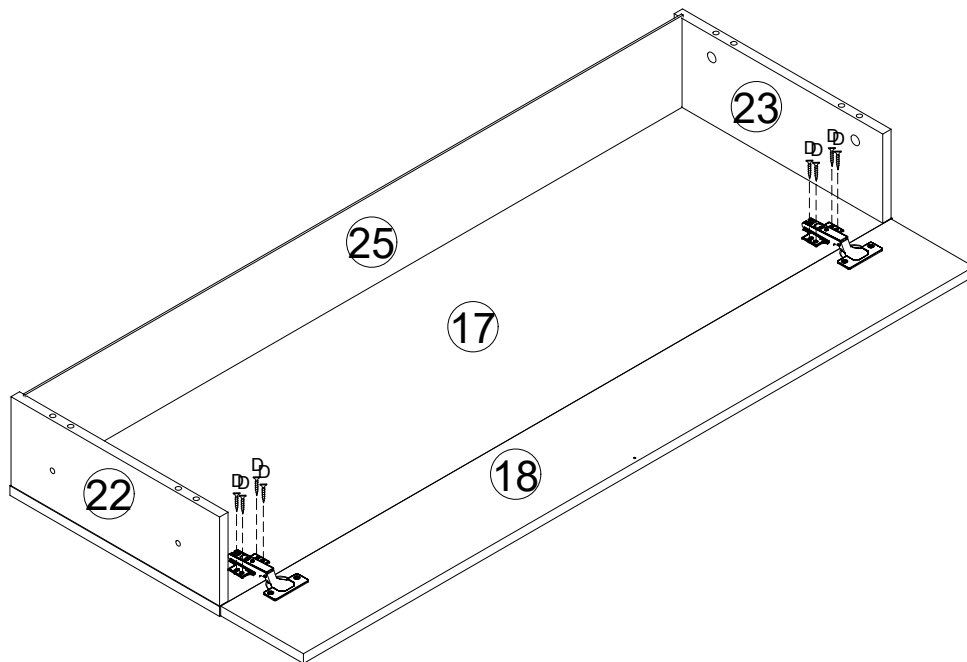

27



D	3.5*14
	
8PCS	

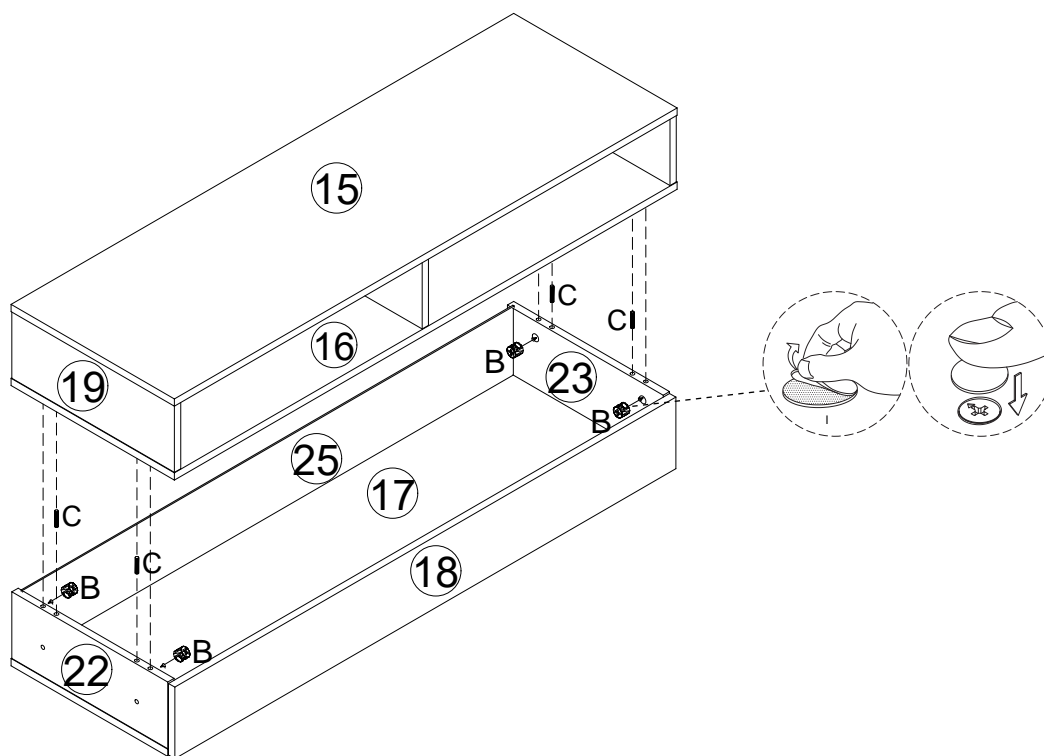

28



B	C	I
		
4PCS	4PCS	10PCS

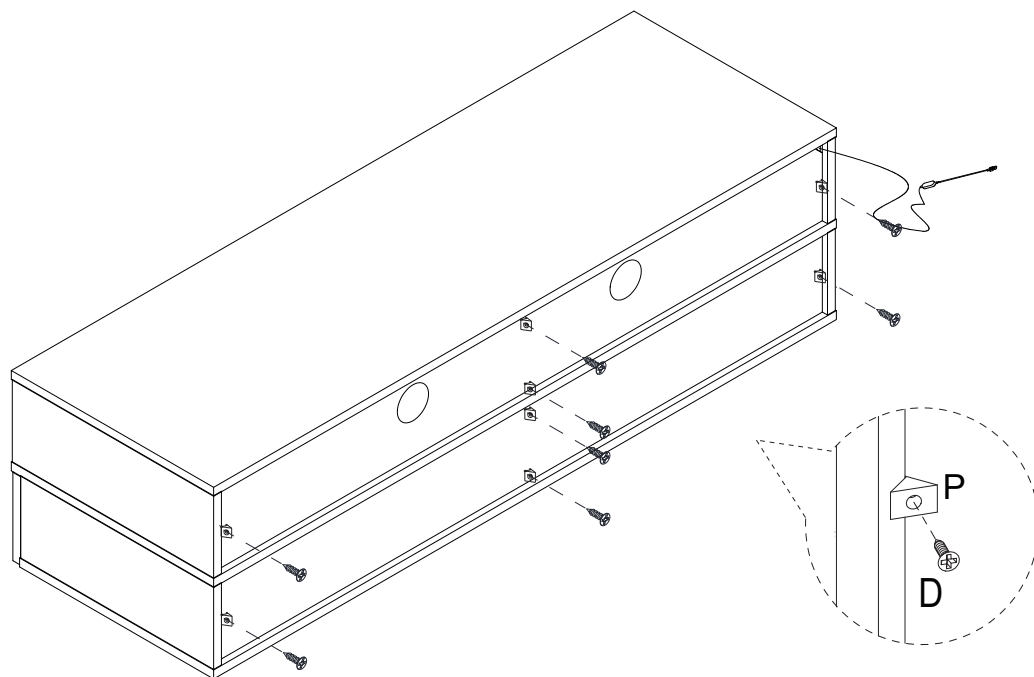

29



D	3.5*14	P
		
8 PCS		8 PCS

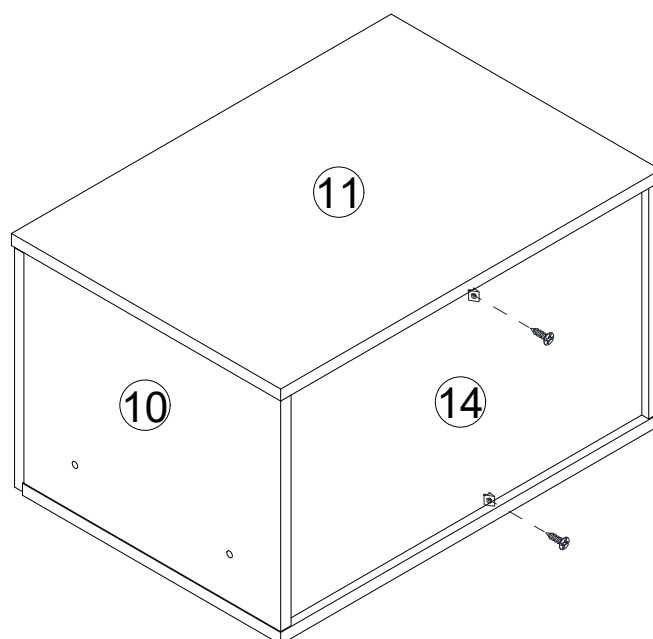



30

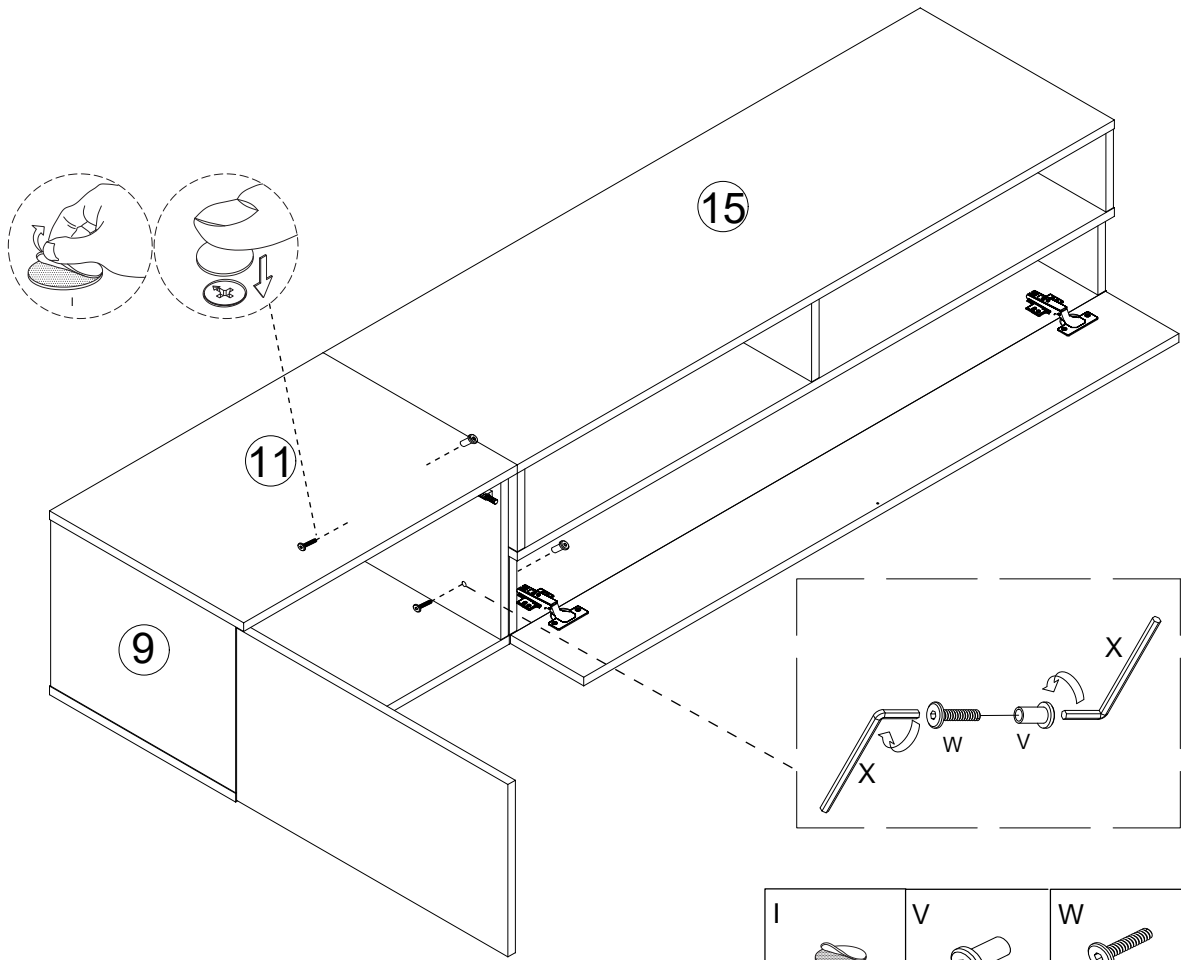

D	3.5*14	P
		
2 PCS		2 PCS



31

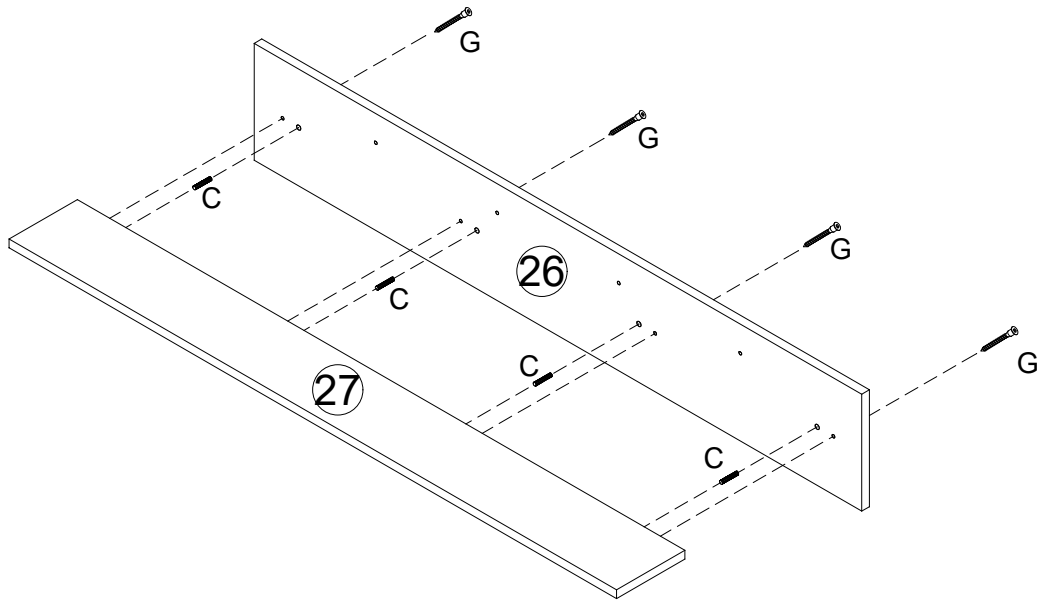

I  4PCS	V  2PCS	W  6*20mm 2PCS	X  M4 2PCS
---	---	---	---

32



C  4PCS	G  5*40 4PCS
---	---

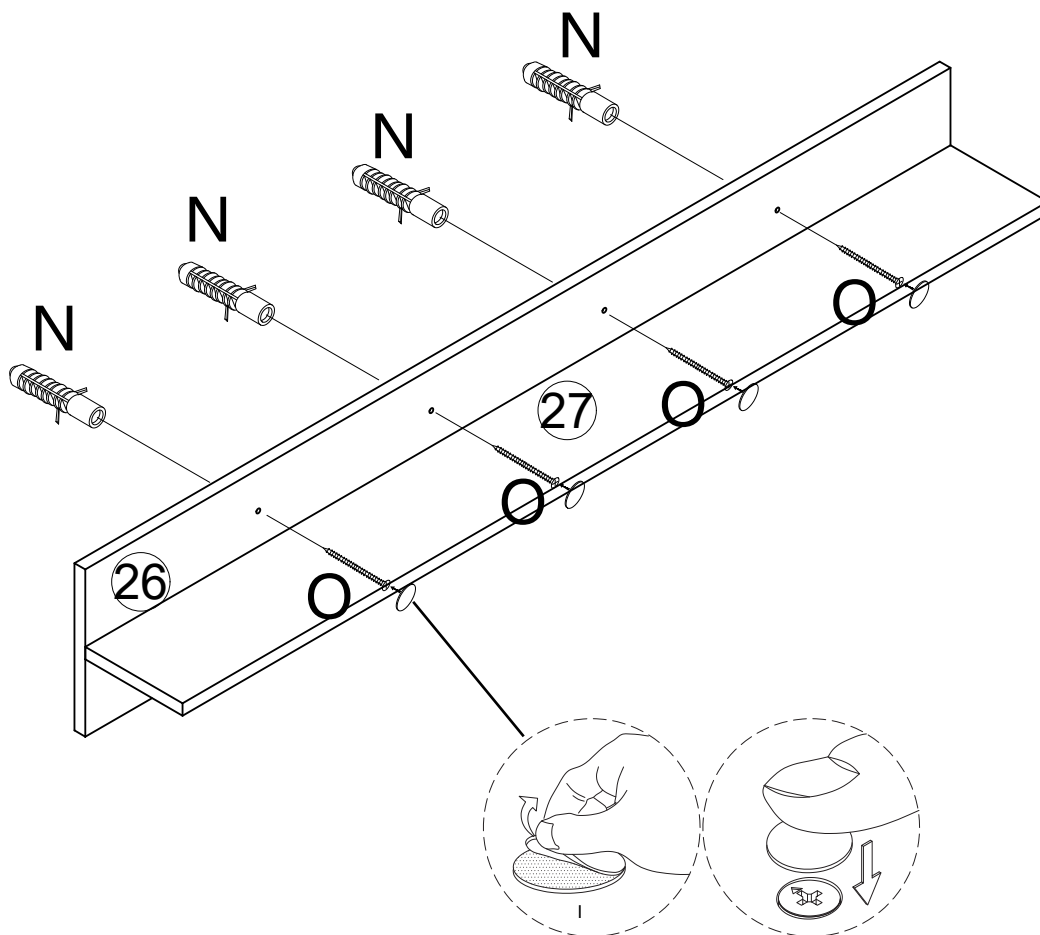



DE_ Wenn es sich um eine Massivwand handelt, verwenden Sie bitte Dehnungs- und selbstschneidende Schrauben. Wenn es sich um eine Holzwand handelt, verwenden Sie nur selbstschneidende Schrauben, bitte ziehen Sie die Schrauben nicht zu fest an.

UK_ If it is a solid wall, please use expansion and self-tapping screws, if it is a wooden wall, only use self-tapping screws, please do not overtighten the screws

FR_ Si le mur est massif, veuillez utiliser des chevilles à expansion et des vis autotaraudeuses. mais si s'agit d'un mur en bois, utilisez uniquement des vis autotaraudeuses et ne serrez pas trop les vis.

IT_ Se si tratta di un muro solido, utilizzare sia viti ad espansione che autofilettanti. Se si tratta di un parete in legno, utilizzare solo viti autofilettanti, non stringere eccessivamente le viti.

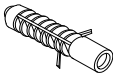
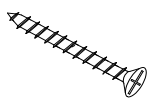
ES_ Para una pared sólida, utilice los tomillos de expansión y autorroscantes. Para una pared de madera, utilice exclusivamente los tornillos autorroscantes, no los apriete demasiado.

<p>N</p>  <p>40*8mm</p> <p>4PCS</p>	<p>O</p> <p>50*5mm</p>  <p>4PCS</p>	<p>I</p>  <p>4PCS</p>
---	--	--

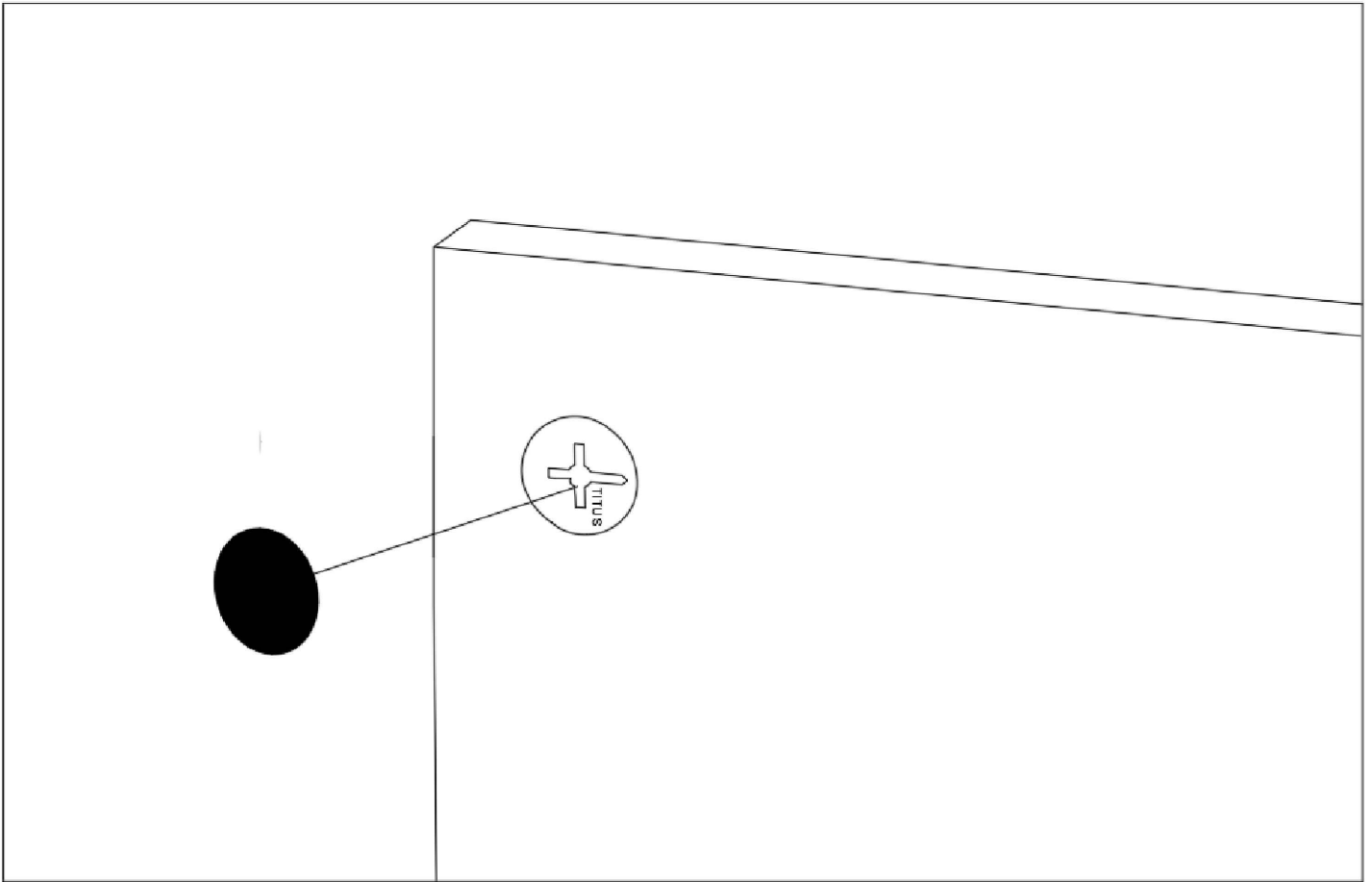

EN:In order to make the product more beautiful, please paste hardware I on the exposed holes.

DE:Um ein präzises produkt ästhetisieren zu können, fügen sie hardware I in eine entblöbte öffnung ein

FR:Afin de rendre le produit plus beau, s' il vous plaît coller le matériel I sur les trous exposés.

IT:Per rendere il prodotto più bello, incollare l' hardware I sui fori esposti.

ES:Con el fin de hacer el producto más hermoso, por favor pega hardware I en los agujeros expuestos



[DE]

BITTE BEACHTEN: Teilenummer 2.5.11.12.15.18 ist mit einer dichten Kunststoffschutzfolie überzogen.

Wenn das Produkt nach der Demontage Kratzer aufweist, machen Sie sich bitte keine Sorgen, es handelt sich nicht um einen Produktschaden.

Bitte ziehen Sie die schützende Kunststoffolie langsam entlang der Kante von der Oberfläche ab. Nach dem Abziehen wird das Produkt glatt und sauber.

[EN]

PLEASE NOTE: Part number 2.5.11.12.15.18 are covered with a tight plastic protective film.

If there are scratches on the product after disassembly, please don't worry, it's not product damage.

Please slowly tear off the protective plastic film on the surface along the edge. After peeling off, the product becomes smooth and clean.

[FR]

REMARQUE : les pièces numéro 2.5.11.12.15.18 sont recouvertes d'

un film protecteur en plastique étanche. Si le produit présente des rayures après le démontage, ne vous inquiétez pas, il ne s'agit pas d'un dommage au produit.

Retirez lentement le film protecteur en plastique sur la surface le long du bord. Une fois décollé, le produit devient lisse et propre.

[IT]

NOTA BENE: il numero di parte 2.5.11.12.15.18

è coperto da una pellicola protettiva in plastica stretta.

Se ci sono graffi sul prodotto dopo lo smontaggio, non preoccuparti, non è un danno al prodotto.

Strappare lentamente la pellicola protettiva in plastica sulla superficie lungo il bordo. Dopo averla staccata, il prodotto diventa liscio e pulito.

[ES]

NOTA: La pieza número 2.5.11.12.15.18

está cubierta con una película protectora de plástico.

Si hay rayones en el producto después de desmontarlo, no se preocupe, no se trata de daños en el producto. Retire lentamente la película protectora de plástico de la superficie a lo largo del borde.

Después de despegarla, el producto quedará liso y limpio.

Verification of Compliance

Verification No.: TMC210319126-E
Name and address of Applicant: **Shenzhen CWG Technology Co., Ltd**
 5 / F, No.264 Baoshi East Road, Shiyan street, Bao'an District, Shenzhen, China 518108
Name and address of Manufacturer: **Shenzhen CWG Technology Co., Ltd**
 5 / F, No.264 Baoshi East Road, Shiyan street, Bao'an District, Shenzhen, China 518108
Product name: **LED Strip**
Rated: DC12V
Product model(s): CWG-5050RGB-60D-12V , additional models reference attachment
Product trademark: 创唯光

This verification confirms that the product meets the requirements of the following standard. The conformity was demonstrated based on following standard(s) listed by European Commission as harmonized with EMC Directive 2014/30/EU.

EN IEC 55015:2019+A11:2020
 IEC 61547:2020

The verification has been carried out in accordance with individual rules and conditions agreed with the applicant. Evaluation has been carried out in accordance with:

Test report(s) No.: TMC210319126-E
Test conducted by: TMC Testing Services (Shenzhen) Co., Ltd.
Verification issue date: March 26, 2021

Notes:

This verification refers to the above mentioned product and its conformity in regards of above mentioned standard(s) was proven on test sample.

This verification does not imply meeting all essential requirements, assessment of the series-production or any other restricted Notified Bodies conformity assessment procedure appropriate for the product.

This verification holder shall use this verification in connection to verification of conformity and technical data relevant for the product the verification was issued.

TMC Testing Services (Shenzhen) Co., Ltd.

t:86-755-86642861 cert@tmc-lab.com www.tmc-lab.com
 1st Floor, Block A1, Zone A, Xinshidai Gongrong Industrial Park, No. 2, Shihuan Road, Shiyan Street, Baoan District, Shenzhen, China



Verification of Compliance

CWG-5050RGB-30D-12V, CWG-5050RGB-18D-12V, CWG-5050RGB-60D-24V,
CWG-5050RGB-60D-5V, CWG-5050RGB-30D-5V, CWG-5050RGB-18D-5V,
CWG-5050-60D-12V, CWG-5050-30D-12V, CWG-5050-60D-24V,
CWG-HC5050RGB-60D-12V, CWG-HC5050RGB-30D-12V,
CWG-HC5050RGB-60D-24V, CWG-HC5050-60D-12V, CWG-HC5050-30D-12V,
CWG-HC5050-60D-24V, CWG-HC5050RGB-30D-5V, CWG-HC5050RGB-60D-5V,
CWG-HC5050RGB-144D-5V, CWG-2835-60D-12V, CWG-2835-120D-12V,
CWG-2835-60D-24V, CWG-2835-120D-24V, CWG-2835-60D-5V, CWG-2835-120D-5V

Note:

This attachment only valided with Verification No.: TMC210319126-E



Leman Raa