

Installation sanleitung Installation Instruction Instruction d'installation

Importeur:	Decobus Handel GmbH
Adresse:	Immergrüner Weg 9, 21244 Buchholz, Deutschland
URL:	http://www.decobusgroup.de
Hersteller:	ZHANGZHOU LIFE FURNITURE CO.,LTD
Adresse:	NO.385 CHAGSHENG ROAD, LONGWEN DISTRICT ZHANGZHOU CITY OF JIAN PROVINCE (PLANT)
Email/URL:	shipping@lflife.furniture.cn
EC REP:	Decobus Handel GmbH Immergrüner Weg 9, 21244 Buchholz, Deutschland http://www.decobusgroup.de

SKU:N623P477913
SKU:N623P477914
SKU:N623P477915
SKU:N623P477916



Metall-Hochbett 140x200cm

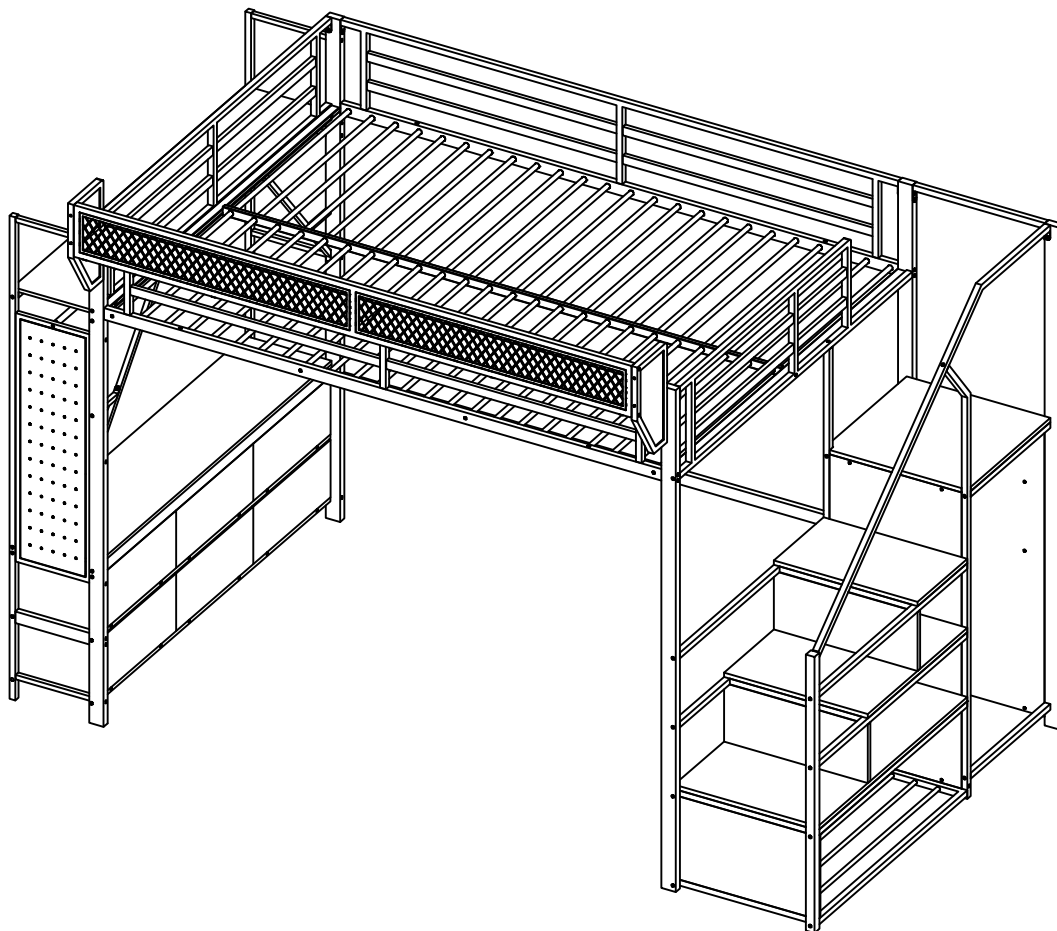

Unser Produkt wird Ihnen in 4 Paketen geliefert. Die Lieferzeiten dieser 4 Pakete können abweichen, bitte haben Sie etwas Geduld und vielen Dank für Ihr Verständnis.

Our product will be delivered to you in 4 packages. The delivery times of these 4 packages may differ, please be patient and thank you for your understanding.

Notre produit vous sera livré en 4 colis. Les délais de livraison de ces 4 colis peuvent différer, soyez patient et merci pour votre compréhension.

IMPORTANT- READ CAREFULLY-

RETAIN FOR FUTURE REFERENCE

TOP TIPS BEFORE YOU START !

1. Please check that all parts & hardware are present before you start the assembly of your furniture.
2. For ease and speed of assembly, we recommend that before you commence each step of the assembly,
Please identify all the parts required for that step.
3. We recommend that where possible, all items are assembled near to the area in which they will be placed in use,
to avoid moving the product unnecessarily once assembled.
4. For the protection of your furniture, particularly items of high gloss finish, we recommend that the product is placed on a
Protected surface during assembly to prevent any damage.
5. During assembly please take care not to over-tighten any fittings, as this may damage the product.

CARE AND MAINTENANCE OF YOUR FURNITURE

1. Please periodically check all fittings and re-tighten as necessary.
2. To clean your item, please use a damp cloth and wipe clean.
3. Never allow any kind of liquid to remain on your furniture. Absorption can cause wood to warp or finishes to de-laminate.
4. Please do not place hot items (e.g hot drinks) directly on the wood surface.
5. Please do not drag or pull your furniture.

IMPORTANT INFORMATION

1. The recommended size of mattress: (W)140cm x (L) 200cm x (H) 10cm.
2. Maximum thickness of mattress: 10cm.
3. Children should be discouraged from playing on top of this bunk bed.
4. The bunk bed should be checked periodically by the owner to ensure that the guardrail, ladder, and other components are maintained in the correct position and state of repair and that all connectors are tight.
5. A bunk bed is not to be placed near a ceiling fan unless the distance between the closest points on the ceiling fan bunk. Bed is at least 2 metres.
6. Use guardrails on both sides of upper bunk.

7. Children should play sensibly in and around the bed to avoid falling and injury.
8. The bed is designed for one person on each level only.
9. Use Ladder for entering and leaving upper bunk.
10. If the bunk bed will be placed next to the wall, the guardrail that runs the full length of the bed should be placed against The wall to prevent entrapment between the bed and the wall.
11. WARNING Do not use the bunk bed/high bed if any structural part is broken or missing.
12. Ventilation of the room is necessary in order to keep the humidity low and to prevent mould in and around the bed.
13. WARNING "high beds & the upper bed of bunk beds are not suitable for children under six years due to risk of injury from falls".
14. WARNING "children can become trapped between the bed & the wall, a roof pitch, the ceiling, adjoining pieces of furniture (e.g. cupboards) and the like. To avoid risk of serious injury the distance between the top safety barrier and the adjoining structure shall not exceed 75mm nor shall be more than 230mm".
15. WARNING: Always ensure the platform and the stairs are permanently attached to this bunk bed before use.
16. A statement to check regularly that all assembly fastenings are properly tightened;
17. Always follow the manufacturer's instructions.

STRANGULATION HAZARD:

18. Never attach or hang items to any part of the bunk bed that are not designed for use with the bed for example, but not limited to hooks, belts and jump ropes.
19. WARNING "Bunk Beds and high beds can present a serious risk of injury from strangulation if not used correctly. Never attach or hang items to any part of the bunk bed that are not designed to be used with the bed. for example, but not limited to ropes, strings, cords, hooks, belts and bags".
20. WARNING: This product must be attached to a wall or building structure.

WICHTIG - SORGFÄLTIG LESEN - FÜR SPÄTERE VERWENDUNG AUFBEWAHREN

TOP-TIPPS, BEVOR SIE STARTEN!

1. Bitte überprüfen Sie, ob alle Teile und Beschläge vorhanden sind, bevor Sie mit der Montage Ihrer Möbel beginnen.
2. Für eine einfache und schnelle Montage empfehlen wir, dass Sie vor jedem Montageschritt Bitte identifizieren Sie alle für diesen Schritt erforderlichen Teile.
3. Wir empfehlen, alle Artikel möglichst in der Nähe des Einsatzortes zu montieren.
um ein unnötiges Bewegen des Produkts nach der Montage zu vermeiden.
4. Zum Schutz Ihrer Möbel, insbesondere von Möbeln mit Hochglanzoberfläche, empfehlen wir, das Produkt auf einen
Geschützte Oberfläche während der Montage um eventuelle Beschädigungen zu vermeiden.
5. Achten Sie bei der Montage darauf, die Verschraubungen nicht zu fest anzuziehen, da dies zu einer Beschädigung des Produkts führen kann.

PFLEGE UND WARTUNG IHRER MÖBEL

1. Bitte überprüfen Sie regelmäßig alle Verschraubungen und ziehen Sie sie bei Bedarf nach.
2. Verwenden Sie zum Reinigen Ihres Artikels bitte ein feuchtes Tuch und wischen Sie ihn sauber.
3. Lassen Sie niemals Flüssigkeiten auf Ihren Möbeln zurück. Durch die Aufnahme kann sich das Holz verziehen oder die Oberfläche kann sich ablösen.
4. Bitte stellen Sie keine heißen Gegenstände (z. B. heiße Getränke) direkt auf die Holzoberfläche.
5. Bitte schleifen oder ziehen Sie Ihre Möbel nicht.

WICHTIGE INFORMATIONEN

1. Die empfohlene Matratzengröße: (W)140 cm x (L) 200 cm x (H) 10 cm.
2. Maximale Matratzendicke: 10 cm.
3. Kinder sollten davon abgehalten werden, auf diesem Etagenbett zu spielen.
4. Das Etagenbett sollte regelmäßig vom Eigentümer überprüft werden, um sicherzustellen, dass Geländer, Leiter und andere Komponenten in der richtigen Position und im richtigen Zustand gehalten werden und dass alle Verbindungselemente fest sind.
5. Ein Etagenbett darf nicht in der Nähe eines Deckenventilators aufgestellt werden, es sei denn, der Abstand zwischen den nächstgelegenen Punkten des Etagenbetts mit Deckenventilator beträgt mindestens 2 Meter.

6. Verwenden Sie an beiden Seiten der oberen Koje Schutzgeländer.
7. Kinder sollten vernünftig im und um das Bett spielen, um Stürze und Verletzungen zu vermeiden.
8. Das Bett ist auf jeder Ebene nur für eine Person ausgelegt.
9. Benutzen Sie die Leiter zum Ein- und Aussteigen aus dem oberen Bett.
10. Wenn das Etagenbett neben der Wand aufgestellt wird, sollte das über die gesamte Länge des Bettes verlaufende Schutzgeländer gegen Die Wand verhindert ein Einklemmen zwischen Bett und Wand.
11. **WARNUNG** Verwenden Sie das Etagenbett/Hochbett nicht, wenn ein Bauteil gebrochen ist oder fehlt.
12. Eine Belüftung des Zimmers ist notwendig, um die Luftfeuchtigkeit niedrig zu halten und Schimmelbildung im und um das Bett vorzubeugen.
13. **WARNUNG** „Hochbetten & das Oberbett von Etagenbetten sind wegen Verletzungsgefahr durch Stürze nicht für Kinder unter sechs Jahren geeignet.“
14. **WARNUNG:** „Kinder können zwischen Bett und Wand, einer Dachschräge, der Decke, angrenzenden Möbelstücken (z. B. Schränken) und dergleichen eingeklemmt werden. Um die Gefahr schwerer Verletzungen zu vermeiden, darf der Abstand zwischen der oberen Sicherheitsbarriere und der angrenzenden Struktur 75 mm nicht überschreiten und nicht mehr als 230 mm betragen.“
15. **WARNUNG:** Stellen Sie immer sicher, dass die Plattform und die Treppe vor dem Gebrauch dauerhaft an diesem Etagenbett befestigt sind.
16. Eine Anweisung, regelmäßig zu überprüfen, ob alle Montagebefestigungen richtig angezogen sind;
17. Befolgen Sie immer die Anweisungen des Herstellers.

STRANGULATIONSGEFAHR:

18. Befestigen oder hängen Sie niemals Gegenstände an Teilen des Etagenbetts auf, die nicht für die Verwendung mit dem Bett vorgesehen sind (z. B. Haken, Gürtel und Springseile).
19. **WARNUNG** „Bei unsachgemäßer Verwendung von Etagenbetten und Hochbetten besteht die Gefahr einer Strangulation. Befestigen oder hängen Sie niemals Gegenstände an Teilen des Etagenbetts auf, die nicht für die Verwendung mit dem Bett vorgesehen sind. Dies sind beispielsweise , jedoch nicht ausschließlich, Seile, Schnüre, Kordeln, Haken, Gürtel und Taschen.“
20. **WARNUNG:** Dieses Produkt muss an einer Wand oder einer Gebäudestruktur befestigt werden.

IMPORTANT- À LIRE ATTENTIVEMENT- À CONSERVER POUR RÉFÉRENCE FUTURE

LES BONS CONSEILS AVANT DE COMMENCER !

1. Veuillez vérifier que toutes les pièces et le matériel sont présents avant de commencer l'assemblage de vos meubles.
2. Pour faciliter et accélérer l'assemblage, nous vous recommandons, avant de commencer chaque étape de l'assemblage,

Veuillez identifier toutes les pièces requises pour cette étape.

3. Nous recommandons que, dans la mesure du possible, tous les articles soient assemblés à proximité de la zone dans laquelle ils seront utilisés,

pour éviter de déplacer inutilement le produit une fois assemblé.

4. Pour la protection de vos meubles, en particulier des articles à finition brillante, nous vous recommandons de placer le produit sur un

Surface protégée lors du montage pour éviter tout dommage.

5. Lors de l'assemblage, veillez à ne pas trop serrer les raccords, car cela pourrait endommager le produit.

SOIN ET ENTRETIEN DE VOS MEUBLES

1. Veuillez vérifier périodiquement tous les raccords et resserrer si nécessaire.
2. Pour nettoyer votre article, veuillez utiliser un chiffon humide et essuyer.
3. Ne laissez jamais aucun type de liquide rester sur vos meubles. L'absorption peut provoquer la déformation du bois ou le délaminage des finitions.
4. Veuillez ne pas placer d'objets chauds (par exemple des boissons chaudes) directement sur la surface du bois.
5. Veuillez ne pas traîner ou tirer vos meubles.

UNE INFORMATION IMPORTANT

1. La taille recommandée du matelas : (W) 140 cm x (L) 200 cm x (H) 10 cm.
2. Épaisseur maximale du matelas : 10 cm.
3. Il convient de décourager les enfants de jouer sur ce lit superposé.
4. Le lit superposé doit être vérifié périodiquement par le propriétaire pour s'assurer que le garde-corps, l'échelle et les autres composants sont maintenus dans la bonne position et en bon état et que tous les connecteurs sont bien serrés.

5. Un lit superposé ne doit pas être placé à proximité d'un ventilateur de plafond, à moins que la distance entre les points les plus proches du ventilateur de plafond ne soit respectée. Le lit mesure au moins 2 mètres.
6. Utilisez des garde-corps des deux côtés du lit supérieur.
7. Les enfants doivent jouer raisonnablement dans et autour du lit pour éviter les chutes et les blessures.
8. Le lit est conçu pour une seule personne à chaque niveau.
9. Utilisez l'échelle pour entrer et sortir du lit supérieur.
10. Si le lit superposé doit être placé près du mur, le garde-corps qui s'étend sur toute la longueur du lit doit être placé contre le mur pour éviter tout coincement entre le lit et le mur.
11. AVERTISSEMENT N'utilisez pas le lit superposé/lit surélevé si une pièce structurelle est cassée ou manquante.
12. La ventilation de la pièce est nécessaire afin de maintenir un faible taux d'humidité et d'éviter la moisissure dans et autour du lit.
13. AVERTISSEMENT "les lits hauts et le lit supérieur des lits superposés ne conviennent pas aux enfants de moins de six ans en raison du risque de blessure en cas de chute".
14. AVERTISSEMENT "Les enfants peuvent se retrouver coincés entre le lit et le mur, une pente de toit, le plafond, des meubles attenants (par exemple des placards) et autres. Pour éviter tout risque de blessure grave, la distance entre la barrière de sécurité supérieure et la barrière de sécurité adjacente la structure ne doit pas dépasser 75 mm ni dépasser 230 mm".
15. AVERTISSEMENT: Vérifiez toujours que la plate-forme et l'escalier sont fixés de manière permanente à ce lit superposé avant de l'utiliser.
16. Une déclaration demandant de vérifier régulièrement que toutes les fixations de l'assemblage sont correctement serrées ;
17. Suivez toujours les instructions du fabricant.

RISQUE D'ÉTRANGULATION :

18. N'attachez ou ne suspendez jamais d'objets à une partie du lit superposé qui ne sont pas conçus pour être utilisés avec le lit, par exemple, mais sans s'y limiter, des crochets, des ceintures et des cordes à sauter.
19. AVERTISSEMENT "Les lits superposés et les lits hauts peuvent présenter un risque sérieux de blessure par strangulation s'ils ne sont pas utilisés correctement. N'attachez ou ne suspendez jamais d'objets à une partie du lit superposé qui ne sont pas conçus pour être utilisés avec le lit. par exemple, mais sans s'y limiter, les cordes, ficelles, cordons, crochets, ceintures et sacs".
20. AVERTISSEMENT : Ce produit doit être fixé à un mur ou à la structure d'un bâtiment.

IMPORTANTE- LEER CON ATENCIÓN- CONSERVAR PARA FUTURA REFERENCIA

¡MEJORES CONSEJOS ANTES DE COMENZAR!

1. Verifique que todas las piezas y herrajes estén presentes antes de comenzar a ensamblar sus muebles.

2. Para facilitar y acelerar el montaje, recomendamos que antes de comenzar cada paso del montaje,

Identifique todas las piezas necesarias para ese paso.

3. Recomendamos que, siempre que sea posible, todos los artículos se monten cerca del área en la que se utilizarán.

para evitar mover el producto innecesariamente una vez montado.

4. Para la protección de sus muebles, especialmente los artículos con acabado de alto brillo, recomendamos colocar el producto sobre una

Superficie protegida durante el montaje para evitar cualquier daño.

5. Durante el montaje, tenga cuidado de no apretar demasiado ningún accesorio, ya que esto podría dañar el producto.

CUIDADO Y MANTENIMIENTO DE TUS MUEBLES

1. Revise periódicamente todos los accesorios y vuelva a apretarlos según sea necesario.

2. Para limpiar su artículo, utilice un paño húmedo y límpielo.

3. Nunca permita que quede ningún tipo de líquido en sus muebles. La absorción puede causar que la madera se deforme o que los acabados se deslaminen.

4. No coloque artículos calientes (por ejemplo, bebidas calientes) directamente sobre la superficie de madera.

5. No arrastre ni tire de sus muebles.

INFORMACIÓN IMPORTANTE

1. El tamaño recomendado del colchón: (W)140 cm x (L) 200 cm x (H) 10 cm.

2. Grosor máximo del colchón: 10cm.

3. Se debe disuadir a los niños de jugar encima de esta litera.

4. El propietario debe revisar periódicamente la litera para garantizar que la barandilla, la escalera y otros componentes se mantengan en la posición y estado correctos y que todos los conectores estén apretados.

5. No se debe colocar una litera cerca de un ventilador de techo a menos que la distancia entre los puntos más cercanos de la litera del ventilador de techo. La cama mide al menos 2 metros.
6. Utilice barandillas a ambos lados de la litera superior.
7. Los niños deben jugar con sensatez dentro y alrededor de la cama para evitar caídas y lesiones.
8. La cama está diseñada para una persona en cada nivel únicamente.
9. Utilice la escalera para entrar y salir de la litera superior.
10. Si la litera se va a colocar junto a la pared, la barandilla que recorre toda la longitud de la cama debe colocarse contra la pared para evitar atrapamientos entre la cama y la pared.
11. ADVERTENCIA No utilice la litera/cama alta si alguna pieza estructural está rota o falta.
12. La ventilación de la habitación es necesaria para mantener baja la humedad y evitar moho dentro y alrededor de la cama.
13. ADVERTENCIA "Las camas altas y la cama superior de las literas no son adecuadas para niños menores de seis años debido al riesgo de lesiones por caídas".
14. ADVERTENCIA "Los niños pueden quedar atrapados entre la cama y la pared, la pendiente del tejado, el techo, los muebles contiguos (por ejemplo, armarios) y similares. Para evitar el riesgo de lesiones graves, la distancia entre la barrera de seguridad superior y la barrera de seguridad contigua La estructura no excederá los 75 mm ni excederá los 230 mm".
15. ADVERTENCIA: Asegúrese siempre de que la plataforma y la escalera están fijadas permanentemente a esta litera antes de su uso.
16. Una declaración para comprobar regularmente que todas las fijaciones de montaje están bien apretadas;
17. Siga siempre las instrucciones del fabricante.

PELIGRO DE ESTRANGULACIÓN:

18. Nunca coloque ni cuelgue elementos en ninguna parte de la litera que no estén diseñados para usarse con la cama, por ejemplo, entre otros, ganchos, cinturones y cuerdas para saltar.
19. ADVERTENCIA "Las literas y las camas altas pueden presentar un riesgo grave de lesiones por estrangulamiento si no se usan correctamente. Nunca fije ni cuelgue elementos en ninguna parte de la litera que no estén diseñados para usarse con la cama, por ejemplo, pero no limitado a cuerdas, cordeles, cordones, ganchos, cinturones y bolsas".
20. ADVERTENCIA: Este producto debe fijarse a una pared o a la estructura de un edificio.

IMPORTANTE - LEGGERE ATTENTAMENTE -

CONSERVARE PER RIFERIMENTO FUTURO

I MIGLIORI CONSIGLI PRIMA DI INIZIARE!

1. Verificare che tutte le parti e l'hardware siano presenti prima di iniziare l'assemblaggio dei mobili.
2. Per facilitare e velocizzare l'assemblaggio, si consiglia prima di iniziare ogni fase dell'assemblaggio, identificare tutte le parti necessarie per questo passaggio.
3. Raccomandiamo, ove possibile, che tutti gli articoli siano assemblati vicino all'area in cui verranno utilizzati, per evitare di spostare inutilmente il prodotto una volta assemblato.
4. Per la protezione dei tuoi mobili, in particolare degli articoli con finitura lucida, ti consigliamo di posizionare il prodotto su a Superficie protetta durante il montaggio per evitare eventuali danni.
5. Durante il montaggio fare attenzione a non stringere eccessivamente i raccordi, poiché ciò potrebbe danneggiare il prodotto.

CURA E MANUTENZIONE DEI VOSTRI MOBILI

1. Controllare periodicamente tutti i raccordi e serrarli nuovamente se necessario.
2. Per pulire l'articolo, utilizzare un panno umido e pulirlo.
3. Non lasciare mai alcun tipo di liquido sui mobili. L'assorbimento può causare la deformazione del legno o la delaminazione delle finiture.
4. Si prega di non posizionare oggetti caldi (ad esempio bevande calde) direttamente sulla superficie del legno.
5. Si prega di non trascinare o tirare i mobili.

INFORMAZIONI IMPORTANTI

1. Dimensioni consigliate del materasso: (W) 140 cm x (L) 200 cm x (H) 10 cm.
2. Spessore massimo del materasso: 10 cm.
3. I bambini dovrebbero essere scoraggiati dal giocare sul letto a castello.
4. Il letto a castello deve essere controllato periodicamente dal proprietario per garantire che il parapetto, la scala e gli altri componenti siano mantenuti nella posizione corretta e in stato di riparazione e che tutti i connettori siano serrati.
5. Un letto a castello non deve essere posizionato vicino a un ventilatore da soffitto, a meno che non sia rispettata la distanza tra i punti più vicini sul letto a castello. Il letto è di almeno 2 metri.

6. Utilizzare le sponde su entrambi i lati del letto superiore
7. I bambini dovrebbero giocare in modo sensato dentro e intorno al letto per evitare cadute e lesioni.
8. Il letto è previsto per una sola persona su ogni livello.
9. Usa la scala per entrare e uscire dalla cuccetta superiore.
10. Se il letto a castello verrà posizionato vicino al muro, la ringhiera che corre per tutta la lunghezza del letto deve essere posizionata contro il muro per evitare intrappolamenti tra il letto e il muro.
11. **ATTENZIONE** Non utilizzare il letto a castello/letto sopraelevato se qualche parte strutturale è rotta o mancante.
12. La ventilazione della stanza è necessaria per mantenere bassa l'umidità e prevenire la formazione di muffe all'interno e attorno al letto.
13. **ATTENZIONE** "I letti alti e il letto superiore dei letti a castello non sono adatti a bambini di età inferiore a sei anni a causa del rischio di lesioni dovute a cadute".
14. **AVVERTENZA** "I bambini possono rimanere intrappolati tra il letto e il muro, la falda del tetto, il soffitto, i mobili adiacenti (ad esempio armadi) e simili. Per evitare il rischio di lesioni gravi, la distanza tra la barriera di sicurezza superiore e quella adiacente la struttura non deve superare i 75 mm né essere superiore ai 230 mm".
15. **AVVERTENZA:** Assicurarsi sempre che la piattaforma e la scala siano fissate in modo permanente a questo letto a castello prima dell'uso.
16. Una dichiarazione di controllare regolarmente che tutti i fissaggi di montaggio siano correttamente serrati;
17. Seguire sempre le istruzioni del produttore.

PERICOLO DI STRANGOLAMENTO:

18. Non attaccare o appendere mai oggetti a qualsiasi parte del letto a castello che non siano progettati per l'uso con il letto, ad esempio, ma non limitati a ganci, cinture e corde per saltare.
19. **AVVERTENZA** "I letti a castello e i letti alti possono presentare un grave rischio di lesioni da strangolamento se non utilizzati correttamente. Non attaccare o appendere mai oggetti a qualsiasi parte del letto a castello che non siano progettati per essere utilizzati con il letto, ad esempio, ma non limitato a corde, spaghi, corde, ganci, cinture e borse".
20. **AVVERTENZA:** Questo prodotto deve essere fissato a una parete o a una struttura dell'edificio.

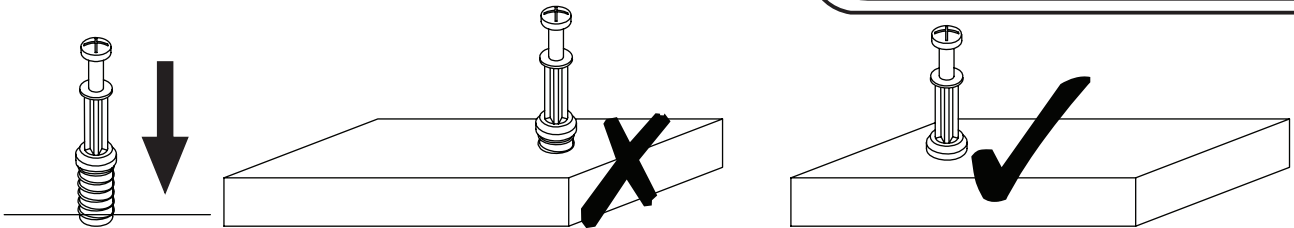

EN_QUICKFIT: Tighten quickfit until shoulder is flush with panel. Do not overtighten or undertighten.

FR_RACCORD RAPIDE: Faites serrer le raccord rapide jusqu'à ce que l'épaulement soit parfaitement encastré dans le panneau. Il ne faut ni trop serrer ni insuffisamment serrer.

ES_QUICKFIT: Apriete quickfit hasta que el hombro se descargue con el panel. NO lo sobreapriete ni lo apriete poco.

DE_QUICKFIT: Ziehen Sie den Quickfit fest, bis die Schulter mit der Platte bündig ist. Bitte nicht zu fest oder zu schwach anziehen.

IT_MONTAGGIO RAPIDO: Stringere il montaggio rapido fino a quando la spalla è a filo con il pannello, non stringere troppo o troppo poco.

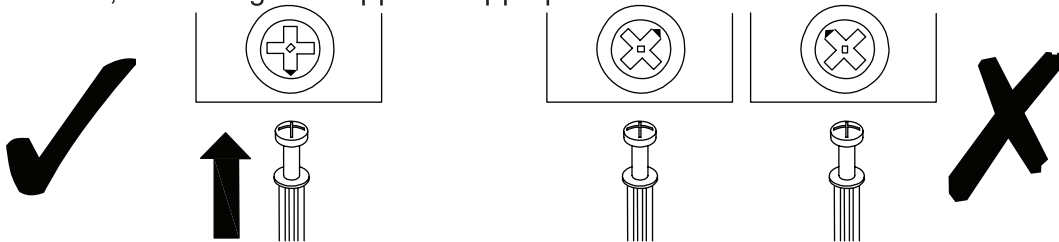

EN_CAM LOCK: When fitting cam lock, ensure starting position is correct before you insert connecting quickfit.

FR_SERRURE BATTEUSE: Avant d'insérer la serrure batteuse, veillez à la bonne orientation avant d'insérer le raccord rapide.

ES_CIERRE DE LA CÁMARA: Cuando instale el cierre de la cámara, asegúrese de que la posición de inicio es correcta antes de que inserte el quickfit conector.

DE_CAM-LOCK: Achten Sie bei der Montage des Cam-Locks auf die richtige Ausgangsposition, bevor Sie den Quickfit einsetzen.

IT_BLOCCAGGIO A CAMMA: Quando si monta il bloccaggio a camma, assicurarsi che la posizione iniziale sia corretta prima di inserire il montaggio rapido di collegamento.

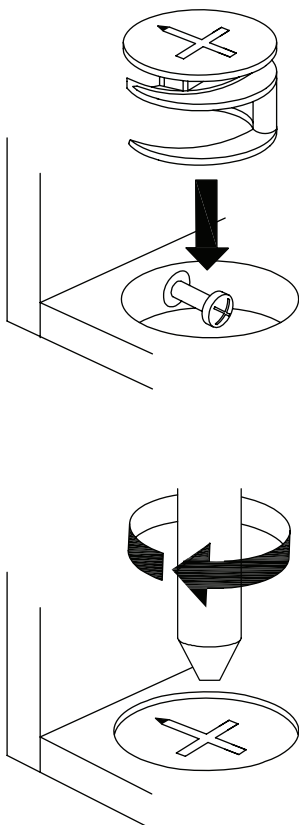

EN_Quickfit head should be in the centre of the cam lock when the two panels are joined.

Cam lock should be inserted before quickfit.

FR_Lorsque les deux panneaux sont assemblés, la tête du raccord rapide doit reposer au centre de la serrure batteuse. Il faut insérer la serrure batteuse avant le raccord rapide.

ES_El cabezal del quickfit debe estar en el centro del cierre de la cámara cuando se unan los dos paneles.

Se debe insertar el cierre de la cámara antes que el quickfit.

DE_Der Quickfit-Kopf sollte sich in der Mitte des Cam-Locks befinden, wenn die beiden Platten zusammengefügt sind.

Der Cam-Lock sollte vor dem Quickfit eingesetzt werden.

IT_La testa del montaggio rapido deve trovarsi al centro del bloccaggio a camma quando i due pannelli sono uniti.

Il Bloccaggio a Camma deve essere inserito prima del montaggio rapido.

EN_Turn cam lock clockwise to tighten.

FR_Faites tourner la serrure batteuse dans le sens des aiguilles d'une montre pour la resserrer.

ES_Gire el cierre de la cámara en sentido horario para apretarlo.

DE_Drehen Sie den Cam-Lock im Uhrzeigersinn, um ihn festzuziehen.

IT_Ruotare il bloccaggio a camma in senso orario per stringere.

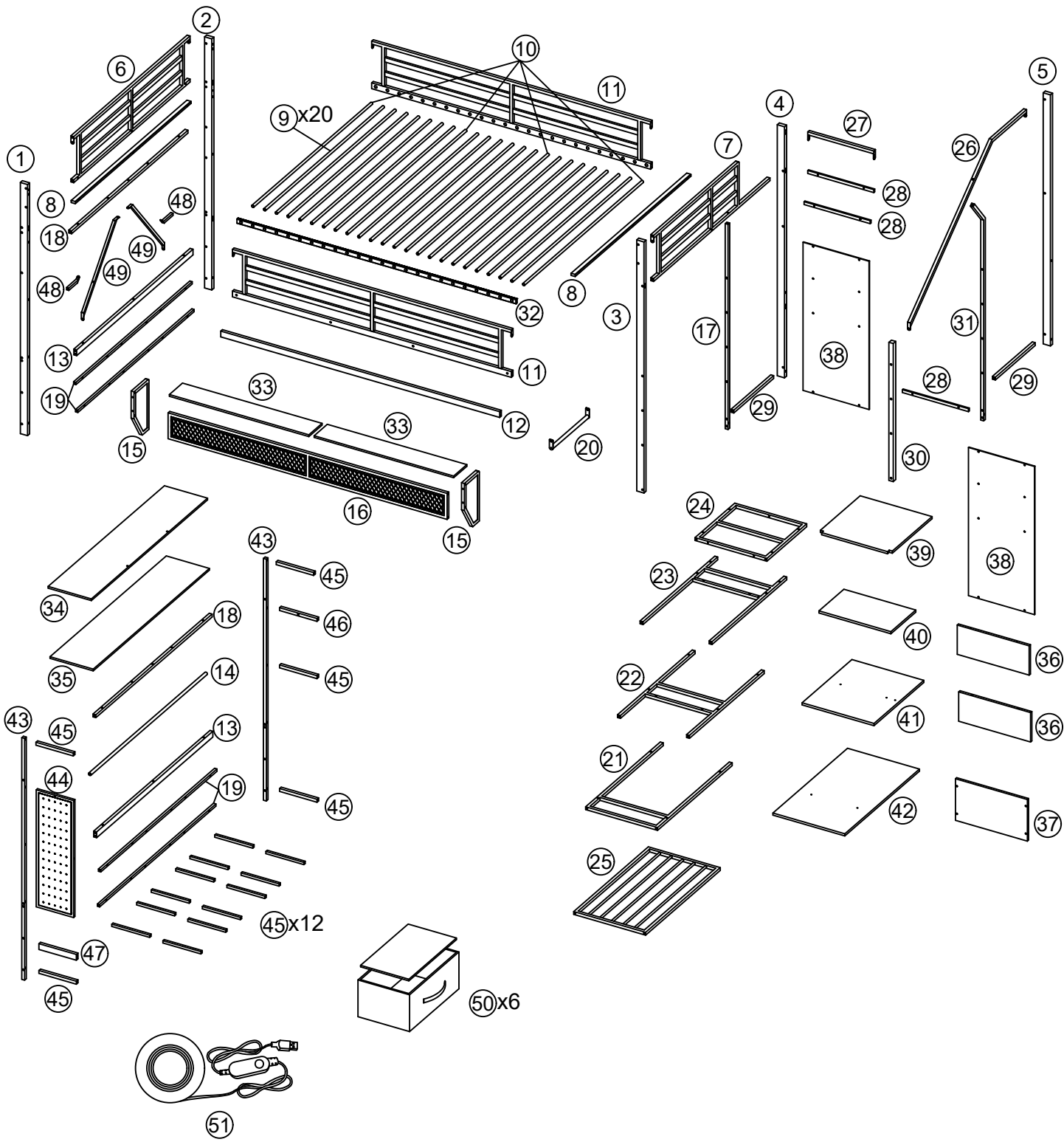

Parts List For N623P477913

11

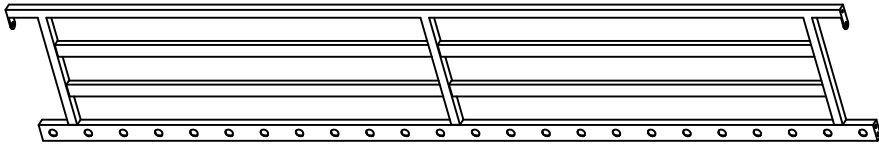

2pcs

12

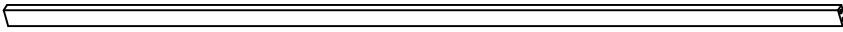

1pc

13

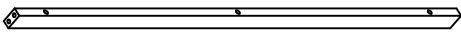

2pcs

16

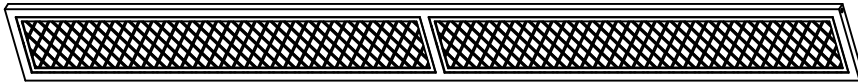

1pc

18

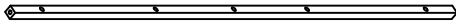

2pcs

19

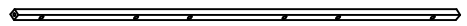

4pcs

26

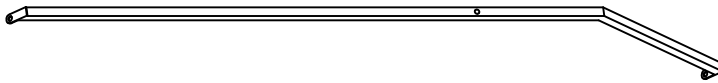

1pc

27

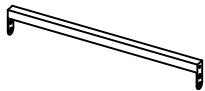

1pc

28

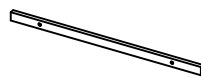

3pcs

29

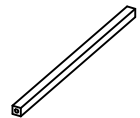

2pcs

31



1pc

32

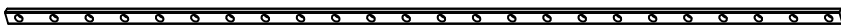

1pc

43

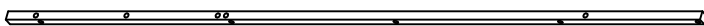

2pcs

48

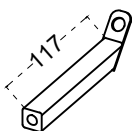

2pcs

49

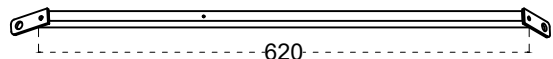

2pcs

Parts List For N623P477914

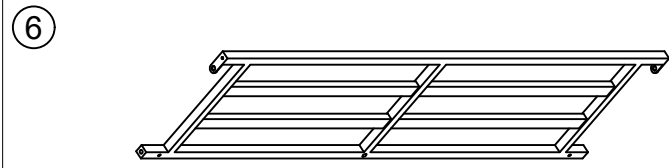

1pc

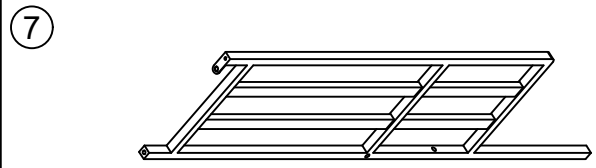

1pc



2pcs



1pc

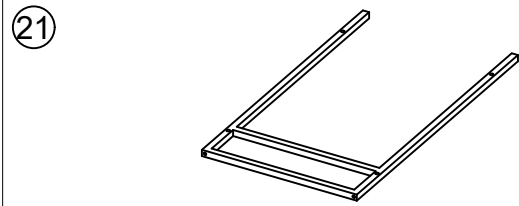

1pc

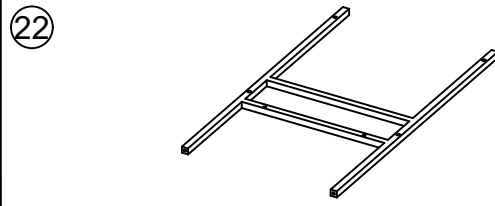

1pc

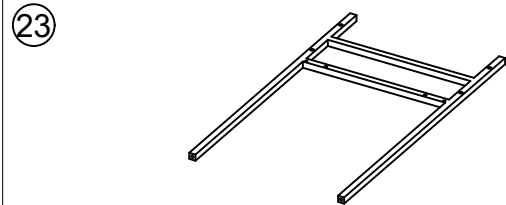

1pc

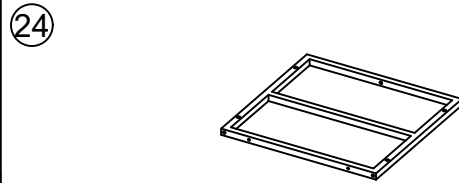

1pc

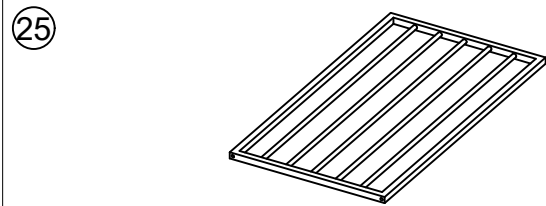

1pc

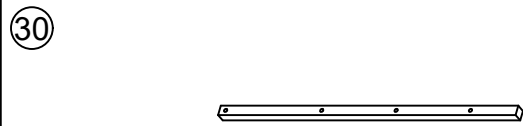

1pc

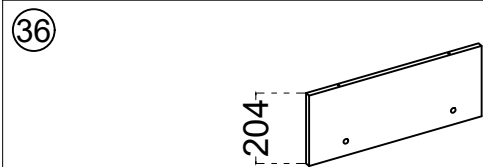

2pcs

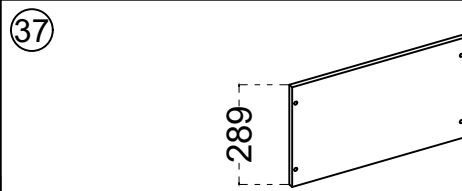

1pc

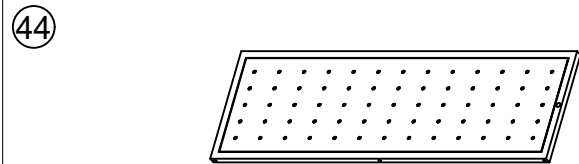

1pc

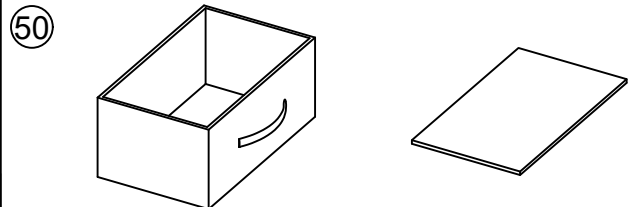

6pcs

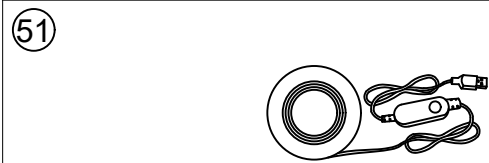

1pc

Parts List For N623P477915

34

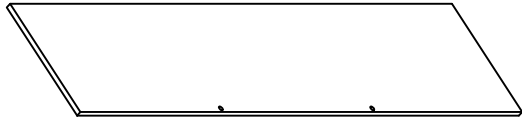

1pc

35

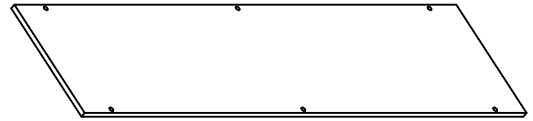

1pc

38

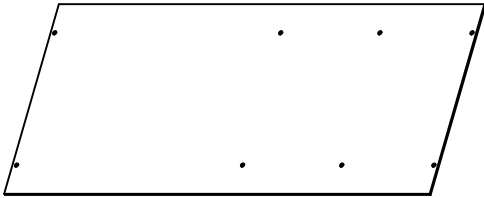

2pcs

39

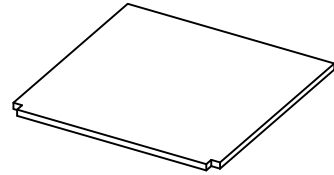

1pc

40

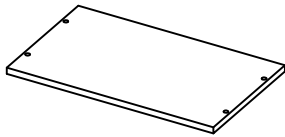

1pc

41

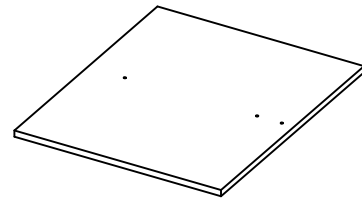

1pc

42

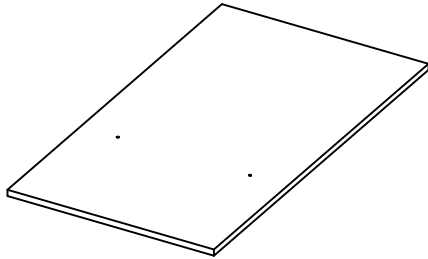





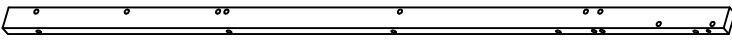
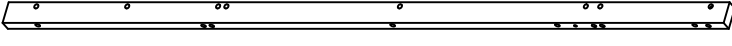
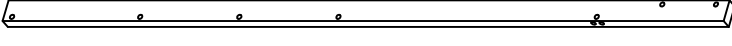
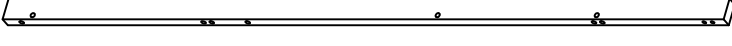
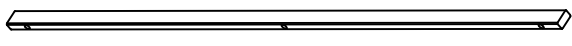
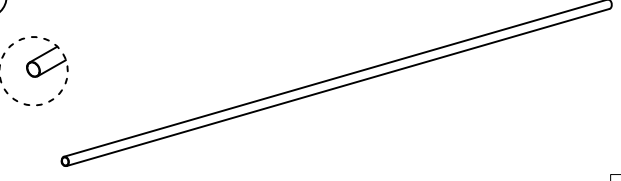
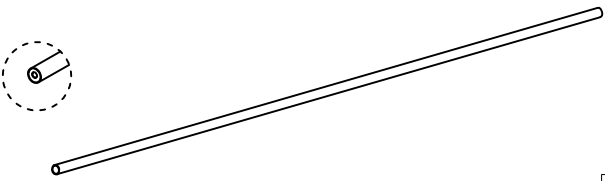
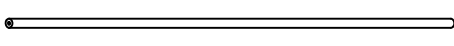
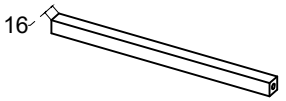
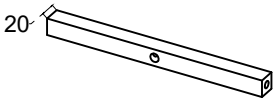
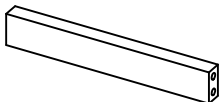
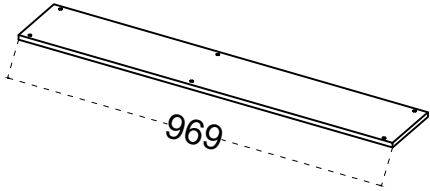



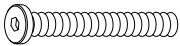
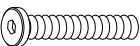
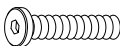
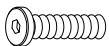

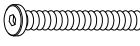

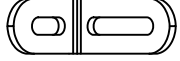
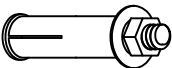

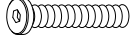
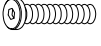



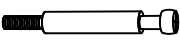

1pc

Parts List For N623P477916

①		1pc
②		1pc
③		1pc
④		1pc
⑤		1pc
⑧		2pcs
⑨	⑩	
		20pcs
⑭	⑮	
		1pc
⑯	⑰	
		1pc
⑳	㉑	
		2pcs

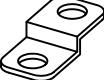
Hardware List For N623P477914



<p>(A)  M8×70mm 15pcs</p>	<p>(B)  M8×50mm 14pcs</p>	<p>(C)  M8×40mm 24pcs</p>	<p>(D)  M8×35mm 17pcs</p>
<p>(E)  M8×20mm 13pcs</p>	<p>(F)  M6×70mm 6pcs</p>	<p>(G)  M6×65mm 8pcs</p>	<p>(H)  2pcs</p>
<p>(I)  2pcs</p>	<p>(J)  1pc</p>	<p>(K)  M6×48mm 6pcs</p>	<p>(L)  M6×40mm 16pcs</p>
<p>(M)  M6×30mm 62pcs</p>	<p>(N)  M6×15mm 16pcs</p>	<p>(O)  M6×12mm 32pcs</p>	<p>(P)  M5×40mm 4pcs</p>
<p>(Q)  M5×20mm 4pcs</p>	<p>(R)  6×45mm 4pcs</p>	<p>(S)  Ø15×12mm 4pcs</p>	<p>(T)  M4 1pc</p>
<p>(U)  M5 1pc</p>	<p>(V)  1pc</p>	<p>(W)  2pcs</p>	<p>(X)  6pcs</p>
<p>(Y)  12pcs</p>	<p>(Z)  4pcs</p>		

Vor dem Einbau die Schrauben in die Löcher stecken und festziehen, aber nicht bis 100%, 70% bis 80% anziehen reicht aus. Schließlich, nachdem alle Schrauben installiert sind, ziehen Sie alle Schrauben auf 100%. Wenn Sie auf diese Probleme stoßen, wie z. B. Fehlausrichtung der Löcher oder Unfähigkeit, bestimmte Teile zu installieren, überprüfen Sie bitte, ob die Schrauben korrekt verwendet werden und passen Sie die Dichtigkeit der Schrauben an.

Before installation, insert the screws into the holes and tighten them, but do not tighten them to 100%, 70% to 80% is sufficient. Finally, after all screws are installed, tighten all screws to 100%. If you encounter these issues, such as if the holes cannot be aligned or some parts cannot be installed, please check if the screws are used correctly and adjust the tightness of the screws.



Insérer la vis dans le trou avant la fin de l'assemblage, serrer la vis, mais ne pas serrer à 100%, 70% ~ 80% est correct. Enfin, une fois que toutes les vis sont bien serrées, toutes les vis sont serrées à 100%. Si vous rencontrez ces problèmes, par exemple si les trous ne sont pas alignés ou si certaines pièces ne peuvent pas être montées, vérifiez que les vis sont utilisées correctement et Ajustez leur serrage.

1

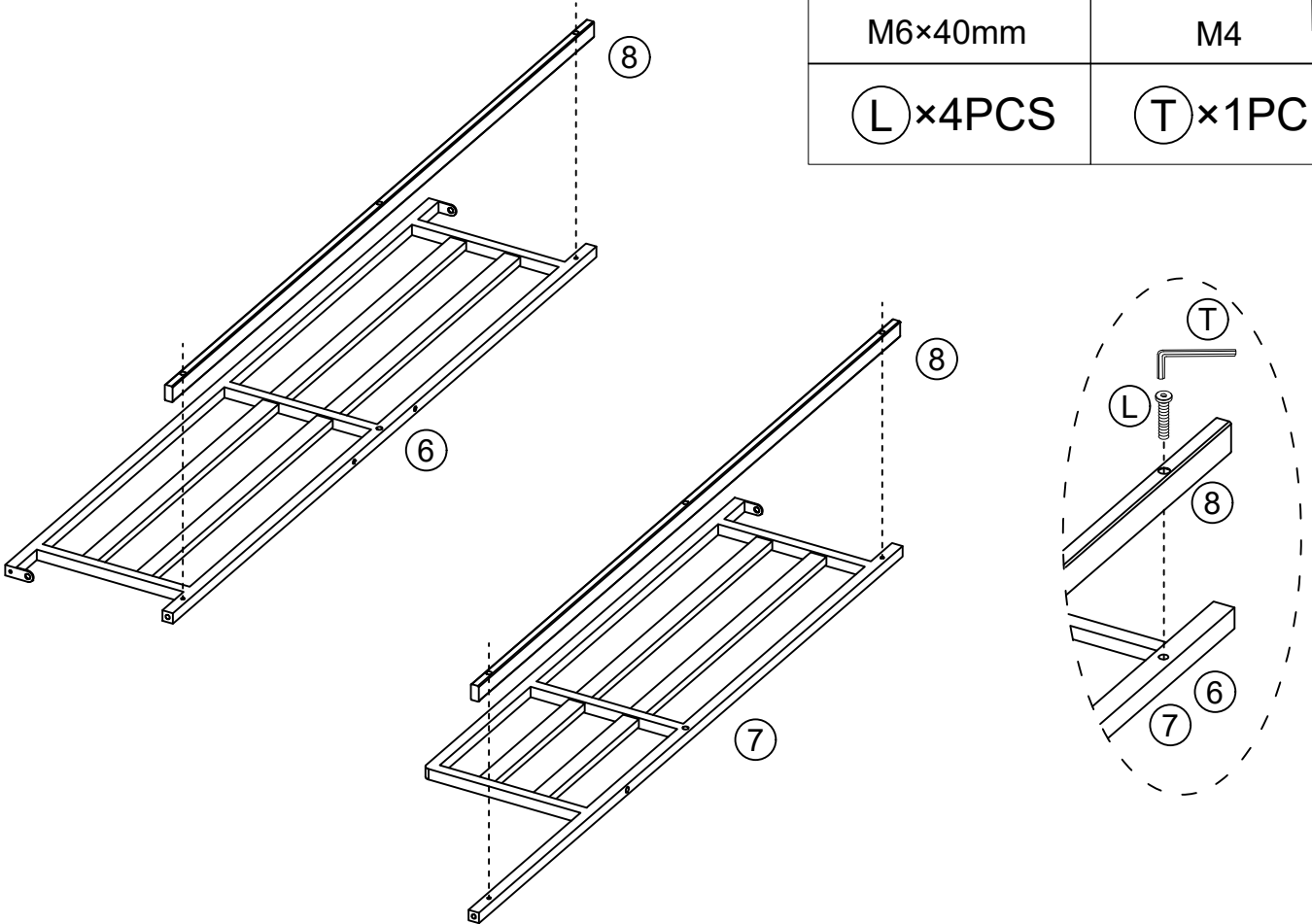
 M6×40mm	 M4
(L)×4PCS	(T)×1PC

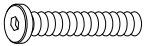
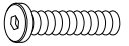

2

 M8×50mm	 M8×40mm	 M8×20mm	 M5
(B)×4PCS	(C)×2PCS	(E)×2PCS	(U)×1PC

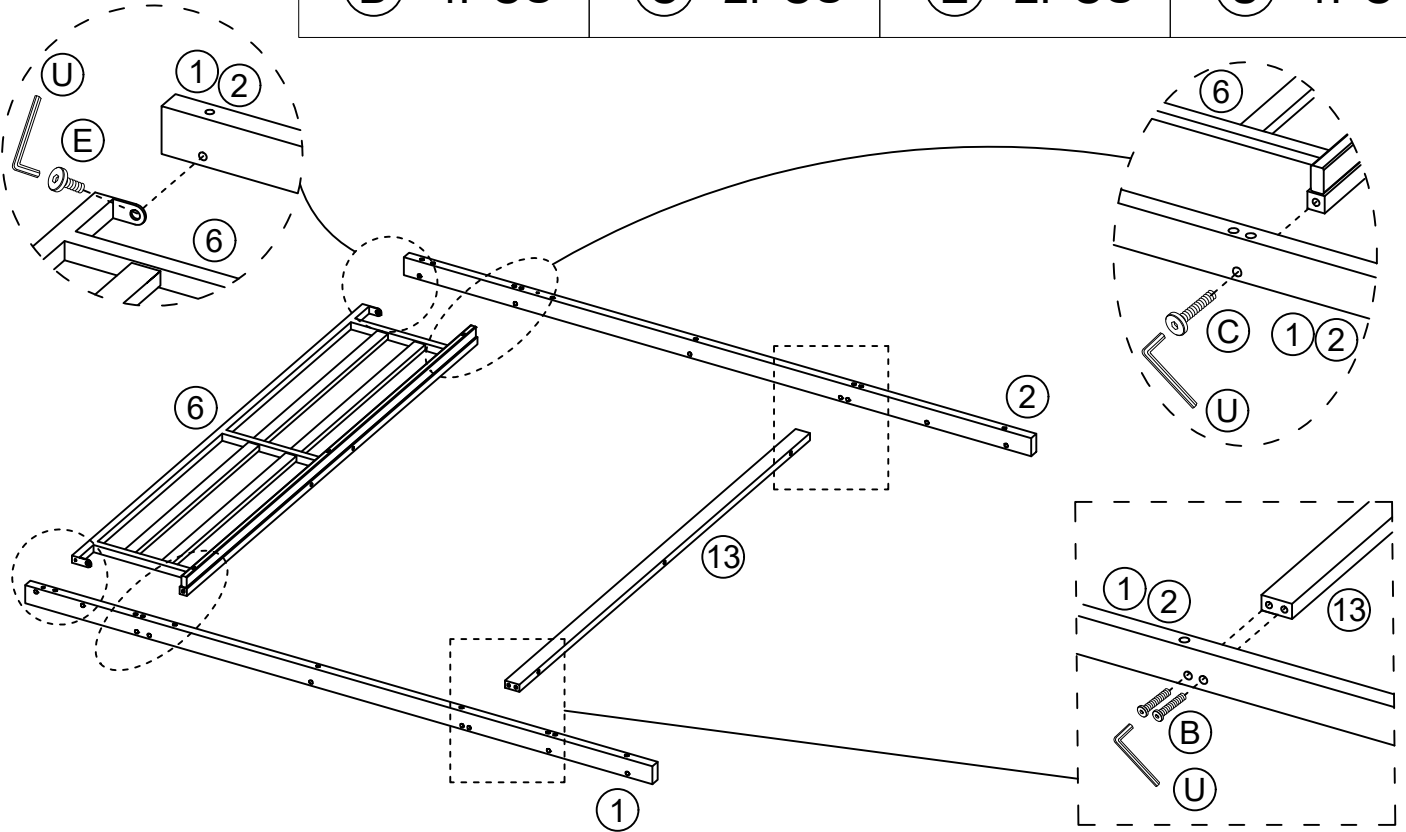

3



M8x40mm

(C) x 2PCS



M8x20mm

(E) x 1PC



M5

(U) x 1PC

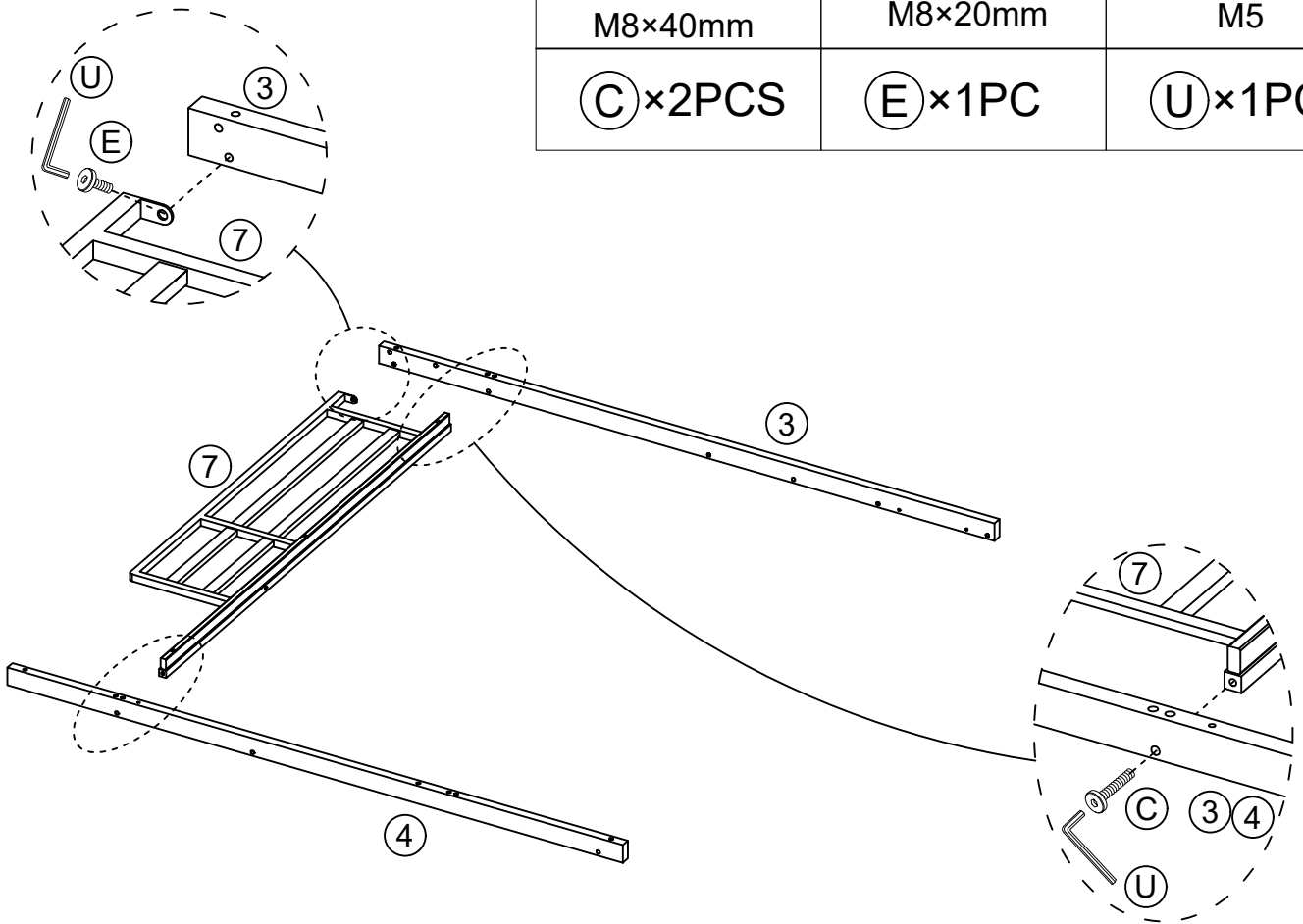

4



M6*15mm

(N) x 4PCS



M4

(T) x 1PC

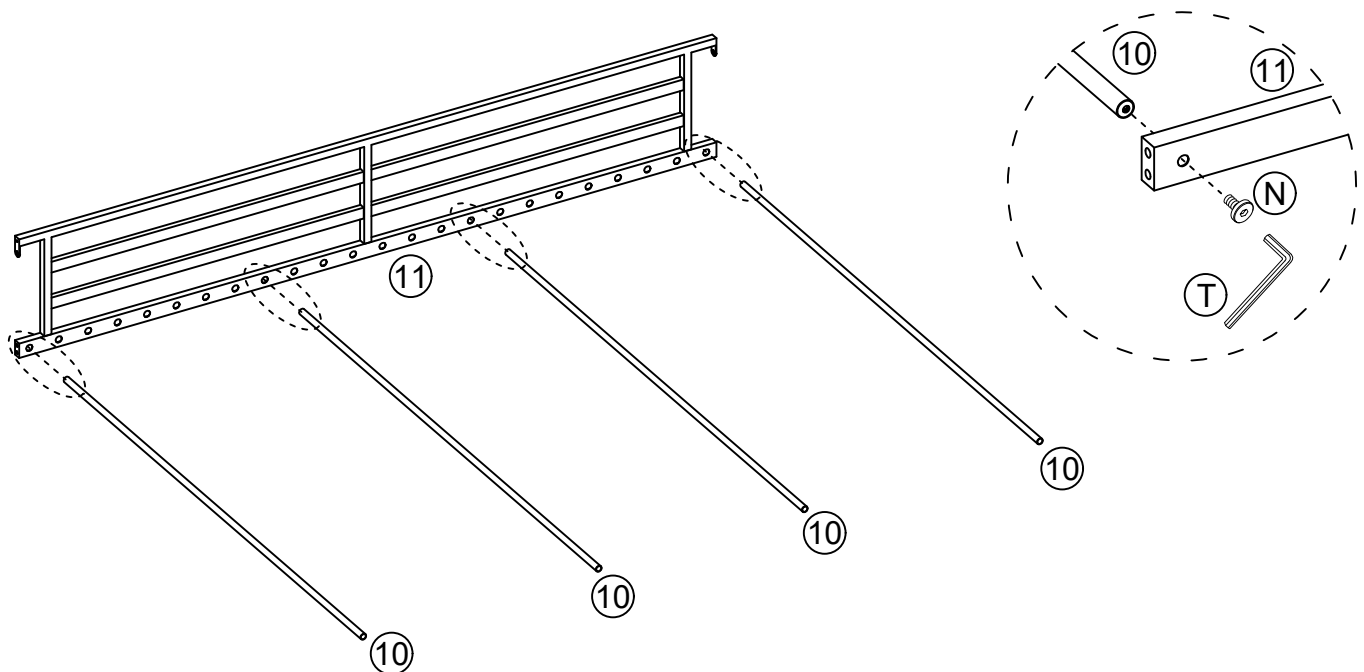

5

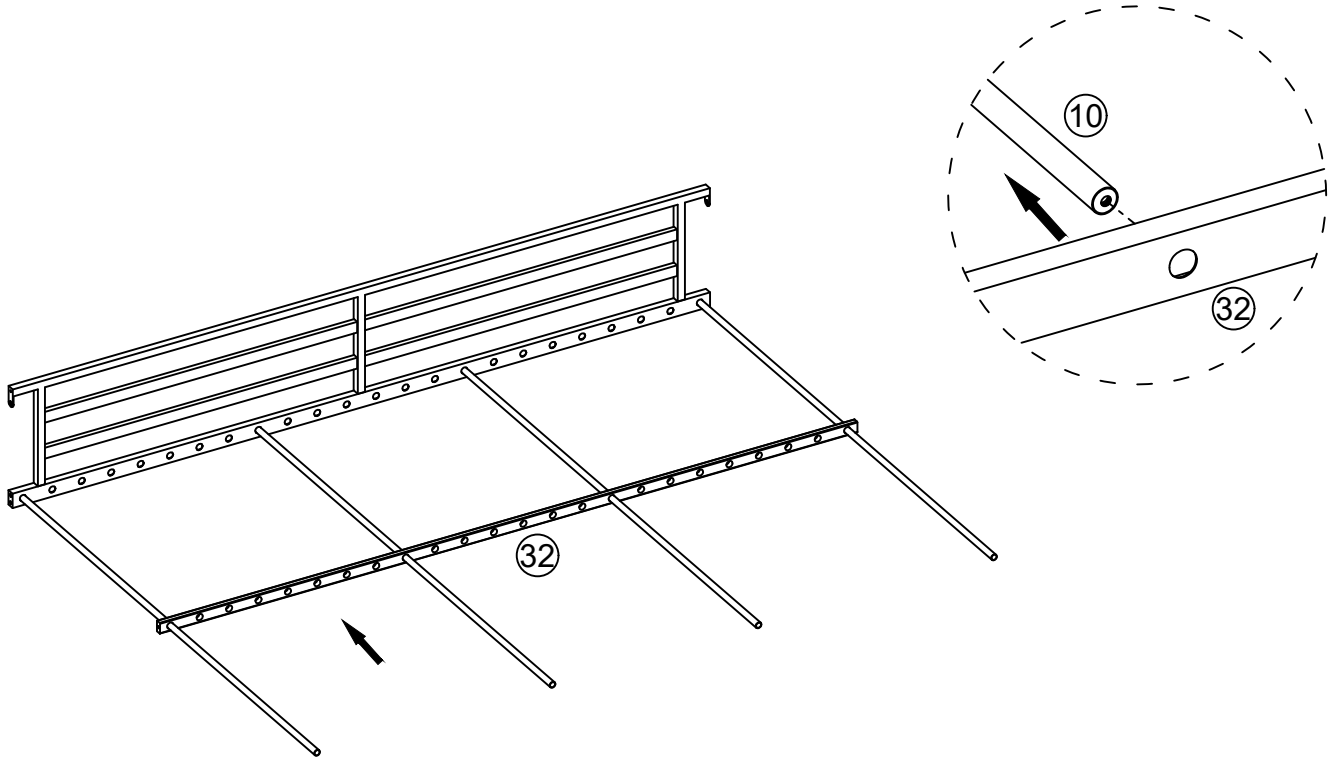

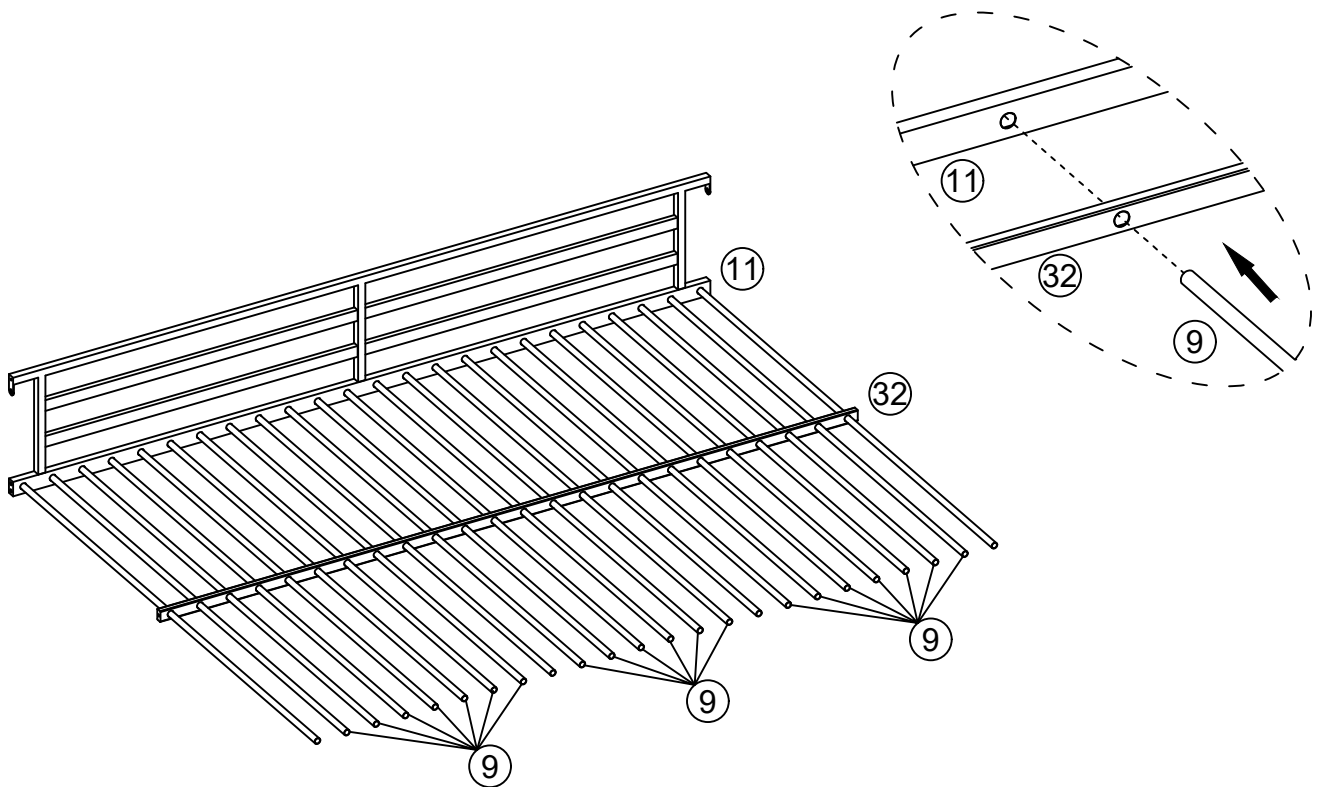

6

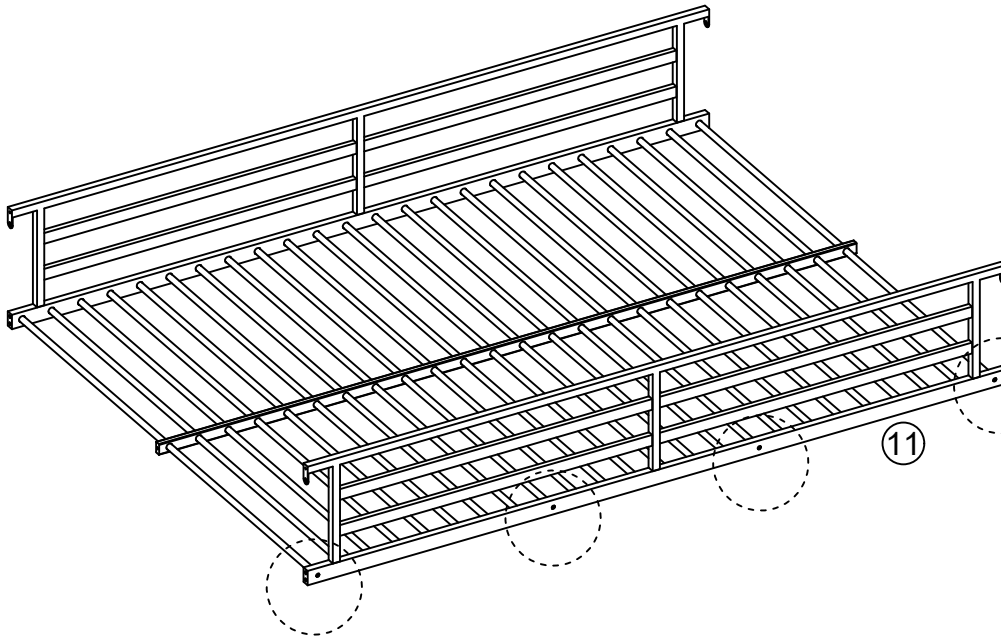

7



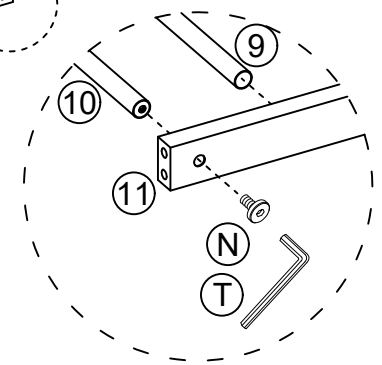

 M6*15mm	 M4
(N) × 4PCS	(T) × 1PC

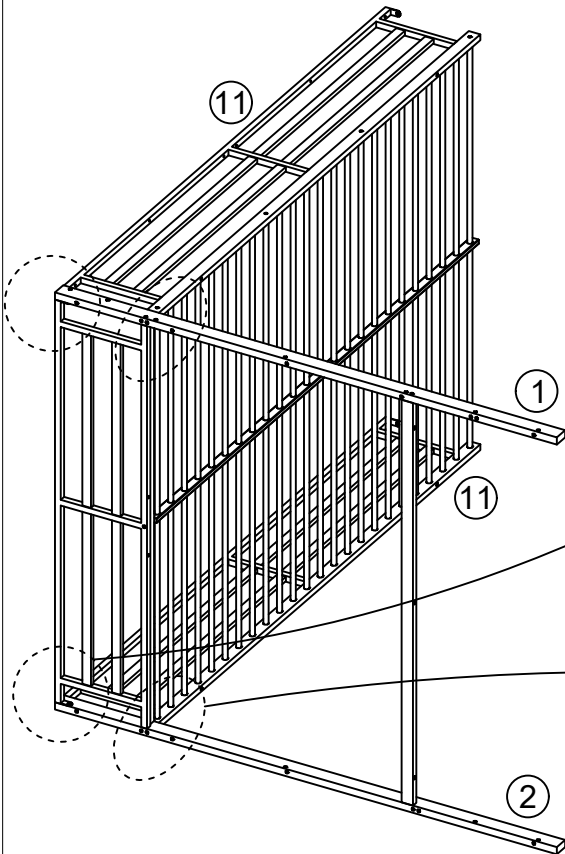

8

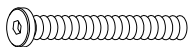

 M8*70mm	 M8*20mm	 M5
(A) × 4PCS	(E) × 2PCS	(U) × 1PC

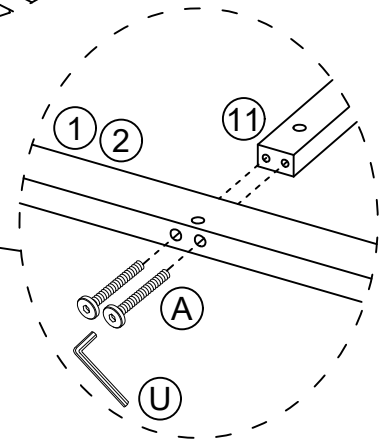
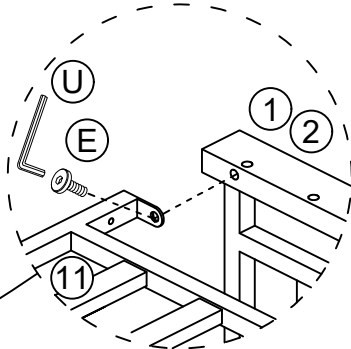

9



M8*70mm

(A) × 4PCS



M8×20mm

(E) × 2PCS



M5

(U) × 1PC

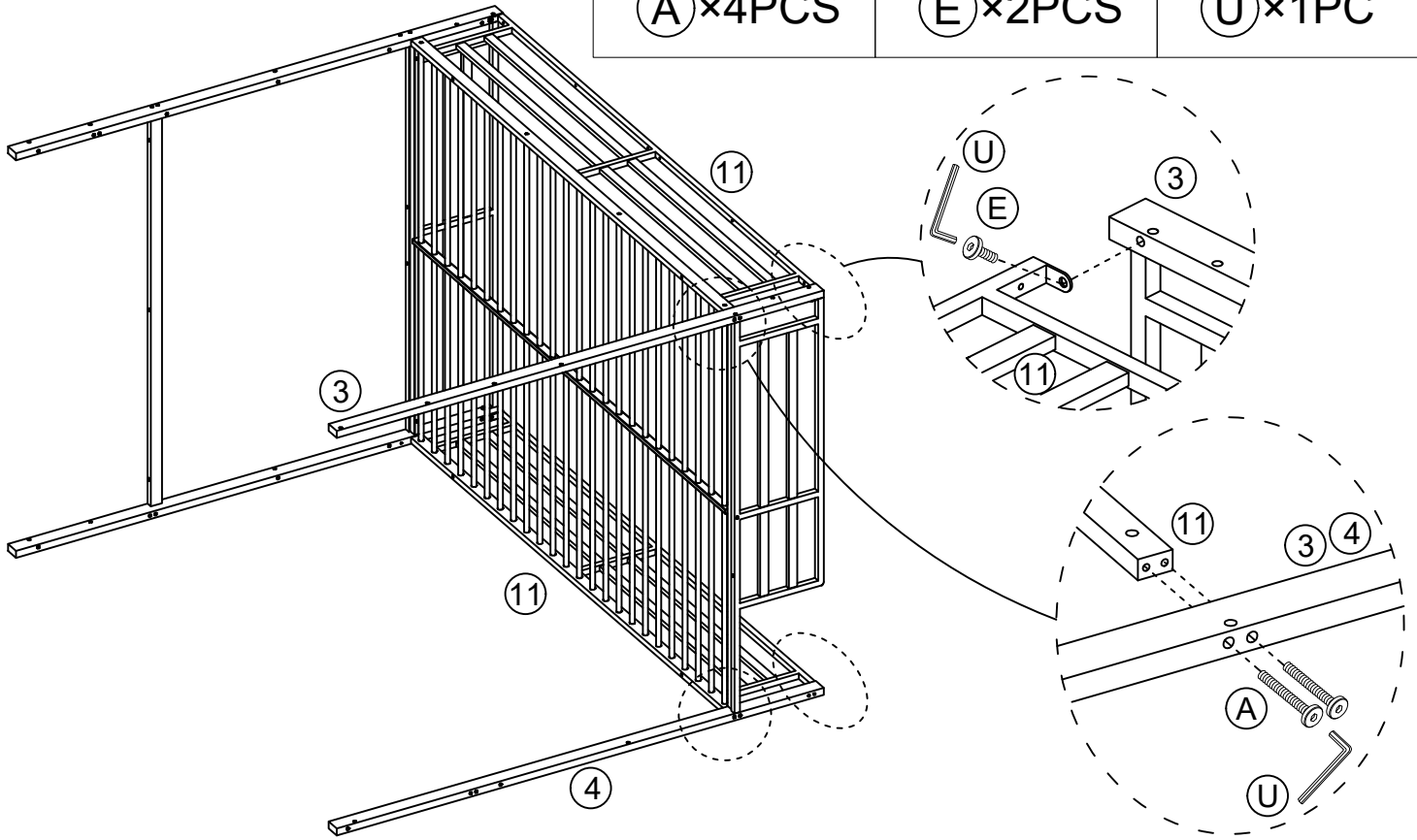

10

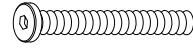

M6*70mm

(F) × 2PCS



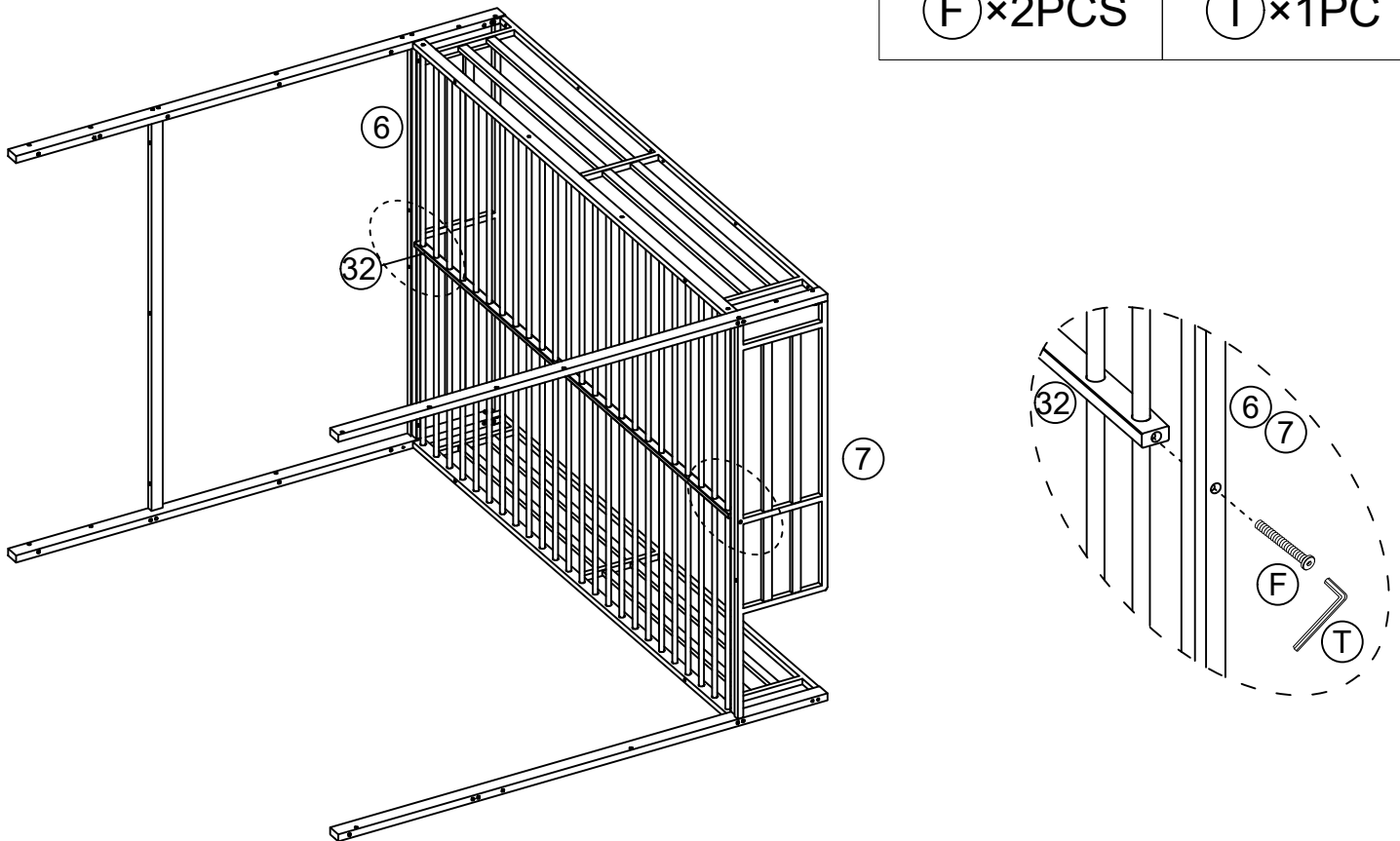

M4

(T) × 1PC



11

	
M6*12mm	M4
O × 6PCS	T × 1PC

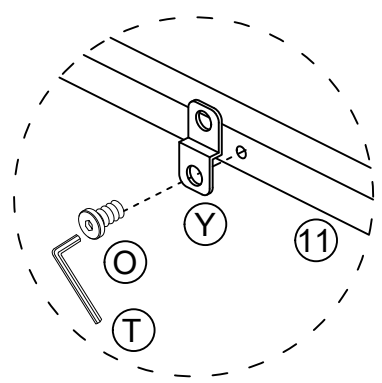
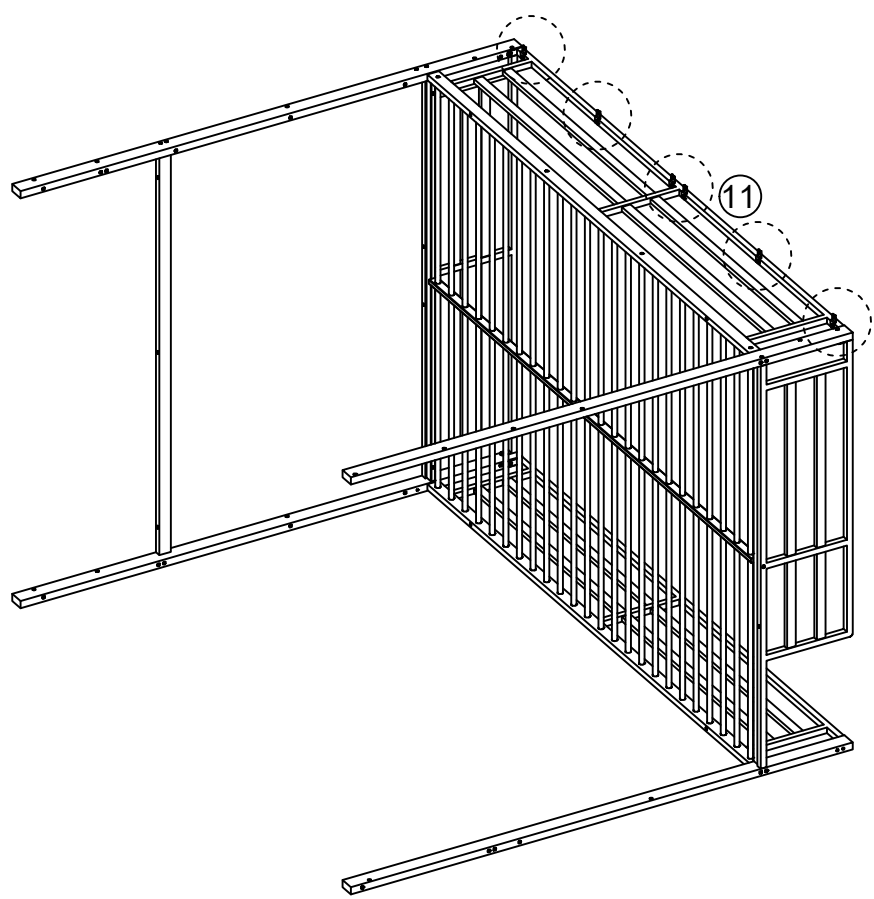

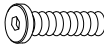
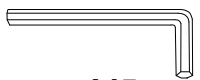

12

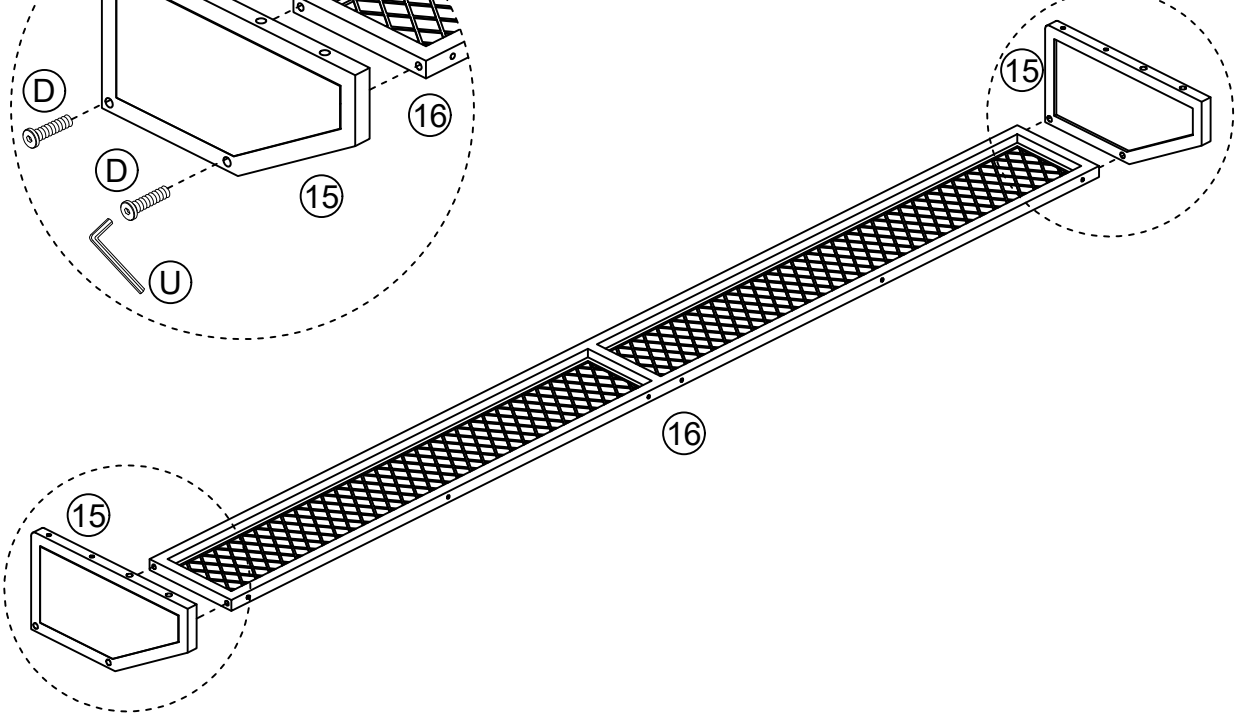
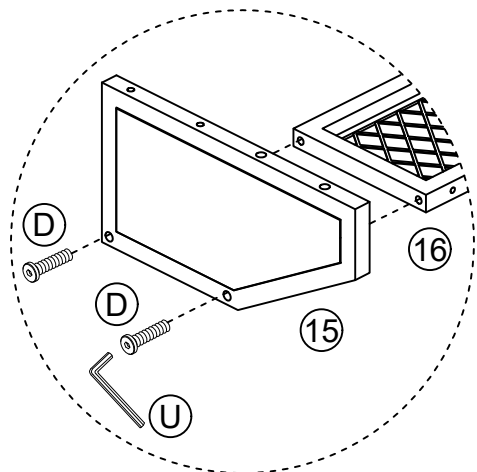
	
M8*35mm	M5
D × 4PCS	U × 1PC



13

 M6*12mm	 M4
⊙×6PCS	⊕×1PC

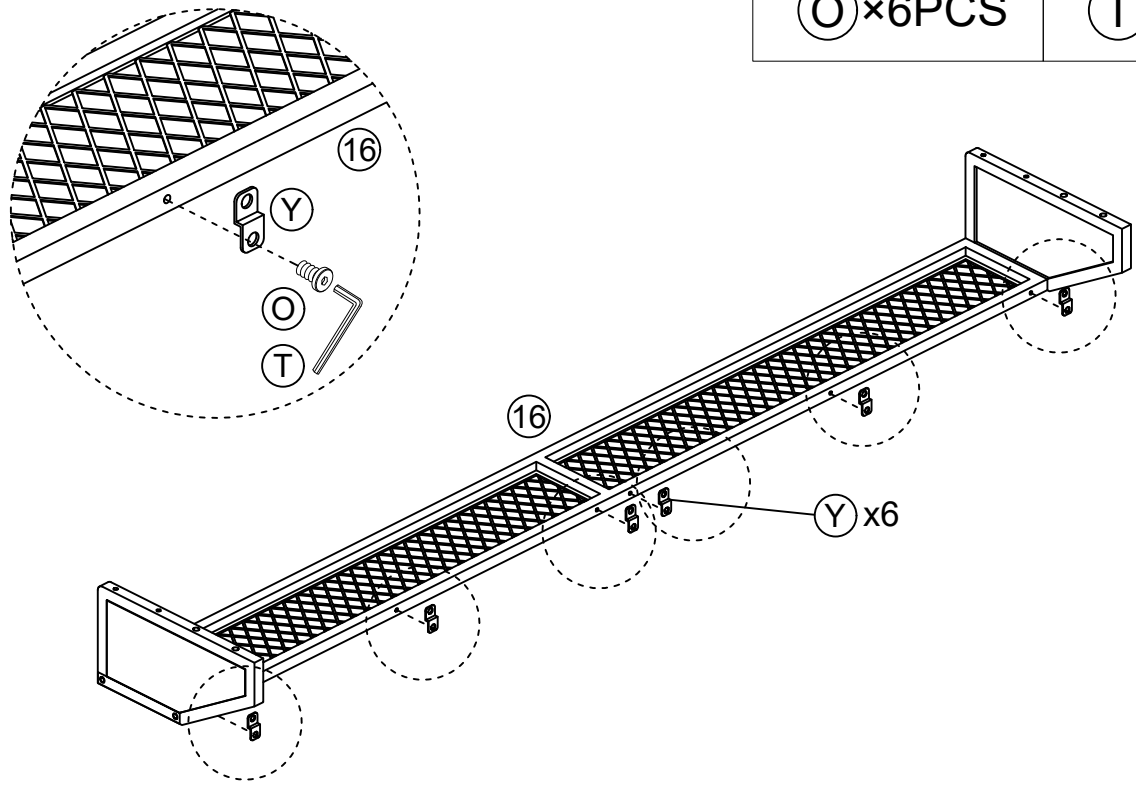

14

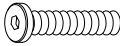
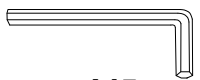
 M8*40mm	 M5
⊙×4PCS	⊕×1PC

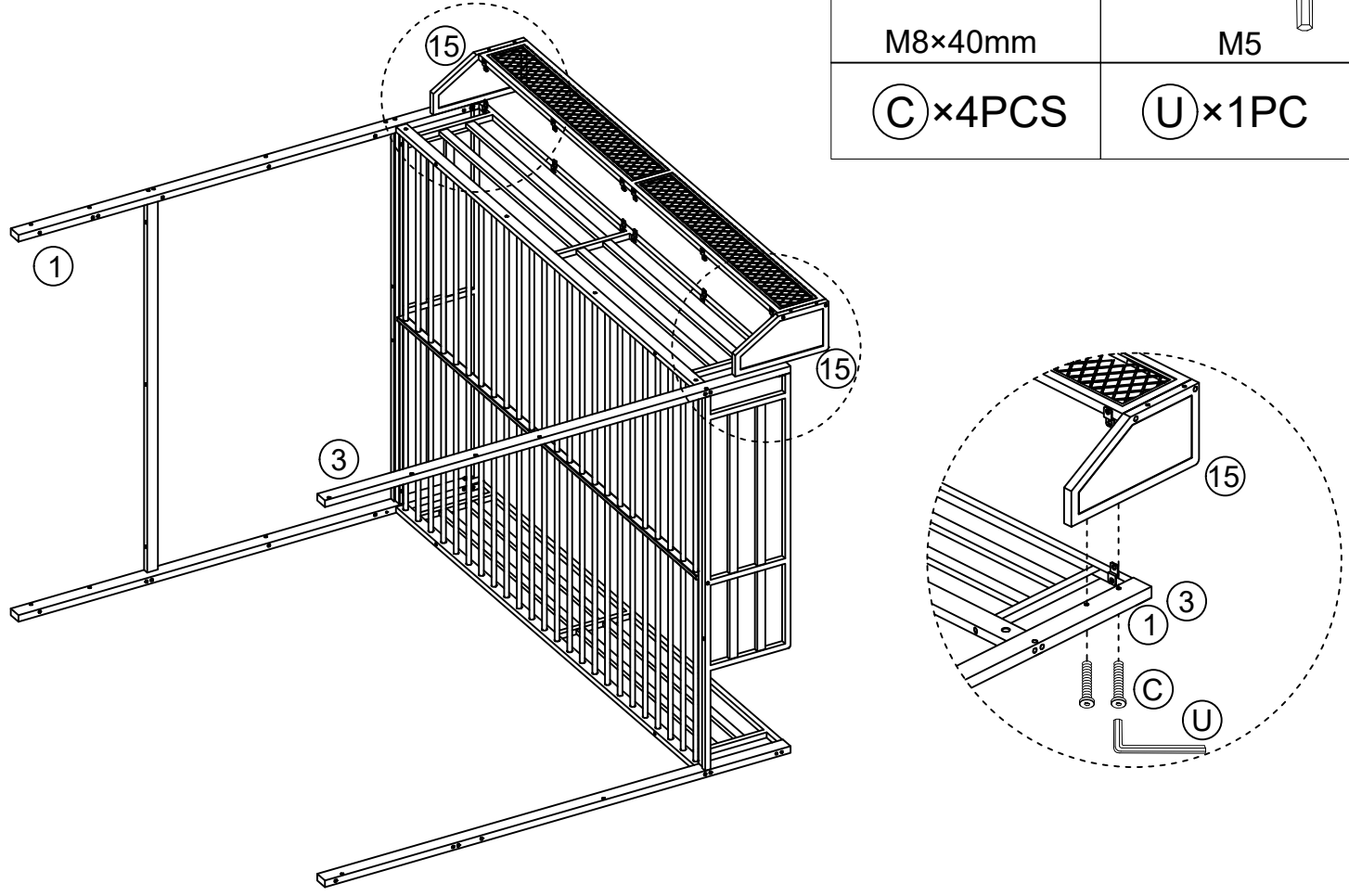

15

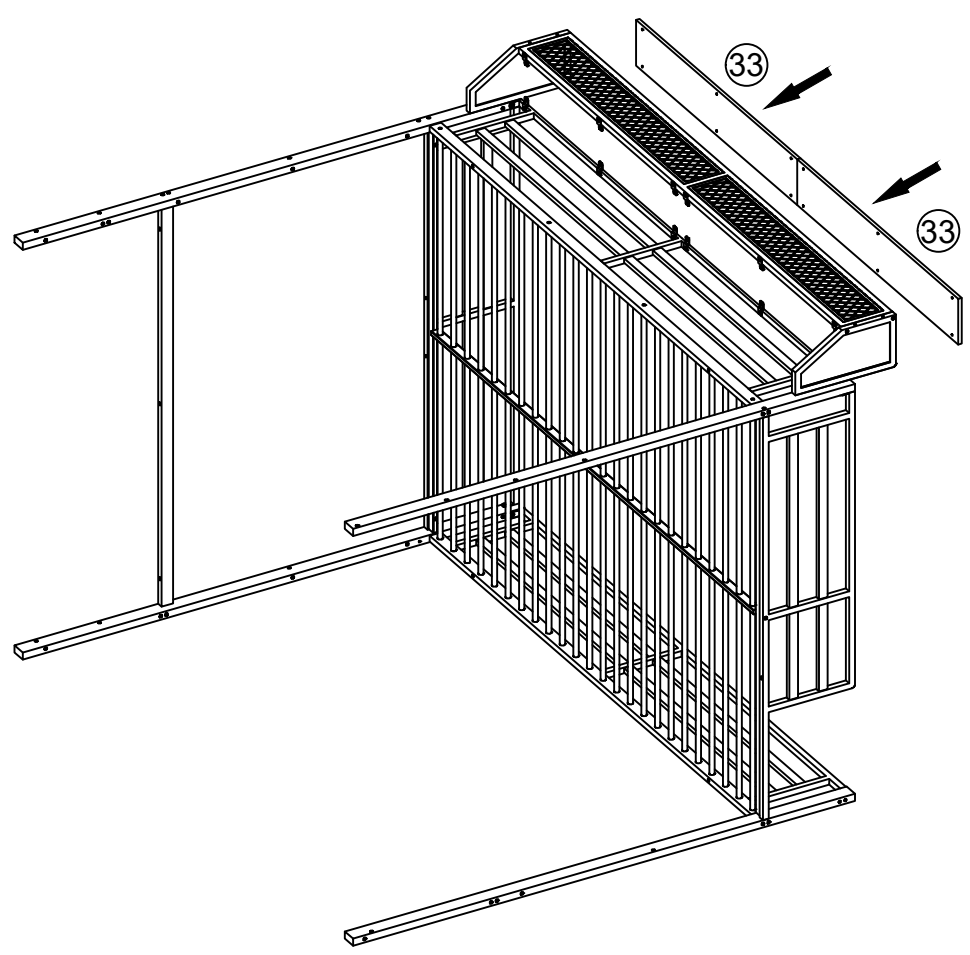

16

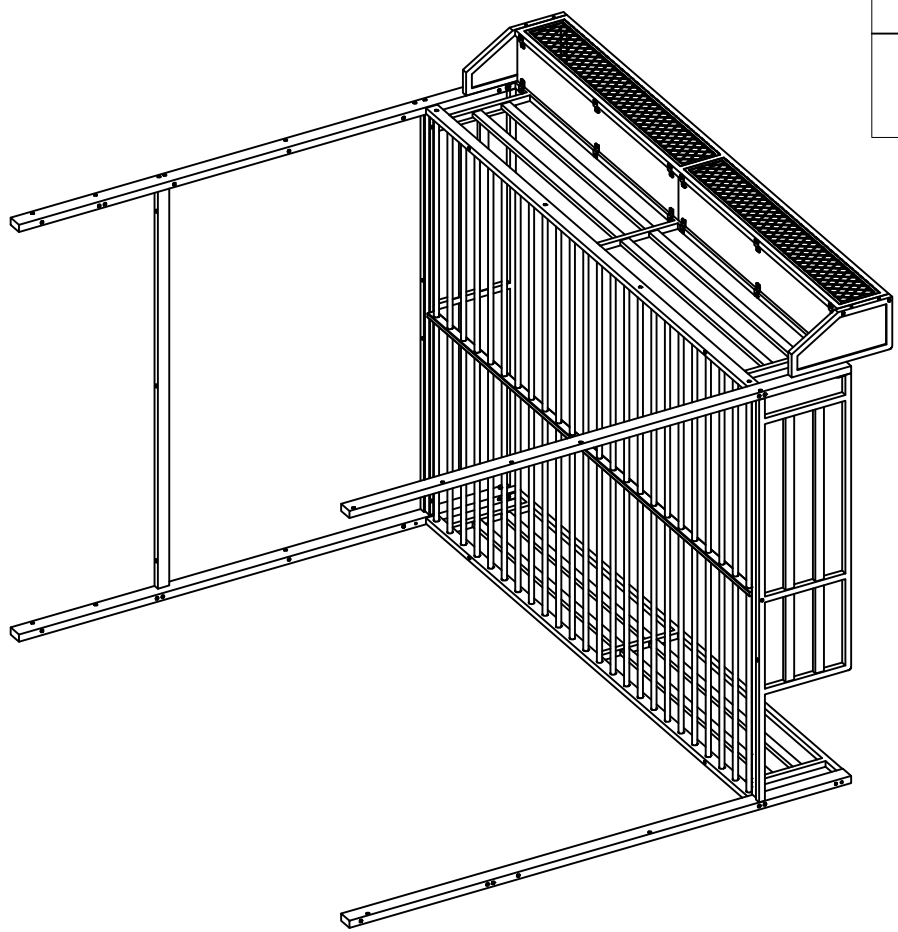

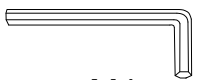
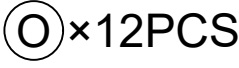
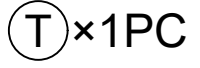
 M6*12mm	 M4
 × 12PCS	 × 1PC

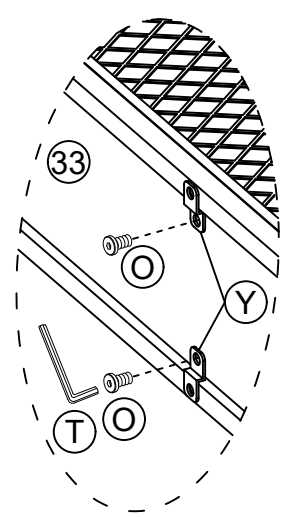

17

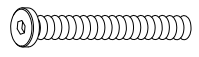
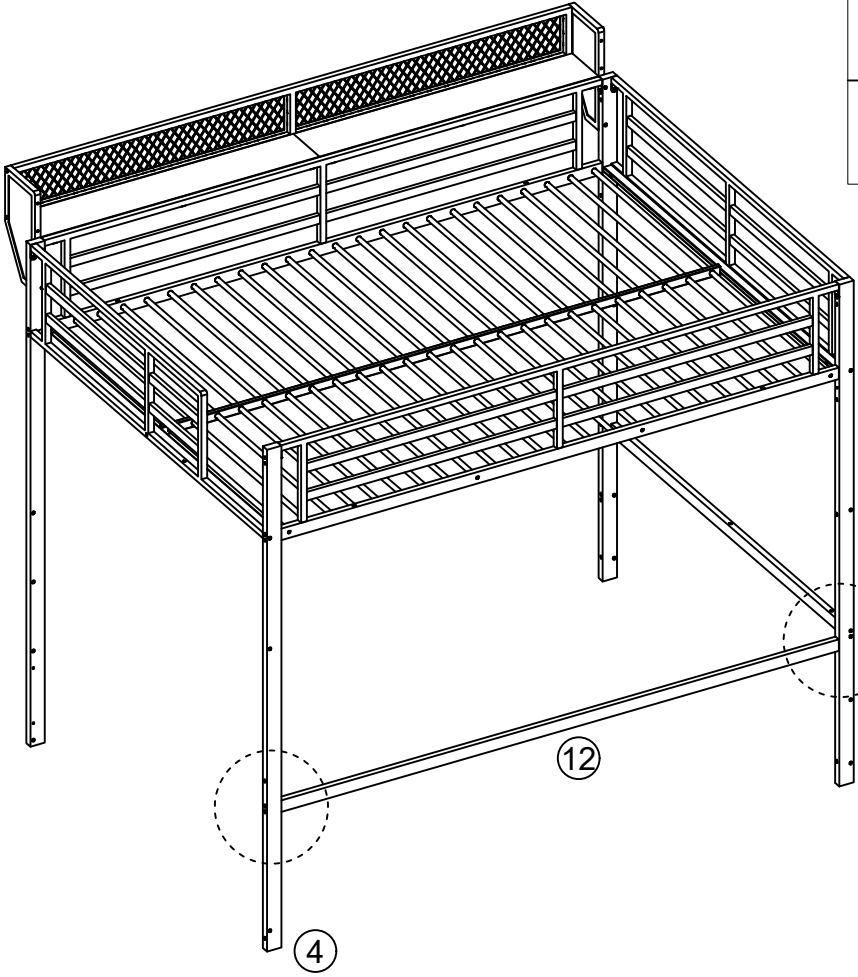

M8*70mm

(A) x4PCS



M5

(U) x1PC

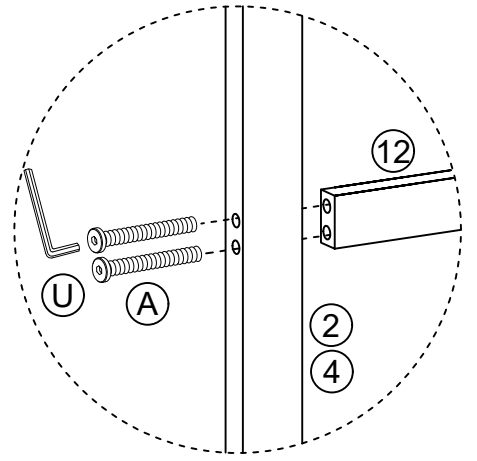

18

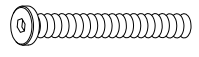
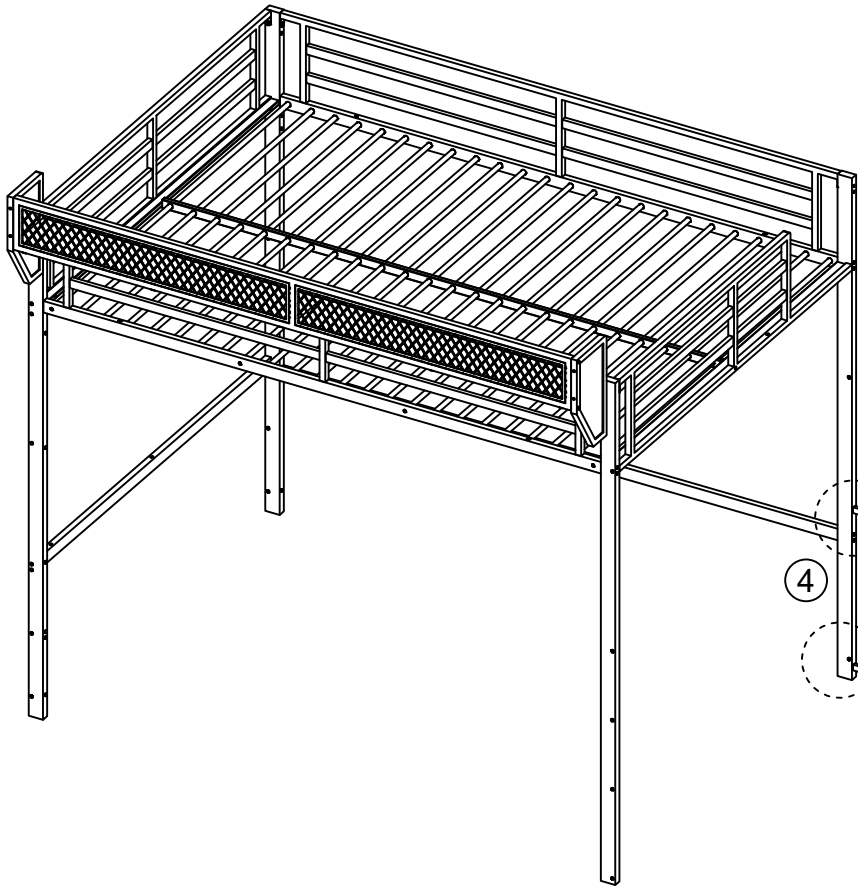

M6*70mm

(F) x4PCS



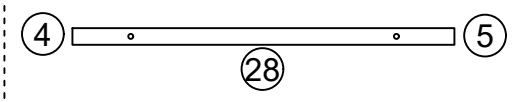
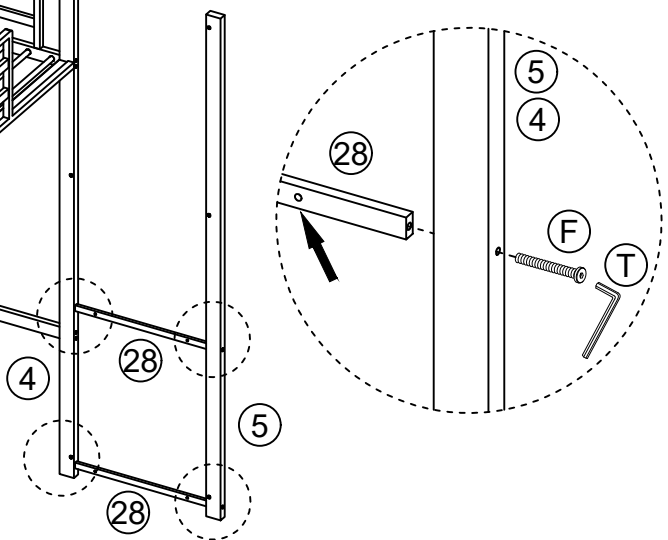

M4

(T) x1PC



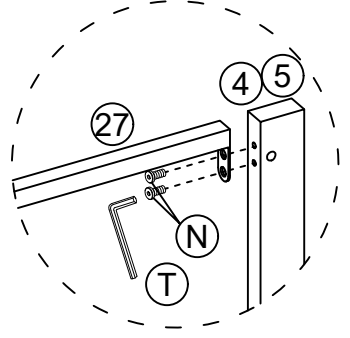
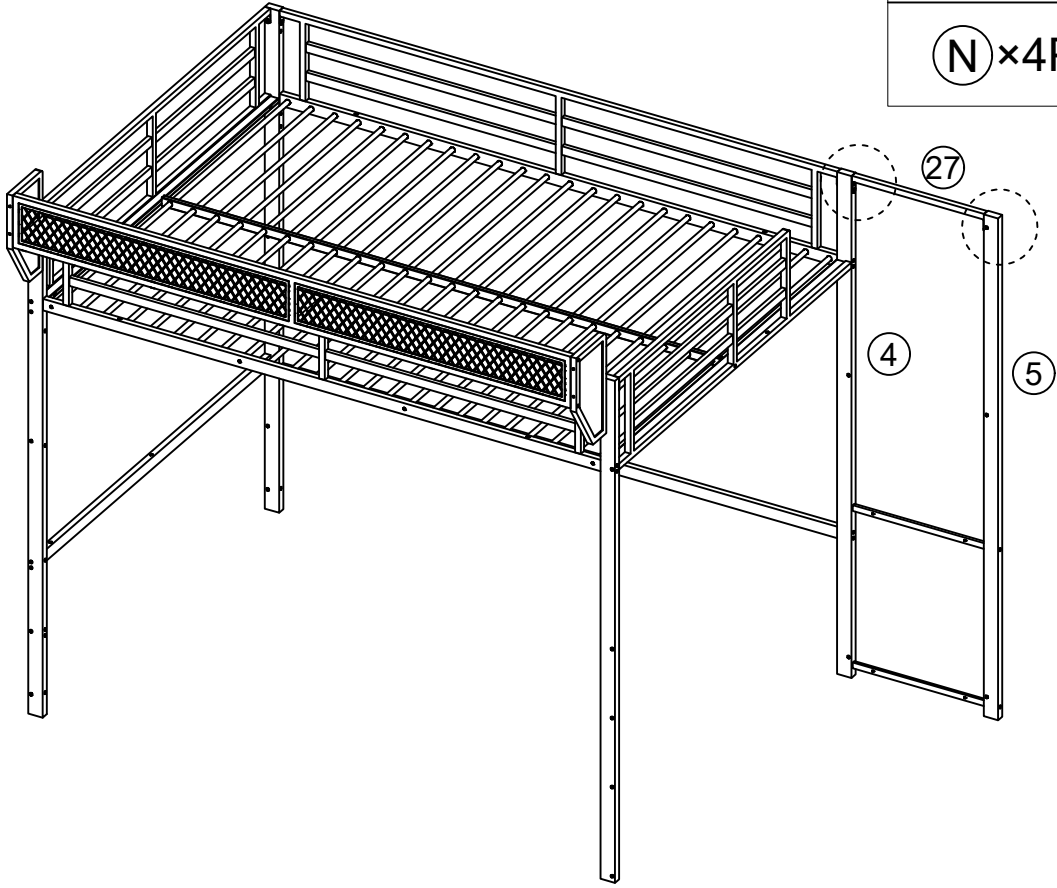

19

 M6×15mm	 M4
(N)×4PCS	(T)×1PC



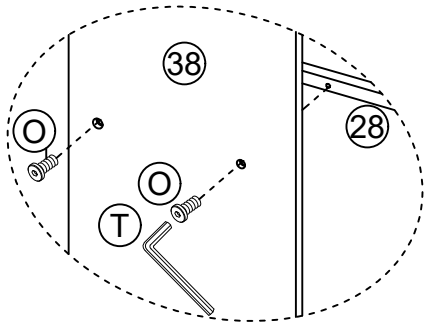
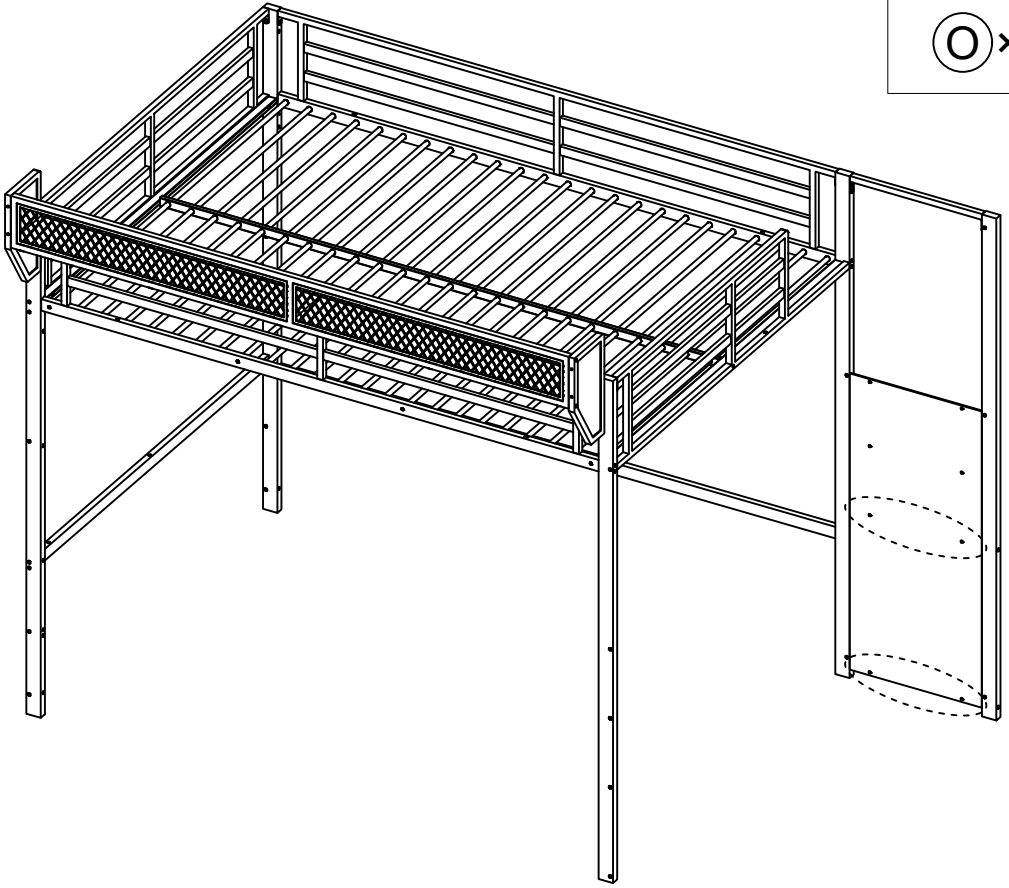

20

 M6*12mm	 M4
(O)×4PCS	(T)×1PC



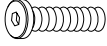

21

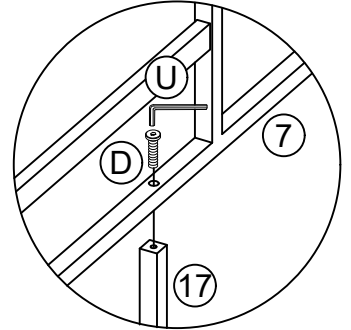
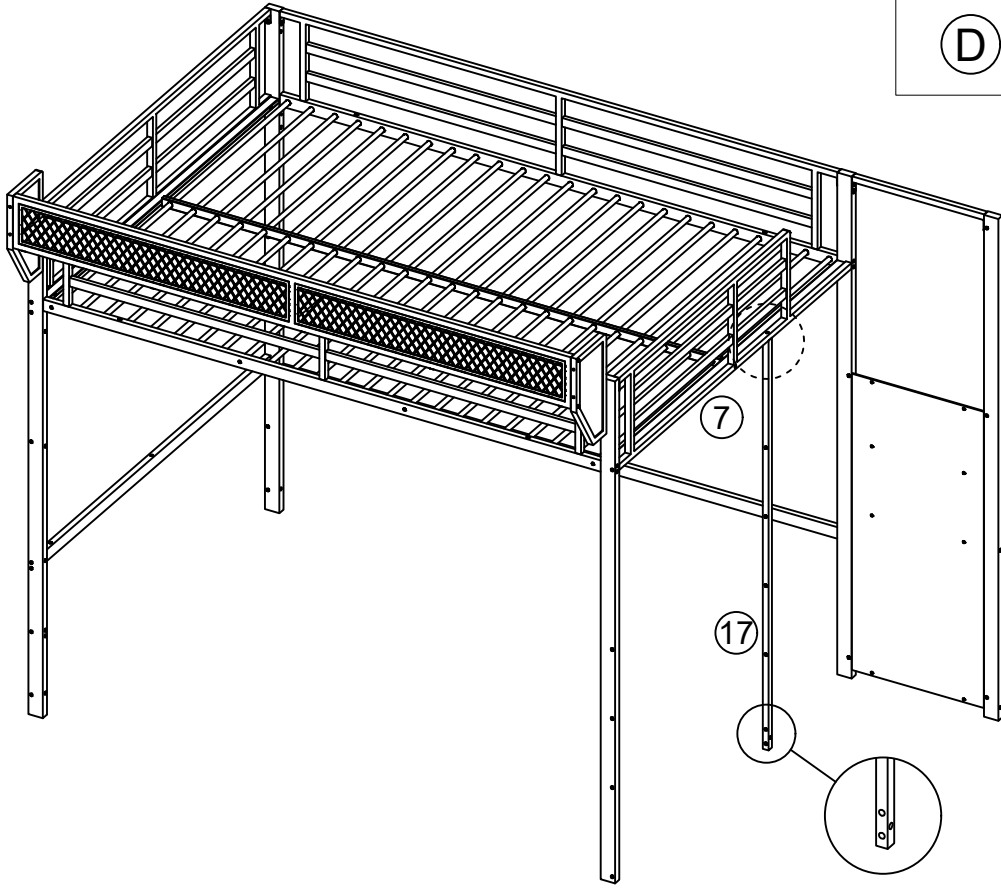
	
M8*35mm	M5
(D) × 1PC	(U) × 1PC



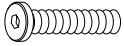
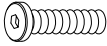

22

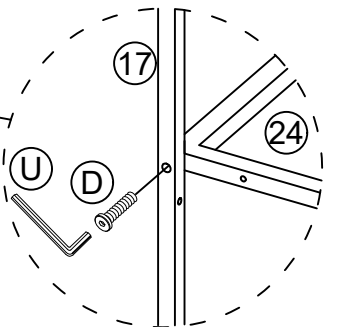
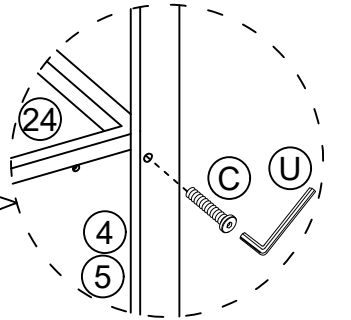
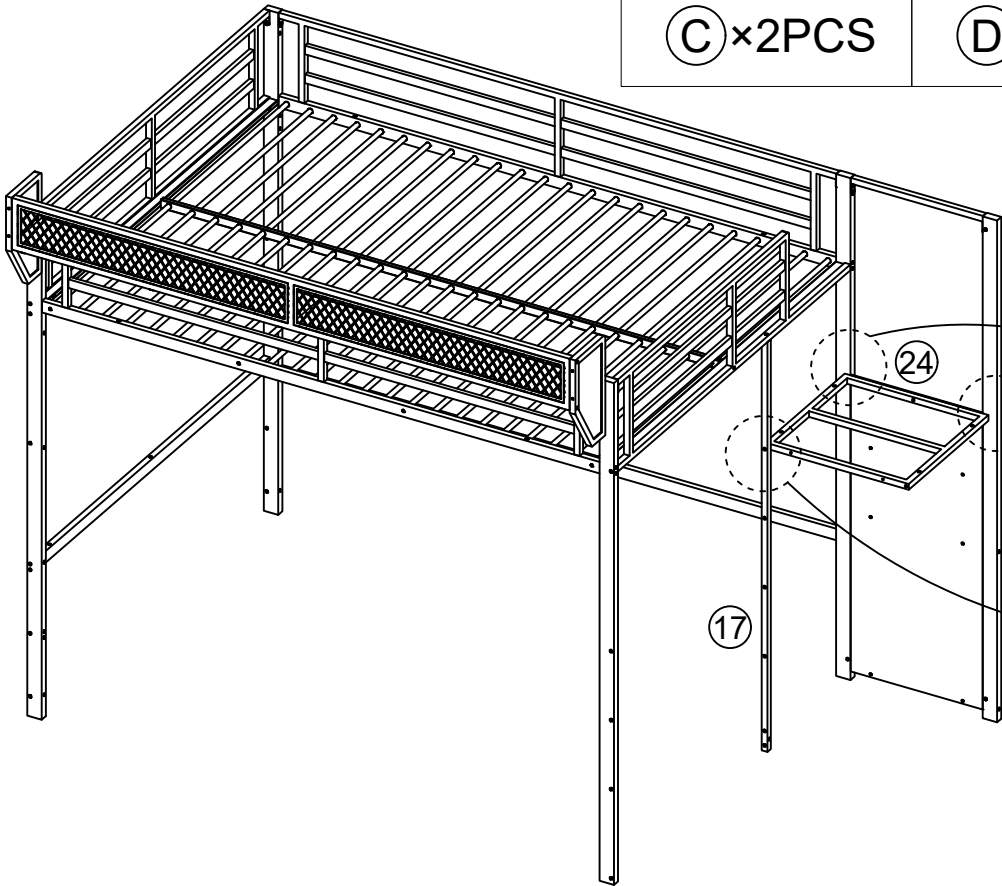
		
M8×40mm	M8×35mm	M5
(C) × 2PCS	(D) × 1PC	(U) × 1PC



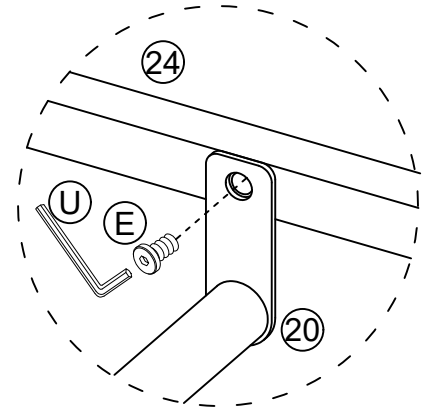
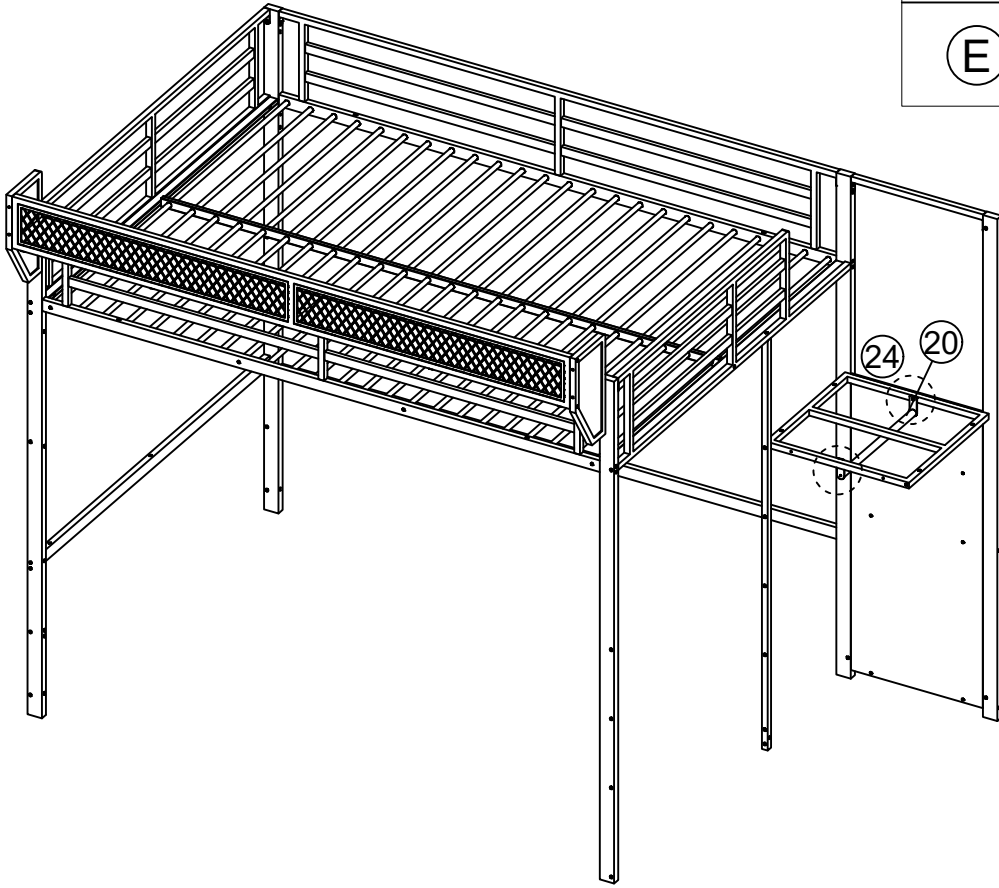

23

 M8×20mm	 M5
ⓔ×2PCS	Ⓤ×1PC



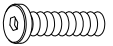

24

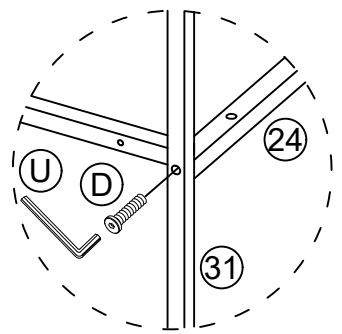
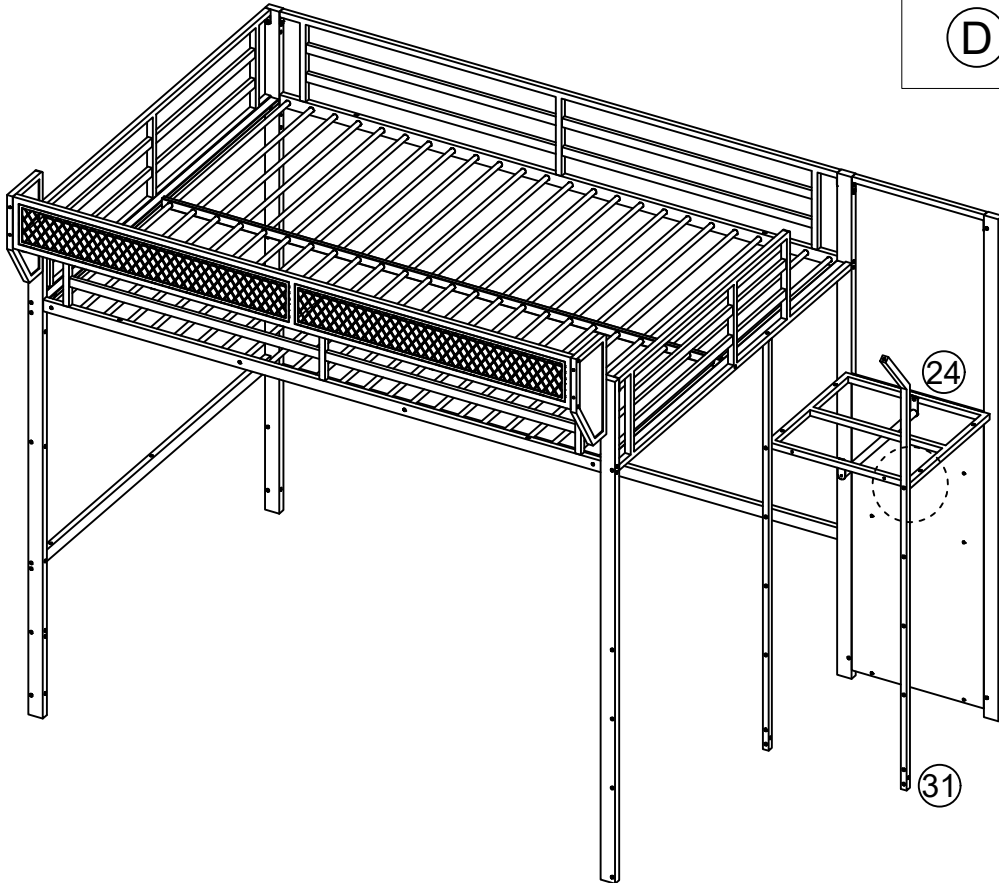
 M8×35mm	 M5
ⓓ×1PC	Ⓤ×1PC



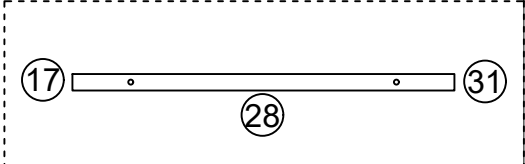
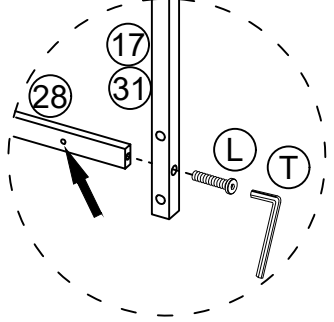
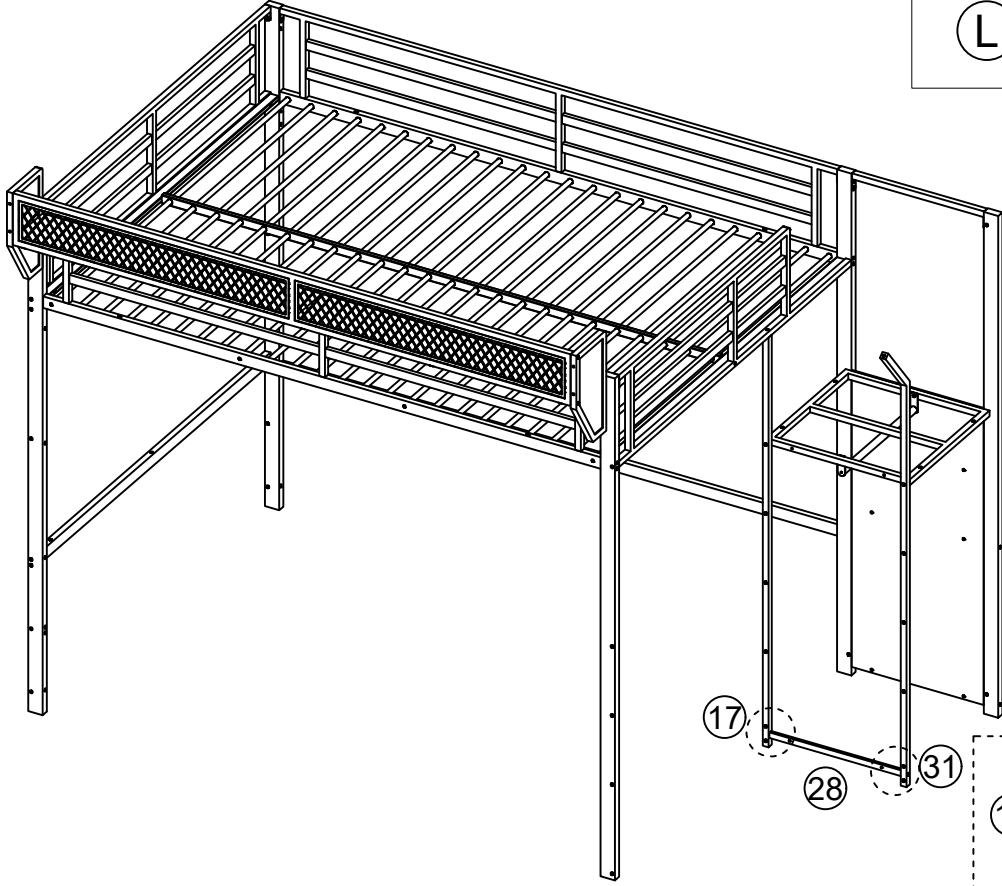

25

 M6*40mm	 M4
(L) × 2PCS	(T) × 1PC



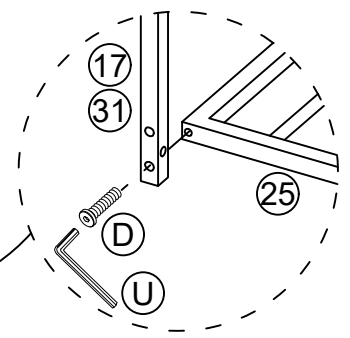
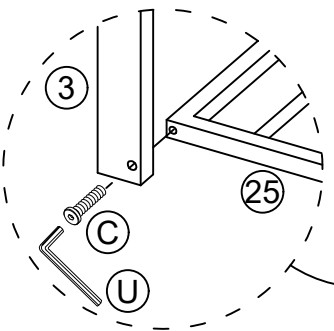
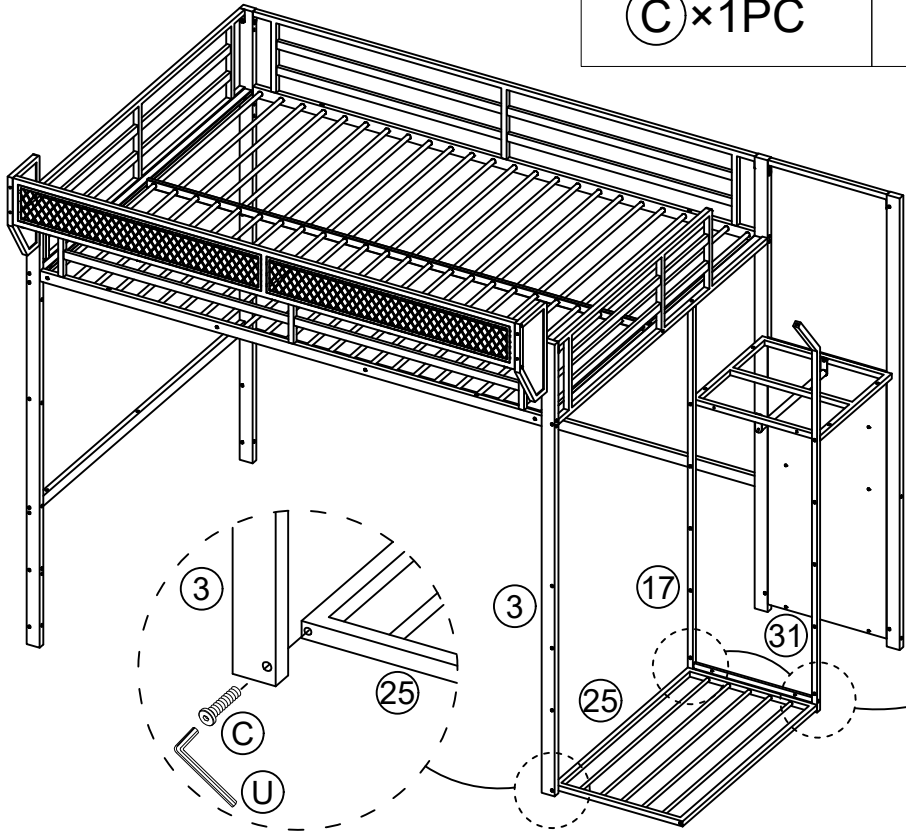

26

 M8×40mm	 M8×35mm	 M5
(C) × 1PC	(D) × 2PCS	(U) × 1PC



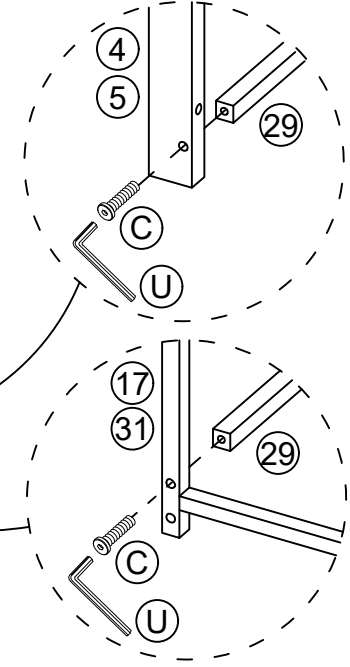
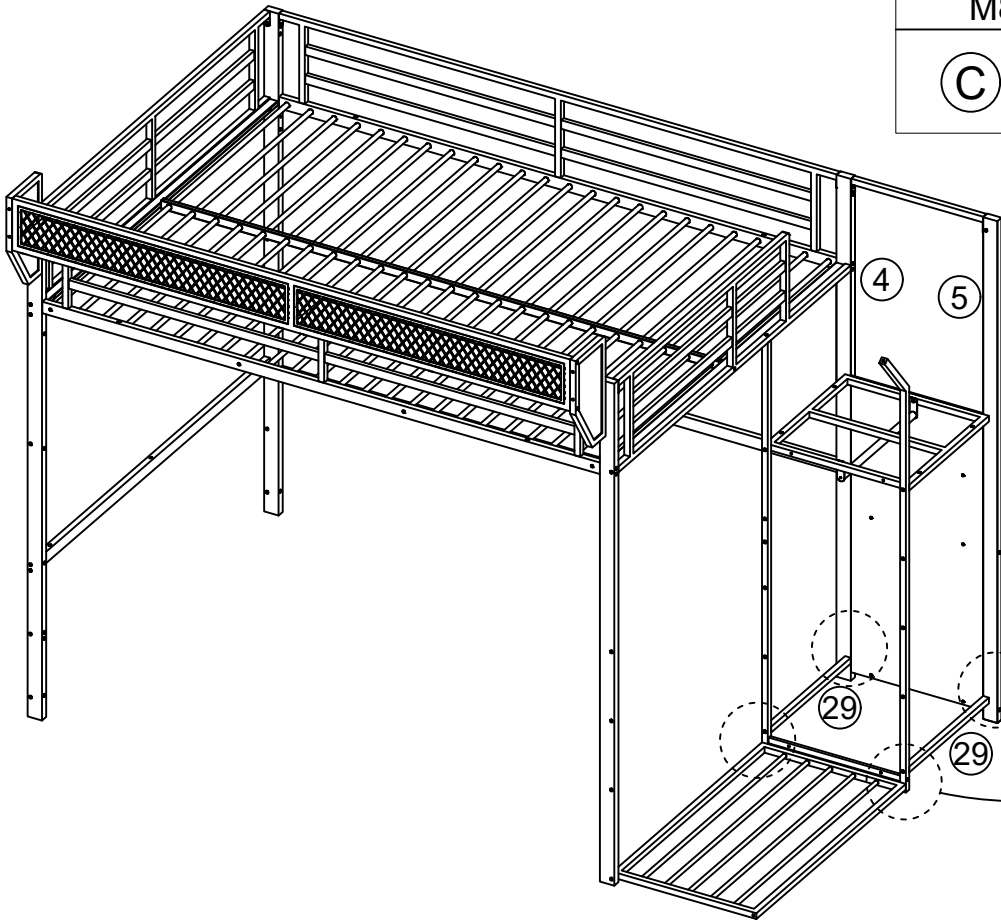

27

	
M8×40mm	M5
ⓐ×4PCS	Ⓤ×1PC





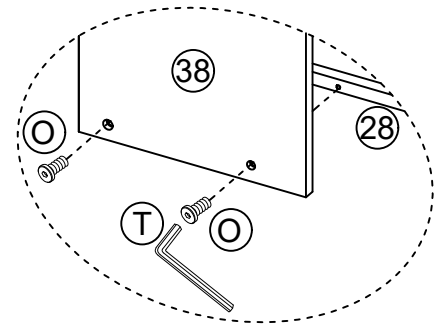
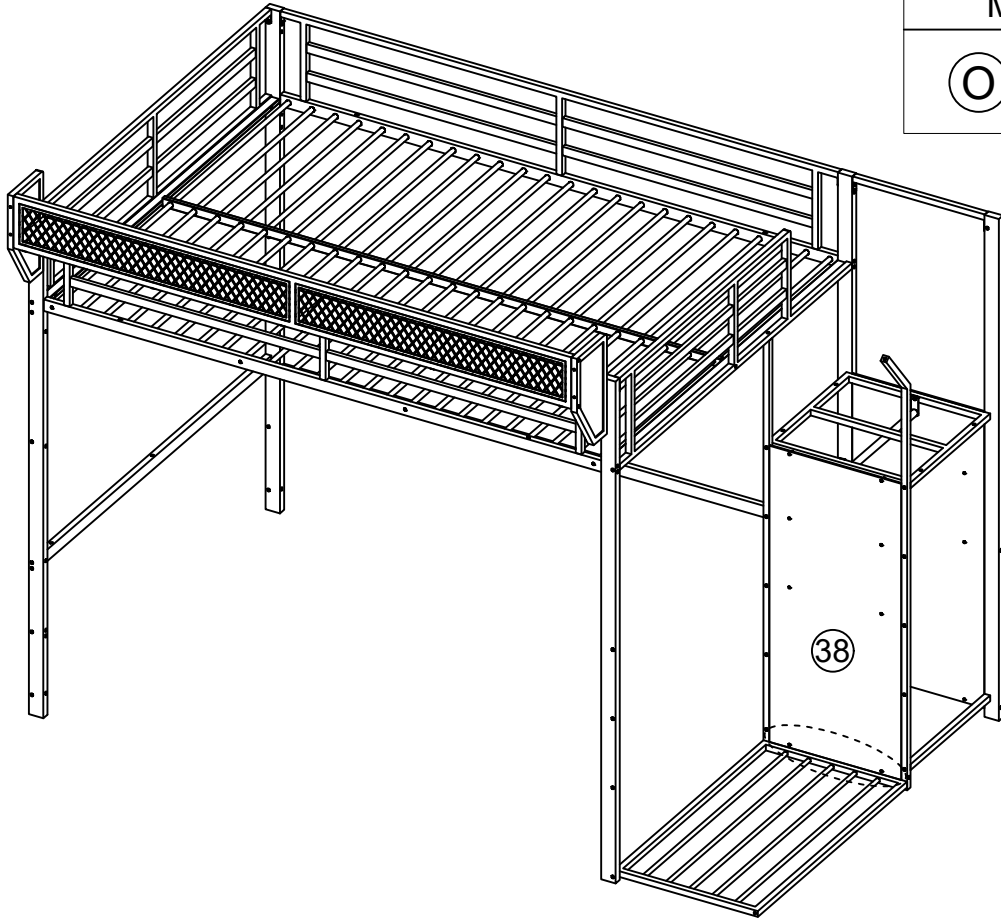

28

	
M6*12mm	M4
ⓐ×2PCS	Ⓣ×1PC

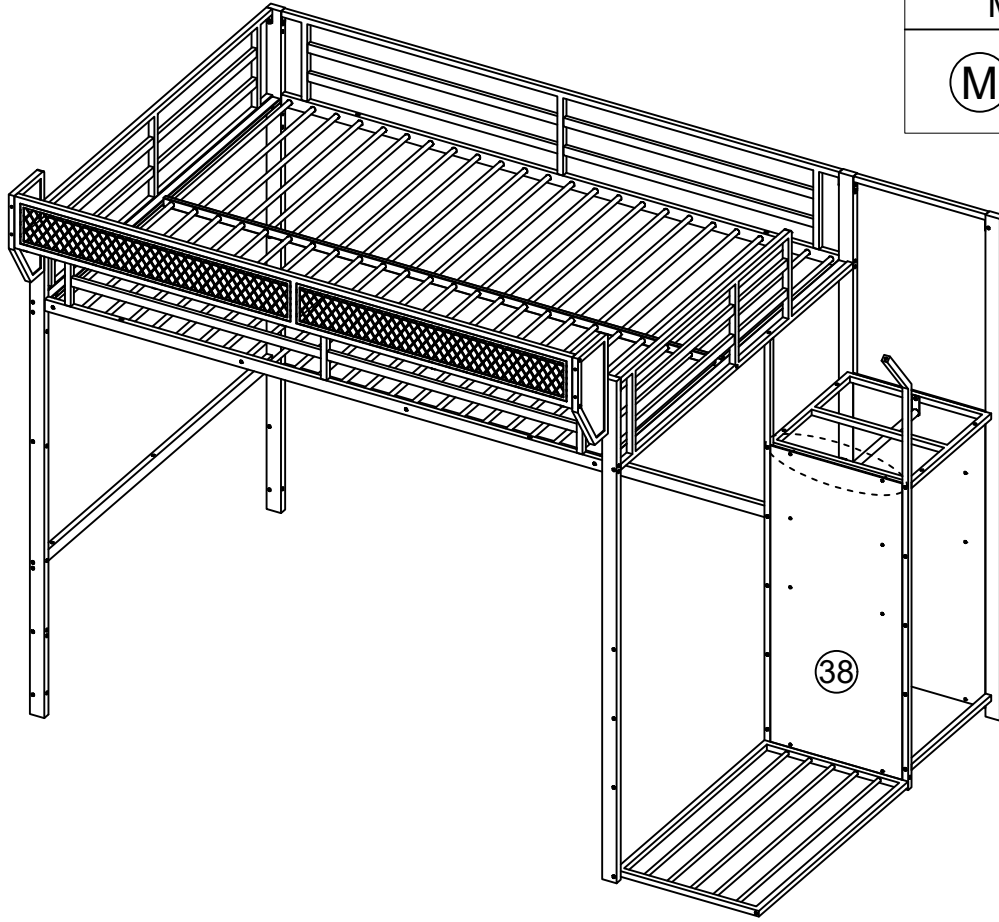

29



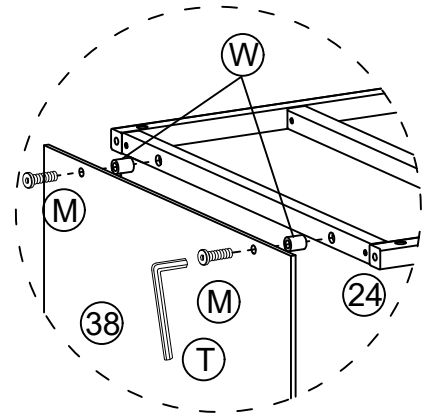

 M6*30mm	 M4
(M) × 2PCS	(T) × 1PC
	
	(W) × 2PCS

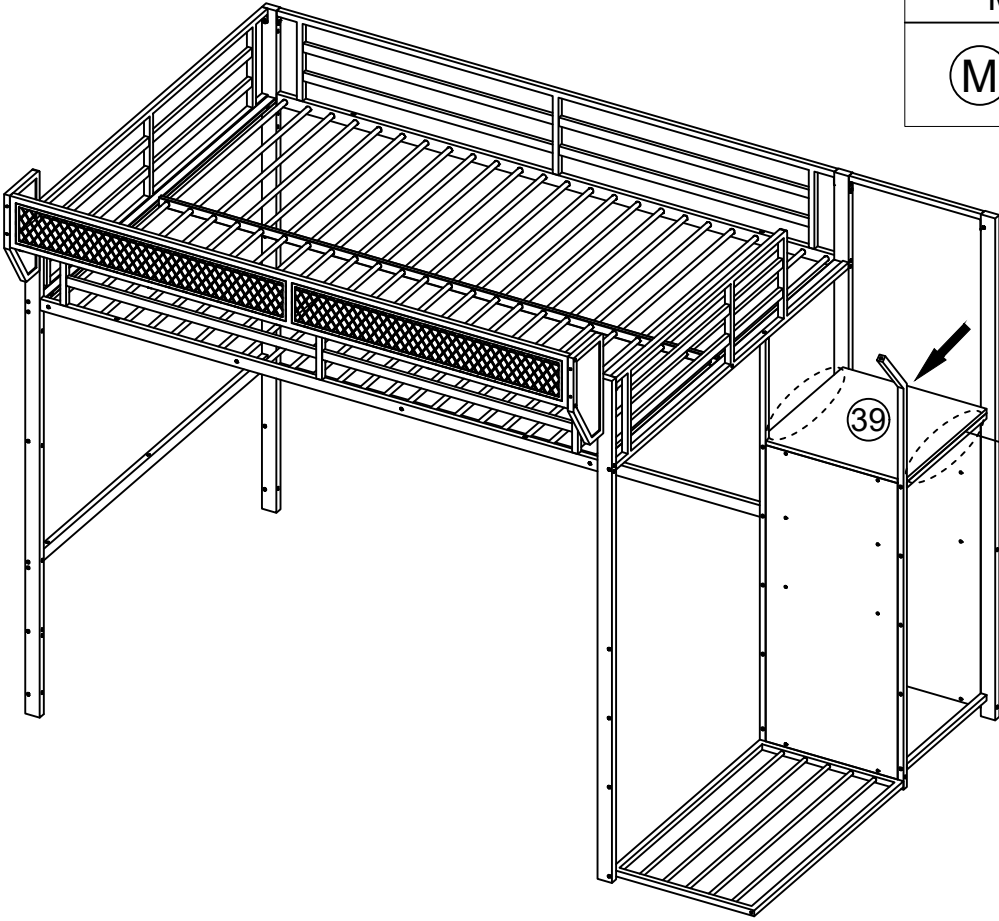

30



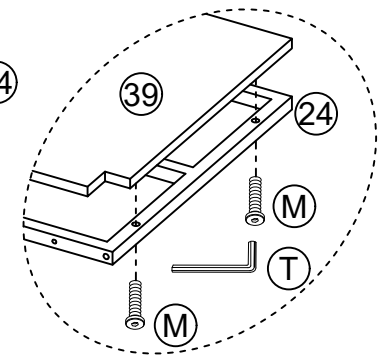
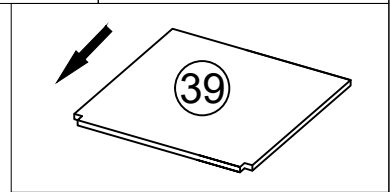

 M6*30mm	 M4
(M) × 4PCS	(T) × 1PC

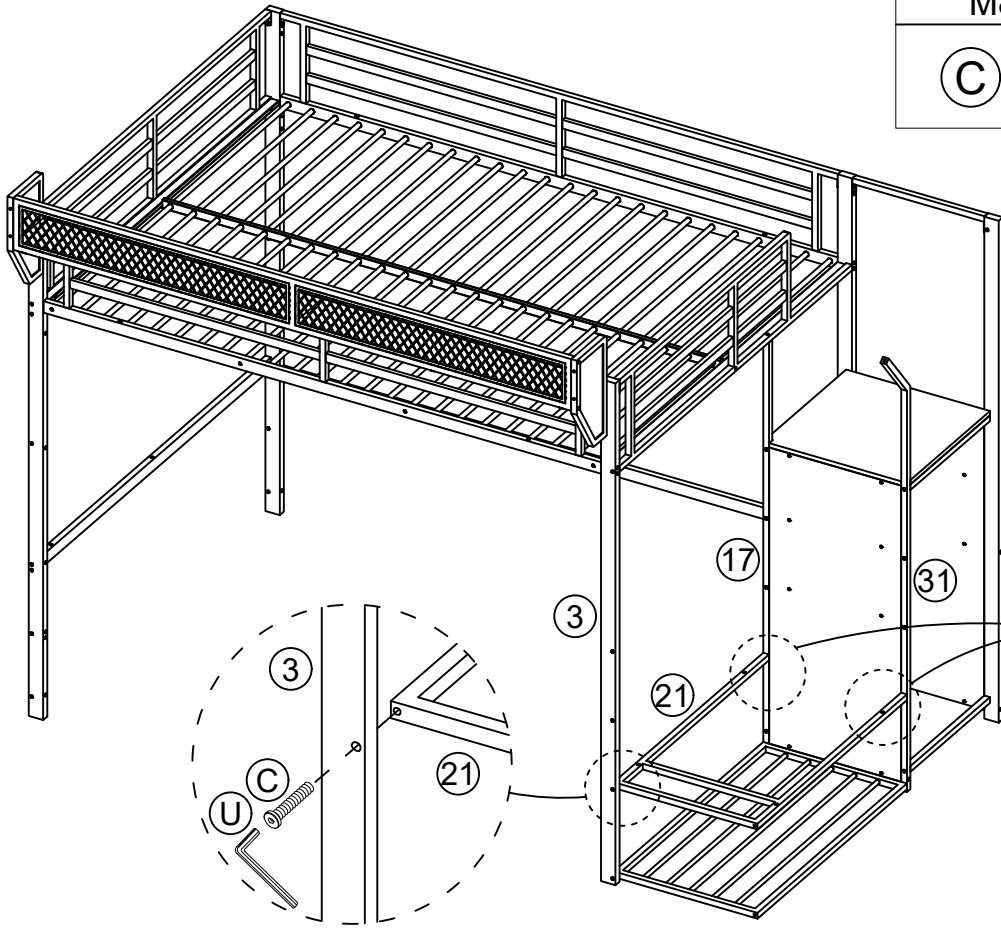

31

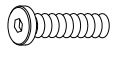

	
M8×40mm	M8×35mm
(C) ×1PC	(D) ×2PCS
	
	M5
	(U) ×1PC

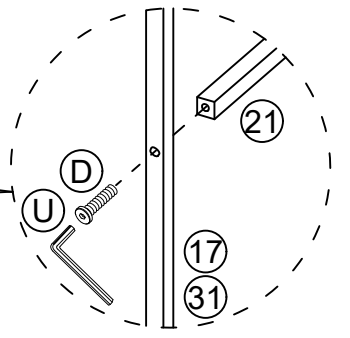
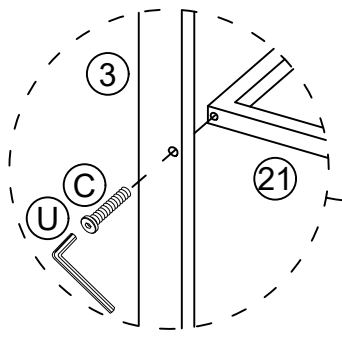

32

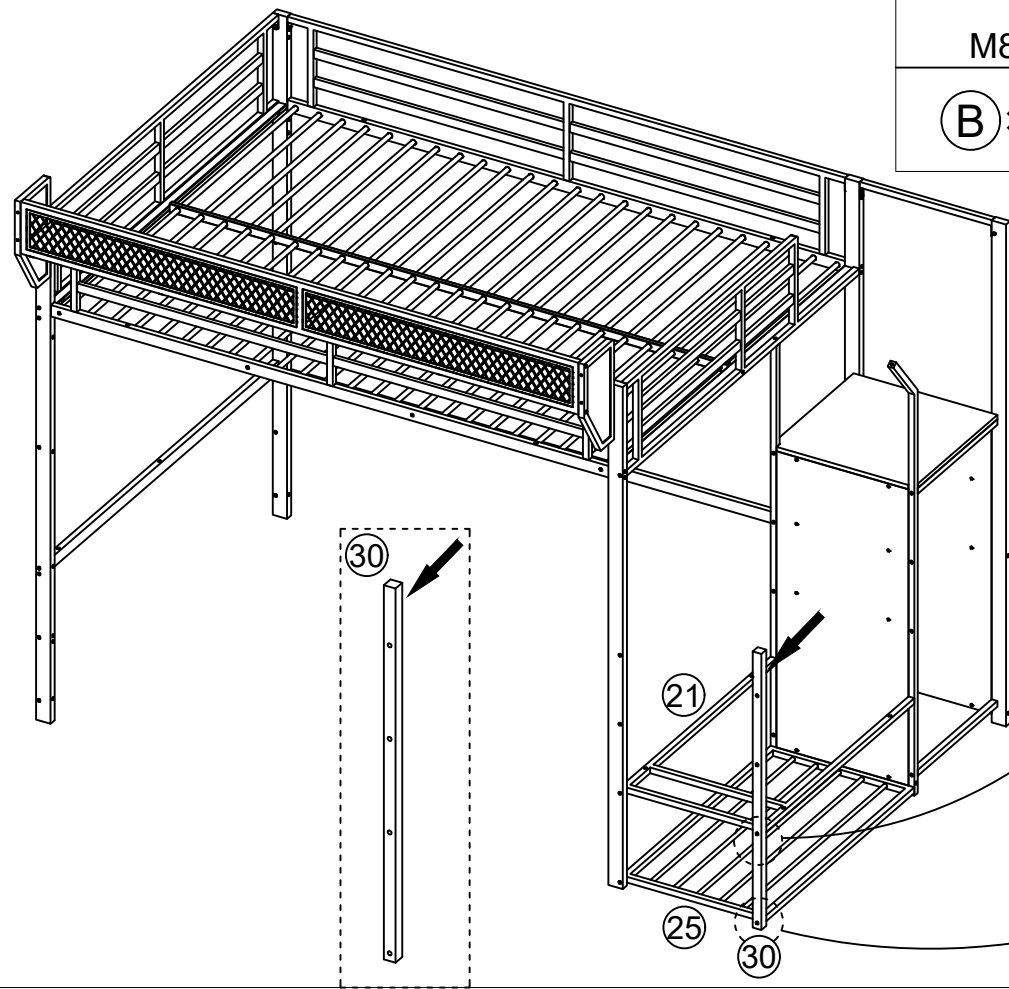

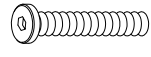
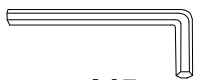

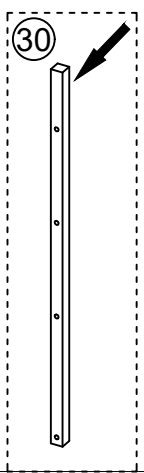
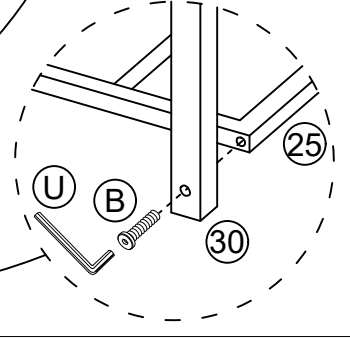
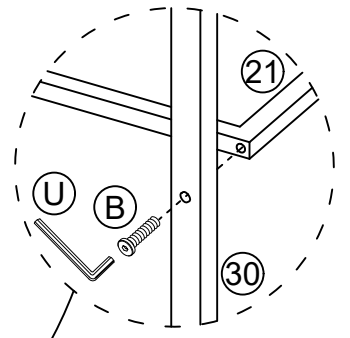
	
M8×50mm	M5
(B) ×2PCS	(U) ×1PC

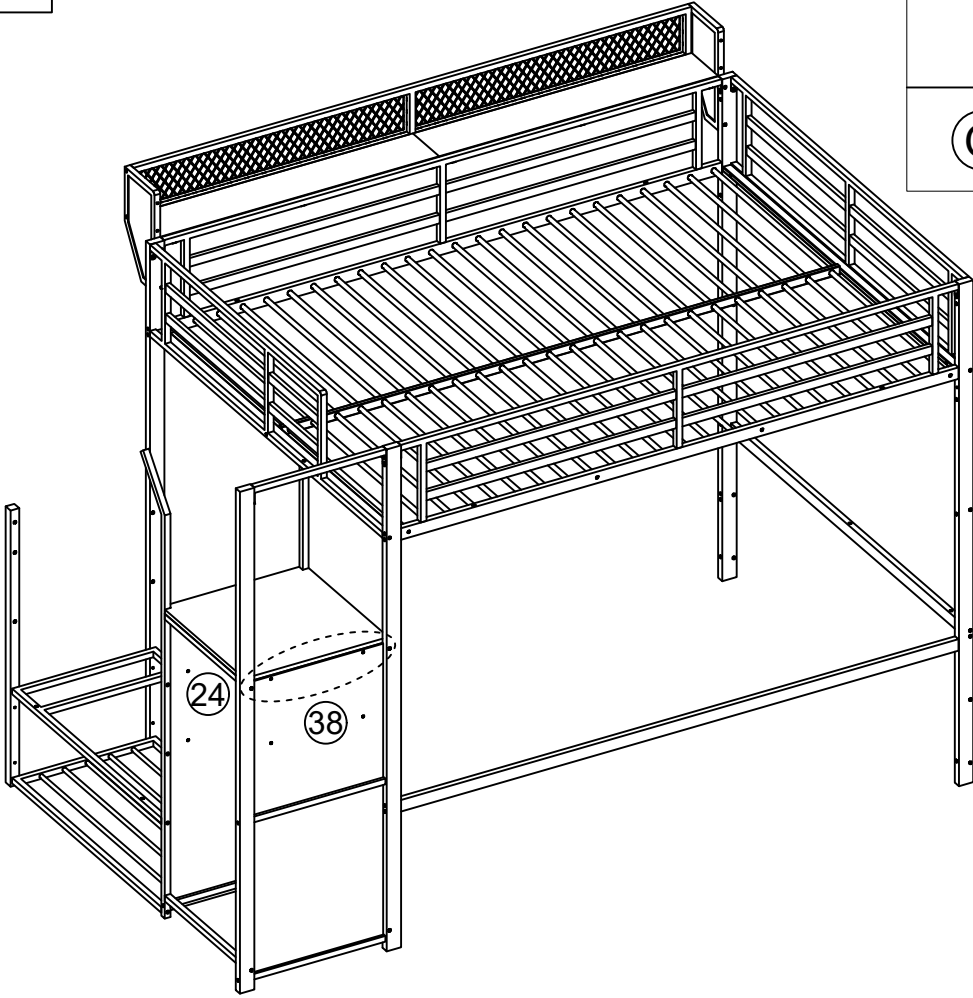

33



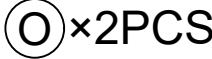
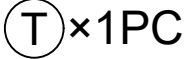

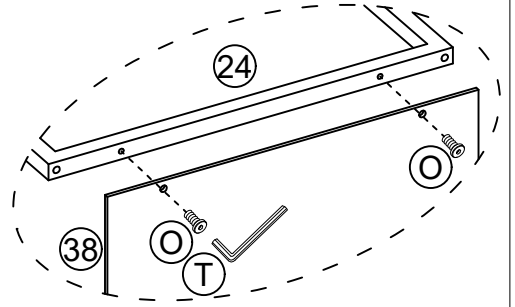
 M6*12mm	 M4
 × 2PCS	 × 1PC

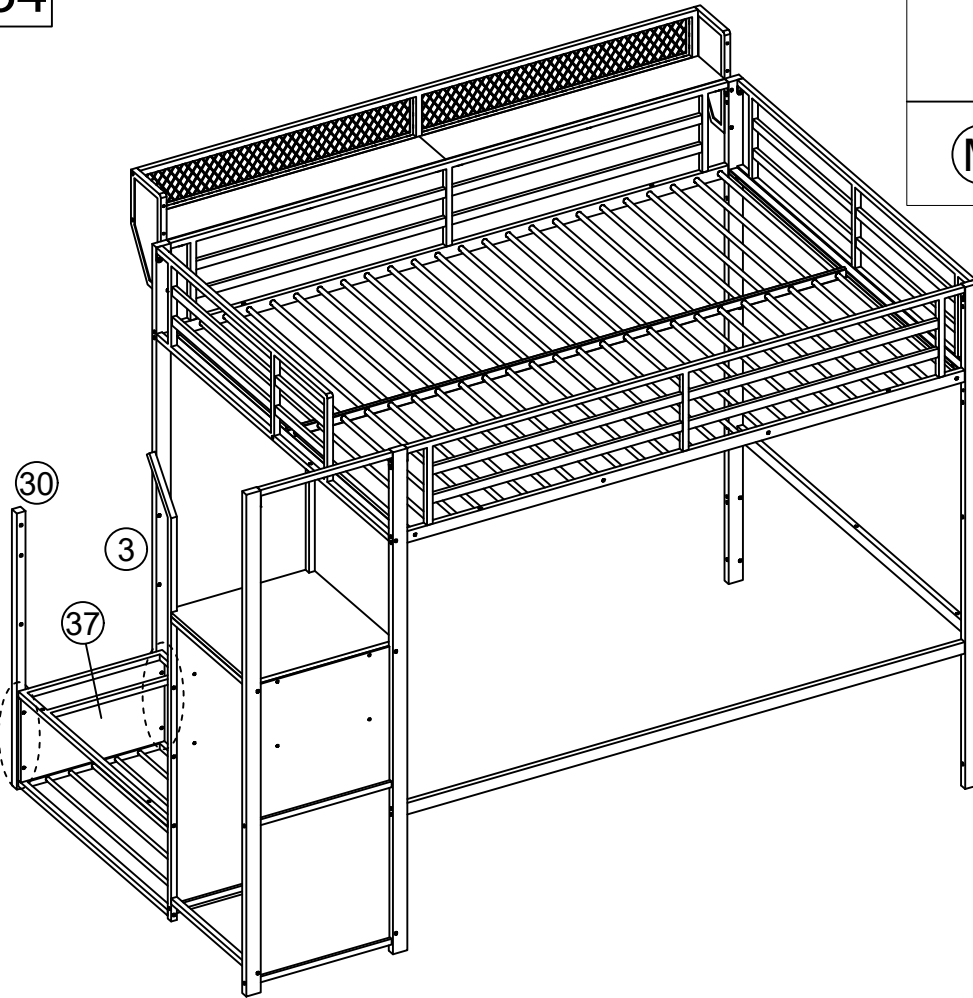

34

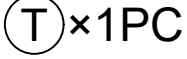

 M6*30mm	 M4
 × 4PCS	 × 1PC

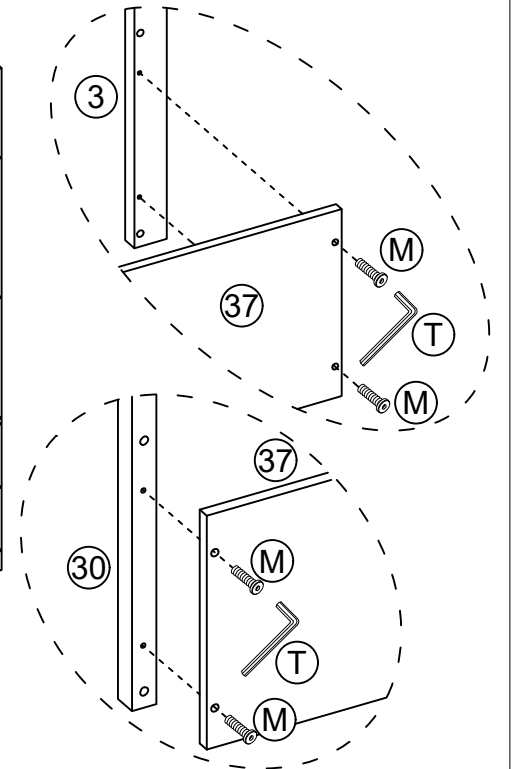

35

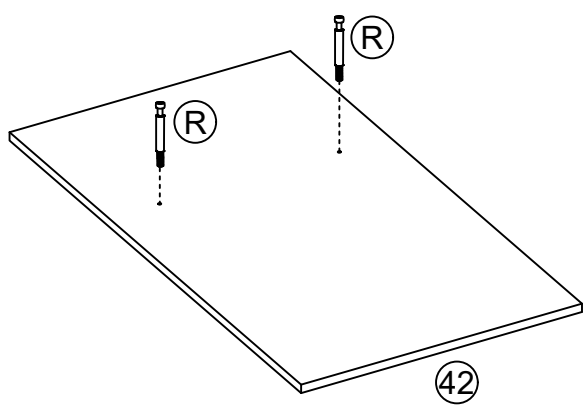
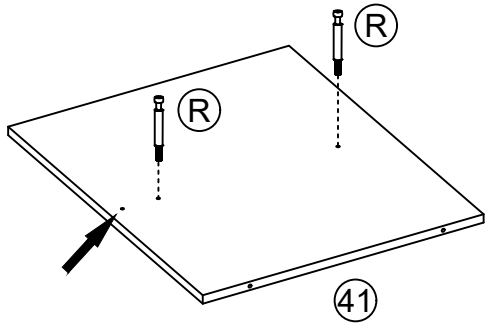

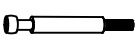
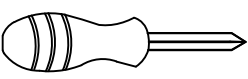
	
(R) x 4PCS	(V) x 1PC

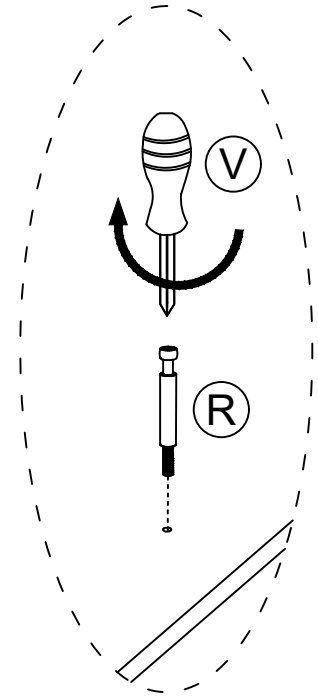

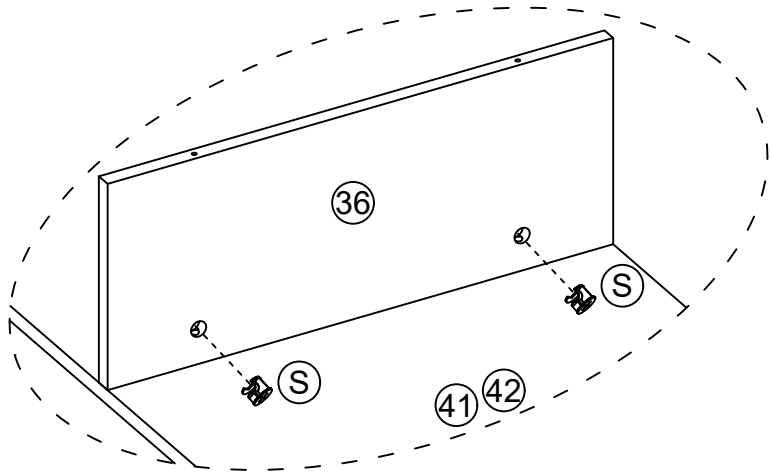

36

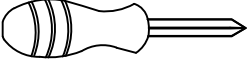

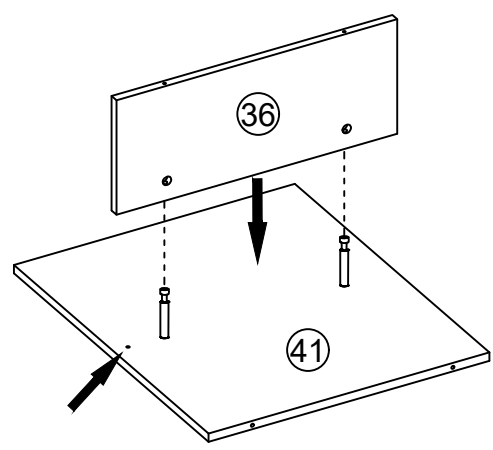
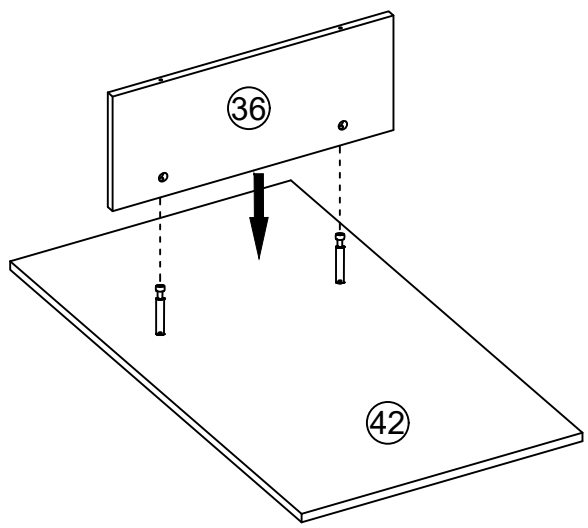
	
(S) x 4PCS	(V) x 1PC





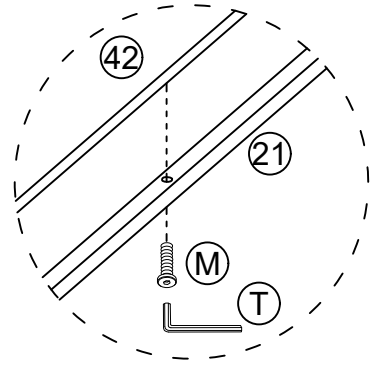
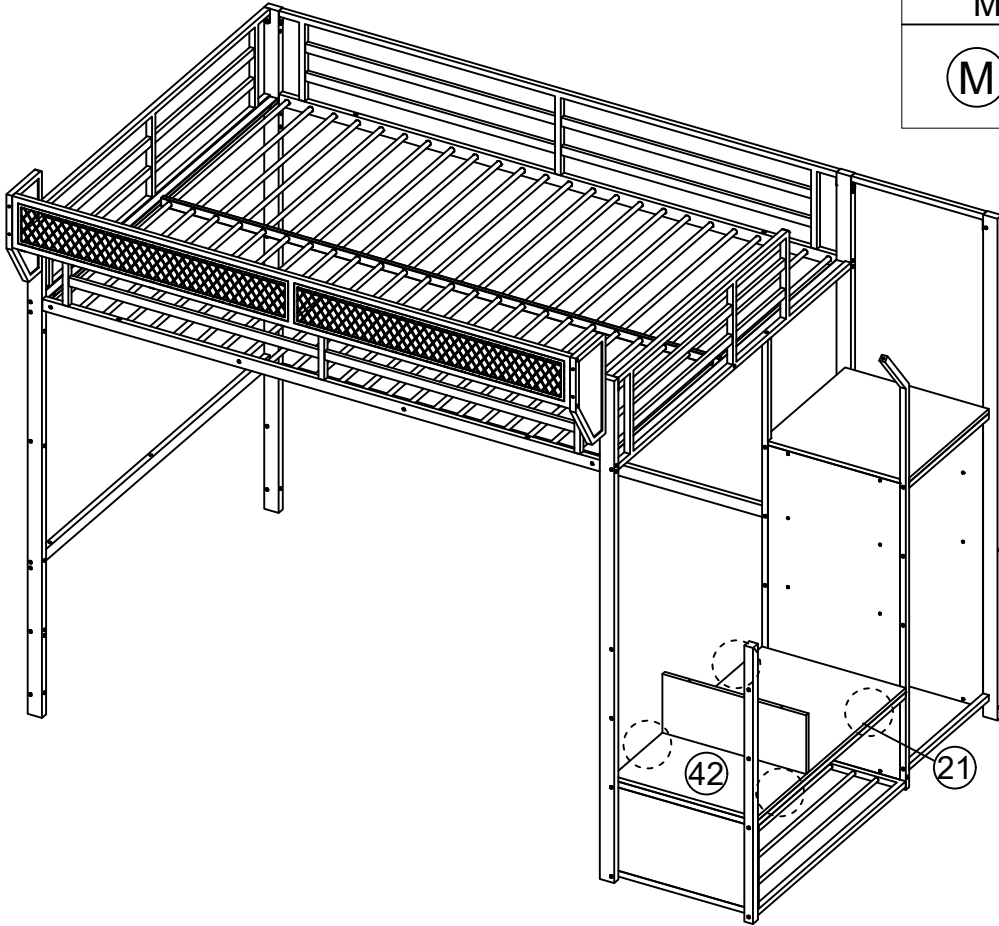

37

	
M6*30mm	M4
(M) × 4PCS	(T) × 1PC

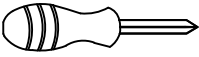

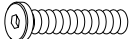
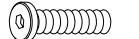

38

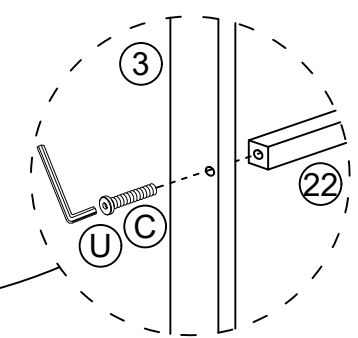
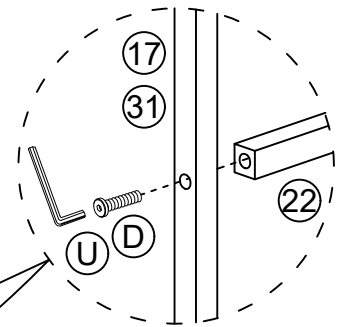
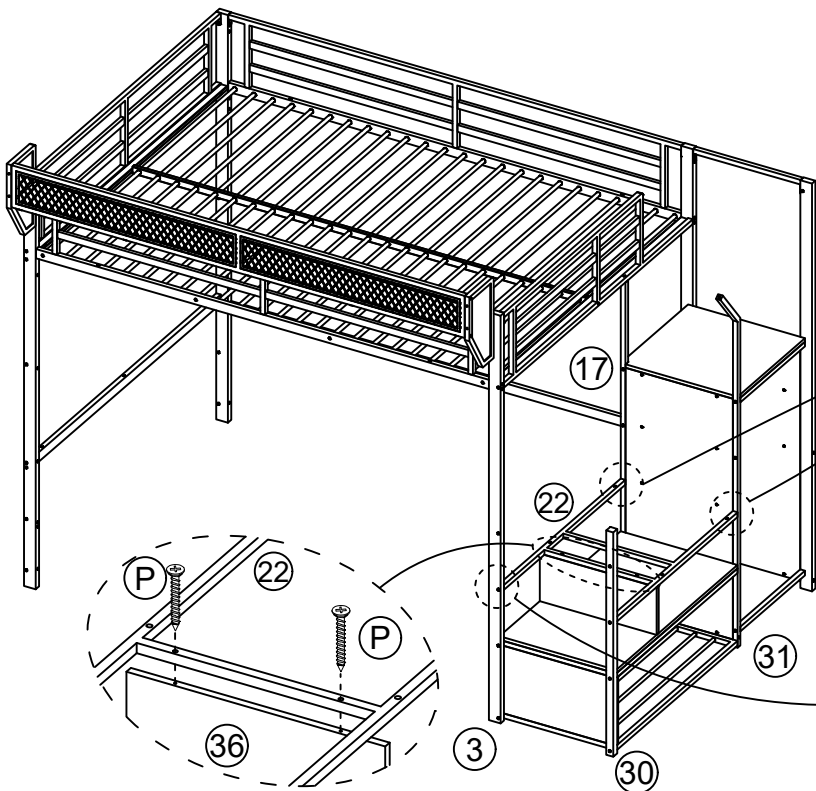
				
	M5×40mm	M8×40mm	M8×35mm	M5
(V) × 1PC	(P) × 2PCS	(C) × 1PC	(D) × 2PCS	(U) × 1PC



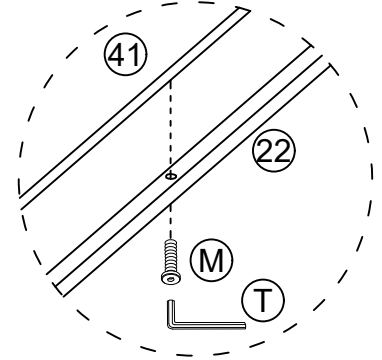
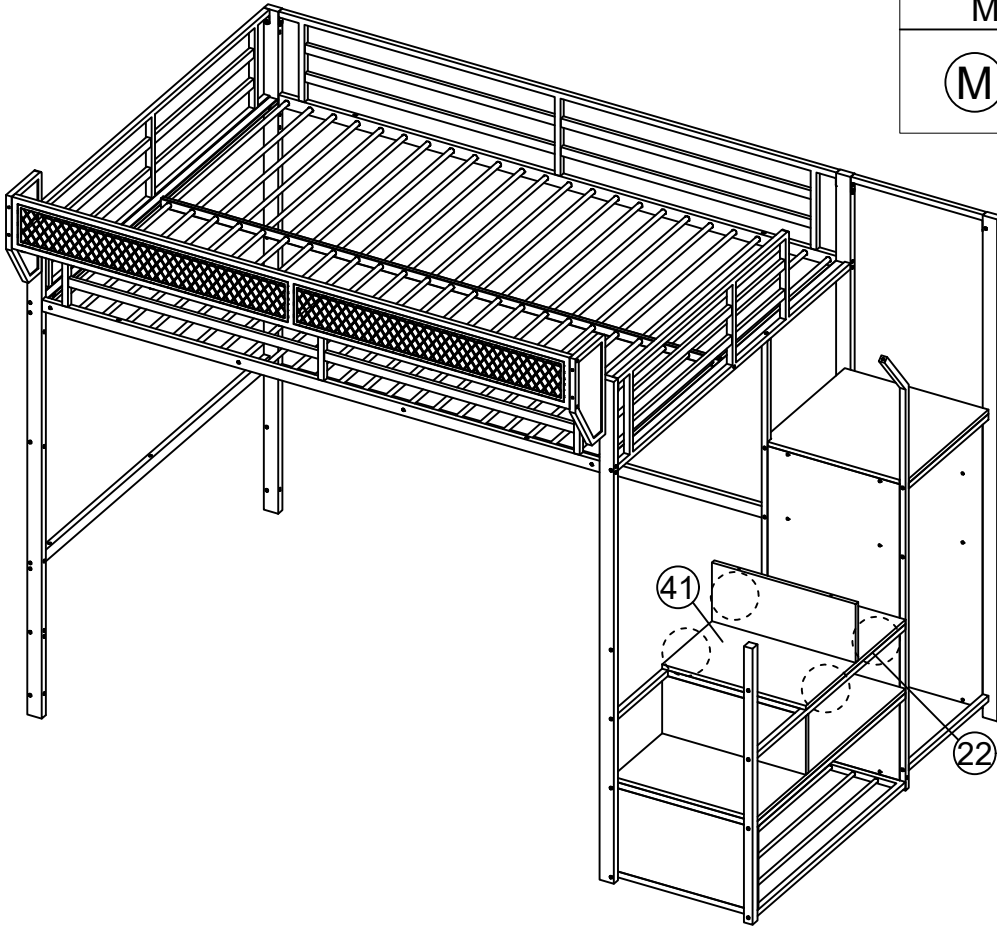

39

	
M6*30mm	M4
(M) × 4PCS	(T) × 1PC



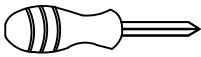

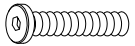
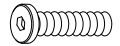
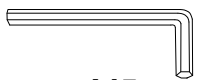
40

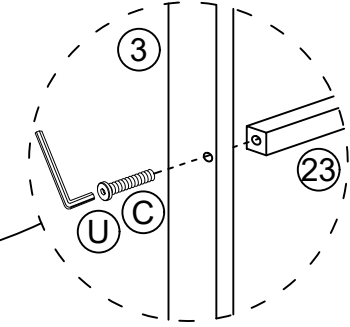
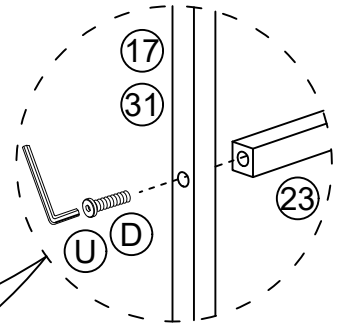
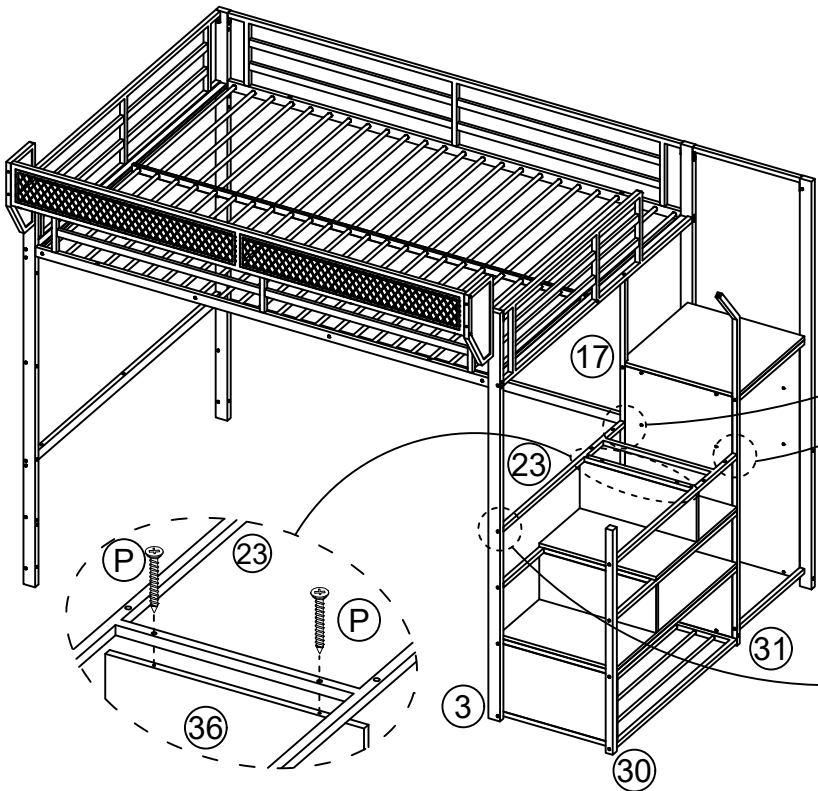
				
	M5×40mm	M8×40mm	M8×35mm	M5
(V) × 1PC	(P) × 2PCS	(C) × 1PC	(D) × 2PCS	(U) × 1PC



41

	
M6*30mm	M4
(M) × 4PCS	(T) × 1PC

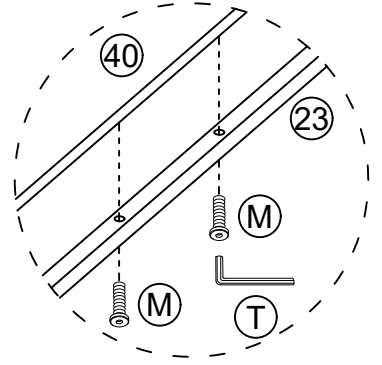
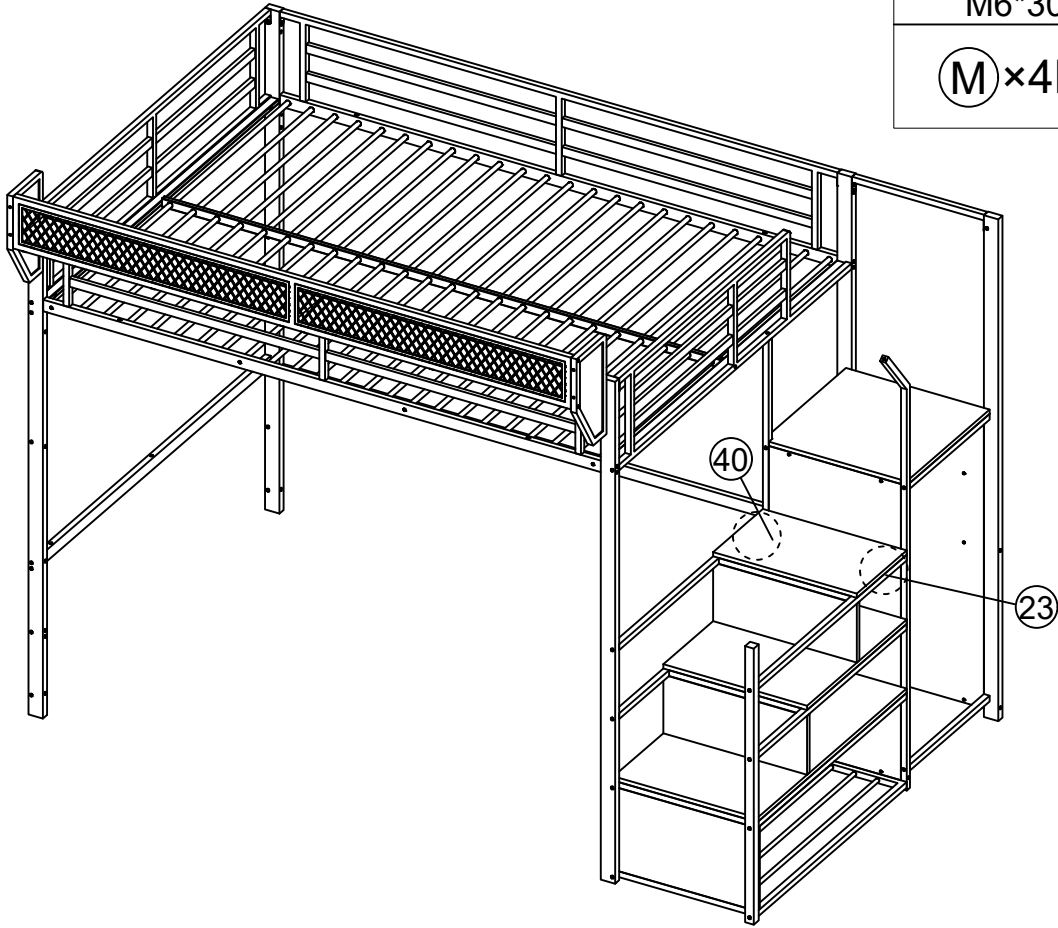

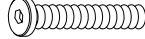
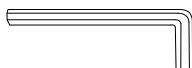

42

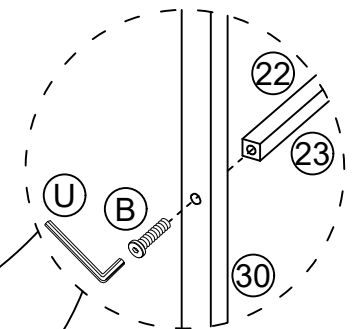
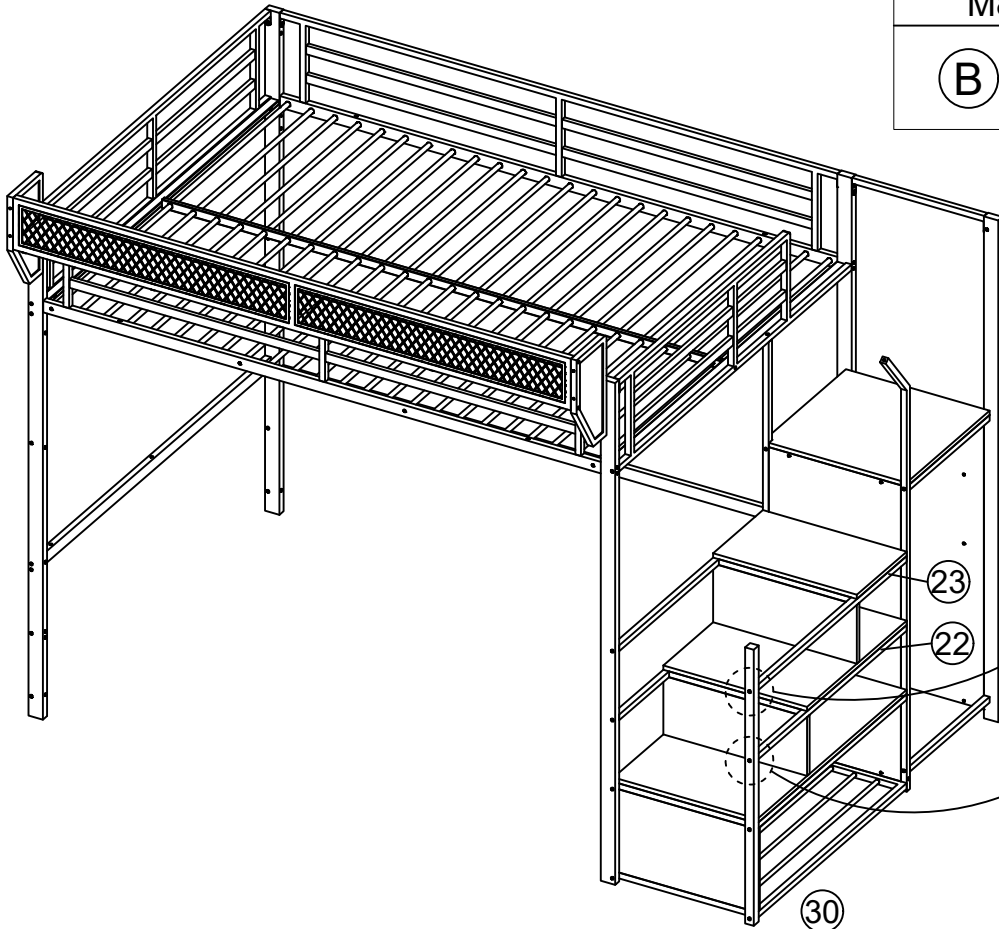
	
M8*50mm	M5
(B) × 2PCS	(U) × 1PC



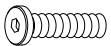

43

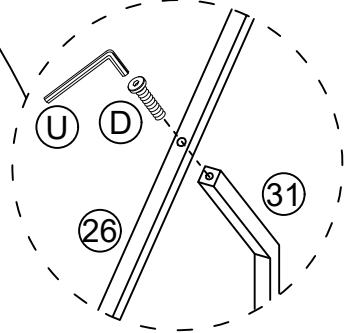
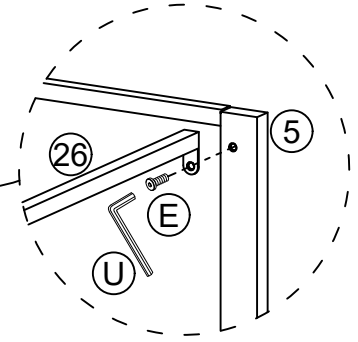
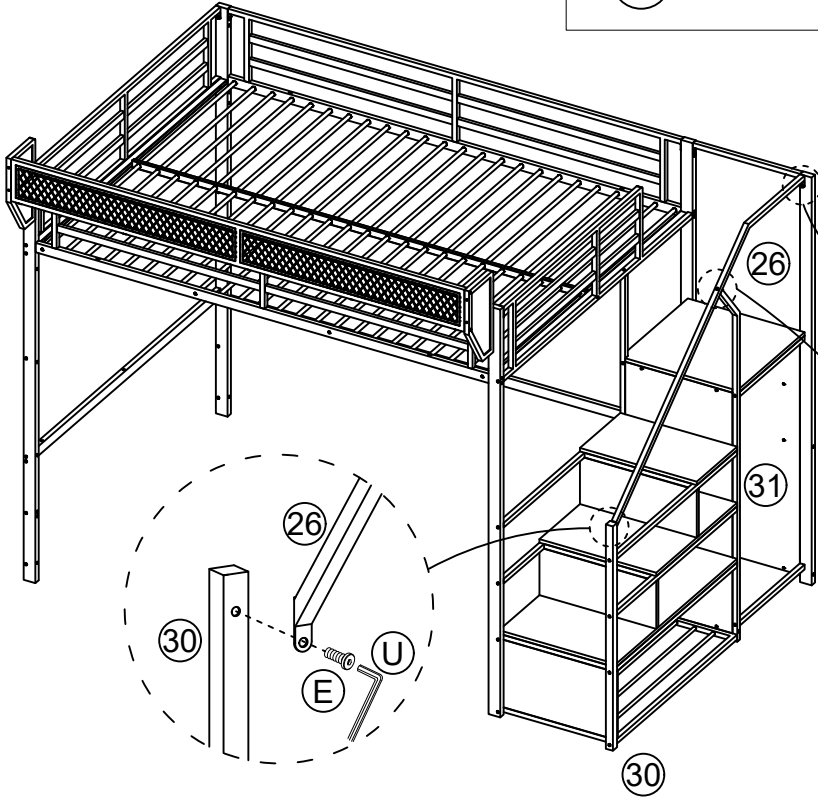
		
M8×35mm	M8×20mm	M5
(D) ×1PC	(E) ×2PCS	(U) ×1PC



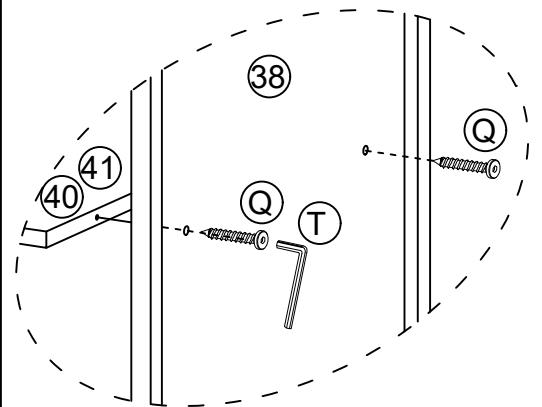
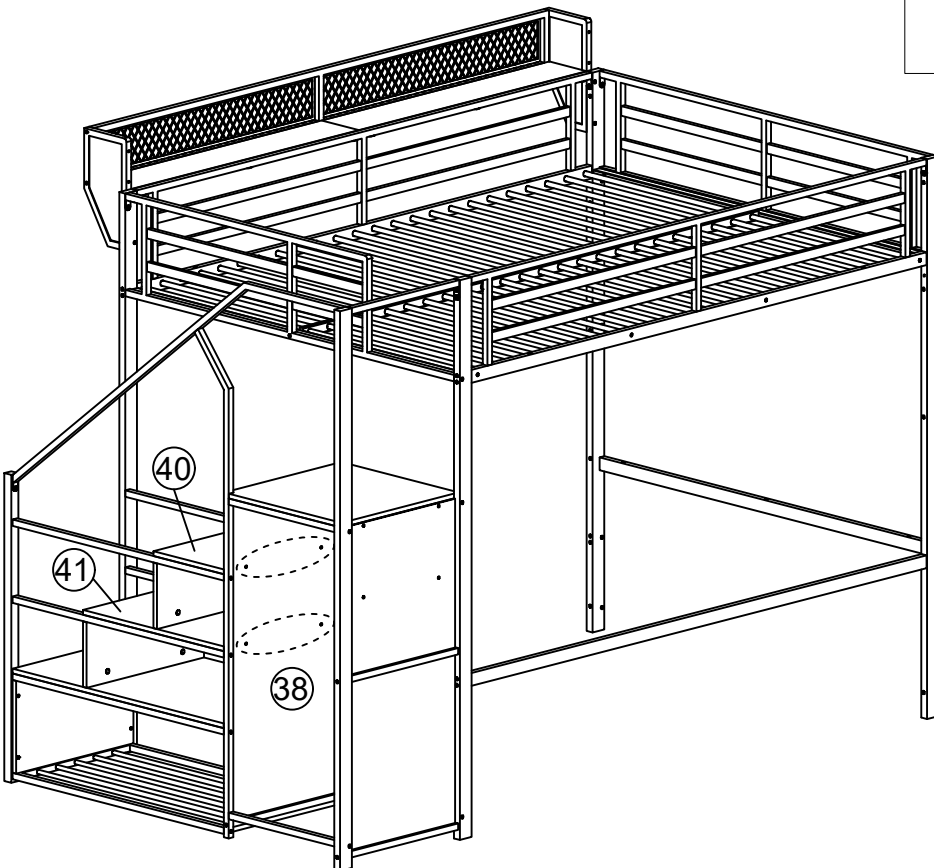

44

	
M5*20mm	M4
(Q) ×4PCS	(T) ×1PC

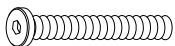

45

		
M6*65mm	M6*30mm	M4
(G) × 5PCS	(M) × 5PCS	(T) × 1PC

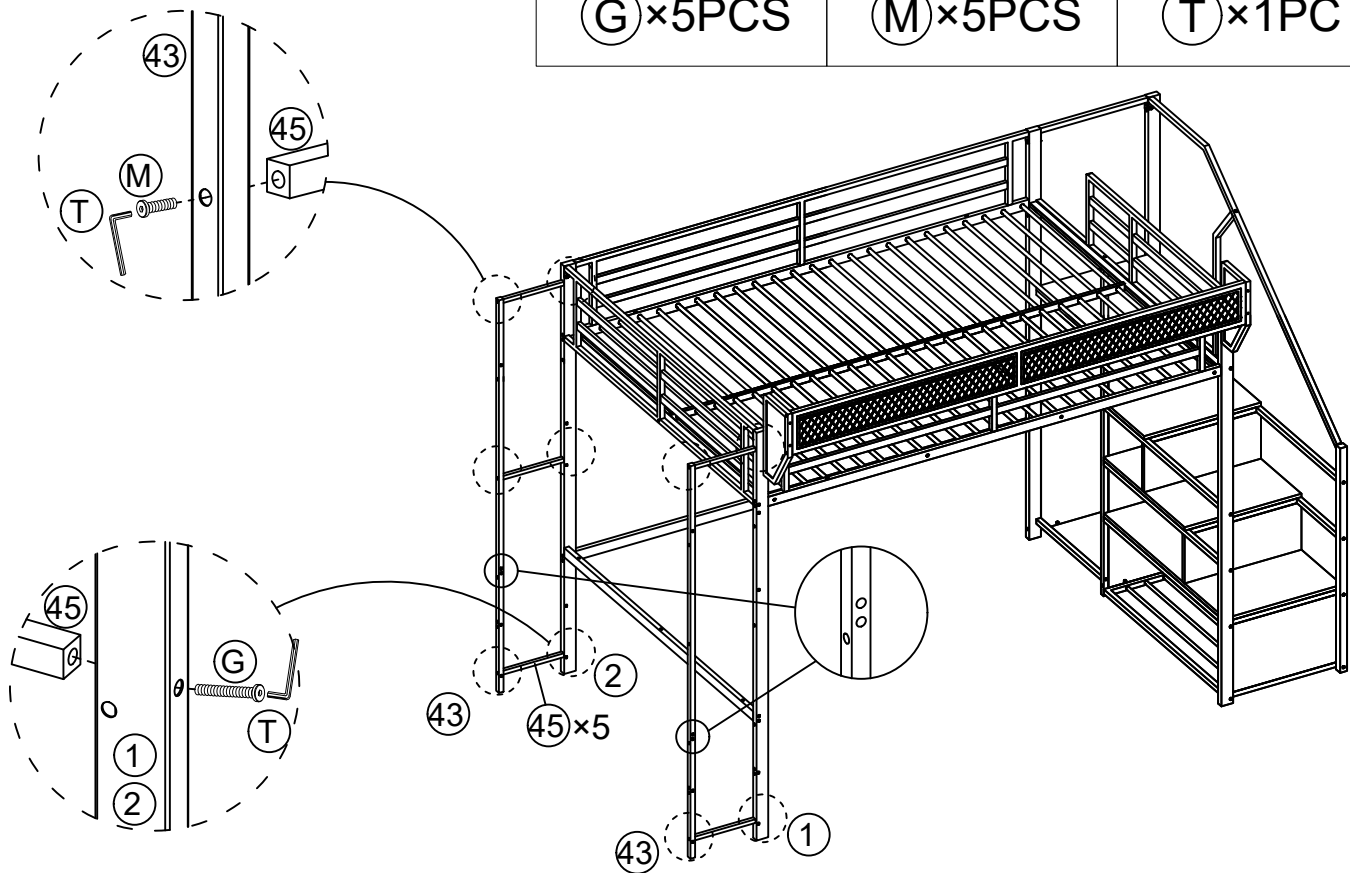

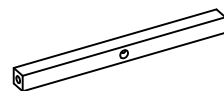
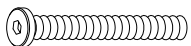
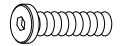
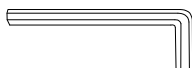

46

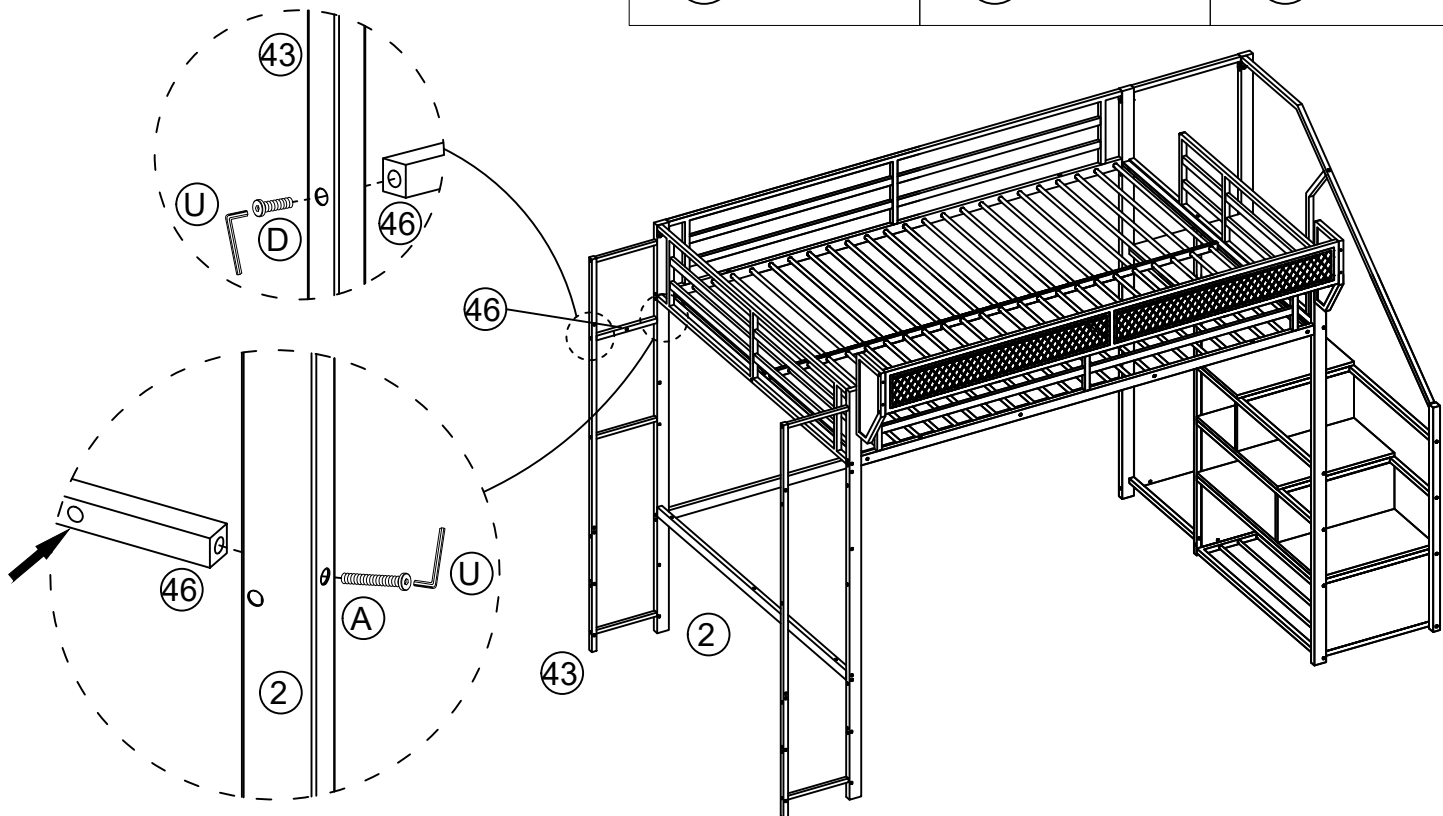
			
	M8*70mm	M8*35mm	M5
(A) × 1PC	(D) × 1PC	(U) × 1PC	



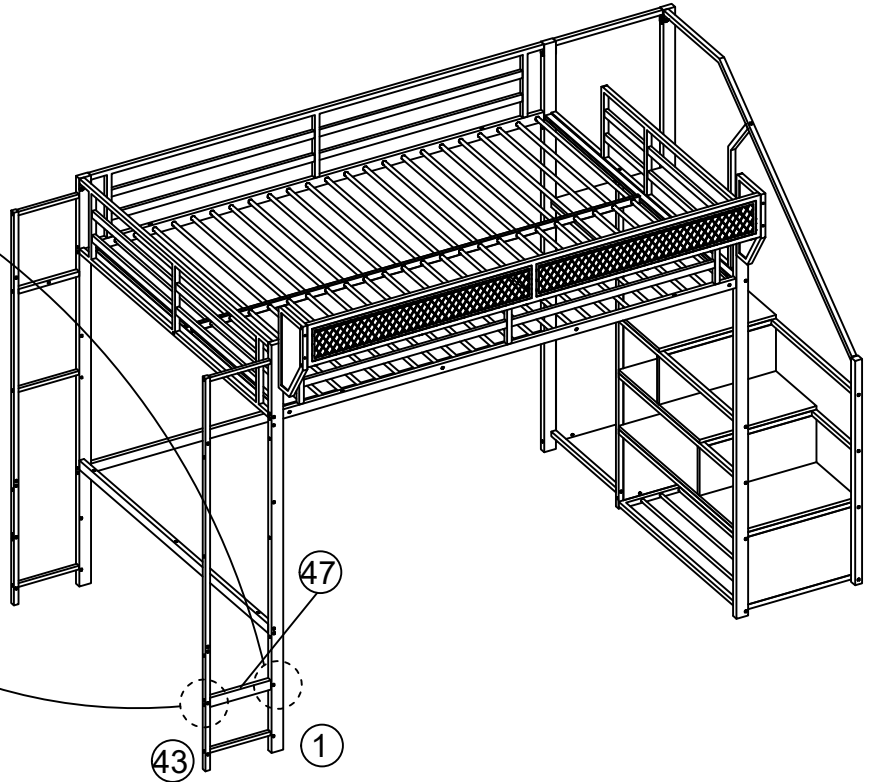
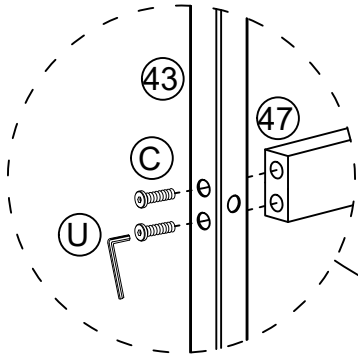
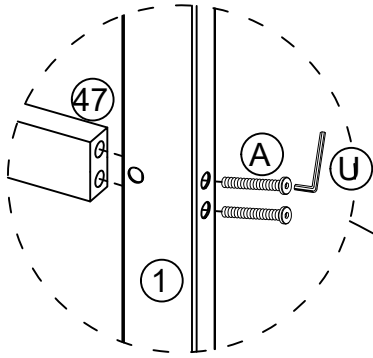

47

		
M8*70mm	M8*40mm	M5
(A) × 2PCS	(C) × 2PCS	(U) × 1PC

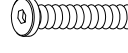

48

	
M8*40mm	M5
(C) × 4PCS	(U) × 1PC

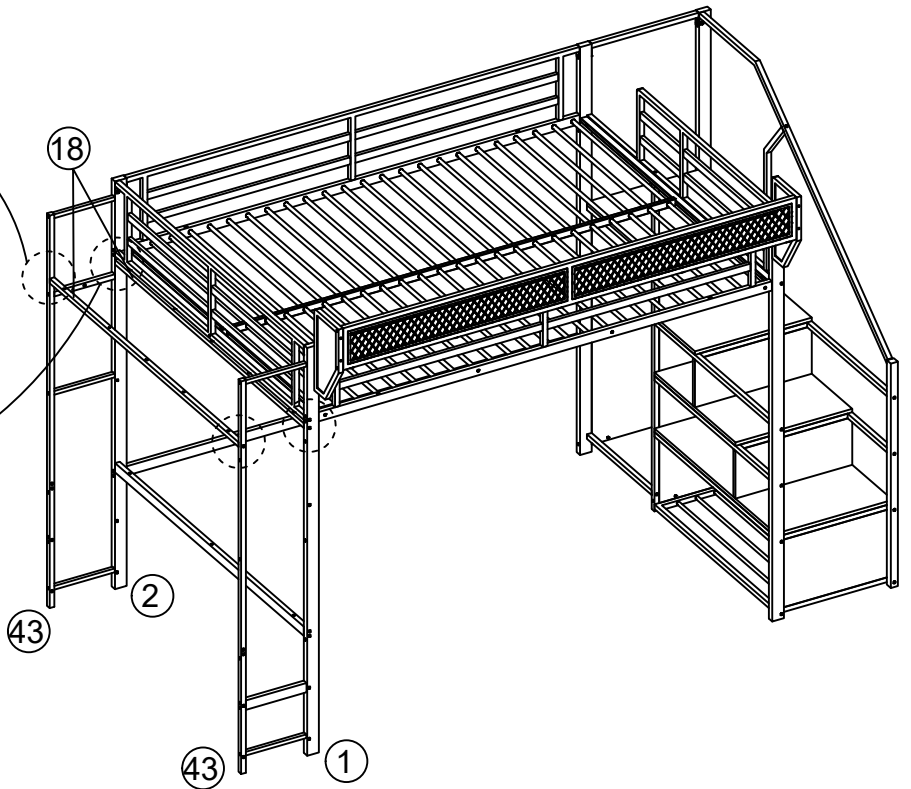
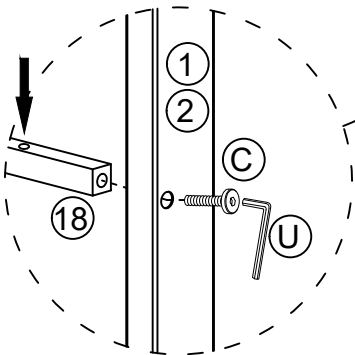
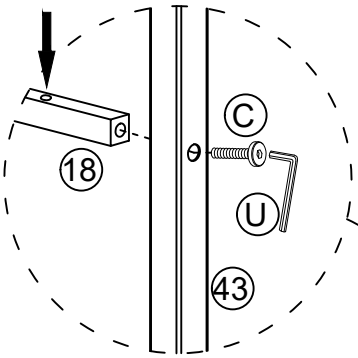

49

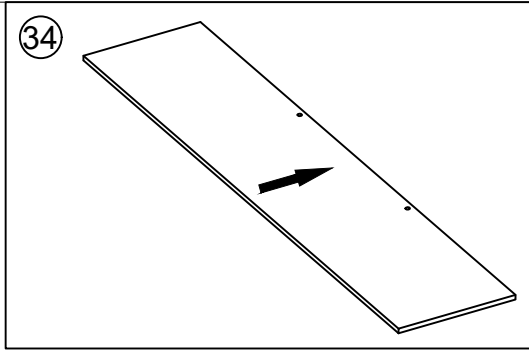

M6*30mm

(M) × 6PCS



M4

(T) × 1PC

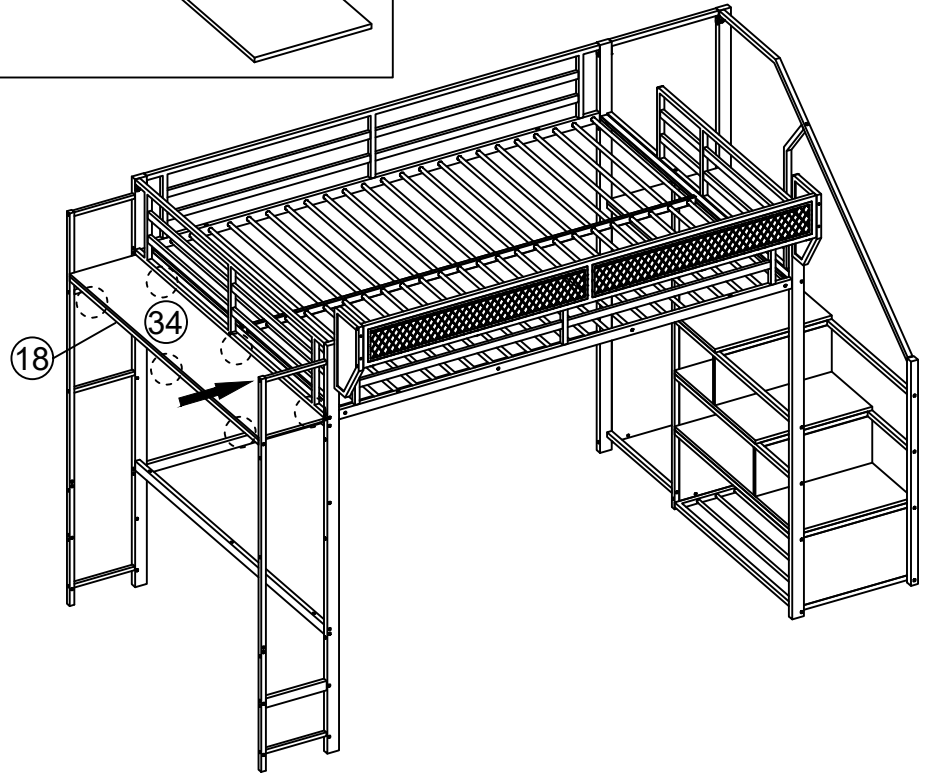
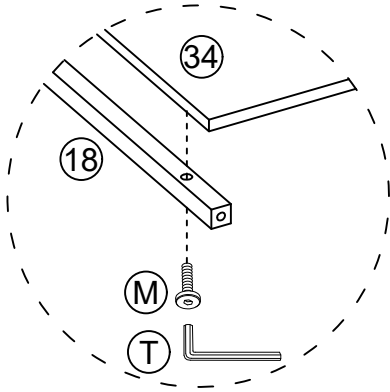

50



M6*15mm

(N) × 2PCS



M4

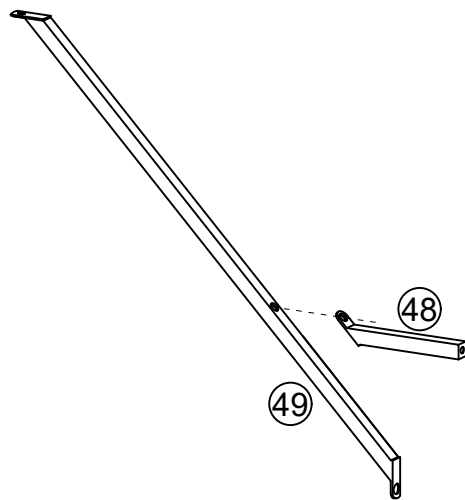

(T) × 1PC

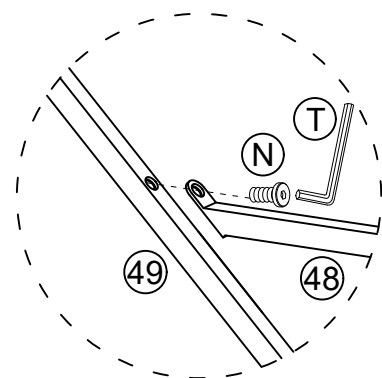

× 2

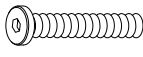

51

 M8×50mm	 M8×20mm	 M5
(B) × 2PCS	(E) × 2PCS	(U) × 1PC

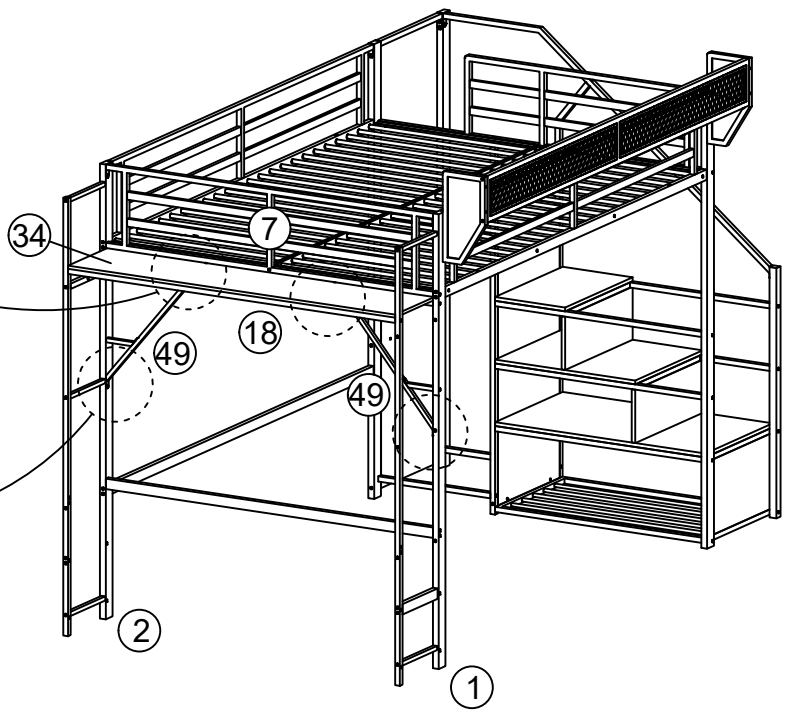
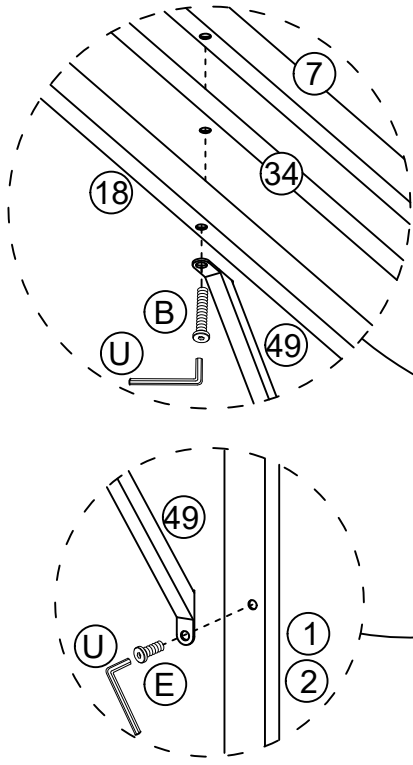

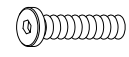
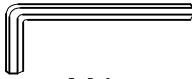

52

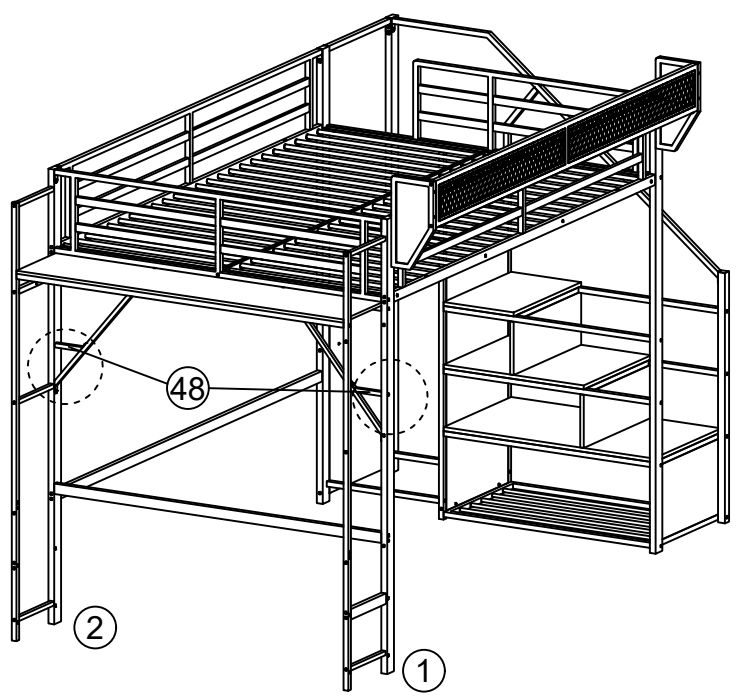
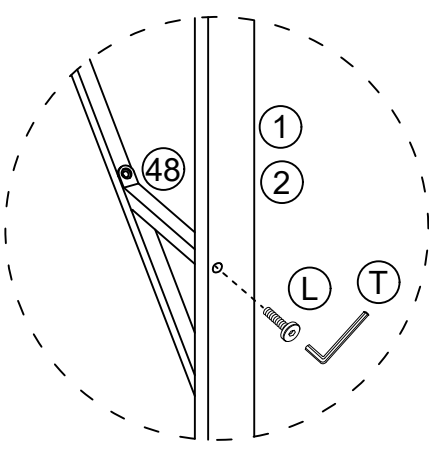
 M6×40mm	 M4
(L) × 2PCS	(T) × 1PC



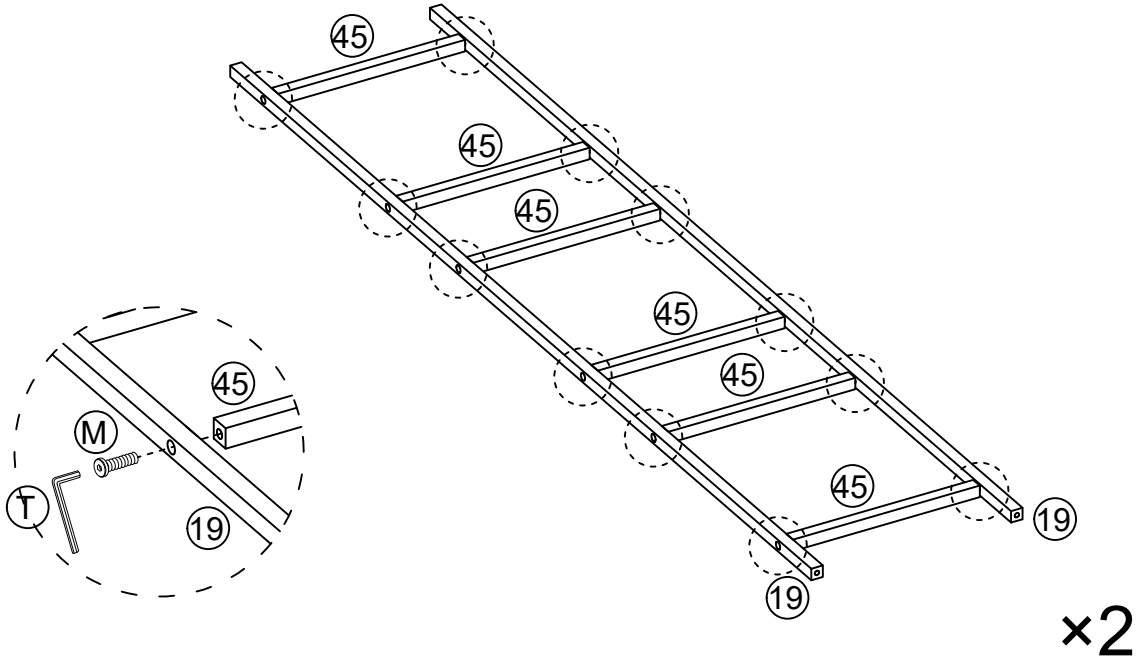

53

 M6*30mm	 M4
(M) × 24PCS	(T) × 1PC



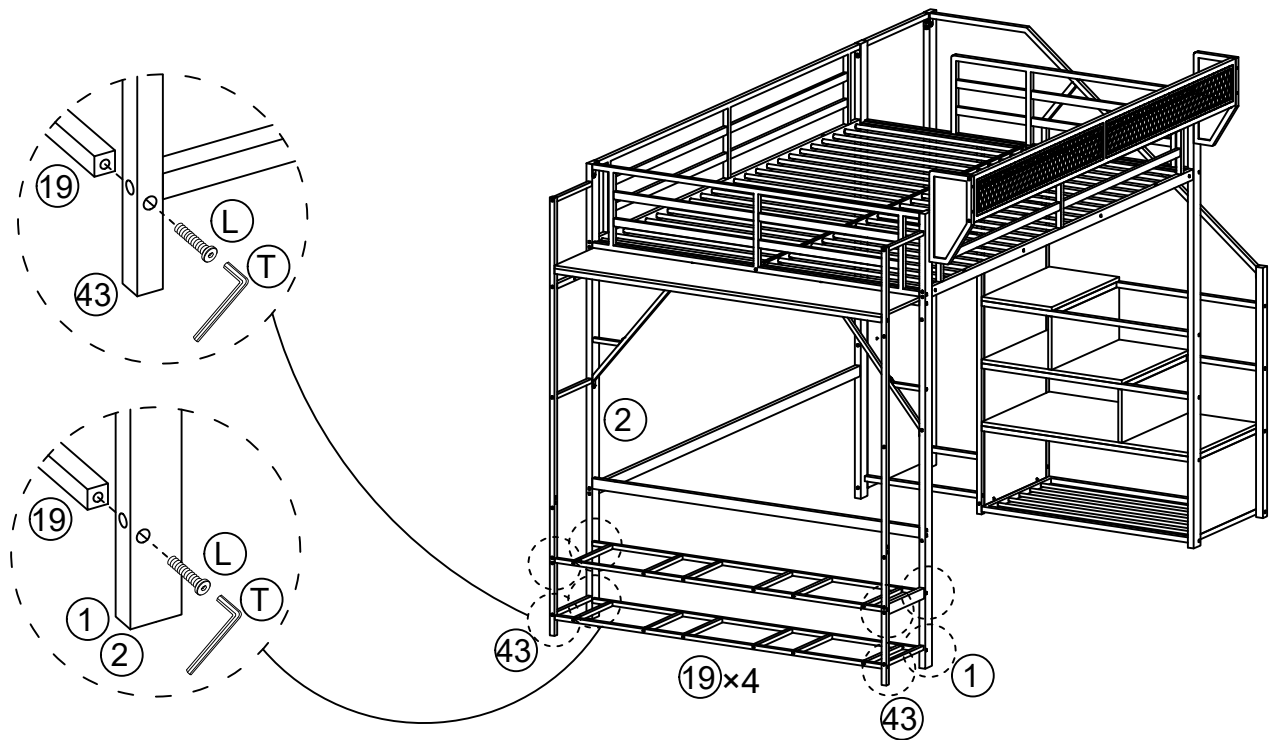

54

 M6×40mm	 M4
(L) × 8PCS	(T) × 1PC



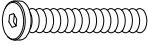

55

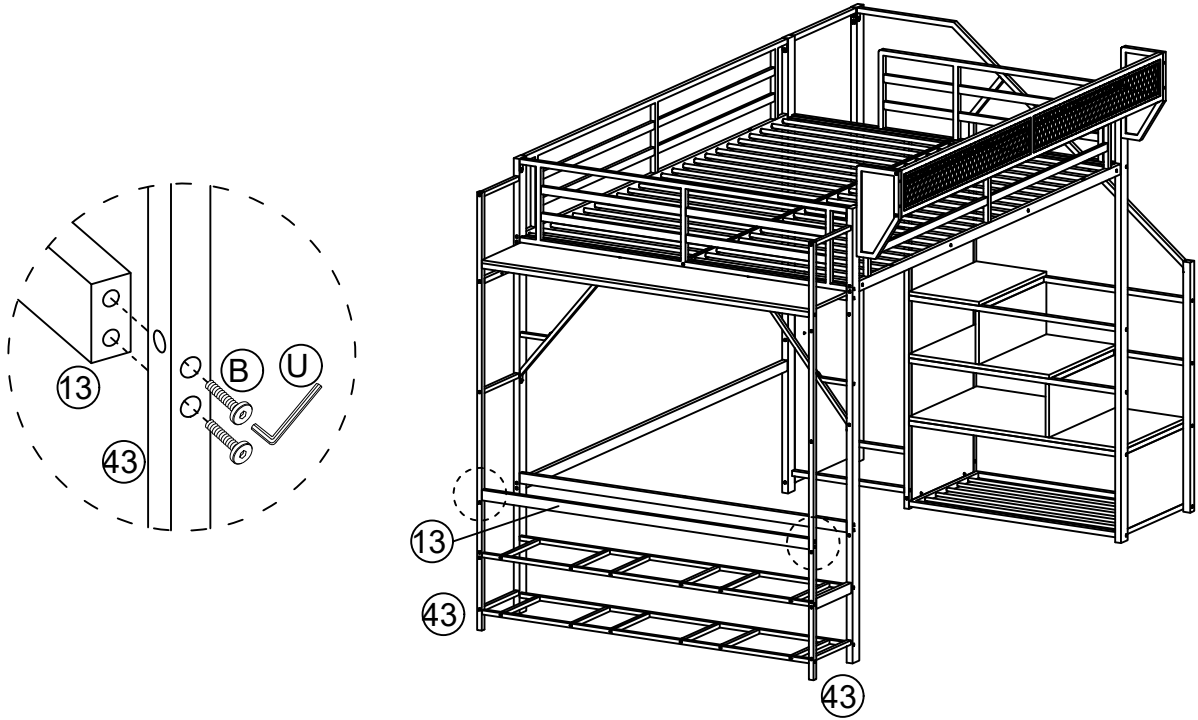
	
M8×50mm	M5
(B) ×4PCS	(U) ×1PC



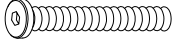

56

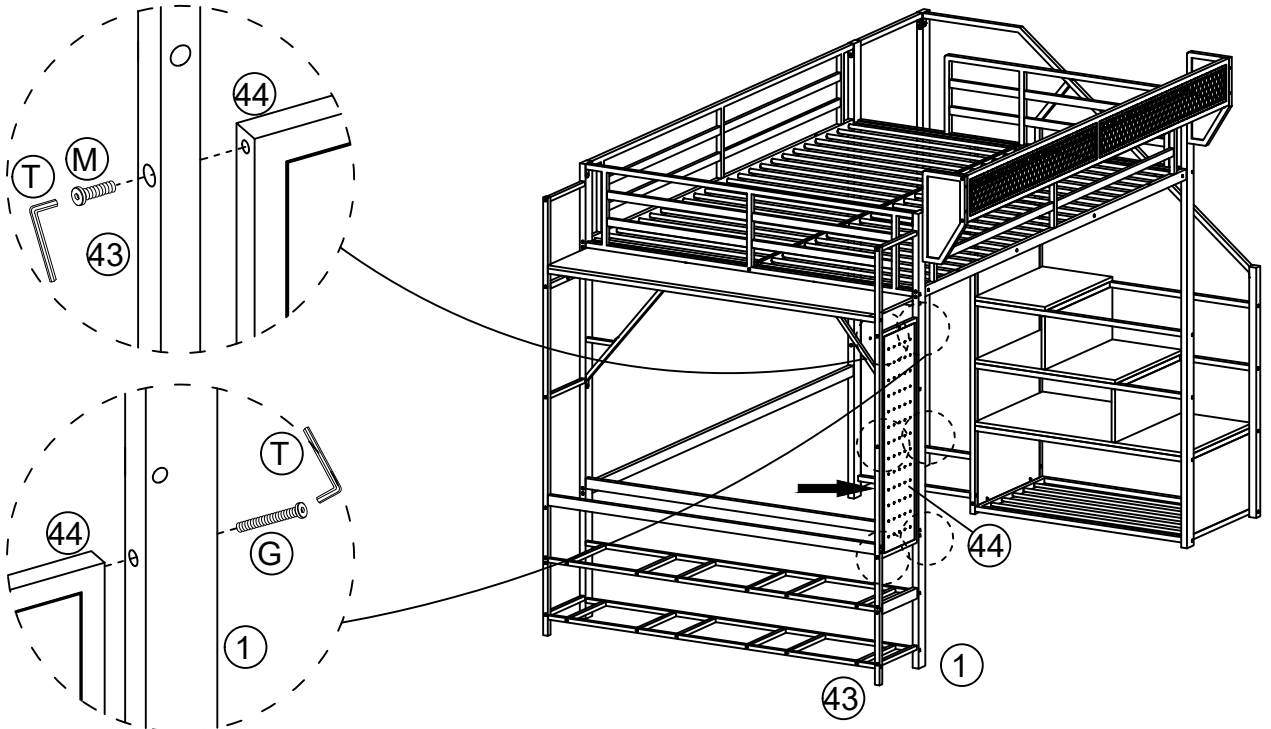
			
	M6*65mm	M6*30mm	M4
	(G) ×3PCS	(M) ×3PCS	(T) ×1PC



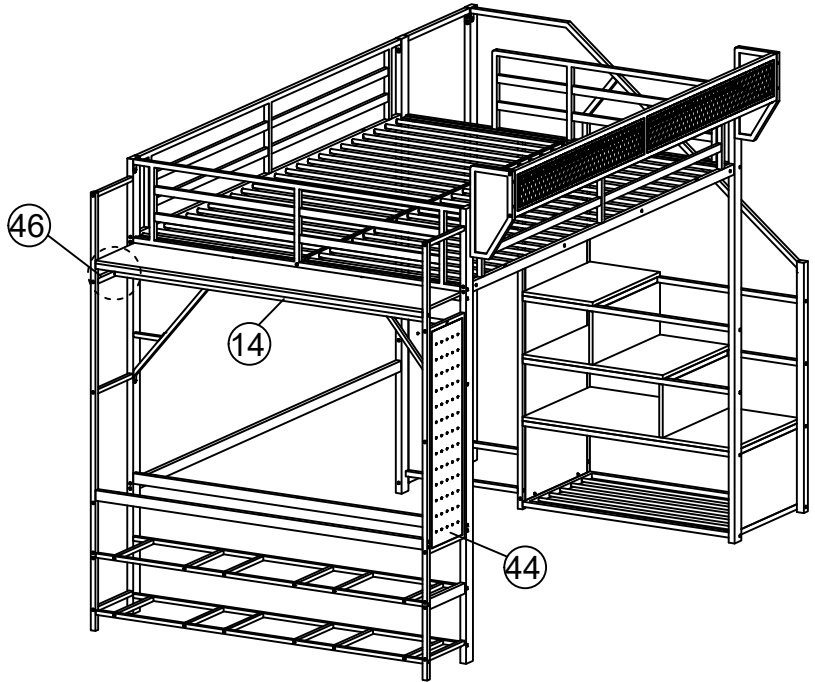
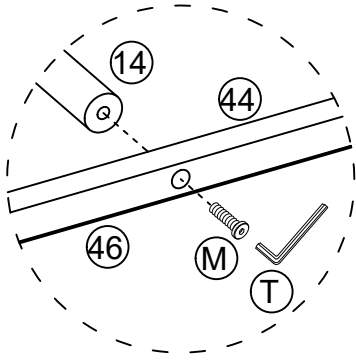

57

	
M6*30mm	M4
(M) × 2PCS	(T) × 1PC

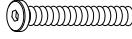

58

	
M6×48mm	M4
(K) × 6PCS	(T) × 1PC

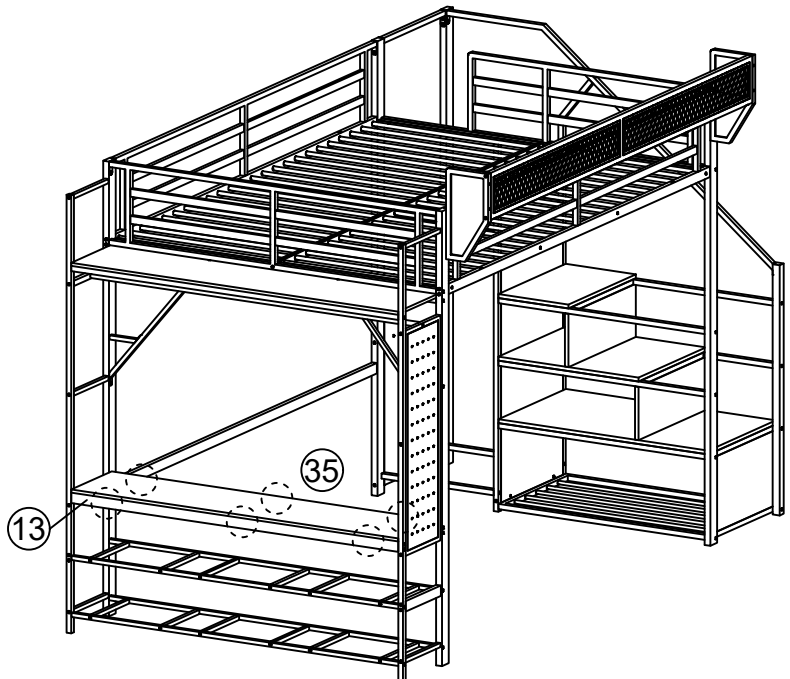
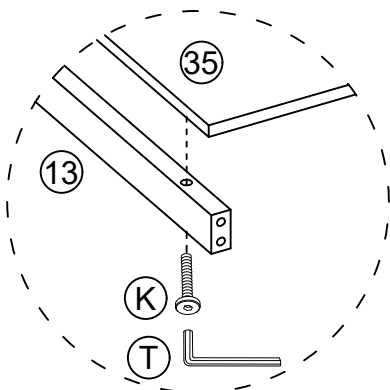

59

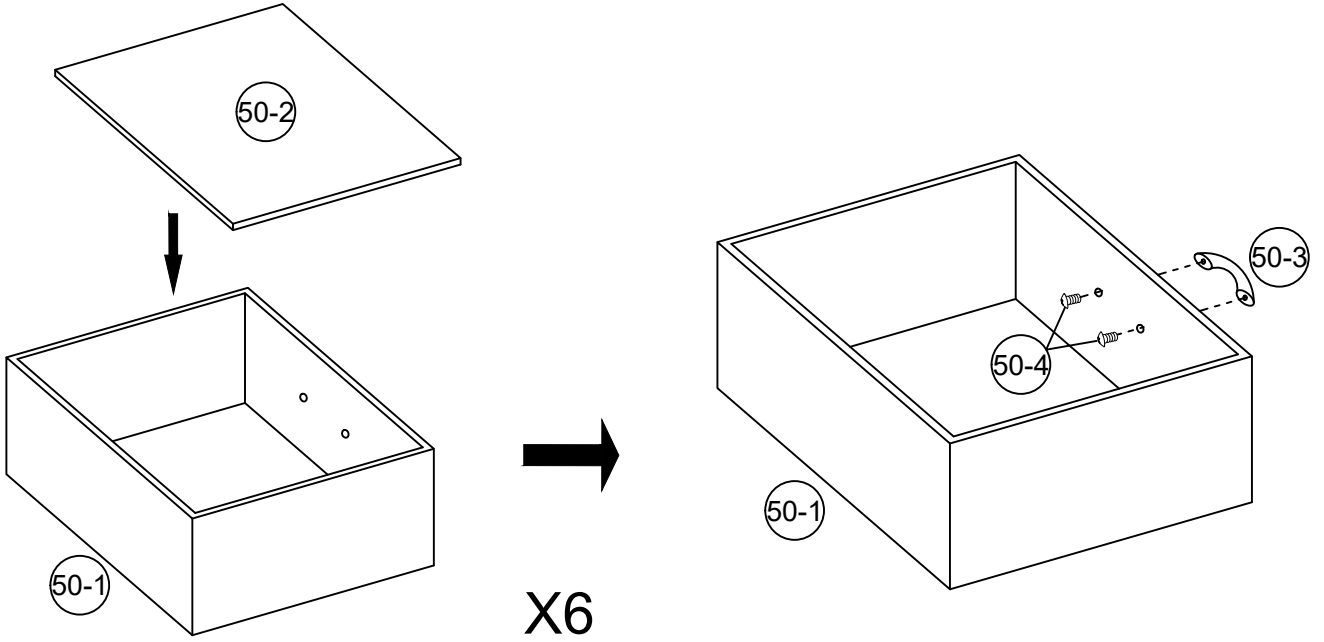
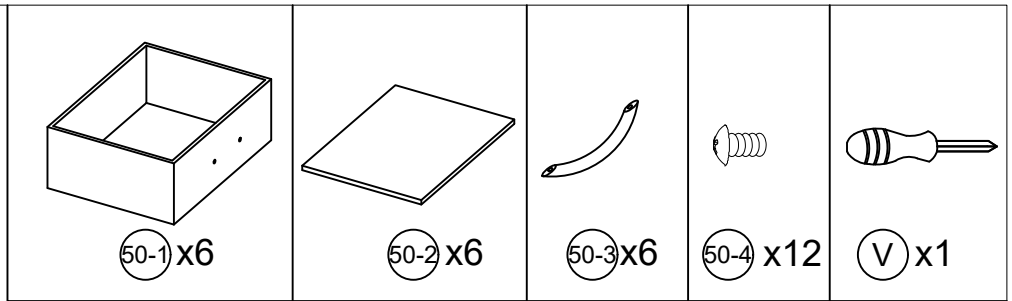

60

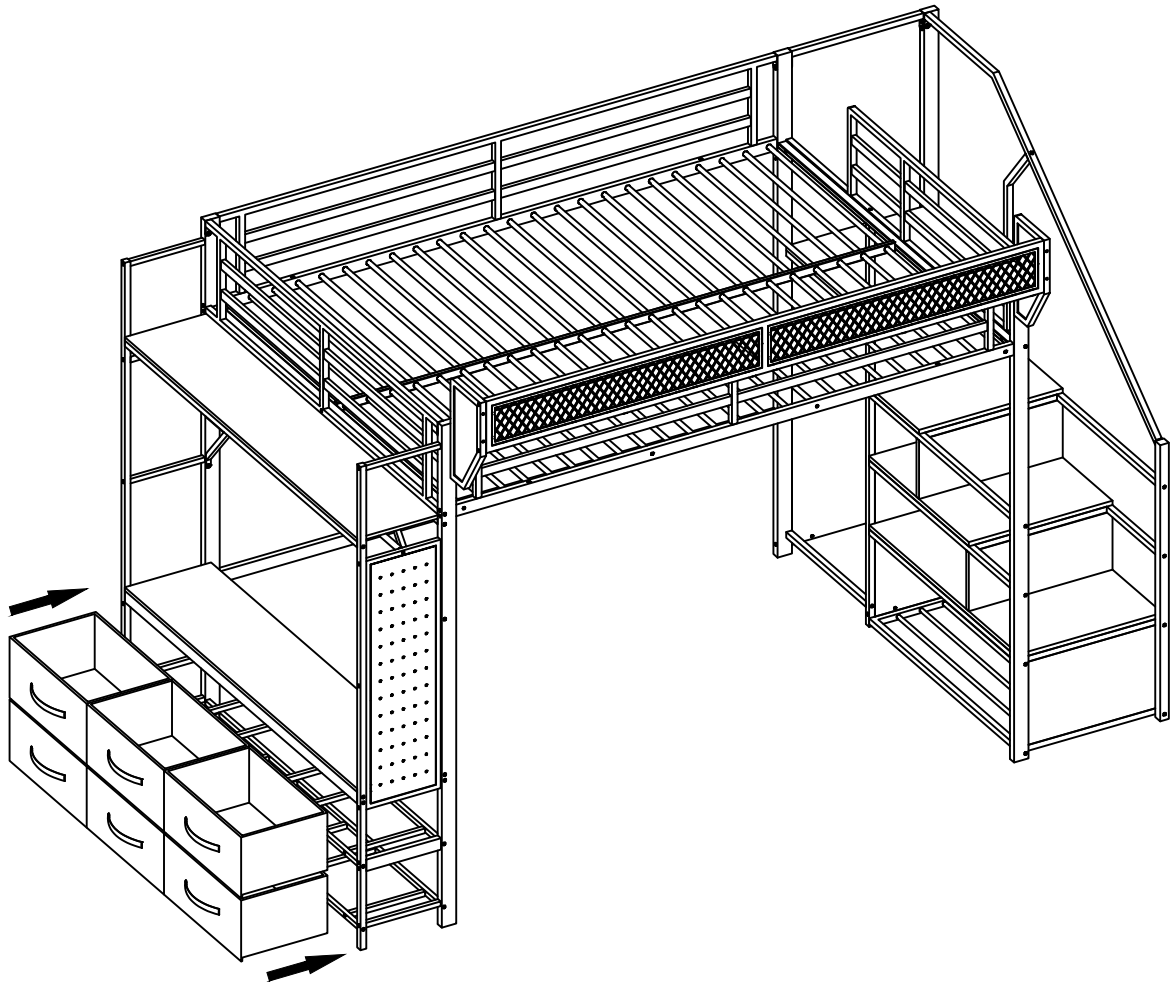

61

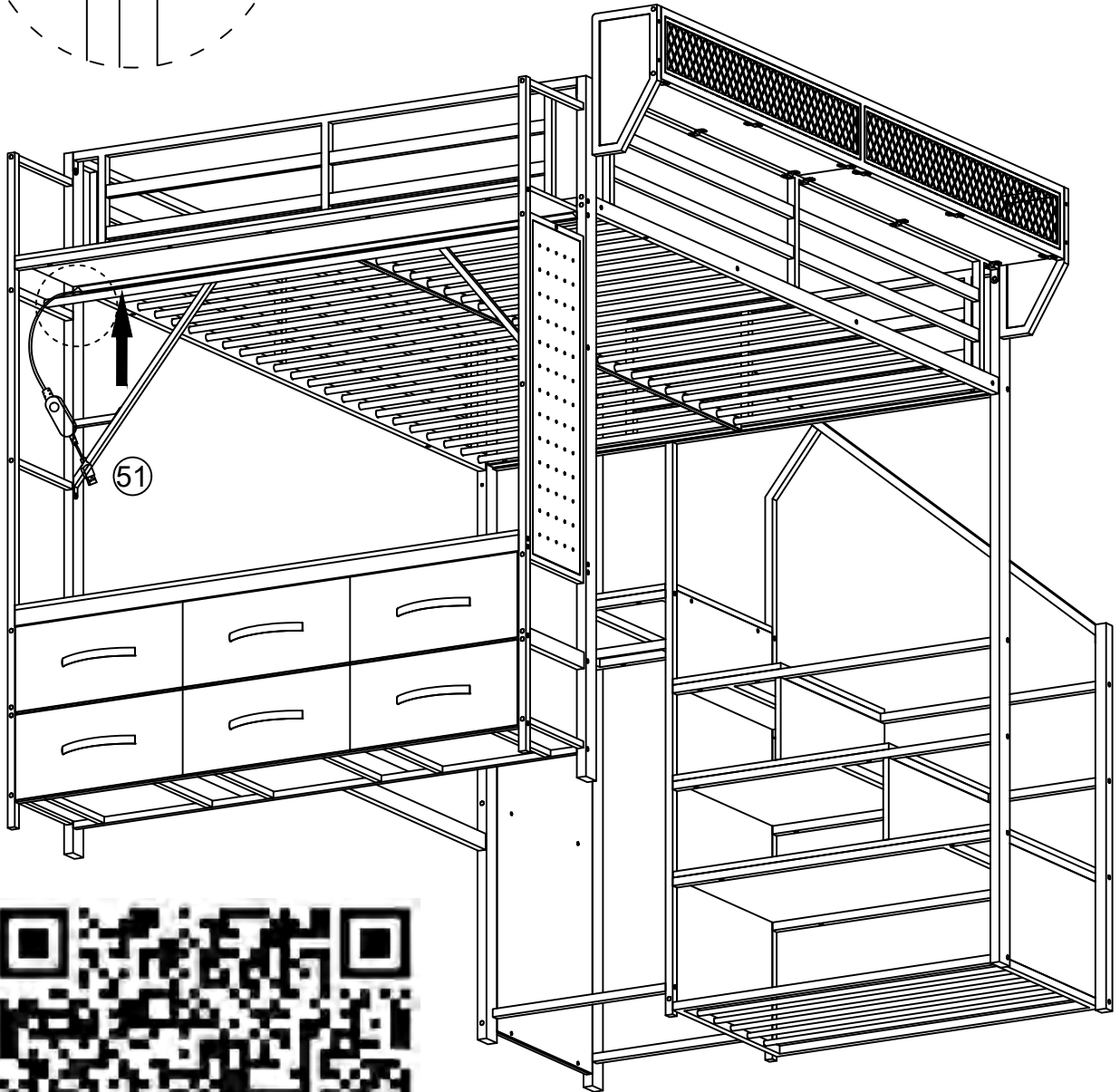
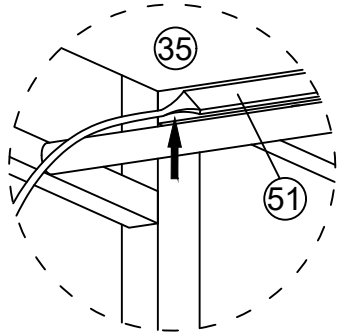
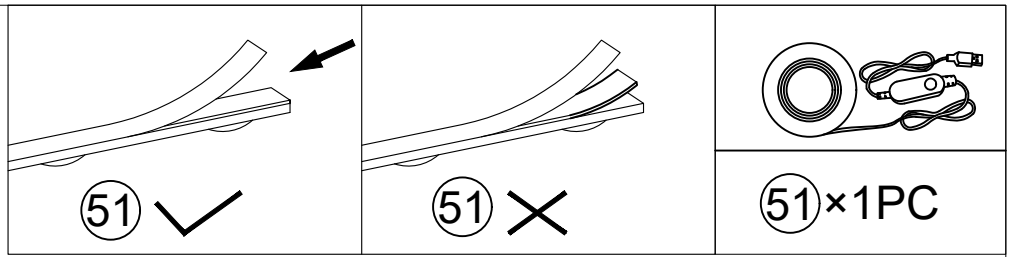

EN Scan to download App control the Led light.
DE Scannen, um die App zum Steuern des LED-Lichts herunterzuladen.
FR Scanner pour télécharger App contrôler la lumière Led.

62



(Z) × 4PCS

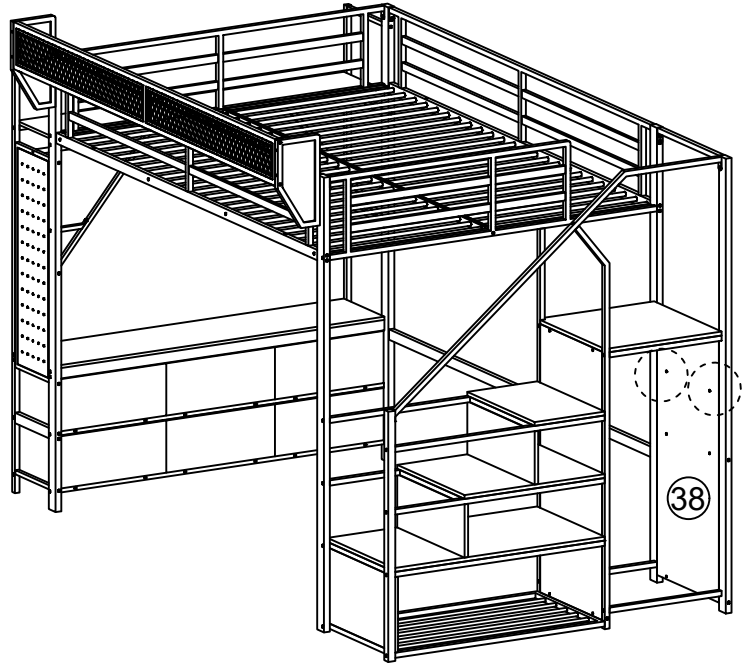
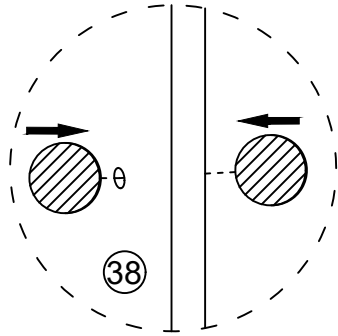







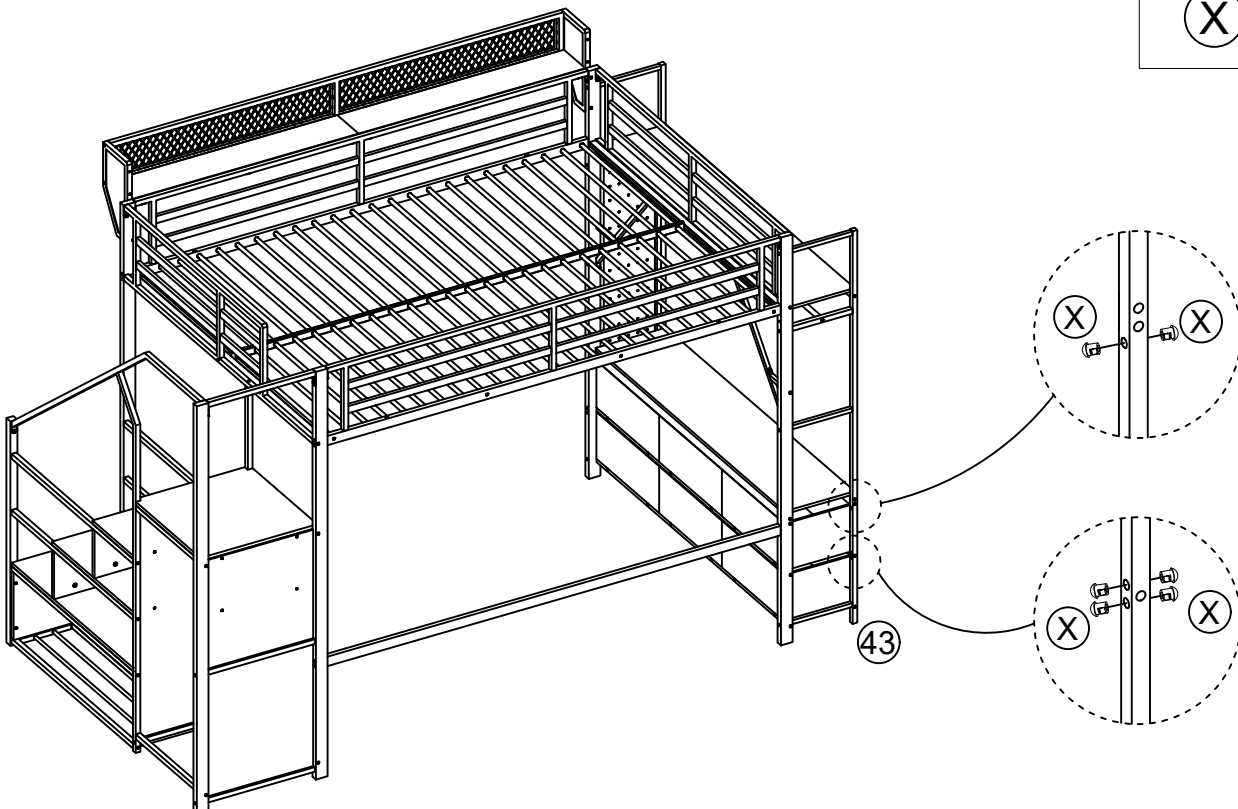

63

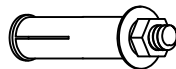
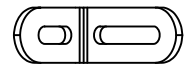

(X) × 6PCS



64

 M4	 M6×15mm			
(T)×1PC	(N)×2PCS	(J)×1PC	(I)×2PCS	(H)×2PCS
		 (15)	 (14)	 (13)
			 (12)	 (11)

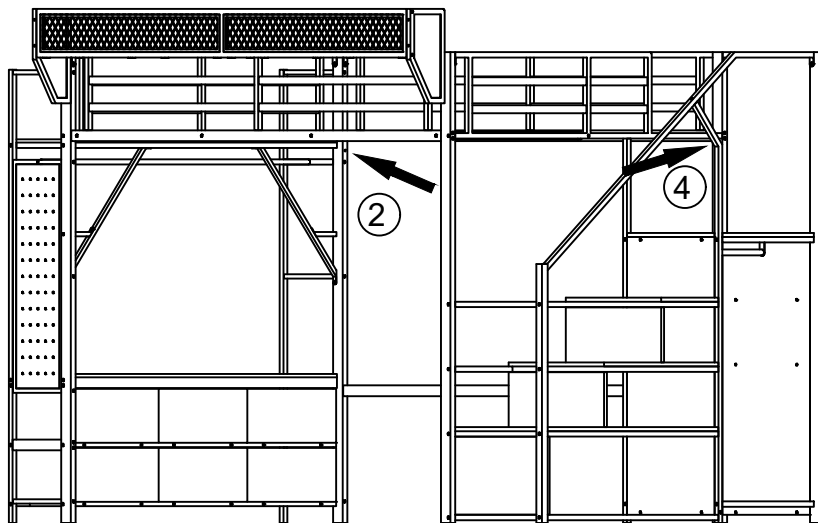
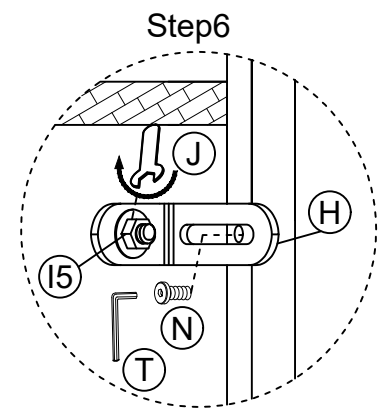
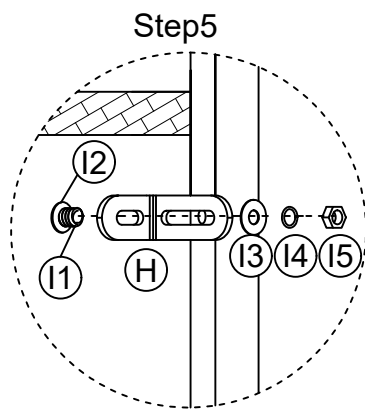
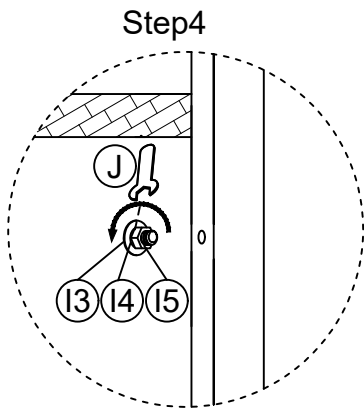
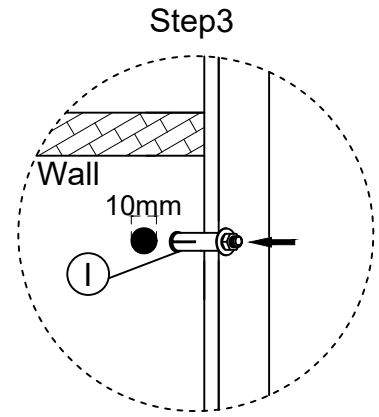
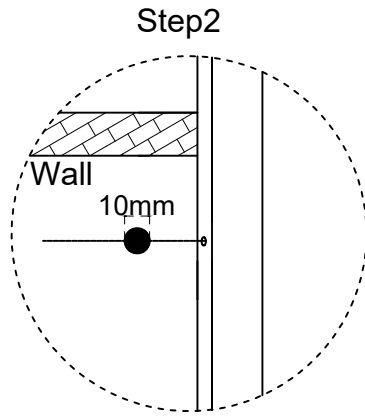
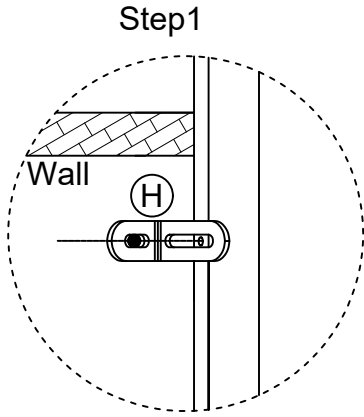

EU DECLARATION OF CONFORMITY

1. Product model/product:

HZY-5050RGB-30D-5V Lamp strip, DC5V, 2.5/meter

2. Name and address of the manufacturer:

Shenzhen Hongzhengyu Technology Co., Ltd

A, 5th Floor, Building 3, Haitian Lanyu Industrial Science and Technology Industrial Park, Shiyan Street, Bao'an District, Shenzhen, China

3. This declaration of conformity is issued under the sole responsibility of the manufacturer.

4. Object of the declaration:

HZY-5050RGB-30D-5V Lamp strip (DC5V, 2.5 LEDs/meter) – as identified by the manufacturer's logo "HZY" or "Shenzhen Hongzhengyu" on the product body or packaging.

5. The object of the declaration described above is in conformity with the relevant Union harmonisation legislation:

- EMC Directive 2014/30/EU
- RoHS Directive 2011/65/EU as amended by (EU) 2015/863 and (EU) 2017/2102

6. References to the relevant harmonised standards used:

- EN IEC 55015:2019+A1:2020
- IEC 61547:2020
- IEC 62321-1:2013, IEC 62321-3-1:2013, IEC 62321-4:2013/AMD1:2017, IEC 62321-5:2013, IEC 62321-6:2015, IEC 62321-7-1:2015, IEC 62321-7-2:2017, IEC 62321-8:2017

7. Additional information:

Use correctly according to the instruction.

8. Signed for and on behalf of:

Shenzhen Hongzhengyu Technology Co., Ltd

Place and date of issue:

Shenzhen, 31 March 2026

Name, function

Xia Xianming General Manager

Signature:



Letter of Authorisation for Use of EU DoC

Date: 31 March 2026

Subject: Authorisation to Use EU Declaration of Conformity for Model YH-358

This letter authorises any entity that lawfully possesses units of model YH-358 LED controller (5V) manufactured by Dongguan Yihong Hardware Electronics Co., Ltd (hereinafter "the Manufacturer") and bearing the Manufacturer's logo ("YH" or "Dongguan Yihong") on the product body to use the EU Declaration of Conformity (DoC) issued by the Manufacturer for that product, under the following conditions:

1. Scope of Authorisation

This authorisation applies exclusively to units that:

- Are model YH-358;
- Bear the Manufacturer's logo;
- Have not been modified without the Manufacturer's written consent.

2. Validity of Authorisation

This authorisation remains valid as long as the commercial relationship between the Manufacturer and the authorised entity continues, or until the product design or applicable legislation changes. In any case, the authorisation does not transfer to third parties unless expressly agreed in writing.

3. Restrictions

The EU DoC shall not be used for:

- Products manufactured by any third party;
- Products without the Manufacturer's logo;
- Any purpose other than demonstrating conformity of the specific units described above.

4. Liability

The Manufacturer assumes no responsibility for misuse of the EU DoC beyond the scope defined herein. Unauthorised use may result in legal action.

Signed for and on behalf of:

Dongguan Yihong Hardware Electronics Co., Ltd

Name, function:

Wenfeng Zeng, General Manager

Signature:



EU DECLARATION OF CONFORMITY

1. Product model / product:

YH-358 LED controller, 5V

2. Name and address of the manufacturer:

Dongguan Yihong Hardware Electronics Co., Ltd

Room 1106, No.2, Shangheng Road, Chang'an Town, Dongguan, China

3. This declaration of conformity is issued under the sole responsibility of the manufacturer.

4. Object of the declaration:

YH-358 LED controller (5V DC input) – as identified by the manufacturer's logo "YH" or "Dongguan Yihong" on the product body.

5. The object of the declaration described above is in conformity with the relevant Union harmonisation legislation:

- Radio Equipment Directive (RED) 2014/53/EU
- RoHS Directive 2011/65/EU & Commission Delegated Directive (EU) 2015/863

6. References to the relevant harmonised standards used:

- EN IEC 62368-1:2024+A11:2024
- ETSI EN 301 489-1 V2.2.3 (2019-11)
- ETSI EN 301 489-17 V3.3.0 (2024-07)
- ETSI EN 300 328 V2.2.2 (2019-07)
- EN IEC 62311:2020, EN 50665:2017
- IEC 62321-1:2013, IEC 62321-2:2021, IEC 62321-3-1:2013, IEC 62321-3-2:2020, IEC 62321-4:2013+AMD1:2017, IEC 62321-5:2013, IEC 62321-6:2015, IEC 62321-7-1:2015, IEC 62321-7-2:2017, IEC 62321-8:2017

7. Additional information:

Use according to the manufacturer's instruction.

8. Signed for and on behalf of:

Dongguan Yihong Hardware Electronics Co., Ltd

Place and date of issue:

Dongguan, 31 March 2026

Name, function:

Wenfeng Zeng, General Manager

Signature:

