

BOX 17

160523

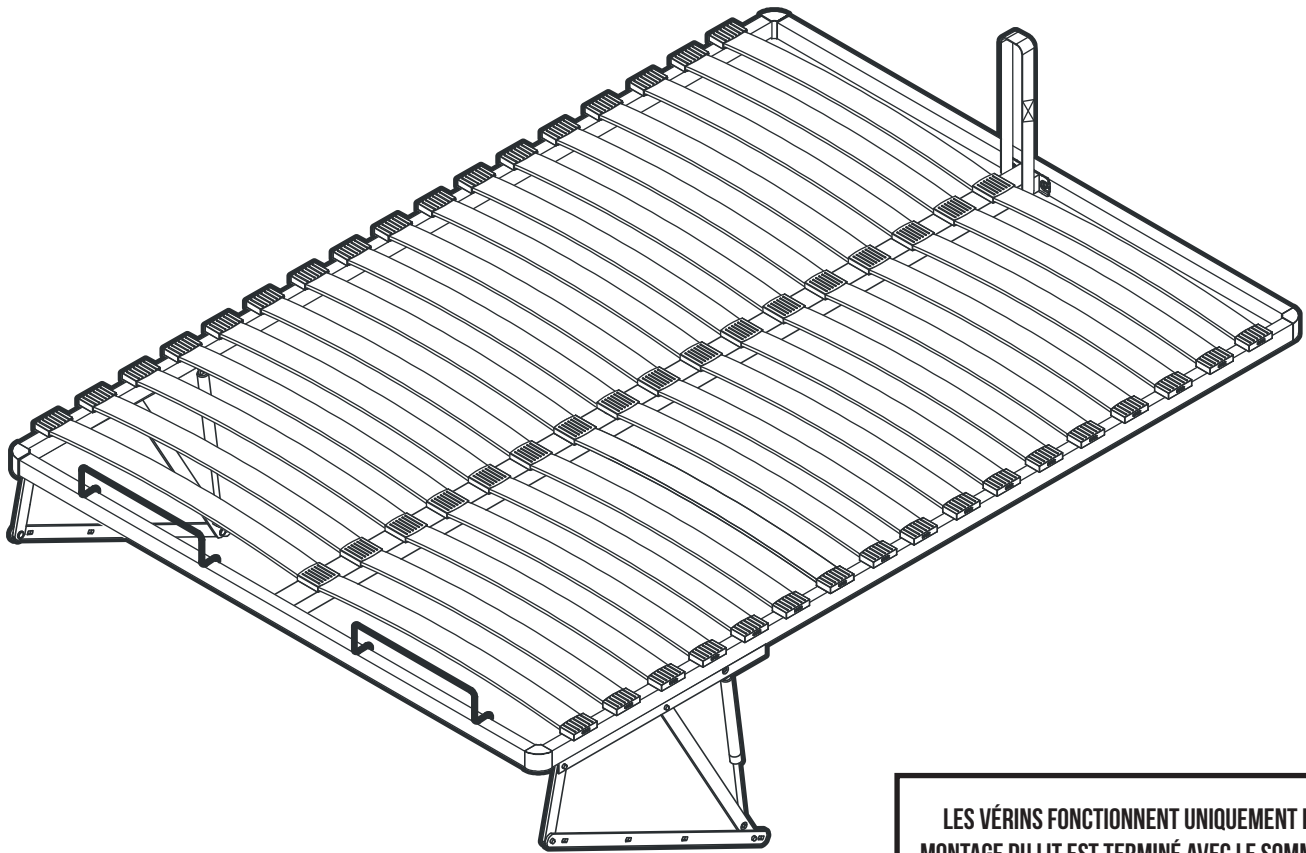

LES VÉRINS FONCTIONNENT UNIQUEMENT LORSQUE LE MONTAGE DU LIT EST TERMINÉ AVEC LE SOMMIER INSTALLÉ ET FIXÉ SUR LA STRUCTURE.

ASSUREZ UNE PRESSION NÉCESSAIRE POUR FAIRE DESCENDRE LE SOMMIER ET DÉBLOQUER LES VÉRINS UNE FOIS LE MONTAGE TERMINÉ.

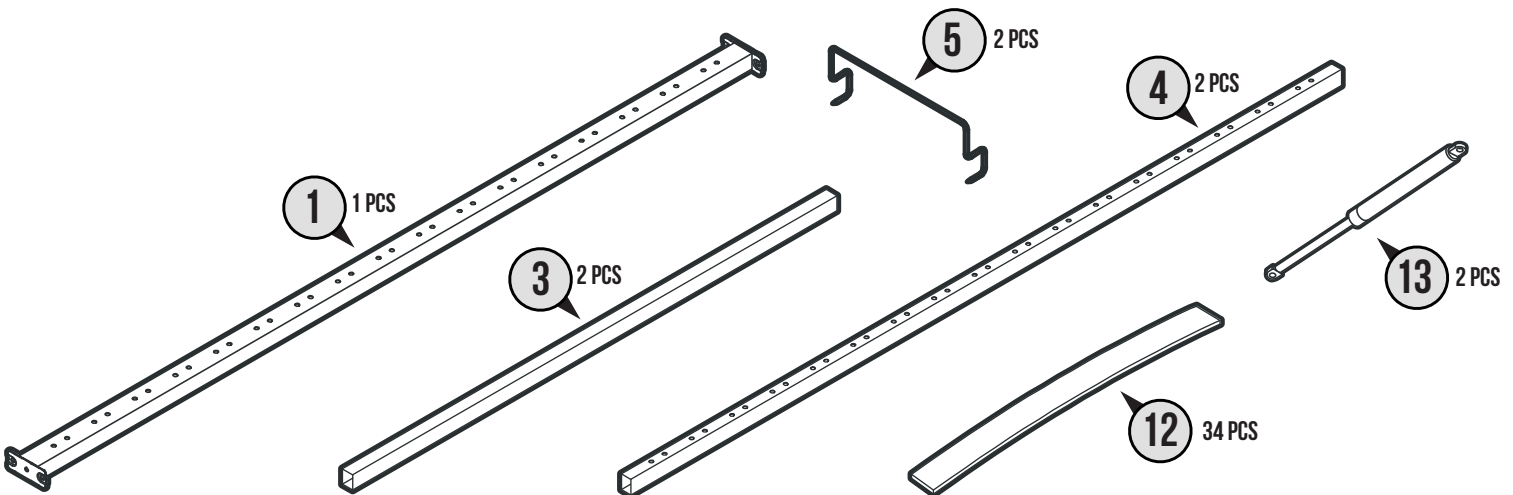
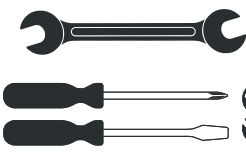

2-1 PCS



6-4 PCS



7-4 PCS



8-8 PCS



9-1 PCS



10-34 PCS



11-17 PCS



14-4 PCS

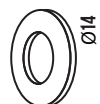

15-8 PCS

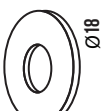

16-4 PCS

BOX 17

160523

1

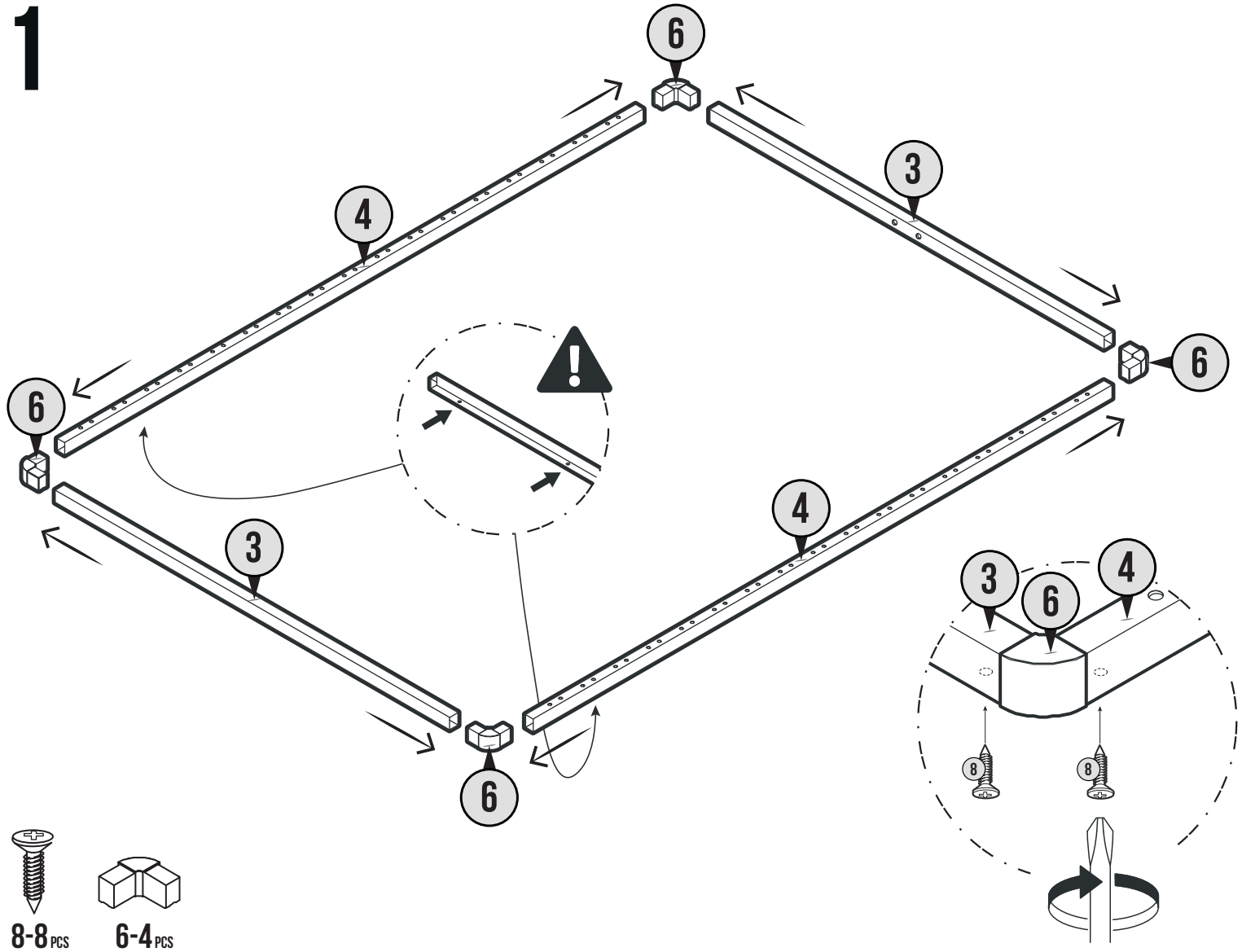

2

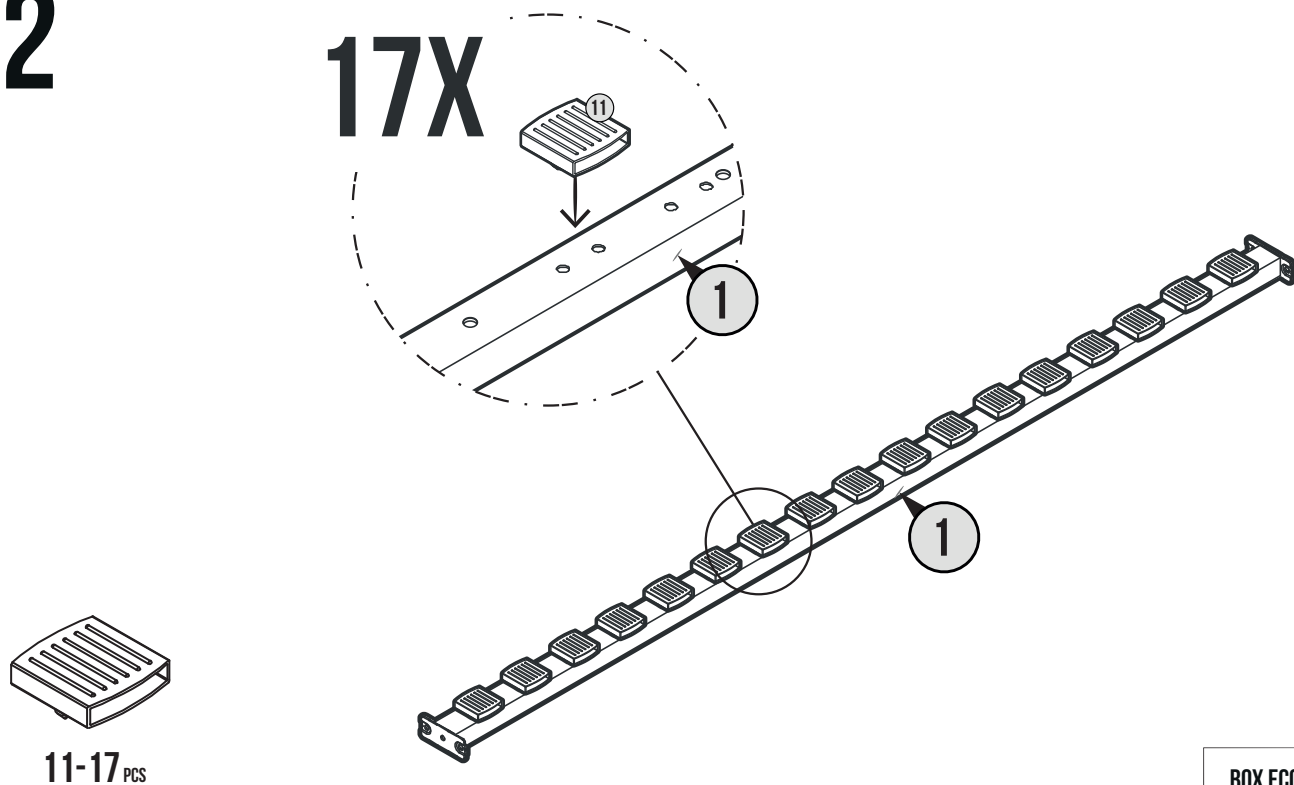

BOX 17

160523

3

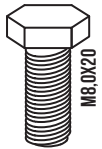
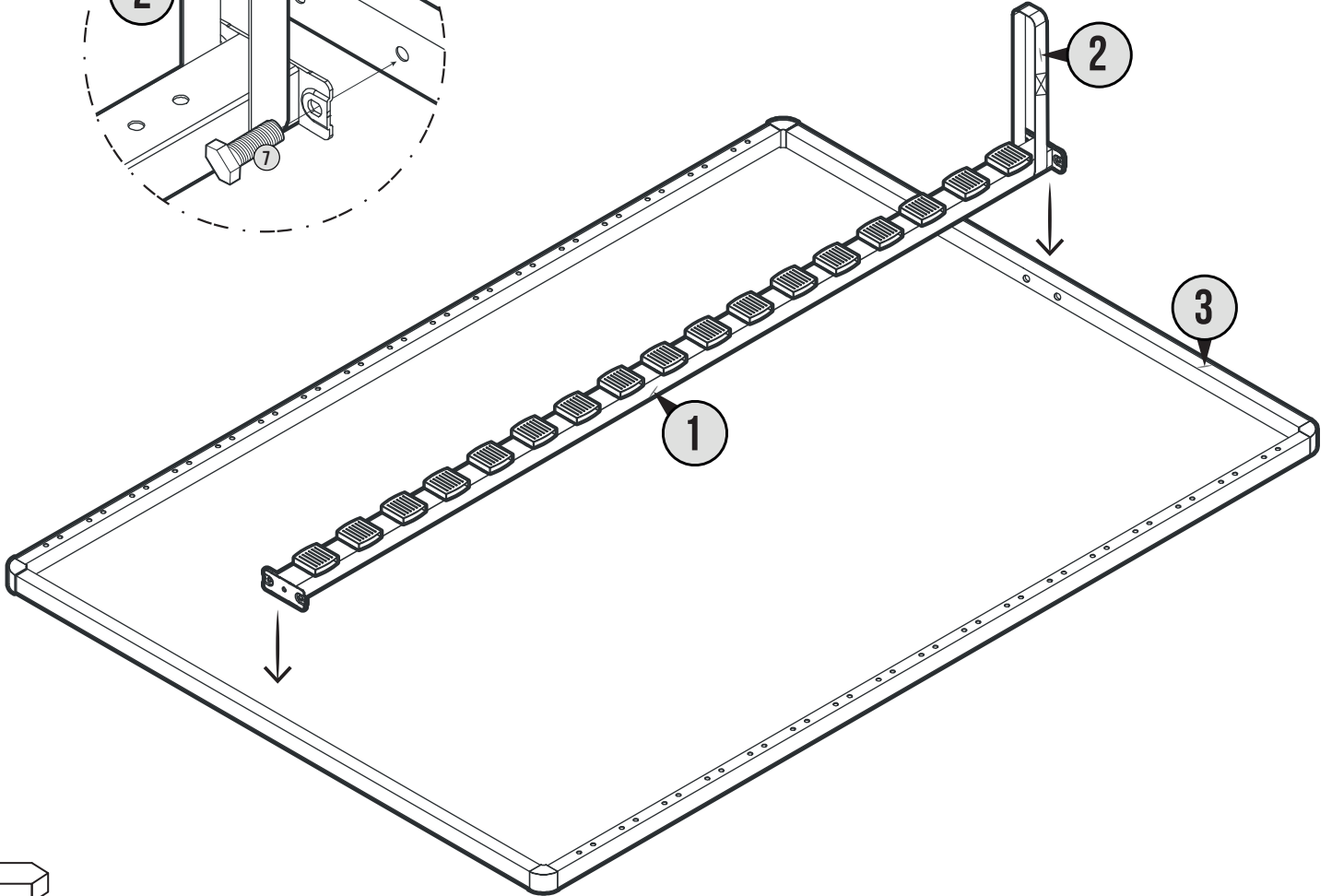
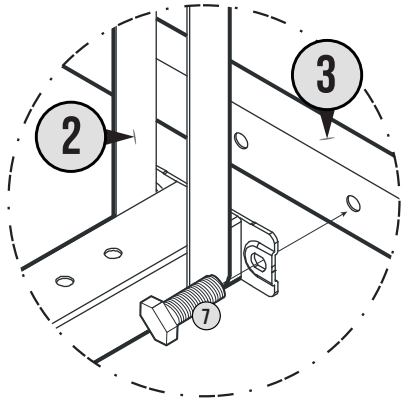

7-4 PCS

4

2X

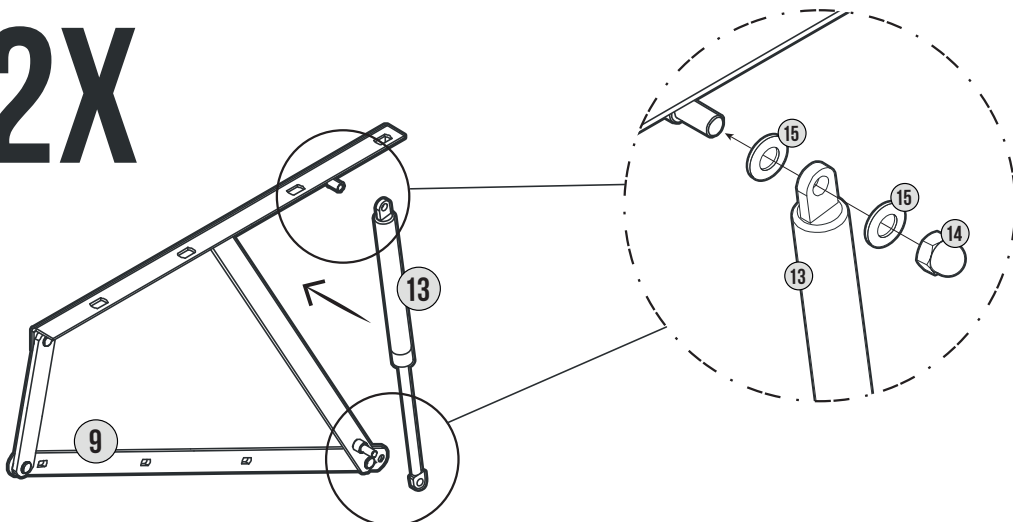

14-4 PCS

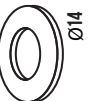

15-8 PCS

BOX 17

160523

5

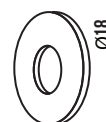
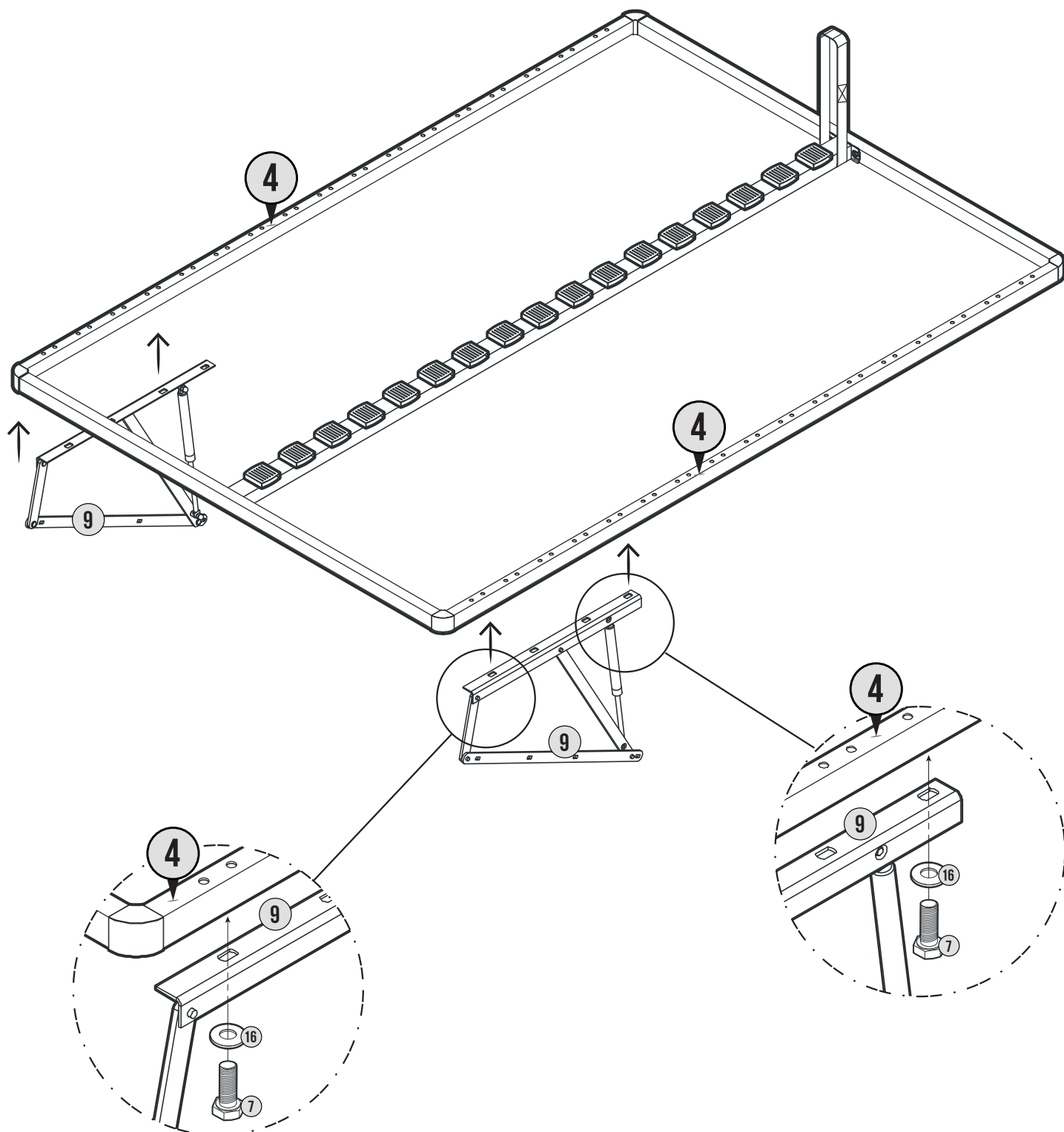

16-4 PCS



7-4 PCS

BOX 17

160523

6

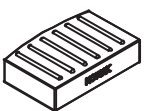
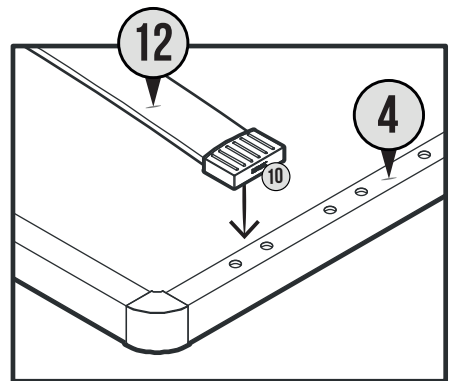
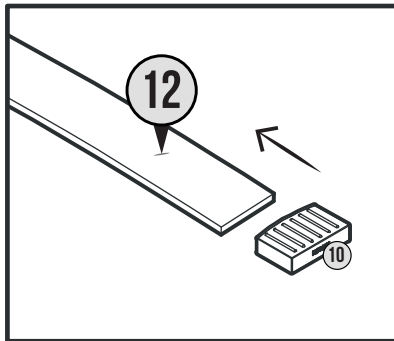
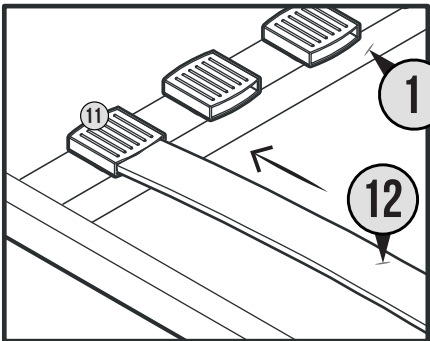
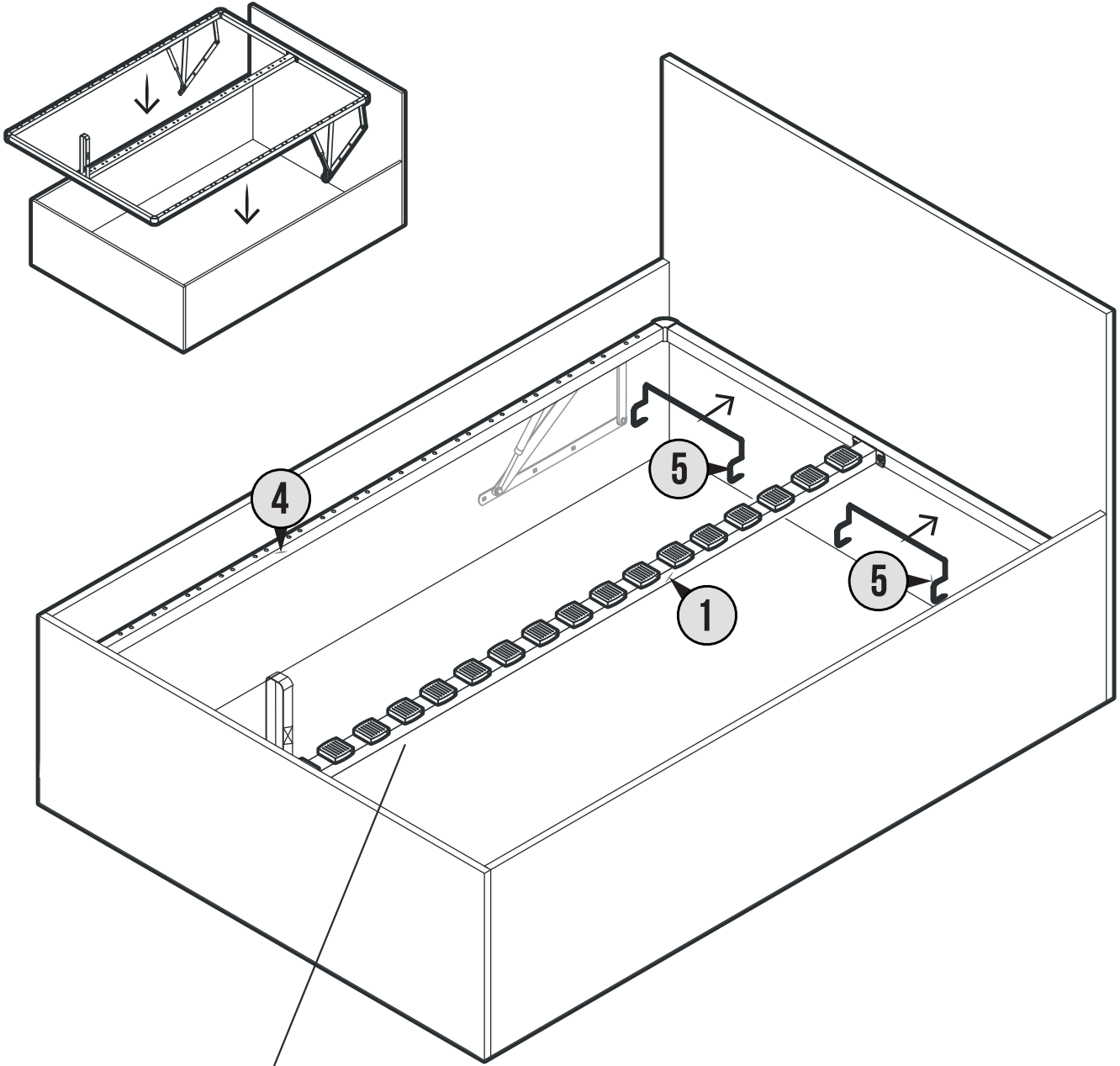

10-34 PCS

FR Description du produit

EN Product description

ES Descripción del producto

DE Produktbeschreibung

IT Descrizione del prodotto

NL Productomschrijving

PT Descrição do produto

Lit LERUCO

140x190cm / 160x200cm / 180x200cm



Vente-unique

Du bonheur à tous les étages

1. Identificare le parti che compongono il mobile.
2. Raccogliere le parti e contarle.
3. Tenere pronti gli attrezzi necessari.
4. Organizzare uno spazio per il montaggio, un telo da parete o una coperta proteggerà i mobili contro i graffi.
5. Montare il mobile, non forzare mai le parti da assemblare.



IT Serrare le viti dopo che sono state usate per un certo periodo di tempo.
Conservare le istruzioni di montaggio poiché vi torneranno utili quando ricontatterete il negozio se una parte dovesse mancare.
Si consiglia di ventilare la stanza durante l'installazione e durante le ore successive.

1. Identificeer de onderdelen waar uw stuk meubilair uit bestaat.
2. Verzamel de hardwareonderdelen en tel deze.
3. Heb het vereiste gereedschap bijdehand.
4. Organiseer een ruimte voor assemblage; muurtapijt of een deken zal het meubilair beschermen tegen krassen.
5. Monteer het meubilair en forceer hierbij nooit de te monteren onderdelen.



NL Draai de schroeven vast nadat het een tijdje in gebruik is geweest.
Bewaar de assemblage-instructies in het geval dat u contact op moet nemen met de winkel indien er een onderdeel ontbreekt.
Wij raden u aan de kamer te ventileren tijdens en voor enkele uren na de installatie.

1. Identifique as peças que constituem a sua mobília.
2. Junte as ferragens e conte.
3. Tenha prontas as ferramentas necessárias.
4. Organize e arranje espaço para a montagem, colocando um tapete ou manta para proteger a mobília contra riscos.
5. Monte a mobília, nunca force as peças a montar.



PT Aperte os parafusos após a peça de mobília ter sido utilizada durante algum tempo.
Guarde as instruções de montagem, pois serão úteis quando quiser contactar a loja, caso perca alguma peça.
Aconselhamos a ventilar a divisão durante a instalação e algumas horas depois.

**IMPORTANT, A CONSERVEZ-LES POUR UNE
REFERENCE ULTERIEURE: LIRE
ATTENTIVEMENT**

**IMPORTANT, RETAIN FOR FUTURE REFERENCE:
READ CAREFULLY**

IMPORTANTE, CONSERVAR PARA FUTURAS

CONSULTAS: LEER ATENTAMENTE





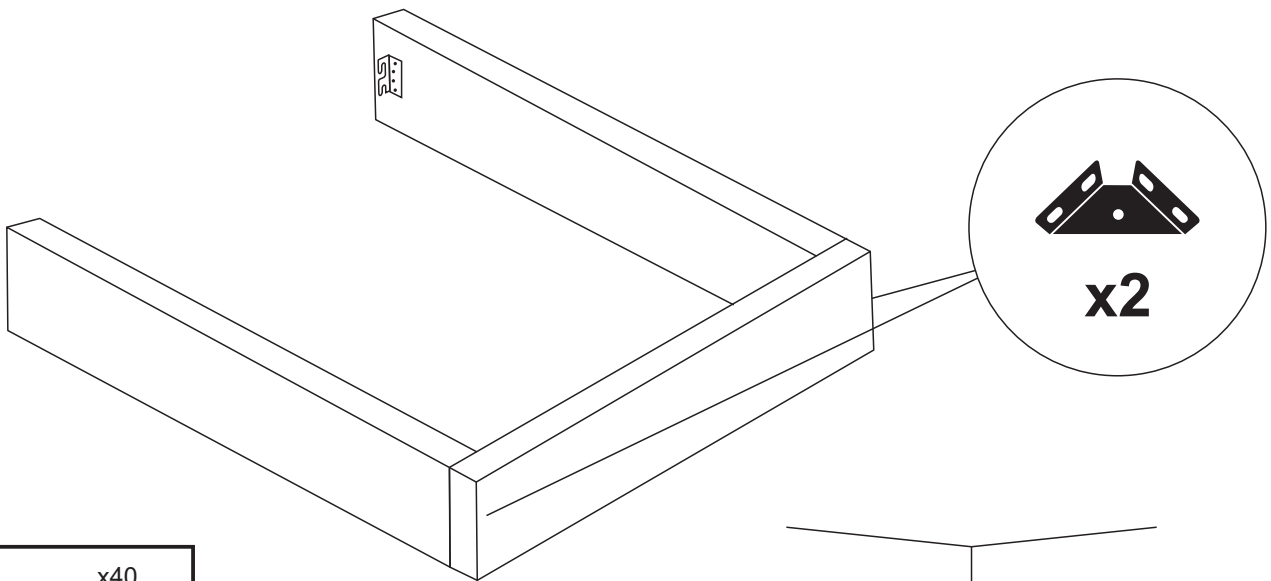
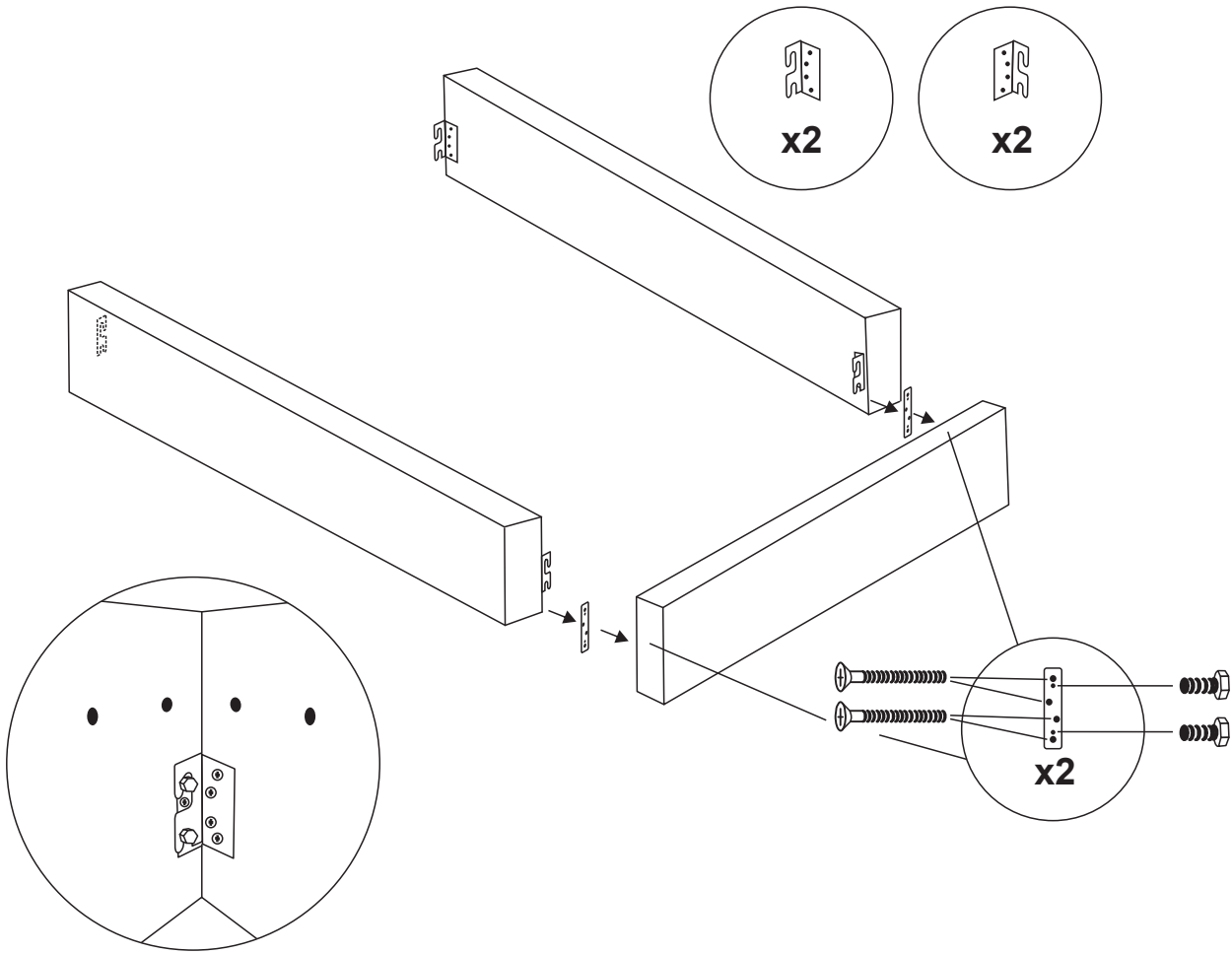

**WICHTIG, FÜR SPÄTERES NACHSCHLAGEN
AUFBEWAHREN: SORGFÄLTIG LESEN**

**IMPORTANTE, CONSERVARE PER RIFERIMENTO
FUTURO, LEGGERE CON ATTENZIONE**

**BELANGRIJK, BEWAARALS EVENTUEEL
NASLAGWERK, ZORGVULDIG LEZEN**



**IMPORTANTE, GUARDAR PARA REFERÊNCIA
FUTURA, LER ATENTAMENTE**

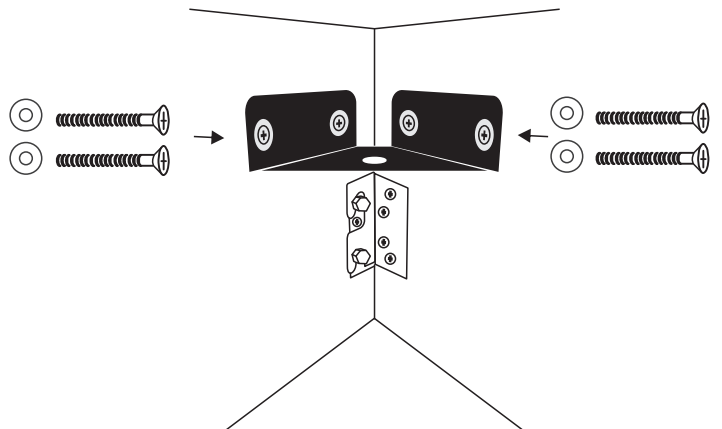

 x40 45mm	
 x8	 x4
 x16	 x2
 x4	 x2

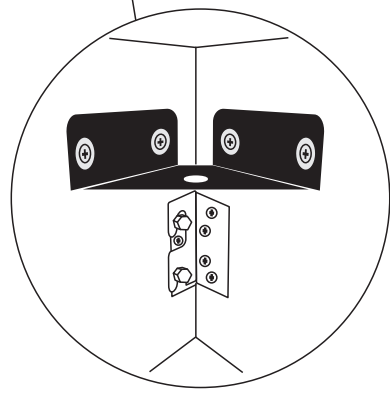
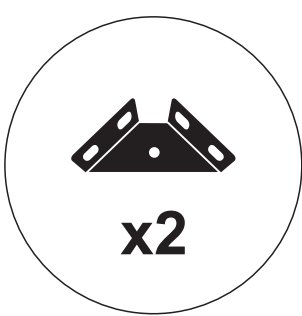
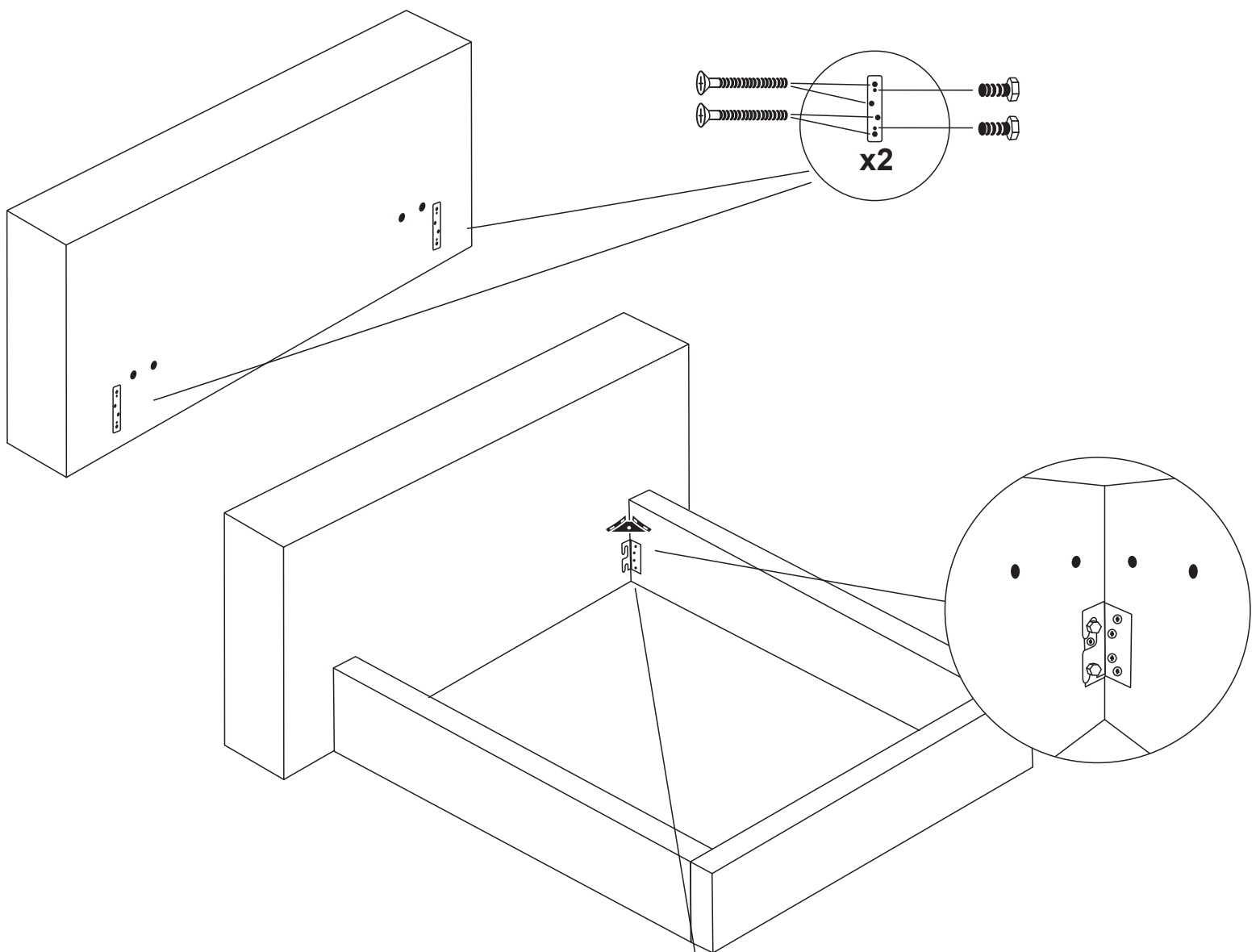



- ←  **x4**
- ←  **x4**

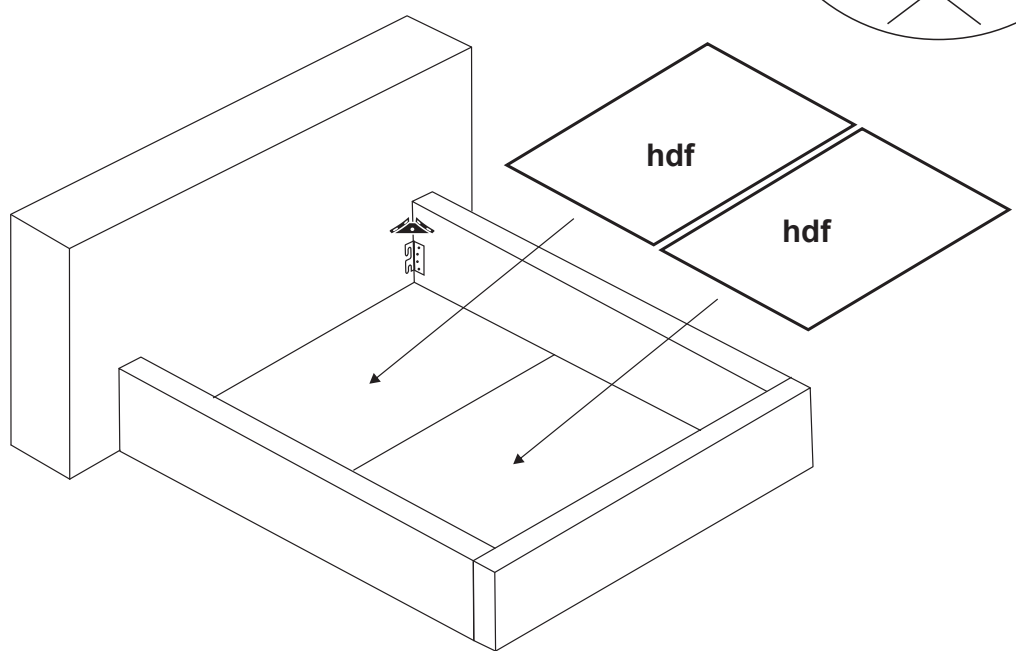

Entretien et maintenance:

Dépeussierer régulièrement avec un chiffon sec.

Nettoyer avec du liquide vaisselle et essuyer avec un chiffon humide.

Ne pas utiliser le produit si l'un des éléments semble endommagé, brisé ou manque.

Eviter de placer ce produit à proximité de feu ouvert et d'autres sources de forte chaleur telle qu'un radiateur.

Care and maintenance:

Remove dust regularly with a dry cloth.

Clean with dishwashing liquid and wipe with a damp cloth.

Do not use the product if any part appears damaged, broken or missing.

Be aware of the risk of open fire and other sources of strong heat, such as electric heaters, in the vicinity of the product.

Cuidado y mantenimiento:

Quite el polvo periódicamente con un paño seco.

Limpiar con líquido para lavar platos y limpie con un paño húmedo.

No utilice el producto si alguna de las piezas está dañada, rota o falta.

Conozca los riesgos de un fuego y de otras fuentes de calor fuerte, como los calefactores eléctricos, en las proximidades del producto.

Pflege und Wartung:

Entfernen Sie den Staub regelmäßig mit einem trockenen Tuch.

Reinigen Sie mit Spülmittel und wischen Sie mit einem feuchten Tuch.

Verwenden Sie das Produkt nicht, wenn Teile beschädigt, defekt sind oder fehlen.

Achten Sie auf die Gefahr von Feuer und anderen starken Wärmequellen in der Nähe des Produkts, wie elektrische Heizkörper.

Cura e manutenzione:

Rimuovere la polvere regolarmente con un panno asciutto.

Pulire con detersivo per piatti e asciugare con un panno umido.

Non utilizzare il prodotto se una parte risulta danneggiata, rotta o mancante.

Essere consapevoli del rischio rappresentato da un camino e da altre fonti di forte calore, come riscaldatori elettrici, in prossimità del prodotto.

Onderhoud en reiniging:

Verwijder regelmatig enigerlei stof met een droge doek.

Reinig met afwasmiddel en veeg af met een vochtig doekje.

Gebruik het product niet als enigerlei onderdelen beschadigd lijken, gebroken zijn of ontbreken.

Houd rekening met de risico's van open vuur en andere krachtige hittebronnen, zoals elektrische verwarming, in de buurt van het product.

Cuidado e manutenção:

Remova frequentemente a poeira com um pano seco.

Limpe com detergente da loiça e um pano humedecido.

Não utilize o produto se alguma peça parecer danificada, partida ou em falta.

Tenha em atenção o risco de chama viva e de outras fontes de calor forte, como aquecedores elétricos, perto do produto.



Vente-unique

Du bonheur à tous les étages

VS-Aug-2024

Imported by - Importé par

CAFOM DISTRIBUTION

9 Rue Jacquart 93310 Le Pré-Saint-Gervais

Made in Poland / Fabriqué en Pologne