

























Read this instruction carefully. See hardware and furniture part list for guidance. Be sure all parts are complete, before you assemble. Place all wooden furniture parts on a clean and flat soft surface to prevent from being scratched. Follow the figure to start assembling.

CAUTIONS : 1. Do not FULLY - TIGHTEN the nut or nut bolt until all nut or bolt is ready assembled.
 2. Do not OVER - TIGHTEN the nut or bolt to avoid causing damages to the thread.
 3. Keep all hardware parts out of reach of children.

NOTE : THE LIST AND QUANTITY SHOWN ARE FOR 1 UNIT ASSEMBLY.

Tool needed : Screwdriver & Rubber Mallet (not provider).

| PART LIST | | |
|-----------|-------------------------|--------|
| ITEM | DESCRIPTION | QTY |
| A | HEADBOARD | 1 PC |
| B | FOOTBOARD | 1 PC |
| C | SIDE RAIL | 2 PCS |
| D | BED LEG | 4 PCS |
| E | HANDLE | 2 PCS |
| F | METAL FRAME | 1 SET |
| G | PP TAPE | 1 PC |
| H | GAS SPRING | 2 PCS |
| I | METAL SUPPORT LEG | 1 PC |
| J | HORIZONTAL SUPPORT WOOD | 5 PCS |
| K | CENTER SUPPORT LEG | 5 PCS |
| L | HEADBOARD SUPPORT WOOD | 1 PC |
| M | FOOTBOARD SUPPORT WOOD | 2 PCS |
| N | BOTTOM SUPPORT BOARD | 4 PCS |
| O | BED SLAT | 34 PCS |
| P | 2 SMALL ANGLE | 2 PCS |
| Q | HEADBOARD WINGS (L & R) | 2 PCS |

| HARDWARE LIST | | |
|---------------|---|--------|
| ITEM | DESCRIPTION | QTY |
| 1 | JCBC BOLT M6 x 30mm  | 5 PCS |
| 2 | JCBC BOLT M6 x 40mm  | 6 PCS |
| 3 | JCBC BOLT M6 x 70mm  | 6 PCS |
| 4 | JCBB BOLT M8 x 40mm  | 16 PCS |
| 5 | WOOD SCREW M4 x 20mm  | 8 PCS |
| 6 | WOOD DOWEL M8 x 30mm  | 4 PCS |
| 7 | BED SLAT SIDE FITTER  | 34 PCS |
| 8 | BED SLAT CENTER FITTER  | 17 PCS |
| 9 | M4 ALLEN KEY (BALL SHAPE)  | 1 PC |
| 10 | M5 ALLEN KEY (BALL SHAPE)  | 1 PC |
| 11 | JCBC BOLT M6 x 40mm  | 6 PCS |
| 12 | JCBB BOLT M8 x 70mm  | 8 PCS |
| 13 | M6 FLAT WASHER  | 12 PCS |
| 14 | M6 SPRING WASHER  | 6 PCS |
| 15 | M8 FLAT WASHER  | 20 PCS |
| 16 | M8 SPRING WASHER  | 20 PCS |
| 17 | M6 HEX NUT  | 6 PCS |
| 18 | M8 HEX NUT  | 16 PCS |
| 19 | SPANNER (10mm)  | 1 PC |
| 20 | SPANNER (13mm)  | 1 PC |
| 21 | SPECIAL HEX NUT  | 2 PCS |
| 22 | JCBC BOLT M8 x 20mm  | 4 PCS |
| 23 | HANDLE SCREW M8 x 70mm  | 2 PCS |
| 24 | M8 PLASTIC COVER  | 8 PCS |
| 25 | PLASTIC WASHER  | 4 PCS |

STEP 1

Take out HEADBOARD WING (Q) from the HEABBOARD (A).

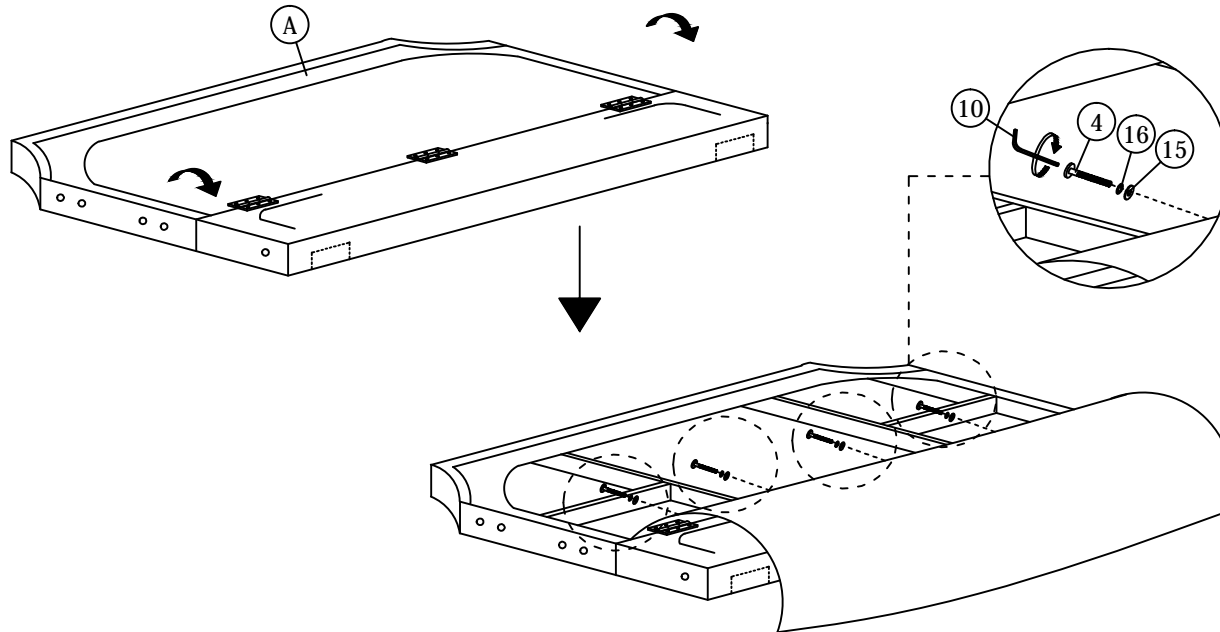

ASSEMBLY INSTRUCTIONS

STEP 2

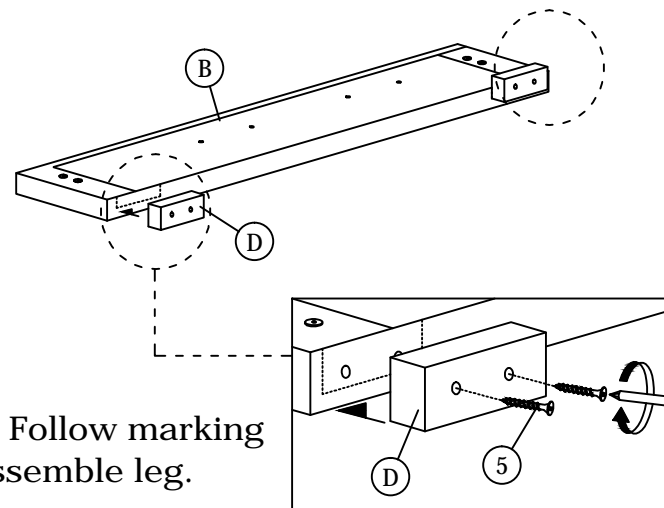
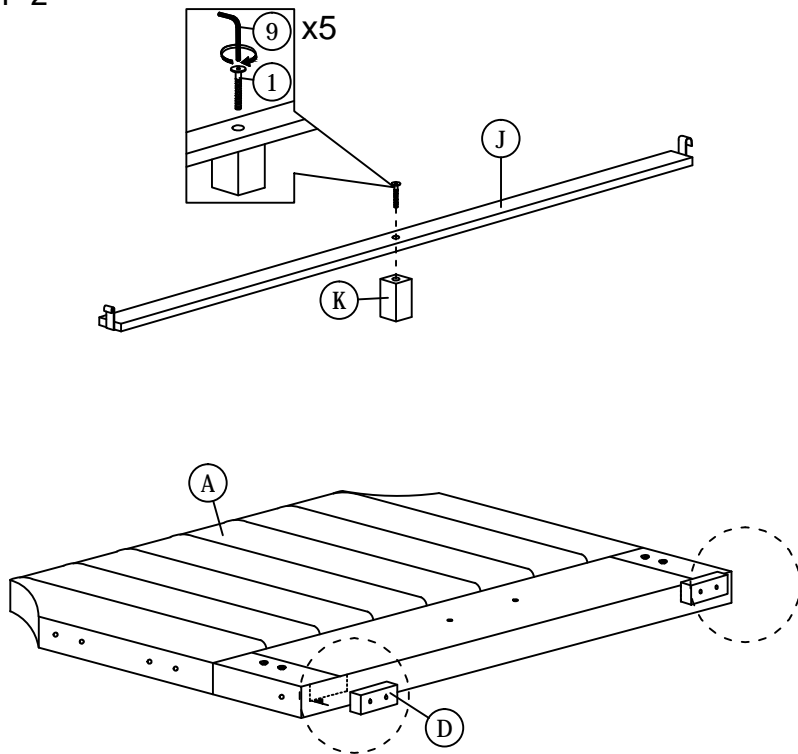

Note : Follow marking line assemble leg.

STEP 3

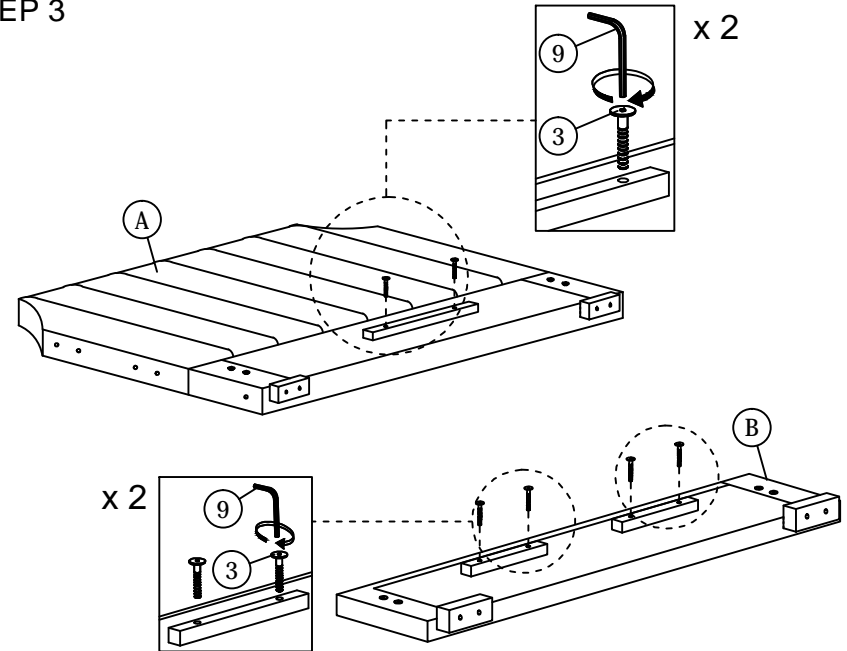

STEP 4

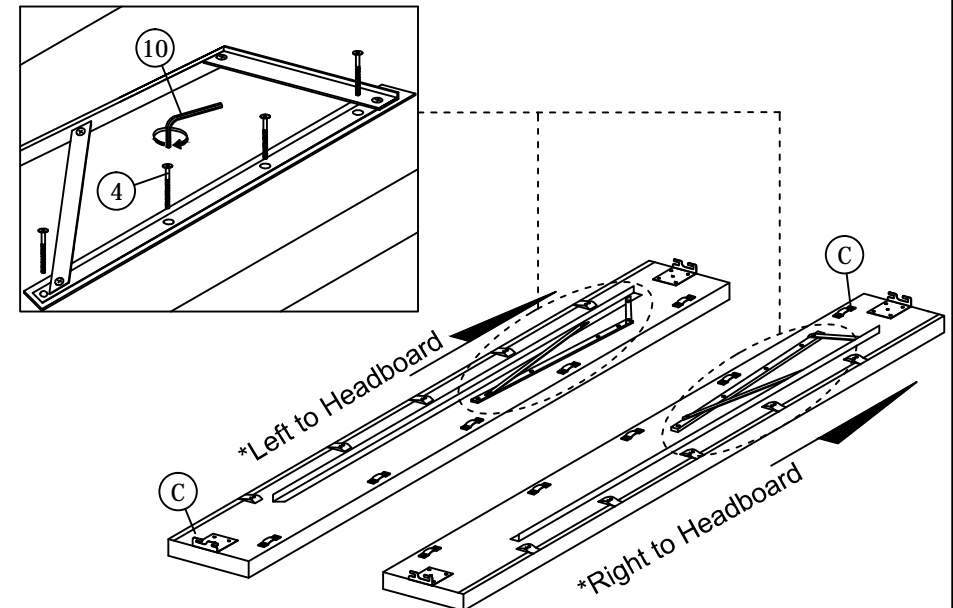

ASSEMBLY INSTRUCTIONS

STEP 5

STEP 5.1

Loosen the pre-inserted bolt on the Headboard & Footboard using Allen key ball shape (10).

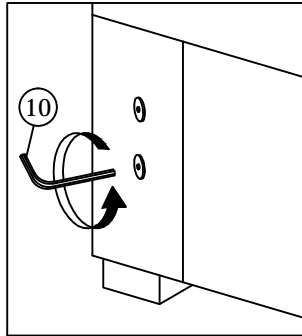

STEP 5.2

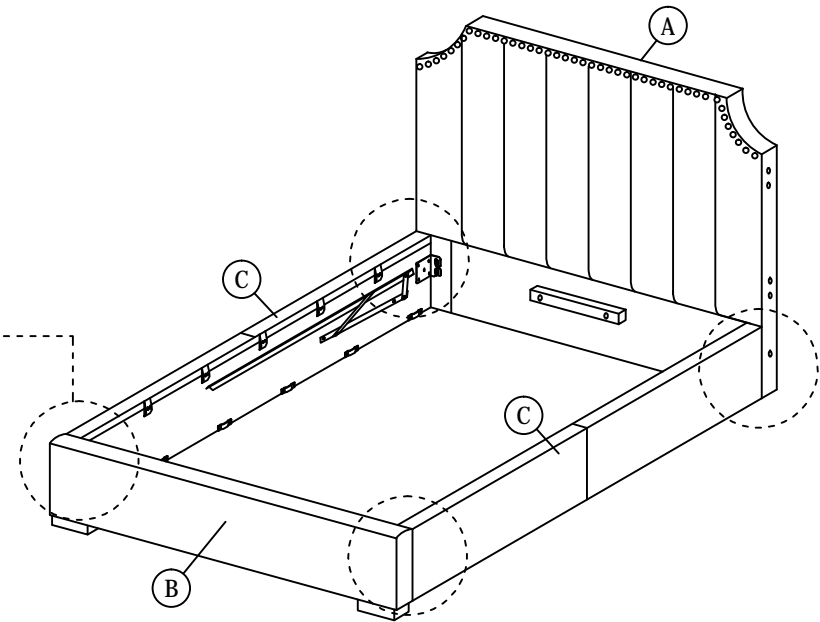
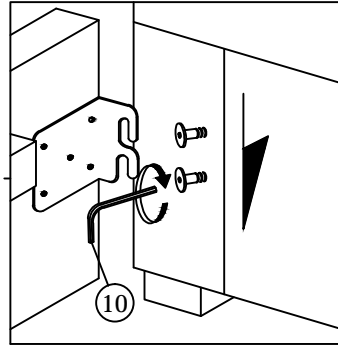

STEP 6

STEP 6.1

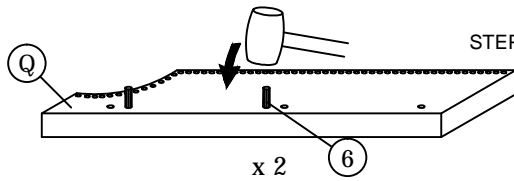

x 2 (6)

STEP 6.2

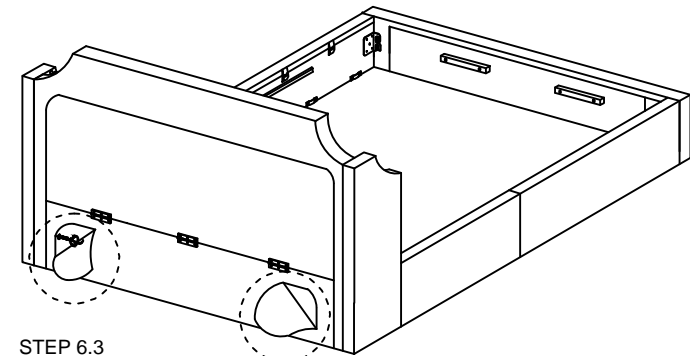
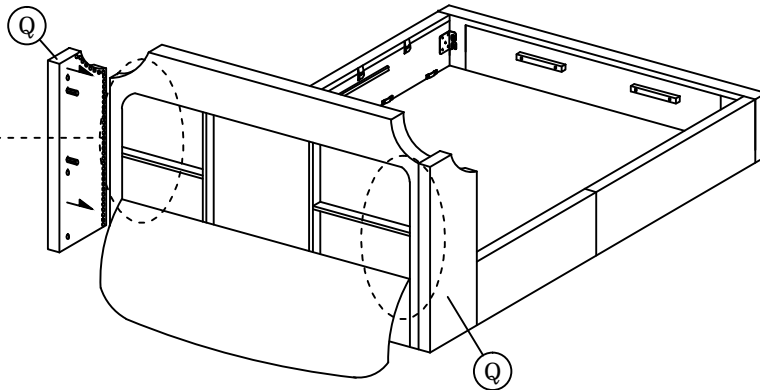
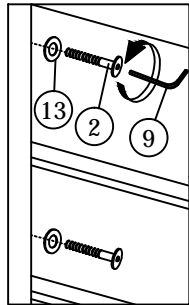

STEP 6.3

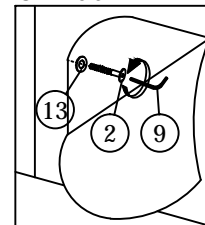

ASSEMBLY INSTRUCTIONS

STEP 7

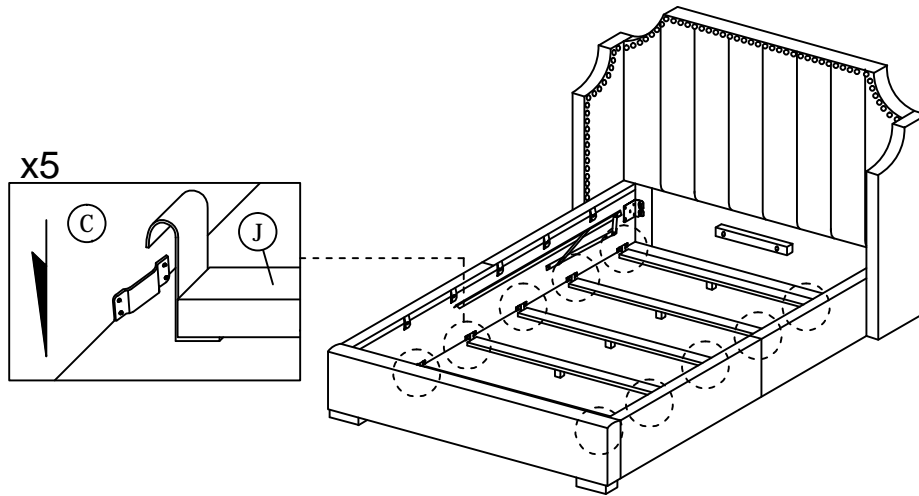

STEP 8

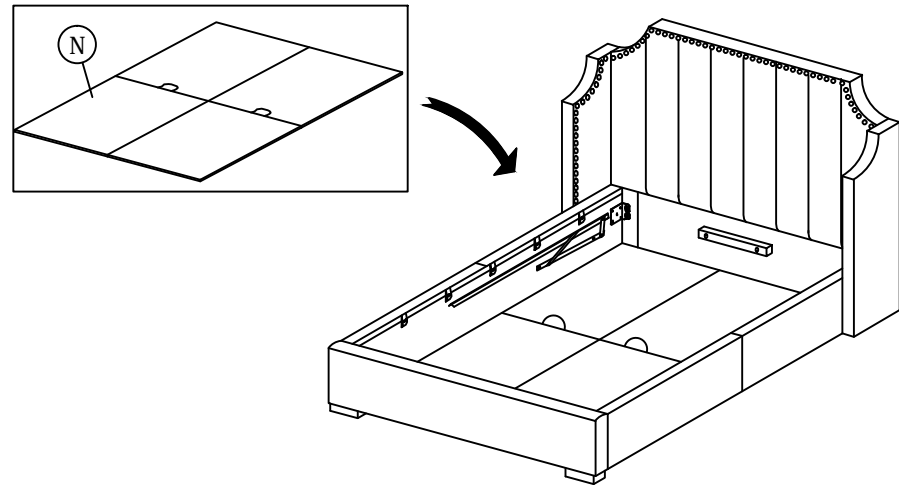

STEP 9

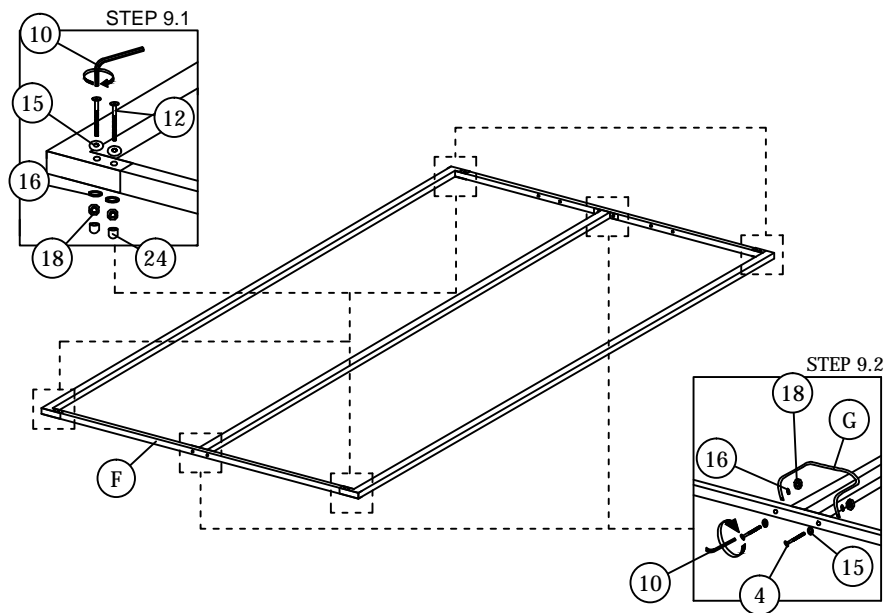

STEP 10

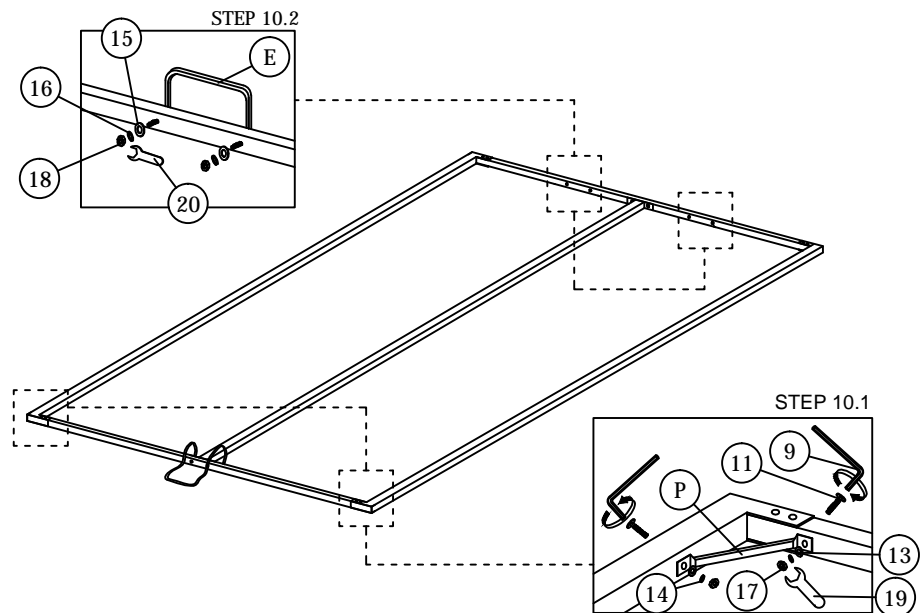

ASSEMBLY INSTRUCTIONS

STEP 11

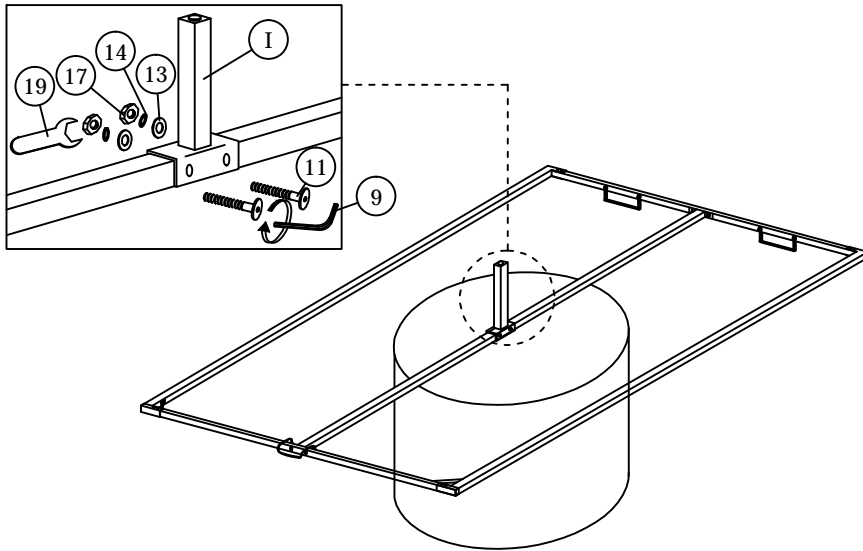

STEP 12

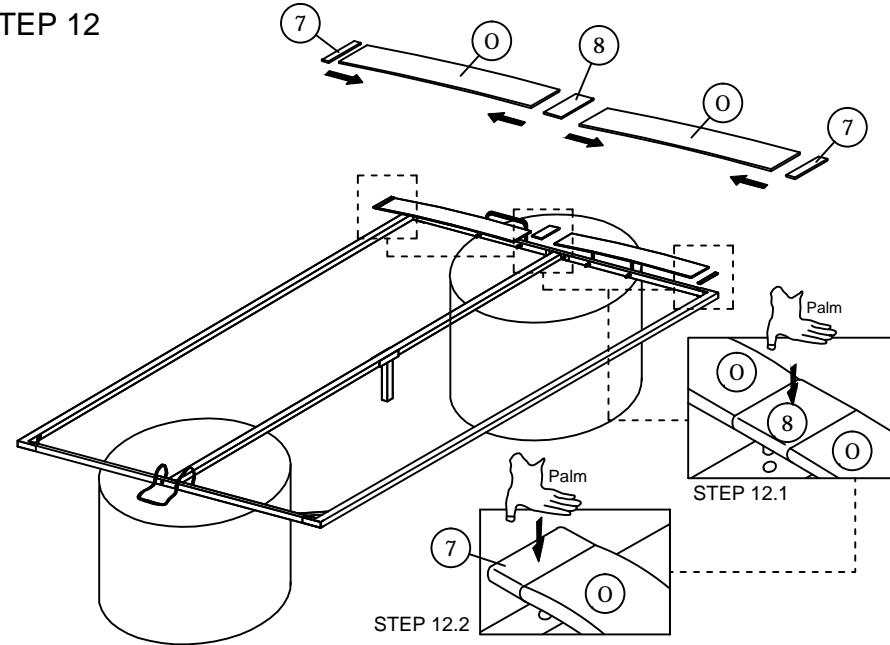

STEP 13

Attention :
A person need to hold up the metal frame from footboard side, and the other person assemble the gas spring (Item H).

Loosen the pre-inserted Special Hex Nut on the side rail metal (C) using Spanner 13mm (20).

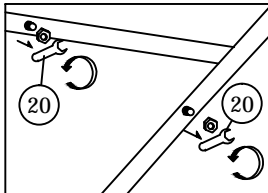

STEP 13.1

STEP 13.2

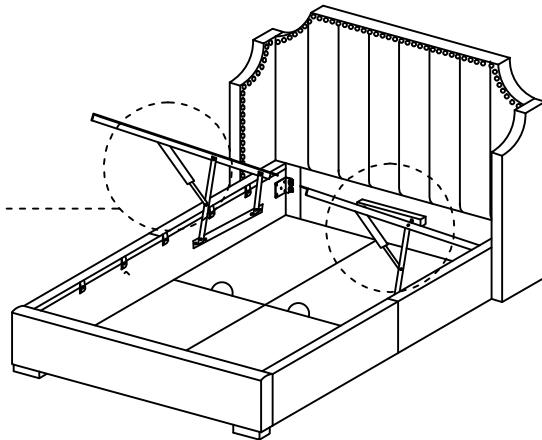
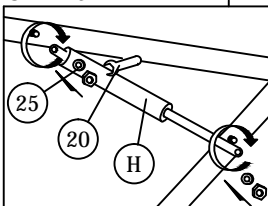

STEP 14

Note : This step requires two people.

STEP 14.1

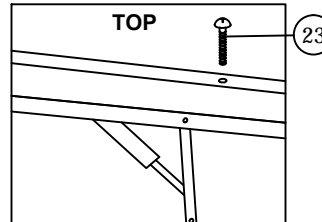

STEP 14.2

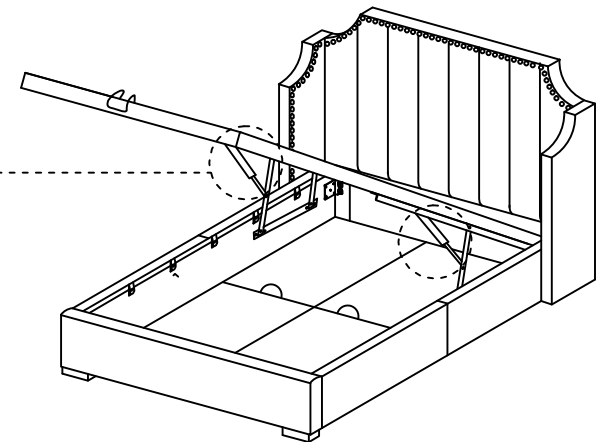
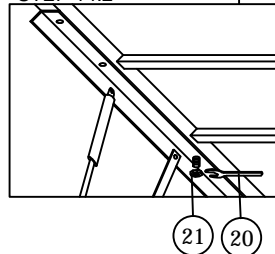

ASSEMBLY INSTRUCTIONS

STEP 15

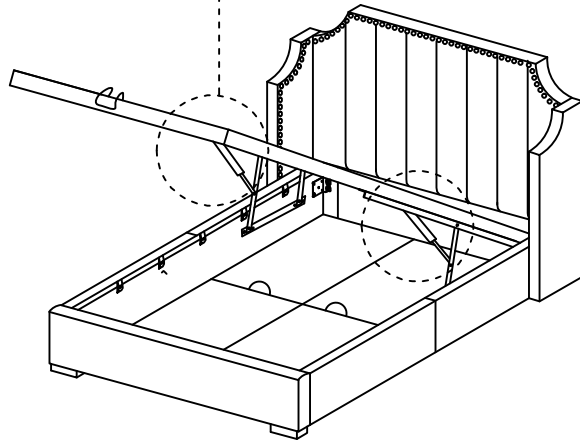
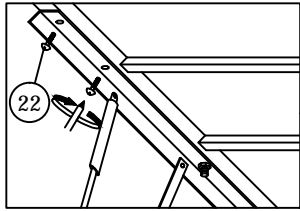

STEP 16

Attention :

1. This queen size bed supports mattress weight 50 - 70kgs.

2. Place your mattress onto the bed frame BEFORE closing or this could result in damage to the bed (MATTRESS NOT INCLUDED) .

3. It is imperative that the bed is aligned squarely to prevent the frame from catching on and damaging the upholstered side rails
Please use extra caution when opening and closing the bed for the first few times.

Ensure a similar spacing on each side of the frame.

Ensure open and close the bed frame thru center of bed by using PP tape thru center of metal frame.

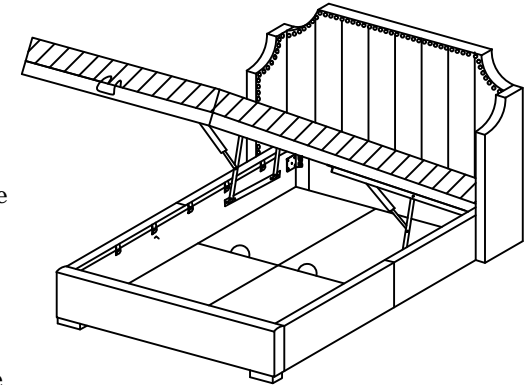

STEP 17

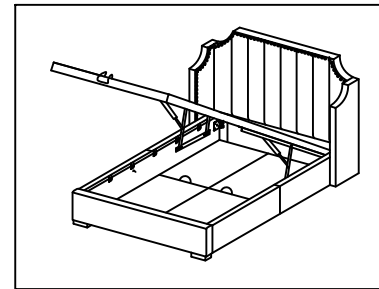
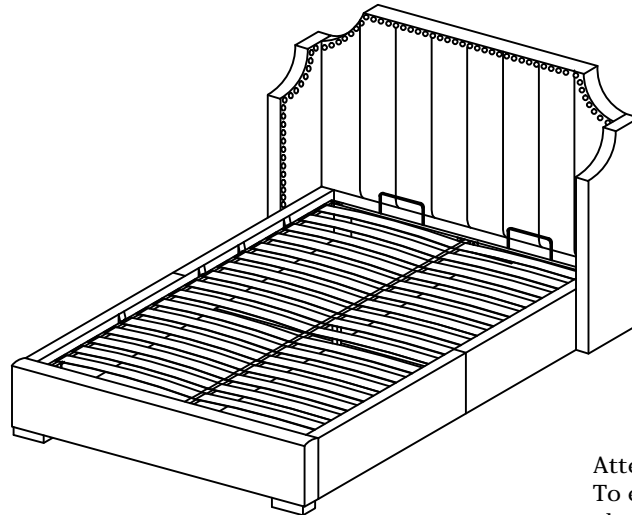

Attention :

To ensure your bed frame remains in optimum condition, please periodically check all the screw and re-tightening if necessary.