

Einbauanleitung Installation Instruction

N621P428638

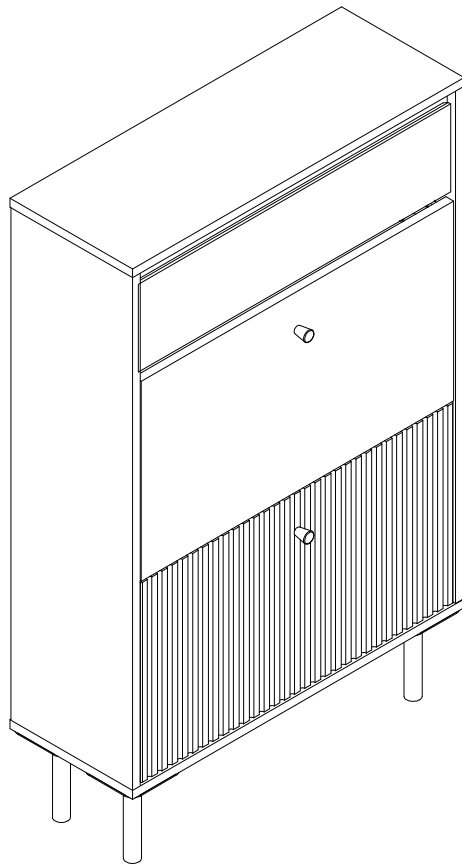

EN

Dear customer,
Thank you for purchasing this product. So that your appliance serves you well, please read all the instructions in this user's manual. If you have any questions, please contact our customer care center.

FR

Cher client,
Nous vous remercions d'avoir acheté ce produit. Afin que vous puissiez profiter pleinement de votre appareil, veuillez lire toutes les instructions de ce manuel d'utilisation. Si vous avez la moindre question, veuillez contacter notre centre d'assistance à la clientèle.

DE

Sehr geehrter Kunde,
Vielen Dank, dass Sie dieses Produkt erworben haben. Damit Ihr Gerät Ihnen gute Dienste leistet, lesen Sie bitte alle Hinweise in diesem Benutzerhandbuch. Wenn Sie Fragen haben, wenden Sie sich bitte an unser Kundendienstzentrum.

ES

Queridos clientes,
Gracias por comprar este producto. Para que su electrodoméstico le sirva mejor, lea todas las instrucciones de este manual del usuario. Si tiene alguna pregunta, comuníquese con nuestro Centro de Atención al Cliente.

IT

Caro Cliente,
Grazie per aver acquistato questo prodotto. Per servirti meglio con questo apparecchio ti prego di leggere tutte le istruzioni in presente manuale utente. In caso di dubbio, si prega di contattare il nostro centro assistenza clienti.

USING CAM LOCK AND QUICKFIT

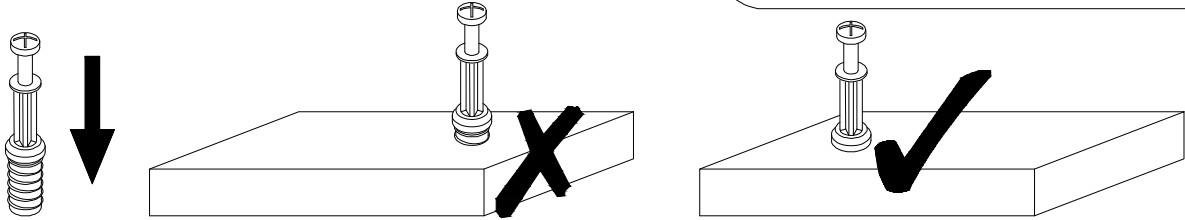

EN QUICKFIT: Tighten quickfit until shoulder is flush with panel. Do not overtighten or undertighten.

FR RACCORD RAPIDE: Faites serrer le raccord rapide jusqu'à ce que l'épaulement soit parfaitement encastré dans le panneau. Il ne faut ni trop serrer ni insuffisamment serrer.

ES QUICKFIT: Apriete quickfit hasta que el hombro se descargue con el panel. NO lo sobreapriete ni lo apriete poco.

DE QUICKFIT: Ziehen Sie den Quickfit fest, bis die Schulter mit der Platte bundig ist. Bitte nicht zu fest oder zu schwach anziehen.

IT_MONTAGGIO RAPIDO: Stringere il montaggio rapido fino a quando la spalla è a filo con il pannello, non stringere troppo o troppo poco.

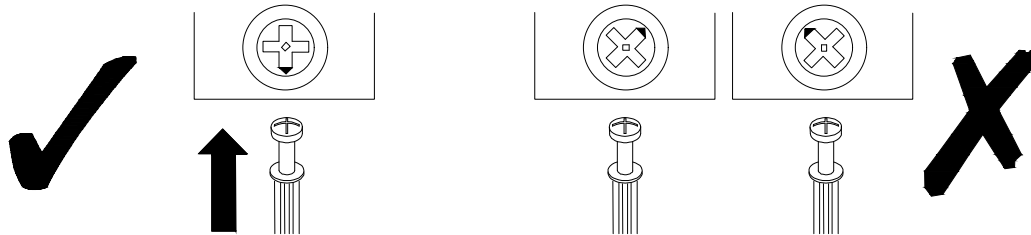

EN CAM LOCK: When fitting cam lock, ensure starting position is correct before you insert connecting quickfit.

FR SERRURE BATTEUSE: Avant d'insérer la serrure batteuse, veillez à la bonne orientation avant d'insérer le raccord rapide.

ES CIERRE DE LA CAMARA: Cuando instale el cierre de la cámara, asegúrese de que la posición de inicio es correcta antes de que inserte el quickfit conector.

DE_CAM-LOCK: Achten Sie bei der Montage des Cam-Locks auf die richtige Ausgangsposition, bevor Sie den Quickfit einsetzen.

IT_BLOCCAGGIO A CAMMA: Quando si monta il bloccaggio a camma, assicurarsi che la posizione iniziale sia corretta prima di inserire il montaggio rapido di collegamento.

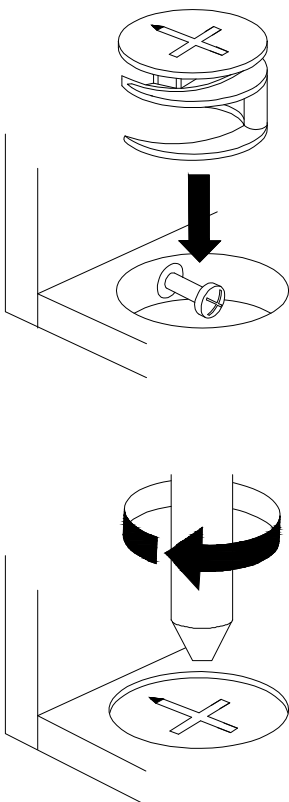

EN Quickfit head should be in the centre of the cam lock when the two panels are joined.

Cam lock should be inserted before quickfit.

FR_Lorsque les deux panneaux sont assemblés, la tête du raccord rapide doit reposer au centre de la serrure batteuse.

Il faut insérer la serrure batteuse avant le raccord rapide.

ES_El cabezal del quickfit debe estar en el centro del cierre de la cámara cuando se unan los dos paneles.

Se debe insertar el cierre de la cámara antes del quickfit.

DE_Der Quickfit-Kopf sollte sich in der Mitte des Cam-Locks befinden, wenn die beiden Platten zusammengefügt sind.

Der Cam-Lock sollte vor dem Quickfit eingesetzt werden.

IT_La testa del montaggio rapido deve trovarsi al centro del bloccaggio a camma quando i due pannelli sono uniti.

Il Bloccaggio a Camma deve essere inserito prima del montaggio rapido.

Il Bloccaggio a Camma deve essere inserito prima del montaggio rapido.

EN Turn cam lock clockwise to tighten.

FR Faites tourner la serrure batteuse dans le sens des aiguilles d'une montre pour la resserrer.

ES Gire el cierre de la cámara en sentido horario para apretarlo.

DE Drehen Sie den Cam-Lock im Uhrzeigersinn, um ihn festzuziehen.

IT Ruotare il bloccaggio a camma in senso orario per stringere.

Importeur	Decobus Handel GmbH
Adresse	Innungsstraße 9, 21244 Buchholz, Deutschland
URL	https://www.decobusgroup.de
Hersteller	Shouguang Rema Wood Co., LTD
Adresse	Daotian Town, Shouguang City, Weifang, shandong, China
Email/URL	https://www.remawood.com
Partienummer	N621P428638
Hergestellt in	China
	<p>Decobus Handel GmbH Innungsstraße 9,21244 Buchholz,Deutschland https://www.decobusgroup.de</p>

GB-Anchor unit to stud or wall.

DO NOT allow children to climb on unit.

Always use on a level, even surface.

Always lift the item with two people to reposition.

DO NOT place the item next to a radiator or direct sunlight.

DO NOT place hot or cold items directly onto the surface.

DO NOT put the product in a humid environment.



FR-Fixer l'appareil à un montant ou à un mur.

NE PAS laisser les enfants grimper sur l'appareil.

Toujours utiliser l'appareil sur une surface plane et régulière.

Toujours soulever l'article à deux pour le repositionner.

NE PAS placer l'article à côté d'un radiateur ou de la lumière directe du soleil.

NE PAS placer d'objets chauds ou froids directement sur la surface.

NE PAS placer le produit dans un environnement humide.

IT-Ankorare l'unità a un pilastro o a una parete.

NON permettere ai bambini di arrampicarsi sull'unità.

Utilizzare sempre su una superficie piana e uniforme.

Sollevarre sempre l'articolo con due persone per riposizionarlo.

NON posizionare l'articolo vicino a un radiatore o alla luce diretta del sole.

NON collocare oggetti caldi o freddi direttamente sulla superficie.

NON collocare il prodotto in un ambiente umido.

DE-Verankern Sie das Gerät an einem Ständer oder einer Wand.

Erlauben Sie Kindern NICHT, auf das Gerät zu klettern.

Benutzen Sie das Gerät immer auf einer ebenen, glatten Fläche.

Heben Sie das Gerät immer mit zwei Personen an, um es neu zu positionieren.

Stellen Sie das Gerät NICHT in der Nähe eines Heizkörpers oder in direktem Sonnenlicht auf.

Stellen Sie KEINE heißen oder kalten Gegenstände direkt auf die Oberfläche.

Stellen Sie das Produkt NICHT in einer feuchten Umgebung auf.

ES-Ancler la unidad a un montante o pared.

NO permita que los niños se suban a la unidad.

Utilícelo siempre sobre una superficie plana y nivelada.

Levante siempre el artículo con dos personas para recolocarlo.

NO coloque el artículo cerca de un radiador o de la luz solar directa.

NO coloque objetos calientes o fríos directamente sobre la superficie.

NO coloque el producto en un ambiente húmedo.

NON collocare il prodotto in un ambiente umido.

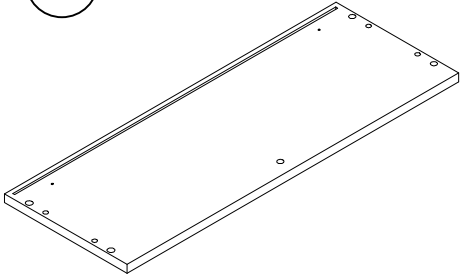
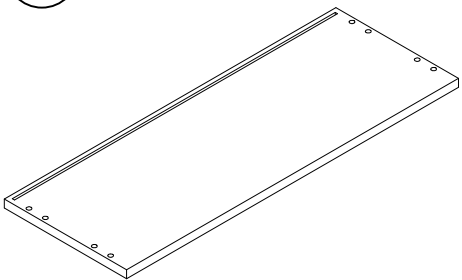
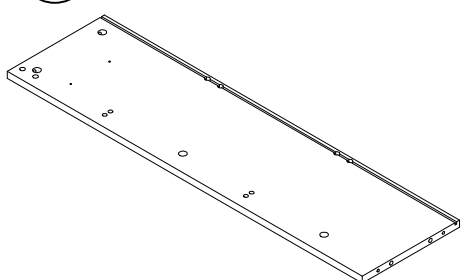
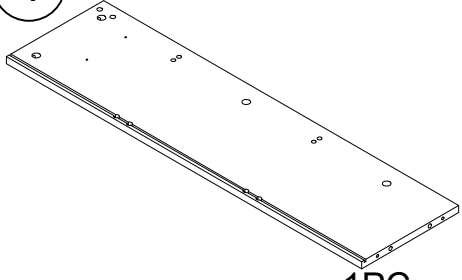
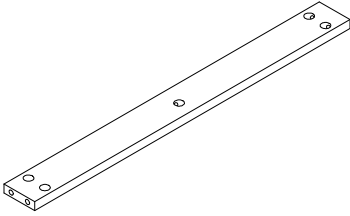
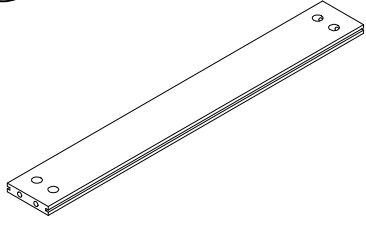
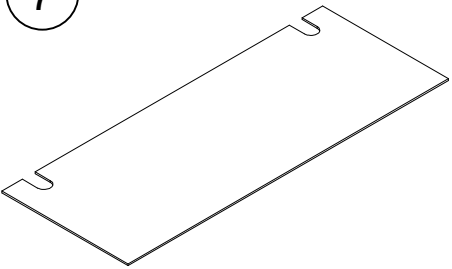
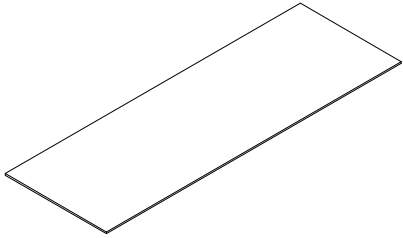
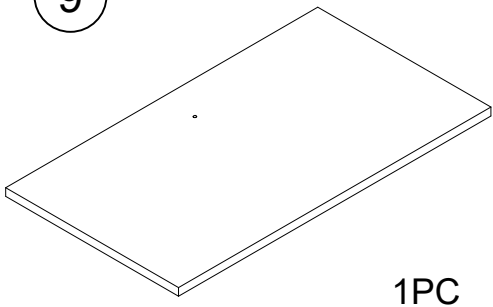
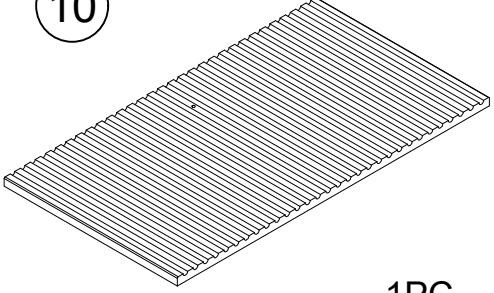
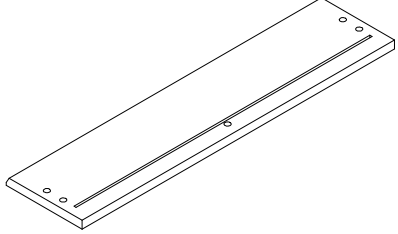
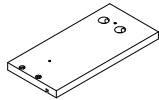
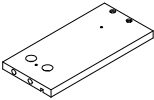
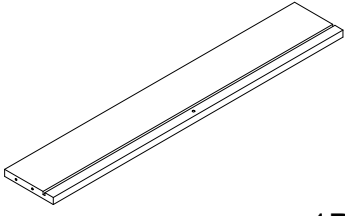
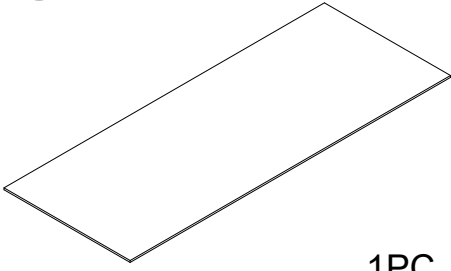
<p>①</p>  <p>1PC</p>	<p>②</p>  <p>1PC</p>	<p>③</p>  <p>1PC</p>
<p>④</p>  <p>1PC</p>	<p>⑤</p>  <p>1PC</p>	<p>⑥</p>  <p>2PCS</p>
<p>⑦</p>  <p>1PC</p>	<p>⑧</p>  <p>2PCS</p>	<p>⑨</p>  <p>1PC</p>
<p>⑩</p>  <p>1PC</p>	<p>⑪</p>  <p>1PC</p>	<p>⑫</p>  <p>1PC</p>
<p>⑬</p>  <p>1PC</p>	<p>⑭</p>  <p>1PC</p>	<p>⑮</p>  <p>1PC</p>

16

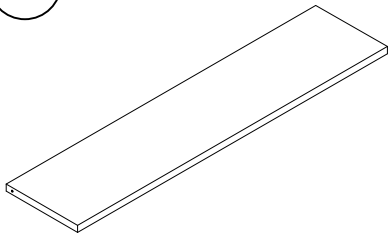

4PCS

17

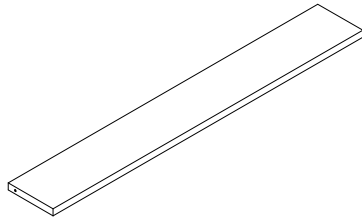

2PCS

18

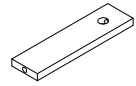

1PC

Hardware Box

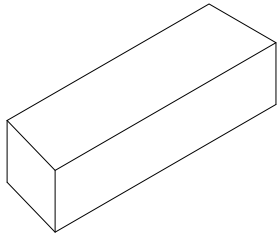

Montage Assembling

Geschätzte Zeit für die Montage

Estimated time for assembly



55 : 00

Was Sie brauchen

What you need

- Verwenden Sie den Verpackungskarton als Arbeitsfläche, um Produktschäden während der Montage zu vermeiden
- Kreuzschlitzschraubendreher
- Use the packaging carton as a working surface to prevent product damage during assembly
- Phillips head screwdriver

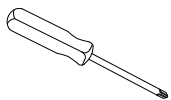

Was ist enthalten What's included

Nr.	Beschreibung	Menge
Code	Description	Qty
A		22
B		8
C		4
D		2
E		4
F		5
G		2
H		22
I		2
J		2
K		4
L		4
M		62
N		2
O		4
P		2
Q		18
R		1

Gewichtsbeschränkung

Weight Limitation



50 | 20

kgs Tischplatte kgs pro Regal
kgs table top kgs per shelf









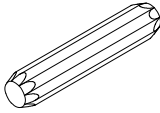
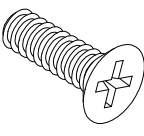
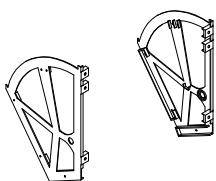

2 PERSONEN

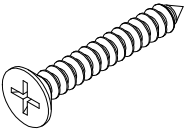
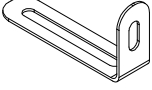
2 PERSONS

Die Hardware

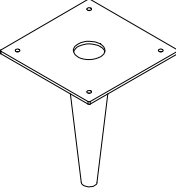
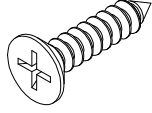
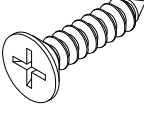
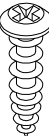
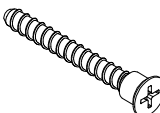
The Hardwares

<p>A</p>  <p>A1 A2</p> <p>$\Phi 6 \times 40$ 22PCS</p>	<p>B</p>  <p>$\Phi 8 \times 40$ 8PCS</p>	<p>C</p>  <p>$\Phi 3.5 \times 14$ 4PCS</p>	<p>D</p>  <p>D1 D2</p> <p>2PCS</p>
<p>E</p>  <p>E1 E2 E3</p> <p>4PCS</p>	<p>F</p>  <p>$\Phi 3.5 \times 35$ 5PCS</p>	<p>G</p>  <p>2PCS</p>	<p>H</p>  <p>22PCS</p>
<p>I</p>  <p>$\Phi 4 \times 18$ 2PCS</p>	<p>J</p>  <p>2PCS</p>	<p>K</p>  <p>4PCS</p>	<p>L</p>  <p>$\Phi 3.5 \times 12$ 4PCS</p>
<p>M</p>  <p>$\Phi 3.5 \times 14$ 62PCS</p>	<p>N</p>  <p>$\Phi 3.5 \times 14$ 2PCS</p>	<p>O</p>  <p>$\Phi 7 \times 50$ 4PCS</p>	<p>P</p>  <p>P1 P2</p> <p>2PCS</p>

WICHTIG:

1. ziehen sie die bolzen/schrauben nicht vollständig an, bis alle bolzen/schrauben ausgerichtet und in die löcher eingesetzt sind
2. schrauben und bolzen nicht zu fest anziehen, um ein ablösen zu vermeiden.
3. bitte verwenden sie handwerkzeuge, um dieses produkt zusammenzubauen. verwenden sie keine elektrowerkzeuge.

IMPORTANT:

1. do not tighten bolts / screws completely until all bolts / screws are lined up and inserted into holes.
2. do not over tighten screws and bolts to avoid stripping.
3. please use hand tools to assemble this product. do not use power tools.



Die Hardware

The Hardwares

Q



18PCS

R

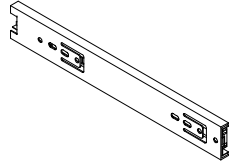

1PC

WICHTIG:

1. ziehen sie die bolzen/schrauben nicht vollständig an, bis alle bolzen/schrauben ausgerichtet und in die löcher eingesetzt sind
2. schrauben und bolzen nicht zu fest anziehen, um ein ablösen zu vermeiden.
3. bitte verwenden sie handwerkzeuge, um dieses produkt zusammenzubauen. verwenden sie keine elektrowerkzeuge.

IMPORTANT:

1. do not tighten bolts / screws completely until all bolts / screws are lined up and inserted into holes.
2. do not over tighten screws and bolts to avoid stripping.
3. please use hand tools to assemble this product. do not use power tools.



2 PERSONEN
2 PERSONS

Enthaltenes Zubehör Included Accessories

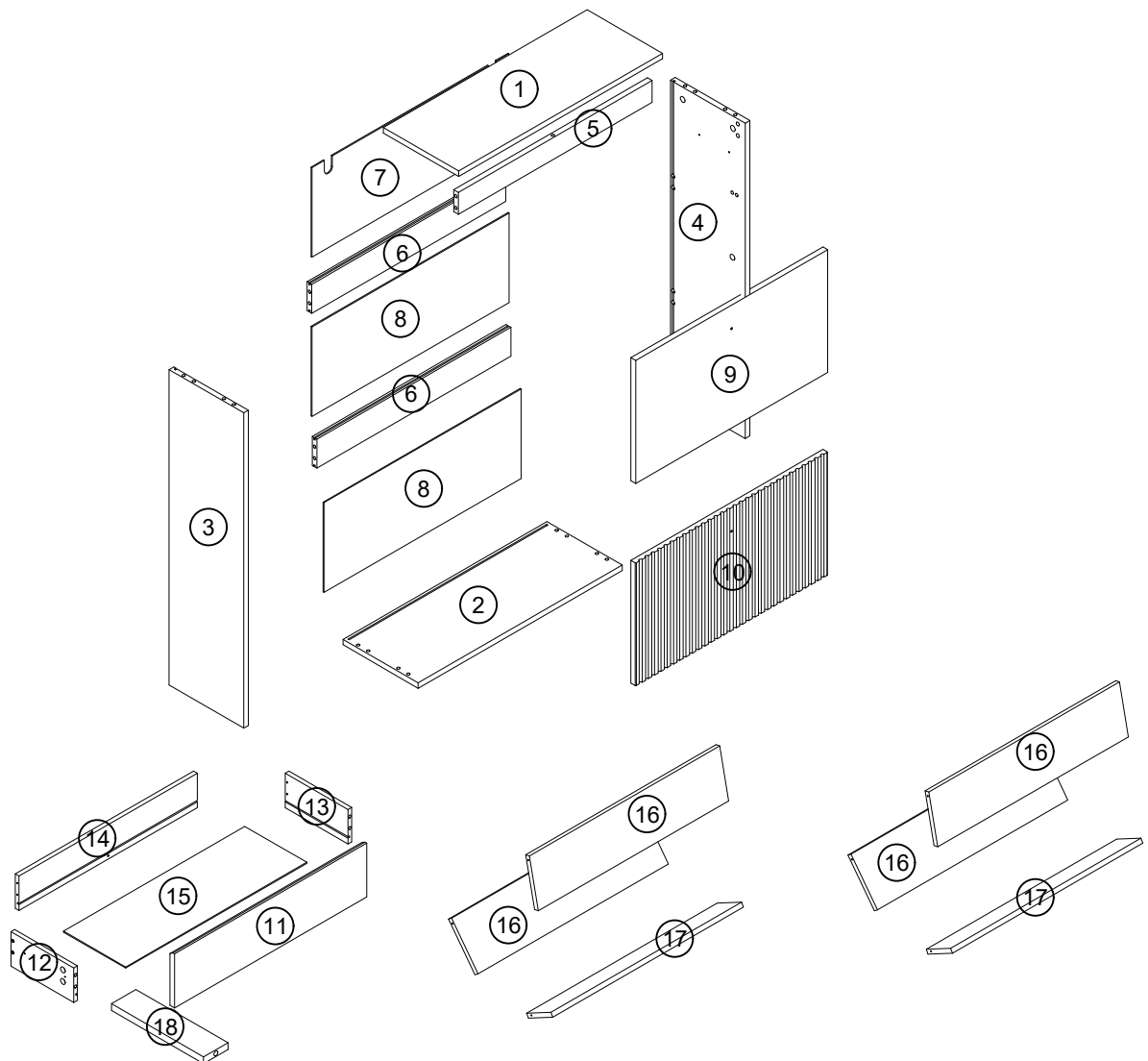

Schritt 1

Step 1

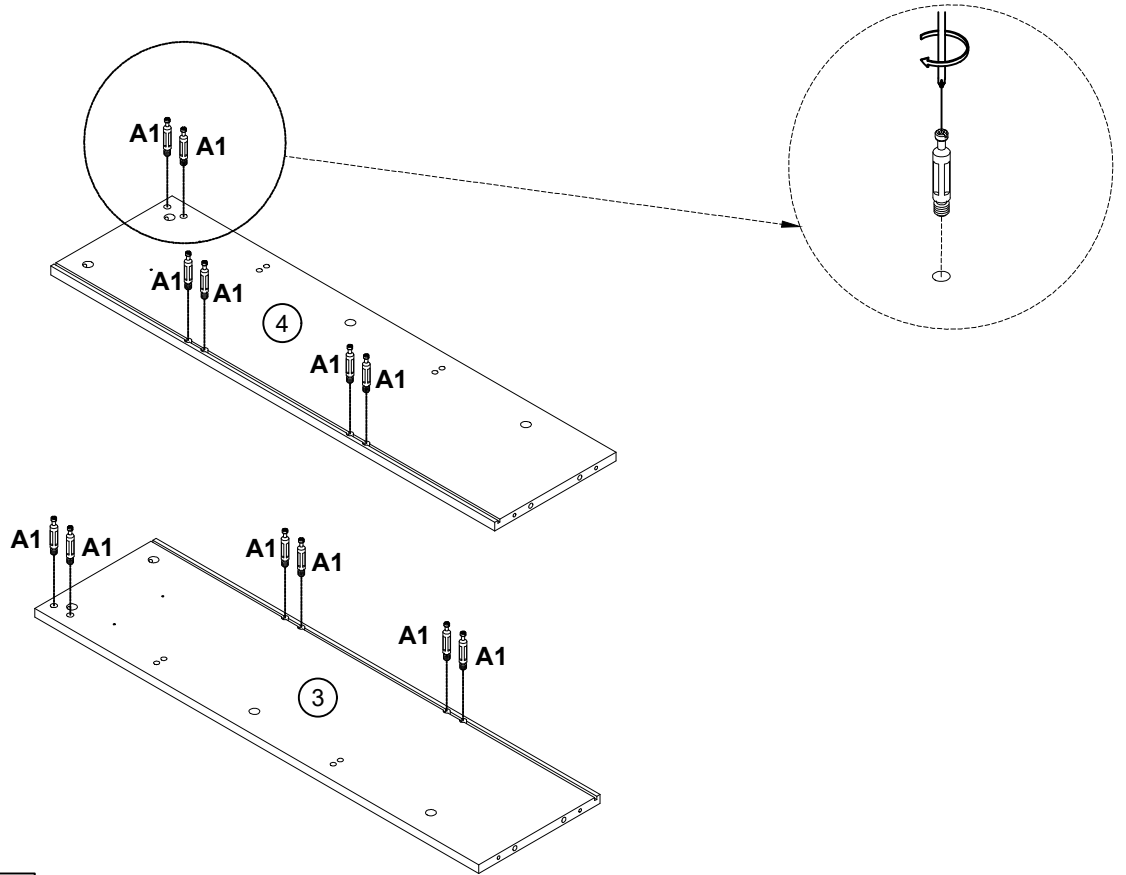

A1x12pcs

Schritt 2

Step 2

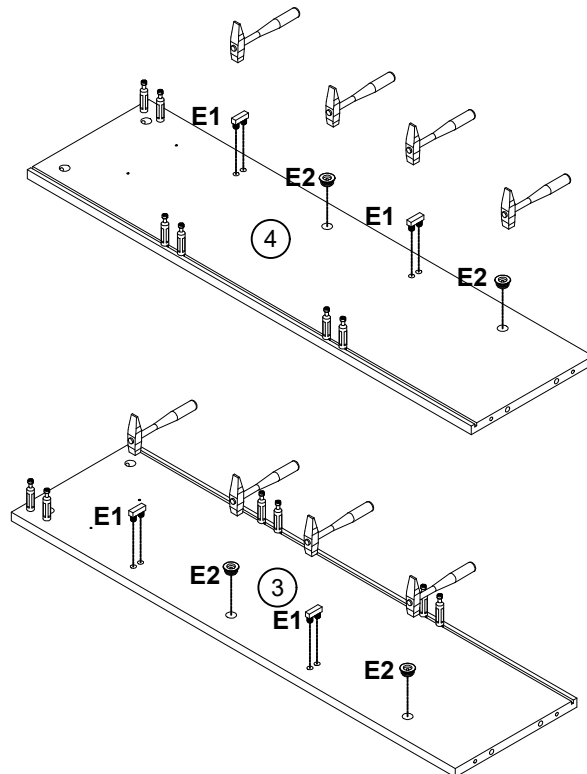



E1x4pcs

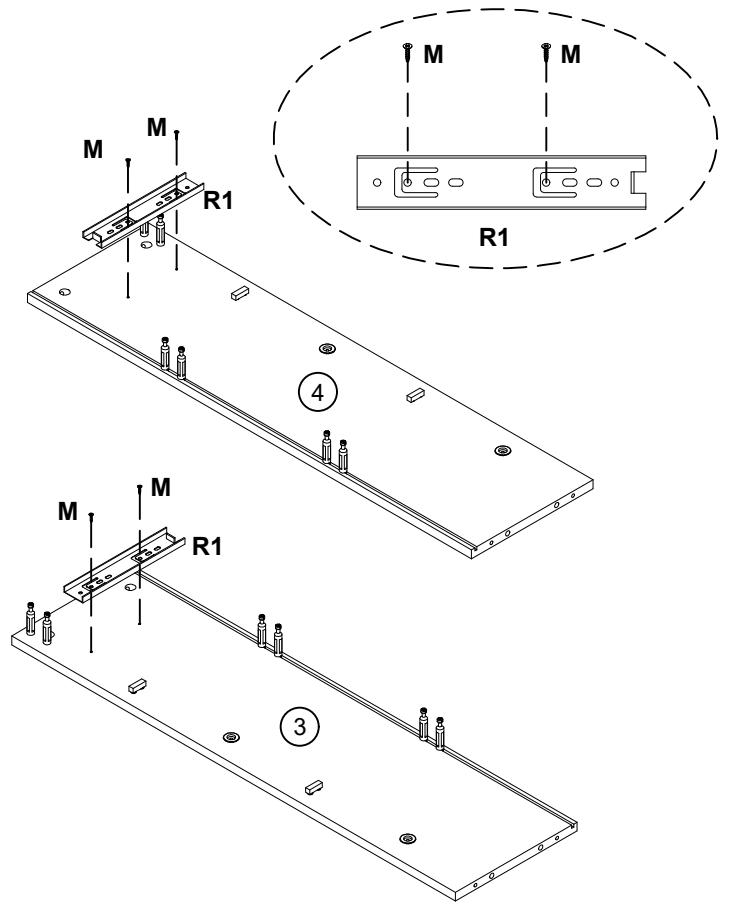
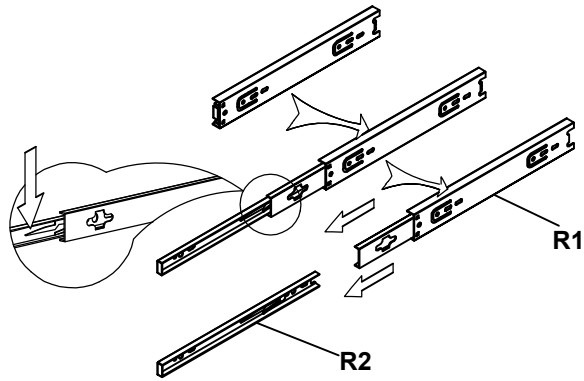

E2x4pcs

Schritt 3 Step 3

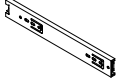

	Mx4pcs
	Rx1pc

Schritt 4 Step 4

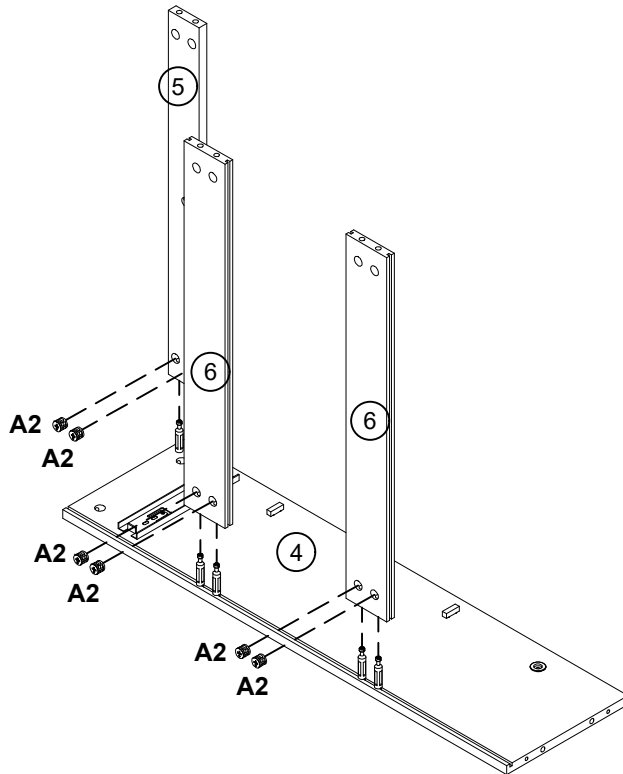

	A2x6pcs
--	---------

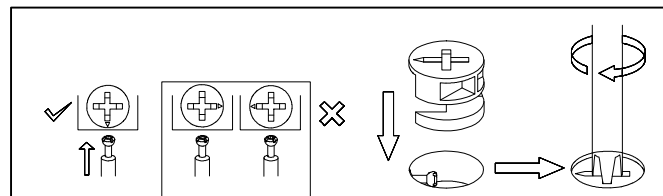

Schritt 5

Step 5

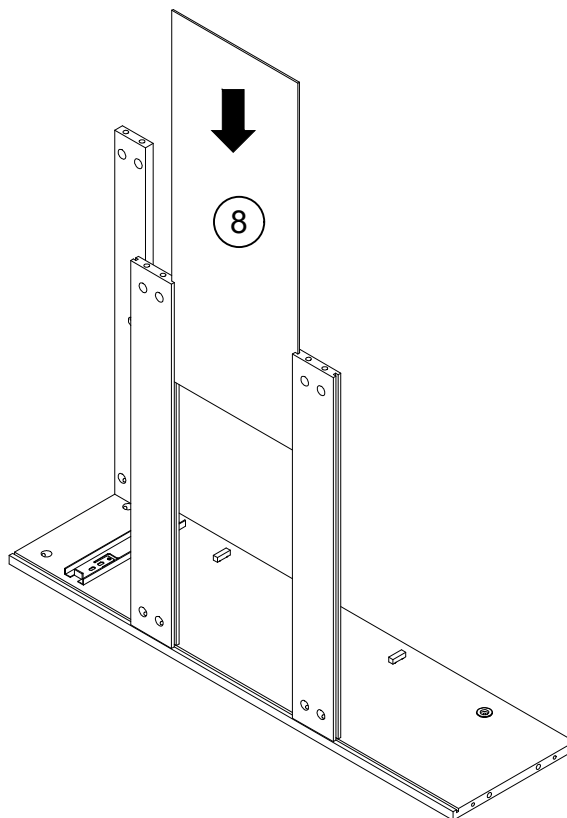

Schritt 6

Step 6

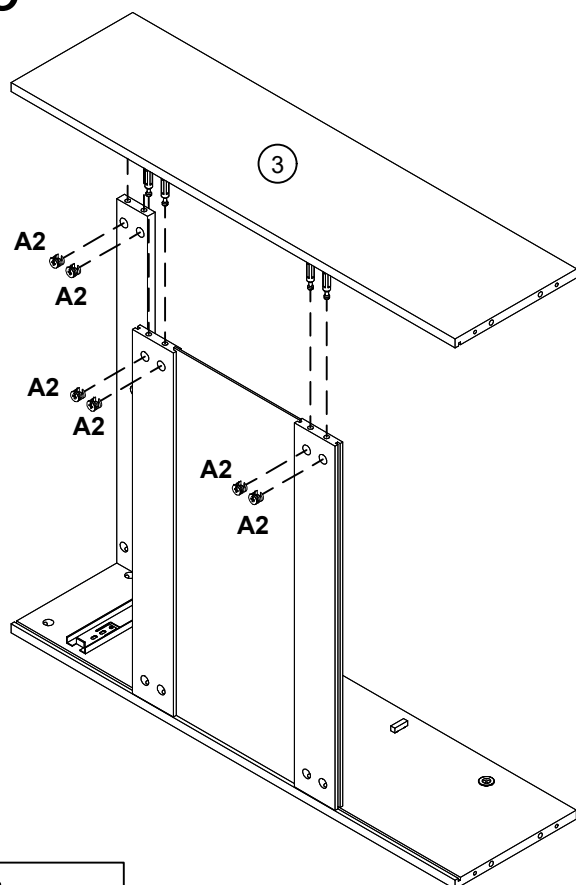

A2x6pcs

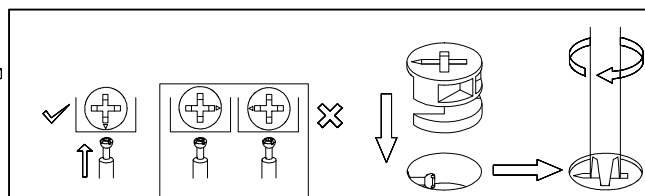

Schritt 7

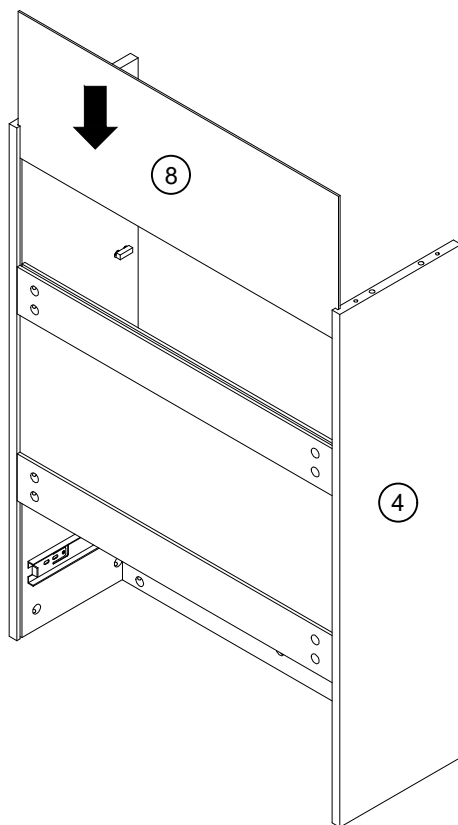

Step 7

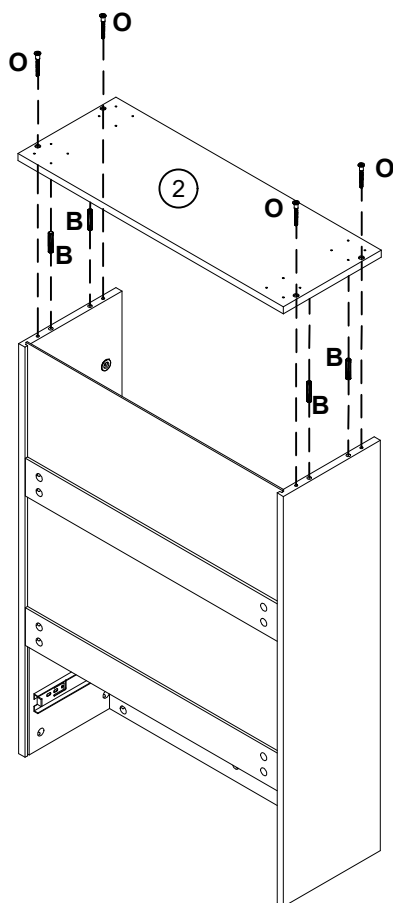

Schritt 8

Step 8



	Bx4pcs
	Ox4pcs

Schritt 9

Step 9

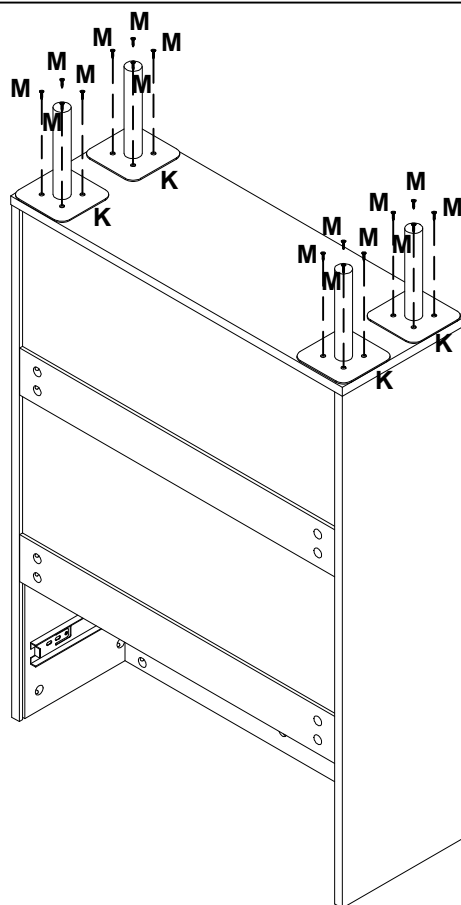

Kx4pcs



Mx16pcs

Schritt 10

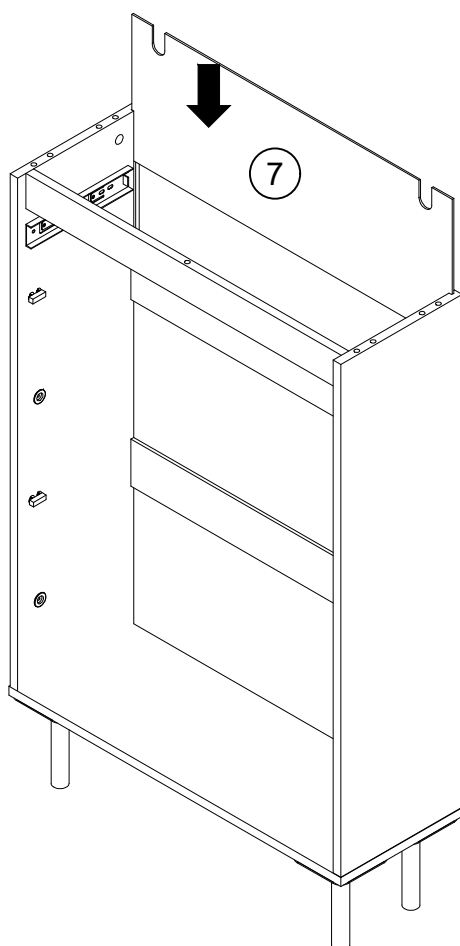

Step 10

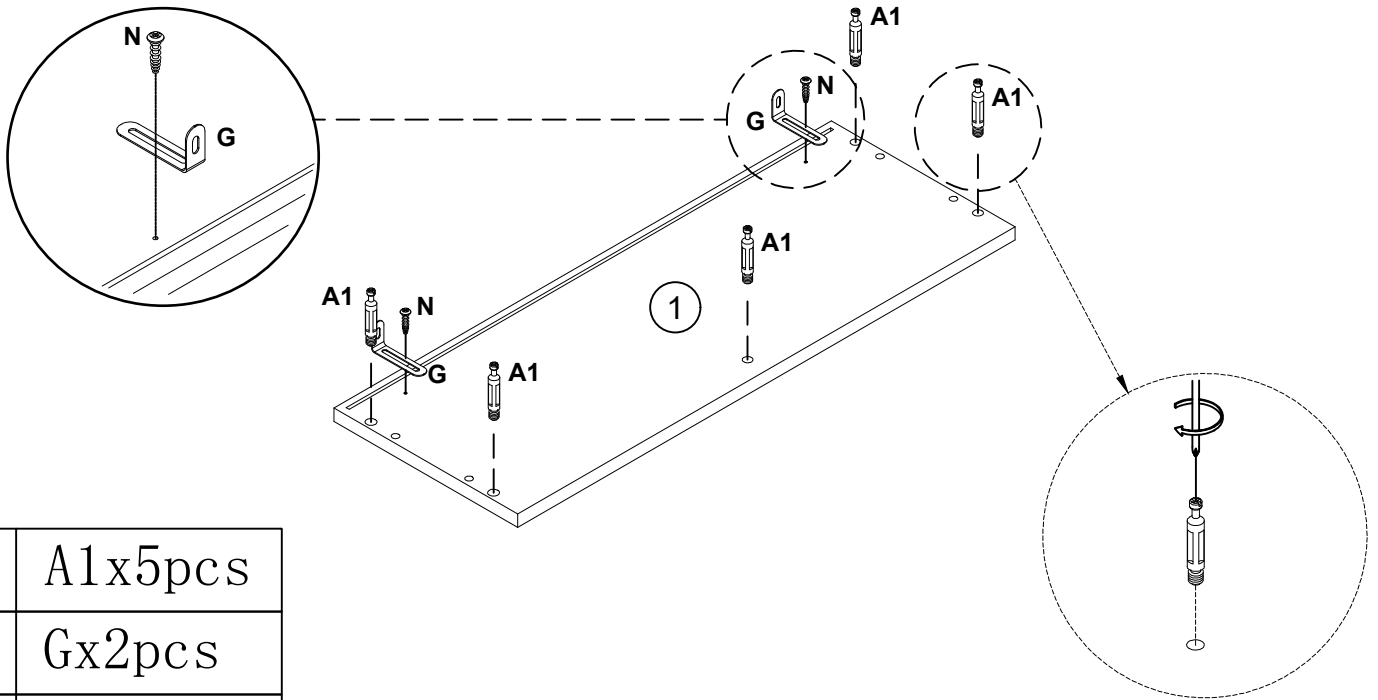

Schritt 11

Step 11





	A1x5pcs
	Gx2pcs
	Nx2pcs

Schritt 12

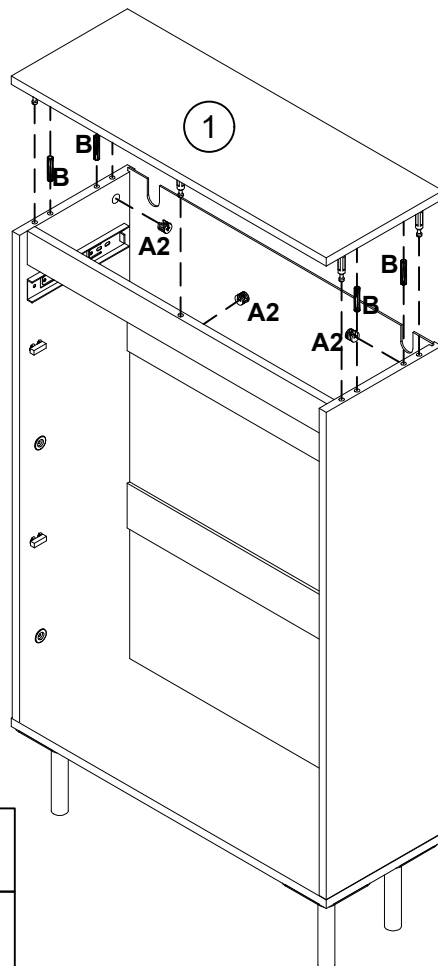
Step 12



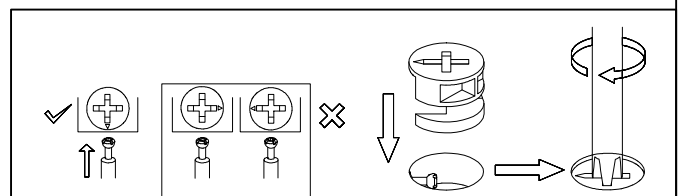

	A2x5pcs
	Bx4pcs

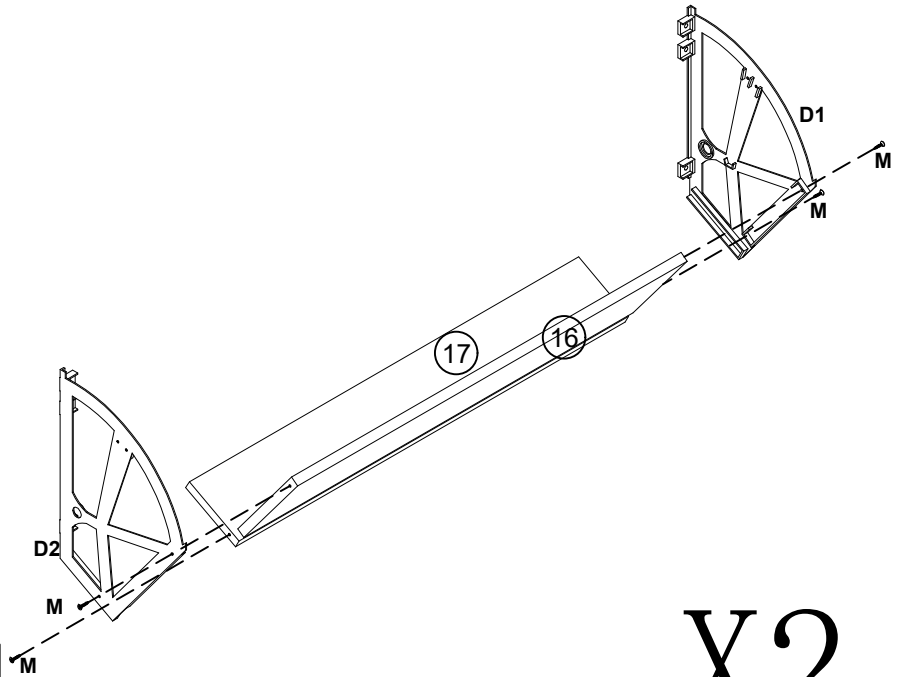

Schritt 13

Step 13







	Dx2pcs
	Mx8pcs

X2

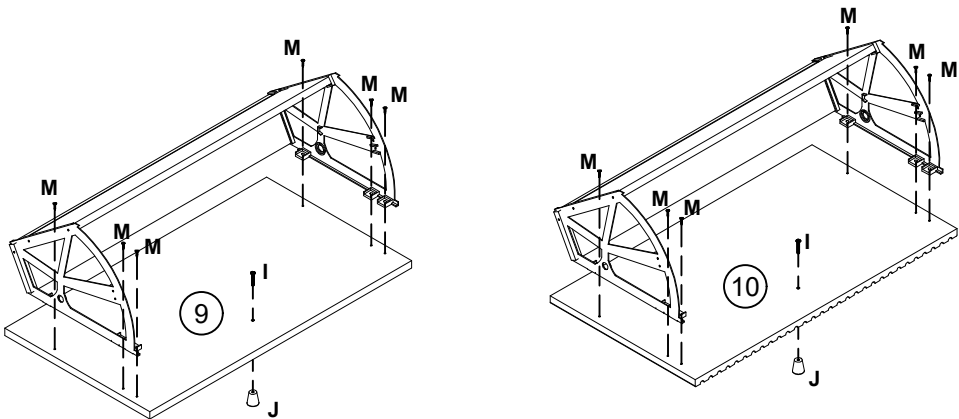
Schritt 14

Step 14



	Ix2pcs		Jx2pcs		Mx12pcs
---	--------	---	--------	---	---------

Schritt 15

Step 15

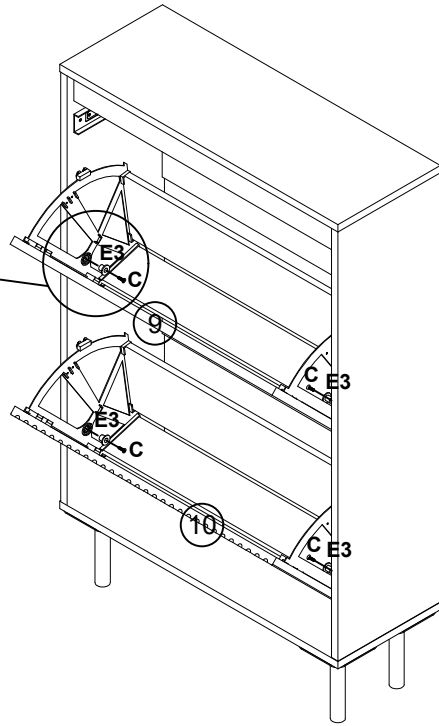
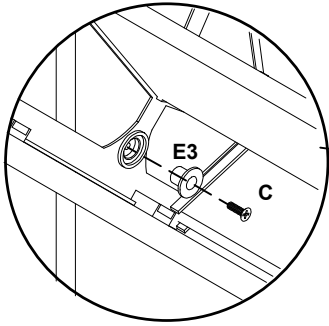

Cx4pcs



E3x4pcs

Schritt 16

Step 16

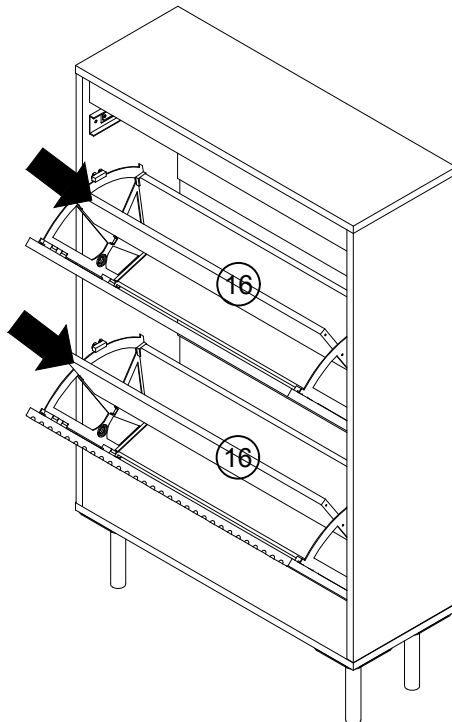

Schritt 17

Step 17

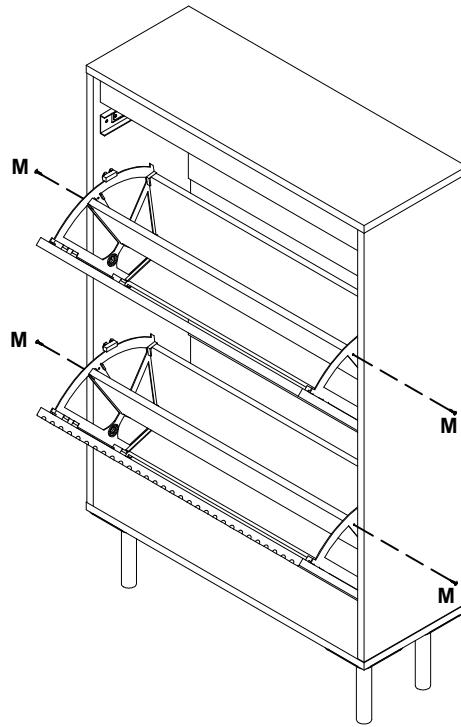

Mx4pcs

Schritt 18

Step 18

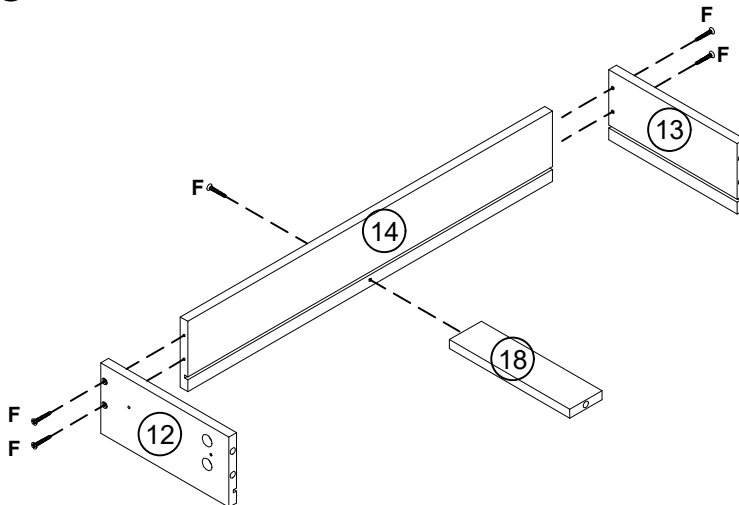

Fx5pcs

Schritt 19

Step 19

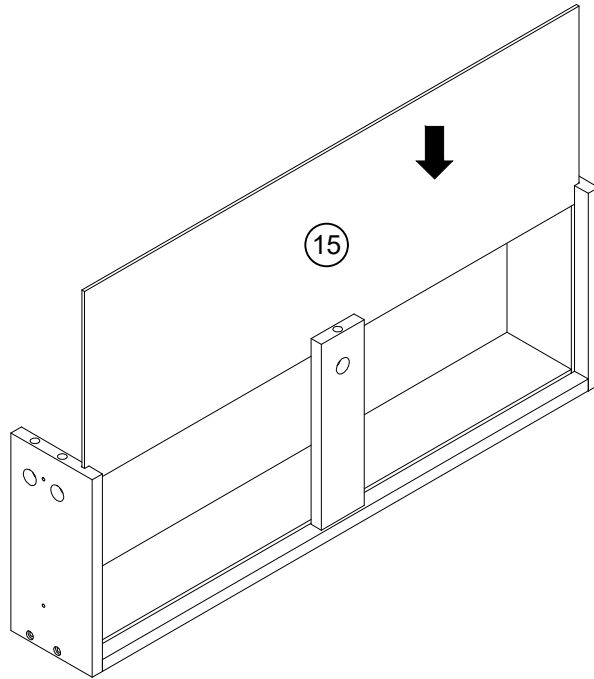

Schritt 20

Step 20

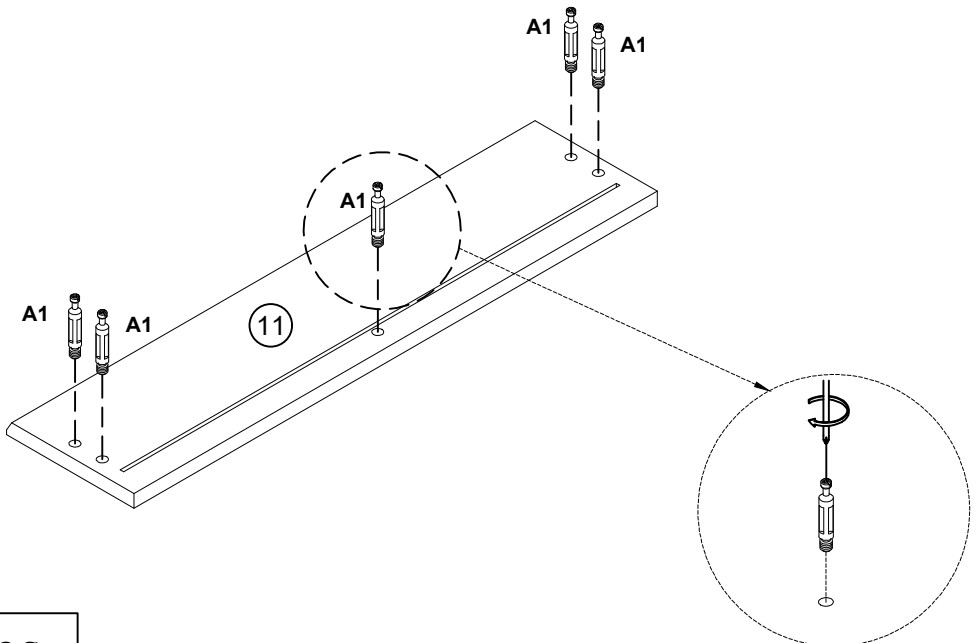

A1x5pcs

Schritt 21

Step 21

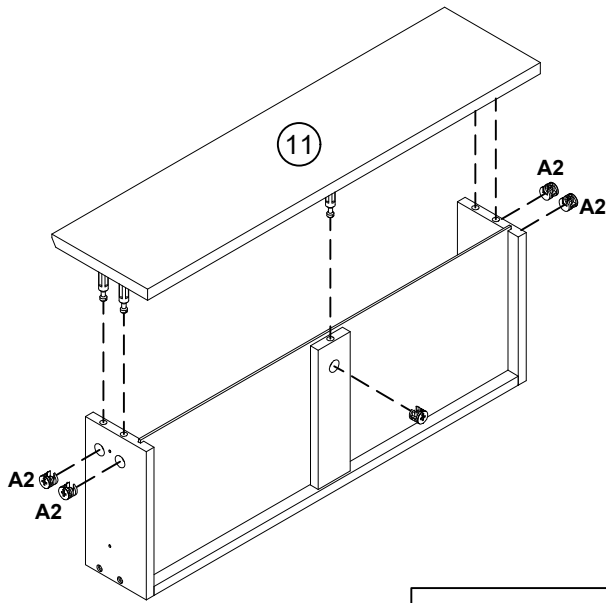

A2x5pcs

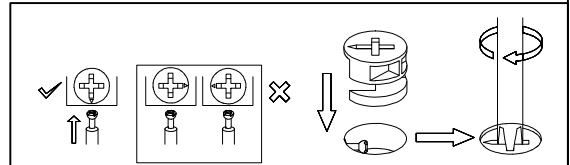

Schritt 22

Step 22

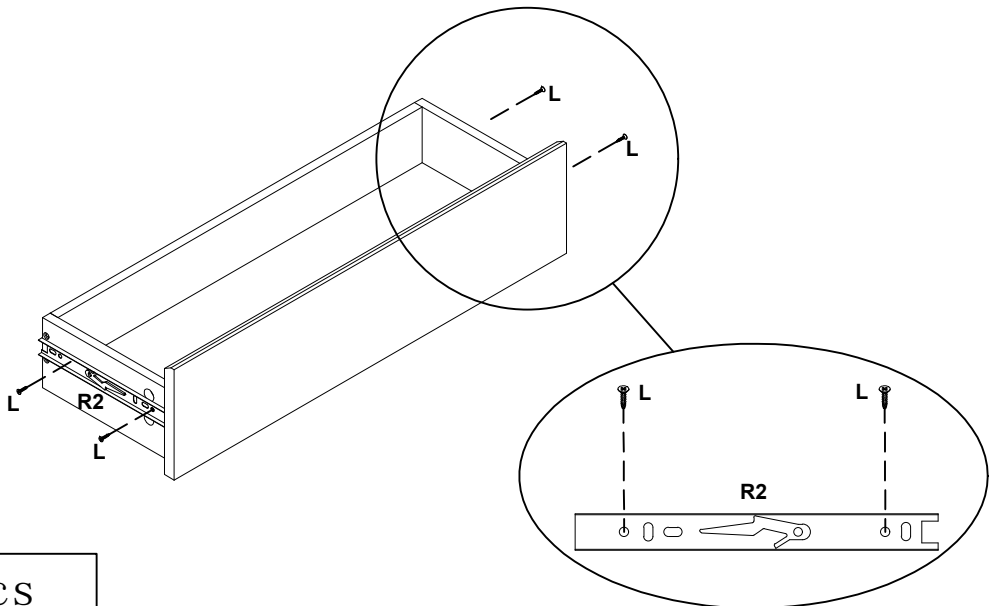

Lx4pcs

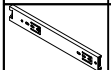



Rx1pc

Schritt 23

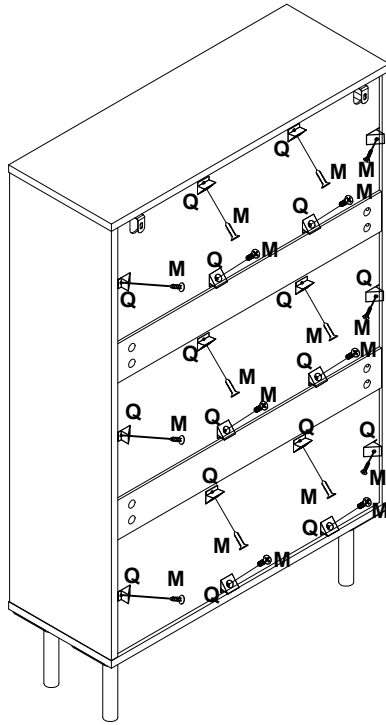
Step 23





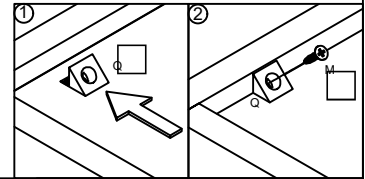

	Mx18pcs
	Qx18pcs

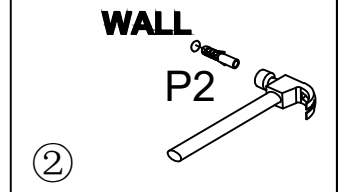
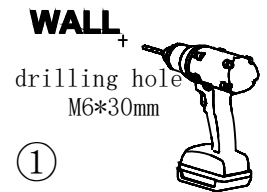
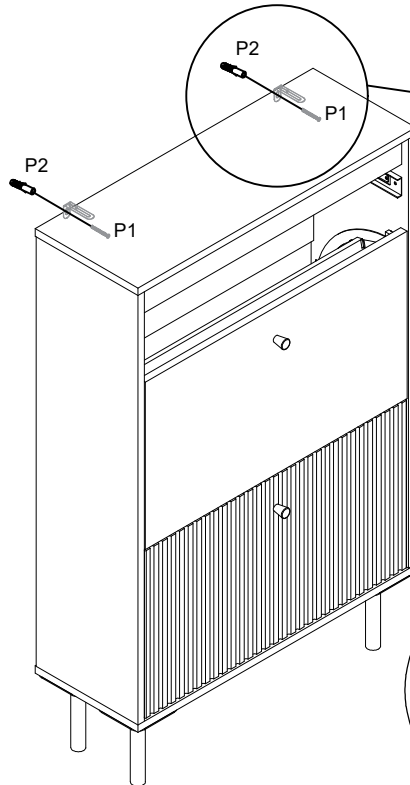

Schritt 24

Step 24



	Hx22pcs
	P1x2pcs
	P2x2pcs

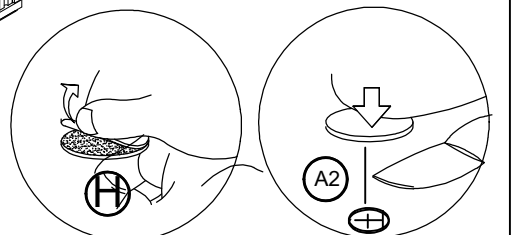

Schritt 25

Step 25

