

Installation sanleitung Installation Instruction Instruction d'installation



FR

Cet appareil,
ses cordons,
et batterie
se recyclent

À DÉPOSER
EN MAGASIN

À DÉPOSER
EN DÉCHÈTERIE



OU



Points de collecte sur www.quefairedesdechets.fr
Privilégiez la réparation ou le don de votre appareil !

SKU : N623P446761

SKU : N623P446762

SKU : N623P446763

SKU : N623P446764

Importeur	DECUBUS HANDEL GMBH
Adresse	Innungstraße 9, 21244 Buchholz, Deutschland
URL	https://www.decobusgroup.de
Hersteller	XINDEYA GROUP LIMITED
Add	Zhengyang Road, Chengyang District, Qingdao City
Email	sofa1_furniture@163.com
Hergestellt in	CHINA
EC REP	Decobus Handel GmbH Innungstraße 9, 21244 Buchholz, Deutschland https://www.decobusgroup.de

Holzbetten 140*200cm

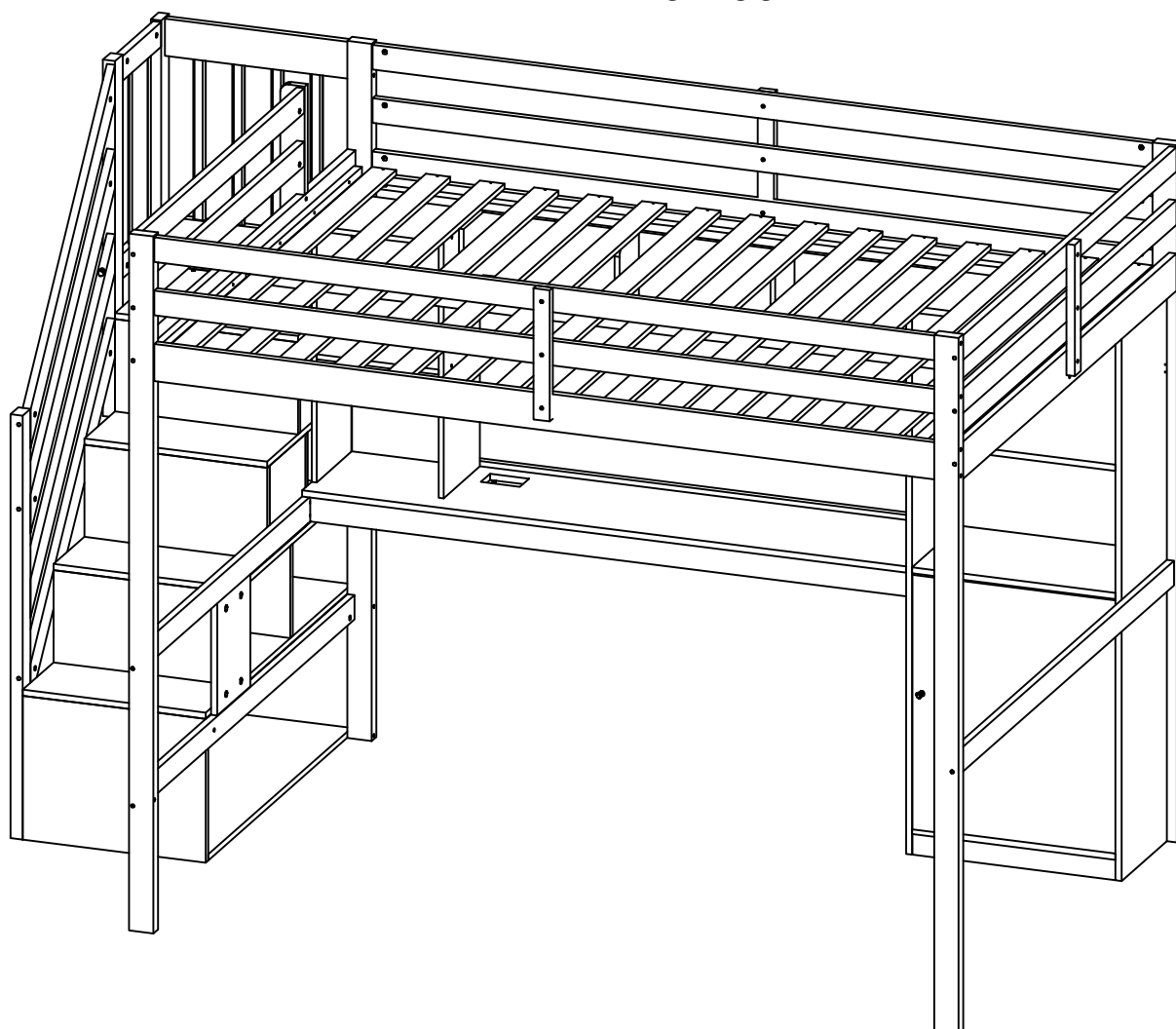

Unser Produkt wird Ihnen in 4 Paketen geliefert. Die Lieferzeiten dieser 4 Pakete können abweichen, bitte haben Sie etwas Geduld und vielen Dank für Ihr Verständnis.

Our product will be delivered to you in 4 packages. The delivery times of these 4 packages may differ, please be patient and thank you for your understanding.

Notre produit vous sera livré en 4 colis. Les délais de livraison de ces 4 colis peuvent différer, soyez patient et merci pour votre compréhension.

IMPORTANT- READ CAREFULLY-

RETAIN FOR FUTURE REFERENCE

TOP TIPS BEFORE YOU START !

1. Please check that all parts & hardware are present before you start the assembly of your furniture.
2. For ease and speed of assembly, we recommend that before you commence each step of the assembly,

Please identify all the parts required for that step.
3. We recommend that where possible, all items are assembled near to the area in which they will be placed in use,

to avoid moving the product unnecessarily once assembled.
4. For the protection of your furniture, particularly items of high gloss finish, we recommend that the product is placed on a

Protected surface during assembly to prevent any damage.
5. During assembly please take care not to over-tighten any fittings, as this may damage the product.

CARE AND MAINTENANCE OF YOUR FURNITURE

1. Please periodically check all fittings and re-tighten as necessary.
2. To clean your item, please use a damp cloth and wipe clean.
3. Never allow any kind of liquid to remain on your furniture. Absorption can cause wood to warp or finishes to de-laminate.
4. Please do not place hot items (e.g hot drinks) directly on the wood surface.
5. Please do not drag or pull your furniture.

IMPORTANT INFORMATION

1. The recommended size of mattress: (W)140cm x (L) 200cm x (H) 10cm.
2. Maximum thickness of mattress: 10cm.
3. Children should be discouraged from playing on top of this bunk bed.
4. The bunk bed should be checked periodically by the owner to ensure that the guardrail, ladder, and other components are maintained in the correct position and state of repair and that all connectors are tight.
5. A bunk bed is not to be placed near a ceiling fan unless the distance between the closest points on the ceiling fan bunk. Bed is at least 2 metres.
6. Use guardrails on both sides of upper bunk.

7. Children should play sensibly in and around the bed to avoid falling and injury.
8. The bed is designed for one person on each level only.
9. Use Ladder for entering and leaving upper bunk.
10. If the bunk bed will be placed next to the wall, the guardrail that runs the full length of the bed should be placed against The wall to prevent entrapment between the bed and the wall.
11. WARNING Do not use the bunk bed/high bed if any structural part is broken or missing.
12. Ventilation of the room is necessary in order to keep the humidity low and to prevent mould in and around the bed.
13. WARNING "high beds & the upper bed of bunk beds are not suitable for children under six years due to risk of injury from falls".
14. WARNING "children can become trapped between the bed & the wall, a roof pitch, the ceiling, adjoining pieces of furniture (e.g. cupboards) and the like. To avoid risk of serious injury the distance between the top safety barrier and the adjoining structure shall not exceed 75mm nor shall be more than 230mm".
15. WARNING: Always ensure the platform and the stairs are permanently attached to this bunk bed before use.
16. A statement to check regularly that all assembly fastenings are properly tightened;
17. Always follow the manufacturer's instructions.

STRANGULATION HAZARD:

18. Never attach or hang items to any part of the bunk bed that are not designed for use with the bed for example, but not limited to hooks, belts and jump ropes.
19. WARNING "Bunk Beds and high beds can present a serious risk of injury from strangulation if not used correctly. Never attach or hang items to any part of the bunk bed that are not designed to be used with the bed. for example, but not limited to ropes, strings, cords, hooks, belts and bags".

WICHTIG - SORGFÄLTIG LESEN - FÜR SPÄTERE VERWENDUNG AUFBEWAHREN

TOP-TIPPS, BEVOR SIE STARTEN!

1. Bitte überprüfen Sie, ob alle Teile und Beschläge vorhanden sind, bevor Sie mit der Montage Ihrer Möbel beginnen.
2. Für eine einfache und schnelle Montage empfehlen wir, dass Sie vor jedem Montageschritt Bitte identifizieren Sie alle für diesen Schritt erforderlichen Teile.
3. Wir empfehlen, alle Artikel möglichst in der Nähe des Einsatzortes zu montieren.
um ein unnötiges Bewegen des Produkts nach der Montage zu vermeiden.
4. Zum Schutz Ihrer Möbel, insbesondere von Möbeln mit Hochglanzoberfläche, empfehlen wir, das Produkt auf einen
Geschützte Oberfläche während der Montage um eventuelle Beschädigungen zu vermeiden.
5. Achten Sie bei der Montage darauf, die Verschraubungen nicht zu fest anzuziehen, da dies zu einer Beschädigung des Produkts führen kann.

PFLEGE UND WARTUNG IHRER MÖBEL

1. Bitte überprüfen Sie regelmäßig alle Verschraubungen und ziehen Sie sie bei Bedarf nach.
2. Verwenden Sie zum Reinigen Ihres Artikels bitte ein feuchtes Tuch und wischen Sie ihn sauber.
3. Lassen Sie niemals Flüssigkeiten auf Ihren Möbeln zurück. Durch die Aufnahme kann sich das Holz verziehen oder die Oberfläche kann sich ablösen.
4. Bitte stellen Sie keine heißen Gegenstände (z. B. heiße Getränke) direkt auf die Holzoberfläche.
5. Bitte schleifen oder ziehen Sie Ihre Möbel nicht.

WICHTIGE INFORMATIONEN

1. Die empfohlene Matratzengröße: (B)140 cm x (L) 200 cm x (H) 10 cm.
2. Maximale Matratzendicke: 10 cm.
3. Kinder sollten davon abgehalten werden, auf diesem Etagenbett zu spielen.
4. Das Etagenbett sollte regelmäßig vom Eigentümer überprüft werden, um sicherzustellen, dass Geländer, Leiter und andere Komponenten in der richtigen Position und im richtigen Zustand gehalten werden und dass alle Verbindungselemente fest sind.
5. Ein Etagenbett darf nicht in der Nähe eines Deckenventilators aufgestellt werden, es sei denn, der Abstand zwischen den nächstgelegenen Punkten des Etagenbetts mit Deckenventilator beträgt mindestens 2 Meter.

6. Verwenden Sie an beiden Seiten der oberen Koje Schutzgeländer.
7. Kinder sollten vernünftig im und um das Bett spielen, um Stürze und Verletzungen zu vermeiden.
8. Das Bett ist auf jeder Ebene nur für eine Person ausgelegt.
9. Benutzen Sie die Leiter zum Ein- und Aussteigen aus dem oberen Bett.
10. Wenn das Etagenbett neben der Wand aufgestellt wird, sollte das über die gesamte Länge des Bettes verlaufende Schutzgeländer gegen Die Wand verhindert ein Einklemmen zwischen Bett und Wand.
11. **WARNUNG** Verwenden Sie das Etagenbett/Hochbett nicht, wenn ein Bauteil gebrochen ist oder fehlt.
12. Eine Belüftung des Zimmers ist notwendig, um die Luftfeuchtigkeit niedrig zu halten und Schimmelbildung im und um das Bett vorzubeugen.
13. **WARNUNG** „Hochbetten & das Oberbett von Etagenbetten sind wegen Verletzungsgefahr durch Stürze nicht für Kinder unter sechs Jahren geeignet.“
14. **WARNUNG:** „Kinder können zwischen Bett und Wand, einer Dachschräge, der Decke, angrenzenden Möbelstücken (z. B. Schränken) und dergleichen eingeklemmt werden. Um die Gefahr schwerer Verletzungen zu vermeiden, darf der Abstand zwischen der oberen Sicherheitsbarriere und der angrenzenden Struktur 75 mm nicht überschreiten und nicht mehr als 230 mm betragen.“
15. **WARNUNG:** Stellen Sie immer sicher, dass die Plattform und die Treppe vor dem Gebrauch dauerhaft an diesem Etagenbett befestigt sind.
16. Eine Anweisung, regelmäßig zu überprüfen, ob alle Montagebefestigungen richtig angezogen sind;
17. Befolgen Sie immer die Anweisungen des Herstellers.

STRANGULATIONSGEFAHR:

18. Befestigen oder hängen Sie niemals Gegenstände an Teilen des Etagenbetts auf, die nicht für die Verwendung mit dem Bett vorgesehen sind (z. B. Haken, Gürtel und Springseile).
19. **WARNUNG** „Bei unsachgemäßer Verwendung von Etagenbetten und Hochbetten besteht die Gefahr einer Strangulation. Befestigen oder hängen Sie niemals Gegenstände an Teilen des Etagenbetts auf, die nicht für die Verwendung mit dem Bett vorgesehen sind. Dies sind beispielsweise , jedoch nicht ausschließlich, Seile, Schnüre, Kordeln, Haken, Gürtel und Taschen.“

IMPORTANT- À LIRE ATTENTIVEMENT- À CONSERVER POUR RÉFÉRENCE FUTURE

LES BONS CONSEILS AVANT DE COMMENCER !

1. Veuillez vérifier que toutes les pièces et le matériel sont présents avant de commencer l'assemblage de vos meubles.
2. Pour faciliter et accélérer l'assemblage, nous vous recommandons, avant de commencer chaque étape de l'assemblage,

Veuillez identifier toutes les pièces requises pour cette étape.

3. Nous recommandons que, dans la mesure du possible, tous les articles soient assemblés à proximité de la zone dans laquelle ils seront utilisés,

pour éviter de déplacer inutilement le produit une fois assemblé.

4. Pour la protection de vos meubles, en particulier des articles à finition brillante, nous vous recommandons de placer le produit sur un

Surface protégée lors du montage pour éviter tout dommage.

5. Lors de l'assemblage, veillez à ne pas trop serrer les raccords, car cela pourrait endommager le produit.

SOIN ET ENTRETIEN DE VOS MEUBLES

1. Veuillez vérifier périodiquement tous les raccords et resserrer si nécessaire.
2. Pour nettoyer votre article, veuillez utiliser un chiffon humide et essuyer.
3. Ne laissez jamais aucun type de liquide rester sur vos meubles. L'absorption peut provoquer la déformation du bois ou le délaminage des finitions.
4. Veuillez ne pas placer d'objets chauds (par exemple des boissons chaudes) directement sur la surface du bois.
5. Veuillez ne pas traîner ou tirer vos meubles.

UNE INFORMATION IMPORTANT

1. La taille recommandée du matelas : (L)140cm x (L) 200 cm x (H) 10 cm.
2. Épaisseur maximale du matelas : 10 cm.
3. Il convient de décourager les enfants de jouer sur ce lit superposé.
4. Le lit superposé doit être vérifié périodiquement par le propriétaire pour s'assurer que le garde-corps, l'échelle et les autres composants sont maintenus dans la bonne position et en bon état et que tous les connecteurs sont bien serrés.

5. Un lit superposé ne doit pas être placé à proximité d'un ventilateur de plafond, à moins que la distance entre les points les plus proches du ventilateur de plafond ne soit respectée. Le lit mesure au moins 2 mètres.
6. Utilisez des garde-corps des deux côtés du lit supérieur.
7. Les enfants doivent jouer raisonnablement dans et autour du lit pour éviter les chutes et les blessures.
8. Le lit est conçu pour une seule personne à chaque niveau.
9. Utilisez l'échelle pour entrer et sortir du lit supérieur.
10. Si le lit superposé doit être placé près du mur, le garde-corps qui s'étend sur toute la longueur du lit doit être placé contre le mur pour éviter tout coincement entre le lit et le mur.
11. AVERTISSEMENT N'utilisez pas le lit superposé/lit surélevé si une pièce structurelle est cassée ou manquante.
12. La ventilation de la pièce est nécessaire afin de maintenir un faible taux d'humidité et d'éviter la moisissure dans et autour du lit.
13. AVERTISSEMENT "les lits hauts et le lit supérieur des lits superposés ne conviennent pas aux enfants de moins de six ans en raison du risque de blessure en cas de chute".
14. AVERTISSEMENT "Les enfants peuvent se retrouver coincés entre le lit et le mur, une pente de toit, le plafond, des meubles attenants (par exemple des placards) et autres. Pour éviter tout risque de blessure grave, la distance entre la barrière de sécurité supérieure et la barrière de sécurité adjacente la structure ne doit pas dépasser 75 mm ni dépasser 230 mm".
15. AVERTISSEMENT: Vérifiez toujours que la plate-forme et l'escalier sont fixés de manière permanente à ce lit superposé avant de l'utiliser.
16. Une déclaration demandant de vérifier régulièrement que toutes les fixations de l'assemblage sont correctement serrées ;
17. Suivez toujours les instructions du fabricant.

RISQUE D'ÉTRANGULATION :

18. N'attachez ou ne suspendez jamais d'objets à une partie du lit superposé qui ne sont pas conçus pour être utilisés avec le lit, par exemple, mais sans s'y limiter, des crochets, des ceintures et des cordes à sauter.
19. AVERTISSEMENT "Les lits superposés et les lits hauts peuvent présenter un risque sérieux de blessure par strangulation s'ils ne sont pas utilisés correctement. N'attachez ou ne suspendez jamais d'objets à une partie du lit superposé qui ne sont pas conçus pour être utilisés avec le lit. par exemple, mais sans s'y limiter, les cordes, ficelles, cordons, crochets, ceintures et sacs".

IMPORTANTE- LEER CON ATENCIÓN-

CONSERVAR PARA FUTURA REFERENCIA

¡MEJORES CONSEJOS ANTES DE COMENZAR!

1. Verifique que todas las piezas y herrajes estén presentes antes de comenzar a ensamblar sus muebles.

2. Para facilitar y acelerar el montaje, recomendamos que antes de comenzar cada paso del montaje,

Identifique todas las piezas necesarias para ese paso.

3. Recomendamos que, siempre que sea posible, todos los artículos se monten cerca del área en la que se utilizarán.

para evitar mover el producto innecesariamente una vez montado.

4. Para la protección de sus muebles, especialmente los artículos con acabado de alto brillo, recomendamos colocar el producto sobre una

Superficie protegida durante el montaje para evitar cualquier daño.

5. Durante el montaje, tenga cuidado de no apretar demasiado ningún accesorio, ya que esto podría dañar el producto.

CUIDADO Y MANTENIMIENTO DE TUS MUEBLES

1. Revise periódicamente todos los accesorios y vuelva a apretarlos según sea necesario.

2. Para limpiar su artículo, utilice un paño húmedo y límpielo.

3. Nunca permita que quede ningún tipo de líquido en sus muebles. La absorción puede causar que la madera se deforme o que los acabados se deslaminen.

4. No coloque artículos calientes (por ejemplo, bebidas calientes) directamente sobre la superficie de madera.

5. No arrastre ni tire de sus muebles.

INFORMACIÓN IMPORTANTE

1. El tamaño recomendado del colchón: (W)140cm x (L) 200 cm x (H) 10 cm.

2. Grosor máximo del colchón: 10cm.

3. Se debe disuadir a los niños de jugar encima de esta litera.

4. El propietario debe revisar periódicamente la litera para garantizar que la barandilla, la escalera y otros componentes se mantengan en la posición y estado correctos y que todos los conectores estén apretados.

5. No se debe colocar una litera cerca de un ventilador de techo a menos que la distancia entre los puntos más cercanos de la litera del ventilador de techo. La cama mide al menos 2 metros.
6. Utilice barandillas a ambos lados de la litera superior.
7. Los niños deben jugar con sensatez dentro y alrededor de la cama para evitar caídas y lesiones.
8. La cama está diseñada para una persona en cada nivel únicamente.
9. Utilice la escalera para entrar y salir de la litera superior.
10. Si la litera se va a colocar junto a la pared, la barandilla que recorre toda la longitud de la cama debe colocarse contra la pared para evitar atrapamientos entre la cama y la pared.
11. ADVERTENCIA No utilice la litera/cama alta si alguna pieza estructural está rota o falta.
12. La ventilación de la habitación es necesaria para mantener baja la humedad y evitar moho dentro y alrededor de la cama.
13. ADVERTENCIA "Las camas altas y la cama superior de las literas no son adecuadas para niños menores de seis años debido al riesgo de lesiones por caídas".
14. ADVERTENCIA "Los niños pueden quedar atrapados entre la cama y la pared, la pendiente del tejado, el techo, los muebles contiguos (por ejemplo, armarios) y similares. Para evitar el riesgo de lesiones graves, la distancia entre la barrera de seguridad superior y la barrera de seguridad contigua La estructura no excederá los 75 mm ni excederá los 230 mm".
15. ADVERTENCIA: Asegúrese siempre de que la plataforma y la escalera están fijadas permanentemente a esta litera antes de su uso.
16. Una declaración para comprobar regularmente que todas las fijaciones de montaje están bien apretadas;
17. Siga siempre las instrucciones del fabricante.

PELIGRO DE ESTRANGULACIÓN:

18. Nunca coloque ni cuelgue elementos en ninguna parte de la litera que no estén diseñados para usarse con la cama, por ejemplo, entre otros, ganchos, cinturones y cuerdas para saltar.
19. ADVERTENCIA "Las literas y las camas altas pueden presentar un riesgo grave de lesiones por estrangulamiento si no se usan correctamente. Nunca fije ni cuelgue elementos en ninguna parte de la litera que no estén diseñados para usarse con la cama, por ejemplo, pero no limitado a cuerdas, cordeles, cordones, ganchos, cinturones y bolsas".

IMPORTANTE - LEGGERE ATTENTAMENTE -

CONSERVARE PER RIFERIMENTO FUTURO

I MIGLIORI CONSIGLI PRIMA DI INIZIARE!

1. Verificare che tutte le parti e l'hardware siano presenti prima di iniziare l'assemblaggio dei mobili.
2. Per facilitare e velocizzare l'assemblaggio, si consiglia prima di iniziare ogni fase dell'assemblaggio, identificare tutte le parti necessarie per questo passaggio.
3. Raccomandiamo, ove possibile, che tutti gli articoli siano assemblati vicino all'area in cui verranno utilizzati, per evitare di spostare inutilmente il prodotto una volta assemblato.
4. Per la protezione dei tuoi mobili, in particolare degli articoli con finitura lucida, ti consigliamo di posizionare il prodotto su a Superficie protetta durante il montaggio per evitare eventuali danni.
5. Durante il montaggio fare attenzione a non stringere eccessivamente i raccordi, poiché ciò potrebbe danneggiare il prodotto.

CURA E MANUTENZIONE DEI VOSTRI MOBILI

1. Controllare periodicamente tutti i raccordi e serrarli nuovamente se necessario.
2. Per pulire l'articolo, utilizzare un panno umido e pulirlo.
3. Non lasciare mai alcun tipo di liquido sui mobili. L'assorbimento può causare la deformazione del legno o la delaminazione delle finiture.
4. Si prega di non posizionare oggetti caldi (ad esempio bevande calde) direttamente sulla superficie del legno.
5. Si prega di non trascinare o tirare i mobili.

INFORMAZIONI IMPORTANTI

1. Dimensioni consigliate del materasso: (L)140cm x (L) 200 cm x (A) 10 cm.
2. Spessore massimo del materasso: 10 cm.
3. I bambini dovrebbero essere scoraggiati dal giocare sul letto a castello.
4. Il letto a castello deve essere controllato periodicamente dal proprietario per garantire che il parapetto, la scala e gli altri componenti siano mantenuti nella posizione corretta e in stato di riparazione e che tutti i connettori siano serrati.
5. Un letto a castello non deve essere posizionato vicino a un ventilatore da soffitto, a meno che non sia rispettata la distanza tra i punti più vicini sul letto a castello. Il letto è di almeno 2 metri.

6. Utilizzare le sponde su entrambi i lati del letto superiore
7. I bambini dovrebbero giocare in modo sensato dentro e intorno al letto per evitare cadute e lesioni.
8. Il letto è previsto per una sola persona su ogni livello.
9. Usa la scala per entrare e uscire dalla cuccetta superiore.
10. Se il letto a castello verrà posizionato vicino al muro, la ringhiera che corre per tutta la lunghezza del letto deve essere posizionata contro il muro per evitare intrappolamenti tra il letto e il muro.
11. **ATTENZIONE** Non utilizzare il letto a castello/letto sopraelevato se qualche parte strutturale è rotta o mancante.
12. La ventilazione della stanza è necessaria per mantenere bassa l'umidità e prevenire la formazione di muffe all'interno e attorno al letto.
13. **ATTENZIONE** "I letti alti e il letto superiore dei letti a castello non sono adatti a bambini di età inferiore a sei anni a causa del rischio di lesioni dovute a cadute".
14. **AVVERTENZA** "I bambini possono rimanere intrappolati tra il letto e il muro, la falda del tetto, il soffitto, i mobili adiacenti (ad esempio armadi) e simili. Per evitare il rischio di lesioni gravi, la distanza tra la barriera di sicurezza superiore e quella adiacente la struttura non deve superare i 75 mm né essere superiore ai 230 mm".
15. **AVVERTENZA:** Assicurarsi sempre che la piattaforma e la scala siano fissate in modo permanente a questo letto a castello prima dell'uso.
16. Una dichiarazione di controllare regolarmente che tutti i fissaggi di montaggio siano correttamente serrati;
17. Seguire sempre le istruzioni del produttore.

PERICOLO DI STRANGOLAMENTO:

18. Non attaccare o appendere mai oggetti a qualsiasi parte del letto a castello che non siano progettati per l'uso con il letto, ad esempio, ma non limitati a ganci, cinture e corde per saltare.
19. **AVVERTENZA** "I letti a castello e i letti alti possono presentare un grave rischio di lesioni da strangolamento se non utilizzati correttamente. Non attaccare o appendere mai oggetti a qualsiasi parte del letto a castello che non siano progettati per essere utilizzati con il letto, ad esempio, ma non limitato a corde, spaghi, corde, ganci, cinture e borse".

English

IMPORTANT ! KEEP FOR FUTURE REFERENCE : READ CAREFULLY

- To be assembled by an adult. Assembly must be checked by an adult before use
- WARNING ! Keep all screws, small parts and plastic bags out of the reach of children
- Properly identify all parts before assembling
- Never use your item if any of its parts are broken or missing
- Should any problems arise, please contact our After Sales Service
- Manufacturer's instructions shall be followed at all times
- Care: Clean with a soft, dry cloth. In case of larger stains, carefully rub with a slightly damp, non-abrasive sponge
- Avoid the risk of fire by not placing furniture near sources of ignition or hot items
- Do not jump on the bed

Deutsch

WICHTIG ! ZUM SPÄTEREN NACHSCHLAGEN AUFBEWAHREN: SORGFÄLTIG LESEN

- Muss von einem Erwachsenen zusammengebaut werden. Der Zusammenbau muss vor dem Gebrauch von einem Erwachsenen überprüft werden
- WARNUNG! Bewahren Sie alle Schrauben, Kleinteile und Plastikbeutel außerhalb der Reichweite von Kindern auf
- Kennzeichnen Sie vor dem Zusammenbau alle Teile richtig
- Benutzen Sie Ihren Artikel niemals, wenn Teile gebrochen sind oder fehlen
- Sollten Probleme auftreten, wenden Sie sich bitte an unseren Kundendienst
- Die Anweisungen des Herstellers sind stets zu befolgen
- Pflege: Mit einem weichen, trockenen Tuch reinigen. Bei größeren Flecken vorsichtig mit einem leicht feuchten, nicht scheuernden Schwamm abreiben. nicht scheuernden Schwamm
- Vermeiden Sie die Gefahr eines Brandes, indem Sie die Möbel nicht in der Nähe von Zündquellen oder heißen Gegenständen aufstellen
- Nicht auf das Bett springen

Français

IMPORTANT ! CONSERVER POUR RÉFÉRENCE ULTÉRIEURE : LIRE ATTENTIVEMENT

- Le montage doit être effectué par un adulte. Le montage doit être vérifié par un adulte avant Utilisation
- ATTENTION ! Tenir les vis, les petites pièces et les sachets en plastique hors de portée des enfants
- Identifiez correctement toutes les pièces avant de les assembler
- N'utilisez jamais votre article si l'une de ses pièces est cassée ou manquante
- En cas de problème, veuillez contacter notre service après-vente
- Les instructions du fabricant doivent être respectées à tout moment
- Entretien : nettoyer avec un chiffon doux et sec. En cas de taches plus importantes, frotter soigneusement avec une éponge non abrasive légèrement humide. légèrement humide et non Abrasive
- Évitez les risques d'incendie en ne plaçant pas les meubles à proximité de sources d'inflammation ou d'objets chauds
- Ne pas sauter sur le lit

Italiano

IMPORTANTE! CONSERVARE PER RIFERIMENTO FUTURO: LEGGERE ATTENTAMENTE

- Deve essere assemblato da un adulto. L'assemblaggio deve essere controllato da un adulto prima dell'uso
- **ATTENZIONE!** Tenere tutte le viti, le piccole parti e i sacchetti di plastica fuori dalla portata dei bambini
- Identificare correttamente tutte le parti prima dell'assemblaggio
- Non utilizzare mai l'articolo se alcune parti sono rotte o mancanti
- In caso di problemi, si prega di contattare il nostro Servizio Post Vendita
- Le istruzioni del produttore devono essere sempre seguite
- Cura: Pulire con un panno morbido e asciutto. In caso di macchie più estese, strofinare accuratamente con una spugna leggermente umida e nonspugna leggermente umida e non abrasiva
- Evitare il rischio di incendio, non collocando i mobili vicino a fonti di accensione o a oggetti caldi
- Non saltare sul letto

Español

¡ IMPORTANTE ! CONSERVELO PARA FUTURAS CONSULTAS: LEA ATENTAMENTE

- Debe ser montado por un adulto. El montaje debe ser comprobado por un adulto antes del uso
- ADVERTENCIA** Mantenga todos los tornillos, piezas pequeñas y bolsas de plástico fuera del alcance de los niños.
- Identifique correctamente todas las piezas antes de montarlas
 - Nunca utilice su artículo si alguna de sus piezas está rota o falta
 - Si surge algún problema, póngase en contacto con nuestro Servicio Postventa
 - Las instrucciones del fabricante deben seguirse en todo momento
 - Cuidado: Limpiar con un paño suave y seco. En caso de manchas más grandes, frote cuidadosamente con una esponja no abrasiva ligeramente humedecida.
 - Evite el riesgo de incendio no colocando los muebles cerca de fuentes de ignición u objetos calientes.
 - No saltar sobre la cama.

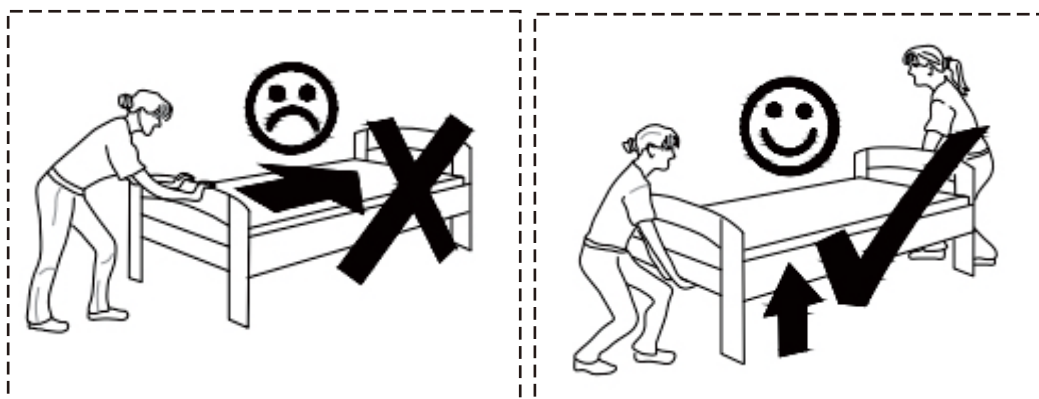

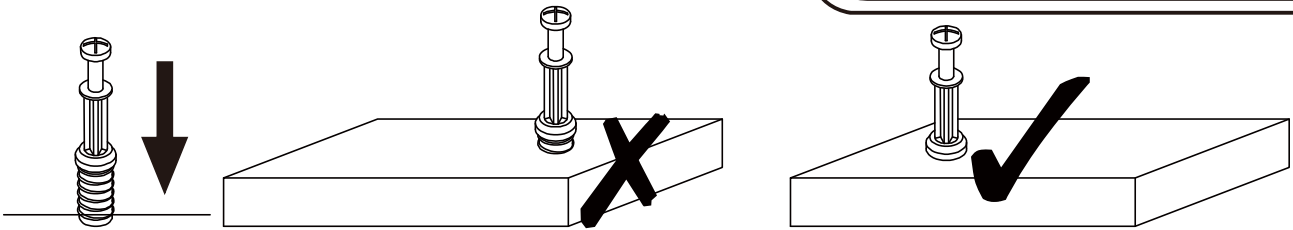

EN_QUICKFIT: Tighten quickfit until shoulder is flush with panel. Do not overtighten or undertighten.

FR_RACCORD RAPIDE: Faites serrer le raccord rapide jusqu'à ce que l'épaulement soit parfaitement encastré dans le panneau. Il ne faut ni trop serrer ni insuffisamment serrer.

ES_QUICKFIT: Apriete quickfit hasta que el hombro se descargue con el panel. NO lo sobreapriete ni lo apriete poco.

DE_QUICKFIT: Ziehen Sie den Quickfit fest, bis die Schulter mit der Platte bündig ist. Bitte nicht zu fest oder zu schwach anziehen.

IT_MONTAGGIO RAPIDO: Stringere il montaggio rapido fino a quando la spalla è a filo con il pannello, non stringere troppo o troppo poco.

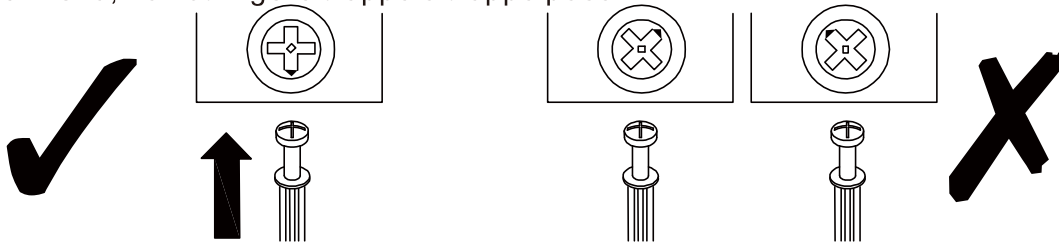

EN_CAM LOCK: When fitting cam lock, ensure starting position is correct before you insert connecting quickfit.

FR_SERRURE BATTEUSE: Avant d'insérer la serrure batteuse, veillez à la bonne orientation avant d'insérer le raccord rapide.

ES_CIERRE DE LA CÁMARA: Cuando instale el cierre de la cámara, asegúrese de que la posición de inicio es correcta antes de que inserte el quickfit conector.

DE_CAM-LOCK: Achten Sie bei der Montage des Cam-Locks auf die richtige Ausgangsposition, bevor Sie den Quickfit einsetzen.

IT_BLOCCAGGIO A CAMMA: Quando si monta il bloccaggio a camma, assicurarsi che la posizione iniziale sia corretta prima di inserire il montaggio rapido di collegamento.

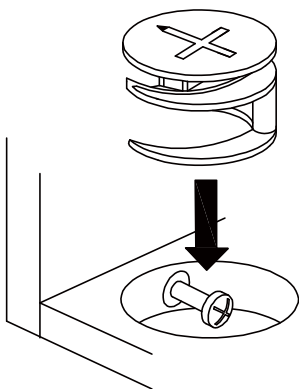

EN_Quickfit head should be in the centre of the cam lock when the two panels are joined.

Cam lock should be inserted before quickfit.

FR_Lorsque les deux panneaux sont assemblés, la tête du raccord rapide doit reposer au centre de la serrure batteuse. Il faut insérer la serrure batteuse avant le raccord rapide.

ES_El cabezal del quickfit debe estar en el centro del cierre de la cámara cuando se unan los dos paneles.

Se debe insertar el cierre de la cámara antes que el quickfit.

DE_Der Quickfit-Kopf sollte sich in der Mitte des Cam-Locks befinden, wenn die beiden Platten zusammengefügt sind.

Der Cam-Lock sollte vor dem Quickfit eingesetzt werden.

IT_La testa del montaggio rapido deve trovarsi al centro del bloccaggio a camma quando i due pannelli sono uniti.

Il Bloccaggio a Camma deve essere inserito prima del montaggio rapido.

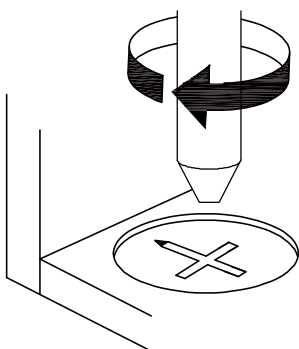

EN_Turn cam lock clockwise to tighten.

FR_Faites tourner la serrure batteuse dans le sens des aiguilles d'une montre pour la resserrer.

ES_Gire el cierre de la cámara en sentido horario para apretarlo.

DE_Drehen Sie den Cam-Lock im Uhrzeigersinn, um ihn festzuziehen.

IT_Ruotare il bloccaggio a camma in senso orario per stringere.

DE: Vor dem Einbau die Schrauben in die Löcher stecken und festziehen, aber nicht bis 100%, 70% bis 80% anziehen reicht aus. Schließlich, nachdem alle Schrauben installiert sind, ziehen Sie alle Schrauben auf 100%. Wenn Sie auf diese Probleme stoßen, wie z. B. Fehlausrichtung der Löcher oder Unfähigkeit, bestimmte Teile zu installieren, überprüfen Sie bitte, ob die Schrauben korrekt verwendet werden und passen Sie die Dichtigkeit der Schrauben an.

UK: Before installation, insert the screws into the holes and tighten them, but do not tighten them to 100%, 70% to 80% is sufficient. Finally, after all screws are installed, tighten all screws to 100%. If you encounter these issues, such as if the holes cannot be aligned or some parts cannot be installed, please check if the screws are used correctly and adjust the tightness of the screws.





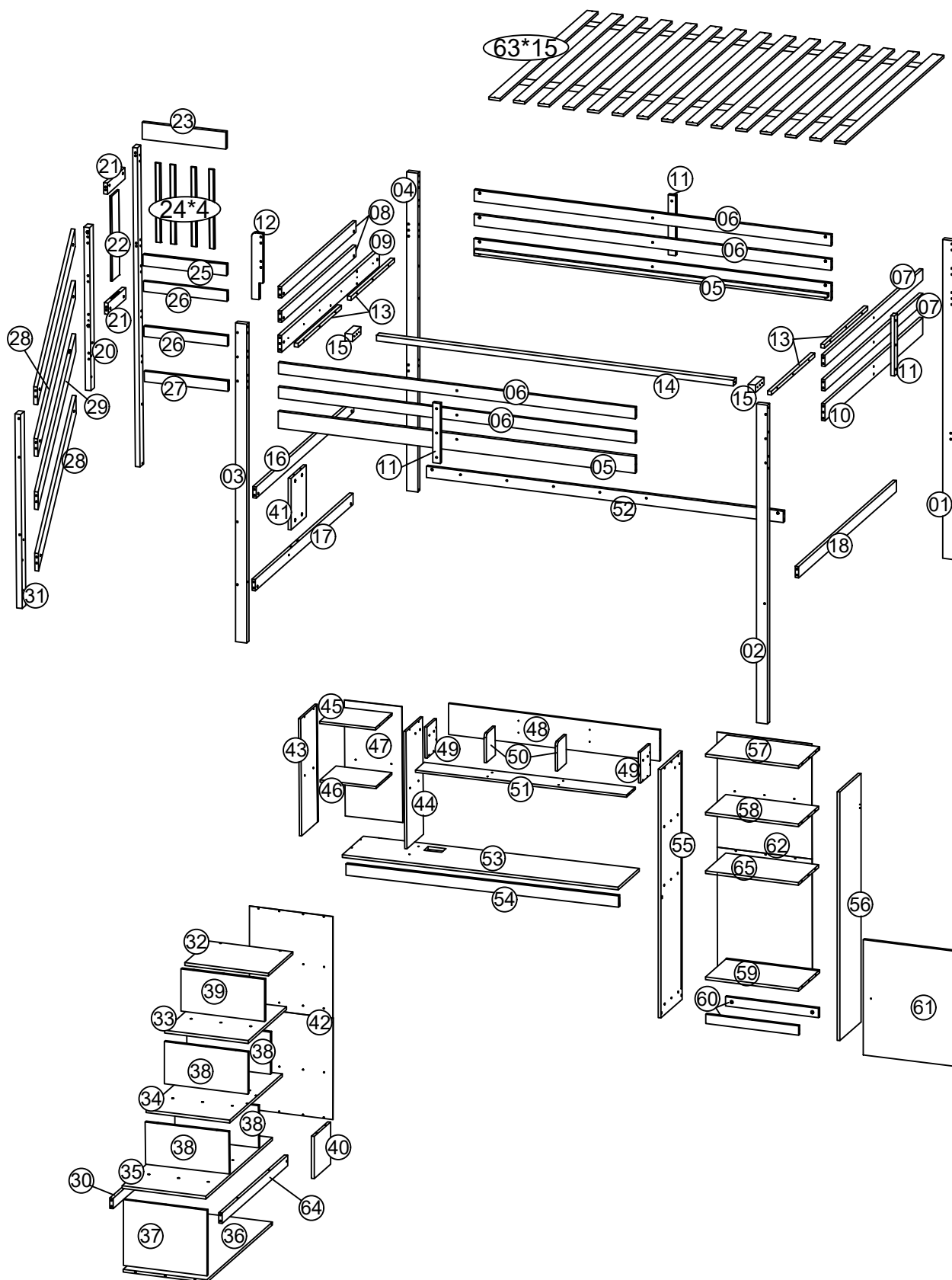







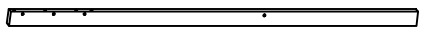

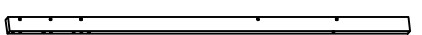
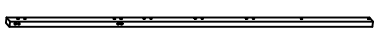
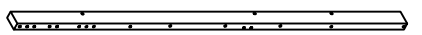
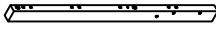
FR: Insérer la vis dans le trou avant la fin de l'assemblage, serrer la vis, mais ne pas serrer à 100%, 70% ~ 80% est correct. Enfin, une fois que toutes les vis sont bien serrées, toutes les vis sont serrées à 100%. Si vous rencontrez ces problèmes, par exemple si les trous ne sont pas alignés ou si certaines pièces ne peuvent pas être montées, vérifiez que les vis sont utilisées correctement et Ajustez leur serrage.

ASSEMBLY INSTRUCTIONS

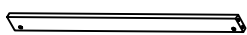

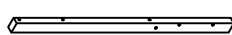

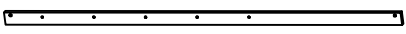

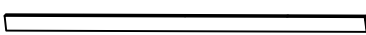





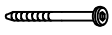





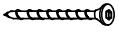

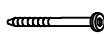
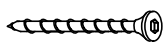



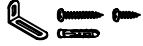



ASSEMBLY INSTRUCTIONS

N623P446761

1		1PC	14		1PC
2		1PC	15		2PCS
3		1PC	19		1PC
4		1PC	20		1PC
5		2PCS	21		2PCS
6		4PCS	22		1PC
8		2PCS	24		4PCS
11		3PCS	31		1PC
12		1PC	52		1PC
13		4PCS	54		1PC



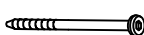
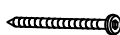







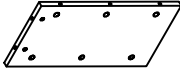
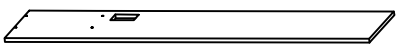

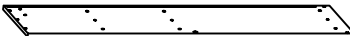
ASSEMBLY INSTRUCTIONS

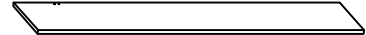
N623P446761

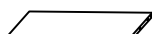
A	6x70		28PCS	R	6x15		4PC
B			66PCS	S			2PCS
C	Ø8x30		83PCS	T			4PCS
D	6x20		17PCS	U	Ø6x70		1PC
E	4x30		42PCS	V			2PCS
F	6x60		2PCS	W	Ø6x100		1PC
G	6x50		4PCS	X			1PC
H	6x100		25PCS	Y			2PCS
I			69PCS	Z			1PC
J			69PCS	AA	M4		2PCS
K	6x30		10PCS	BB	M3		1PC
L	3x14		62PCS	DD			1PC
M			1PC	FF	4x35		4PCS
N	Ø5x40		28PCS				
O	6x90		10PCS				
P	6x80		2PCS				
Q	Ø7x50		7PCS				

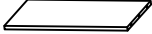



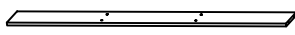



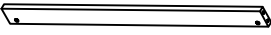

ASSEMBLY INSTRUCTIONS

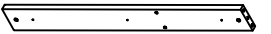
N623P446762

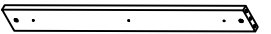
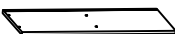
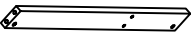
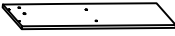
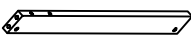
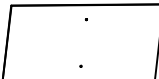
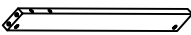



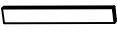
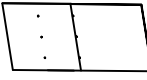
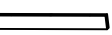

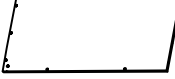
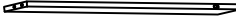

39		1PC	53		1PC
41		1PC	55		1PC
45		1PC	56		1PC
46		1PC	57		1PC
48		1PC	58		1PC
49		2PCS	59		1PC
50		2PCS	65		1PC
51		1PC			

ASSEMBLY INSTRUCTIONS

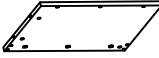
N623P4467563

7		2PCS	27		2PCS
9		1PC	42		1PC
10		1PC	43		1PC
16		1PC	44		1PC
17		1PC	47		1PC
18		1PC	60		2PCS
23		1PC	61		1PC
25		1PC	62		1PC
26		1PC	63		1PC



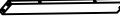

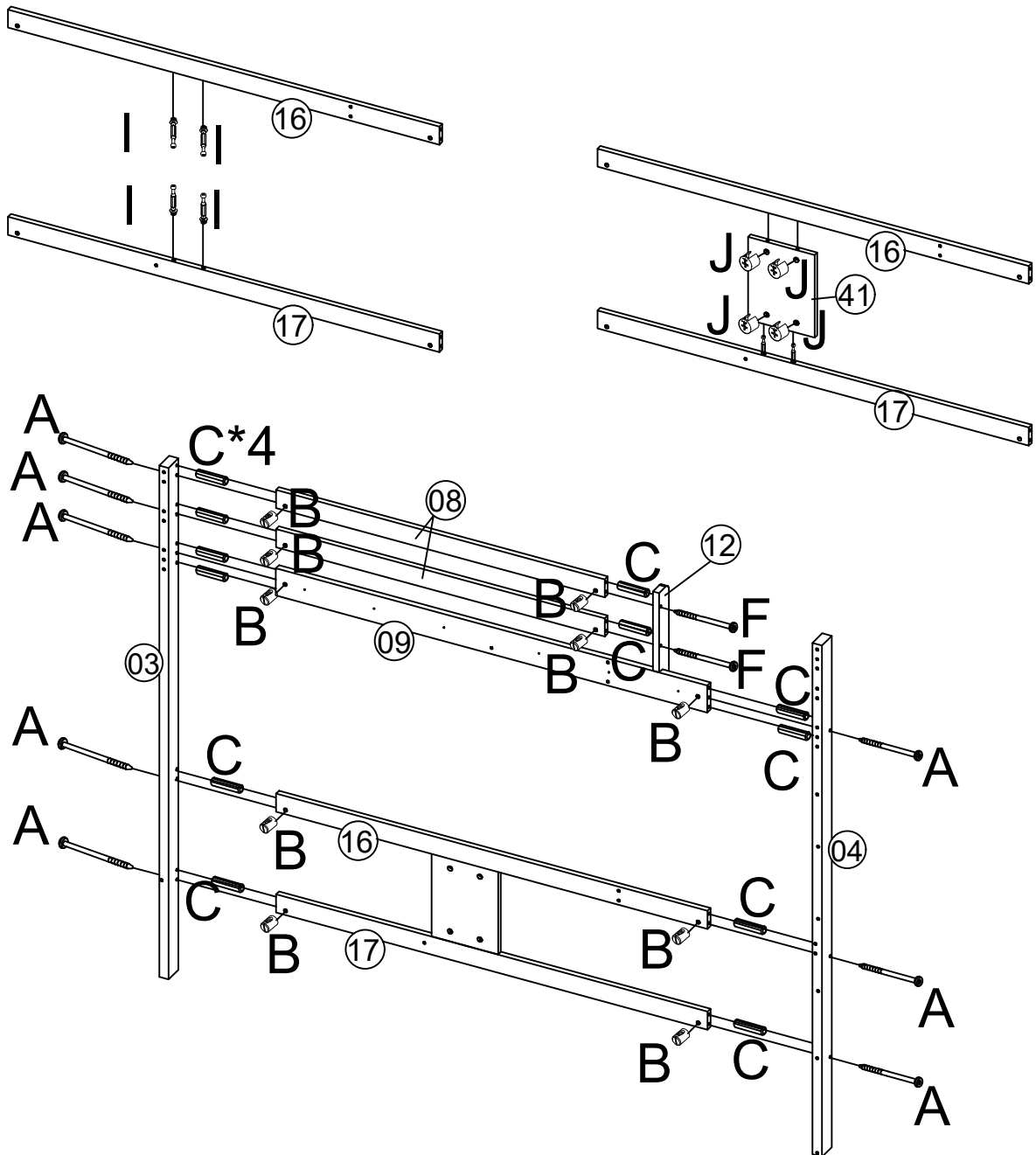

N623P4467564

28		3PCS	35		1PC
29		1PC	36		1PC
30		1PC	37		1PC
32		1PC	38		4PCS
33		1PC	40		1PC
34		1PC	64		1PC

ASSEMBLY INSTRUCTIONS

1

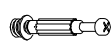



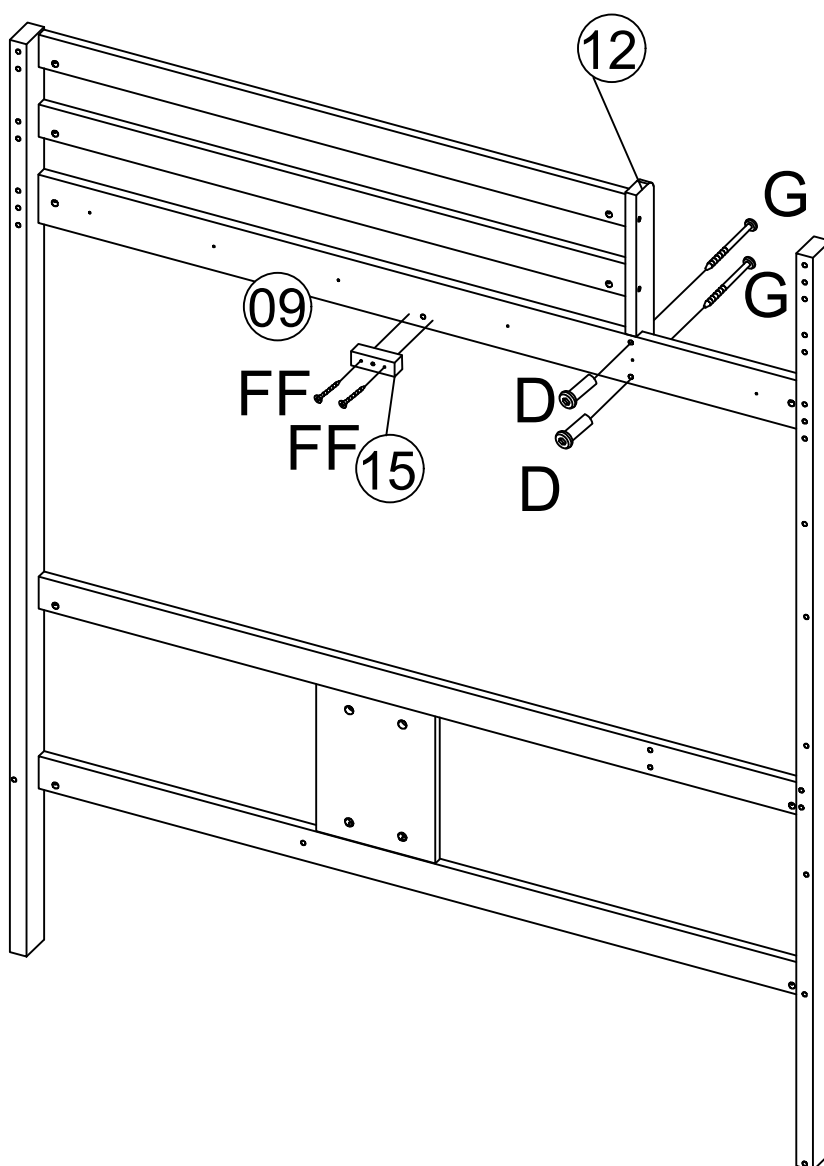

A	6*70		8PCS								
B			10PCS	AA	M4		1PC	F	6*60		2PCS
C	8*30		12PCS	I			4PCS	J			4PCS

ASSEMBLY INSTRUCTIONS

2









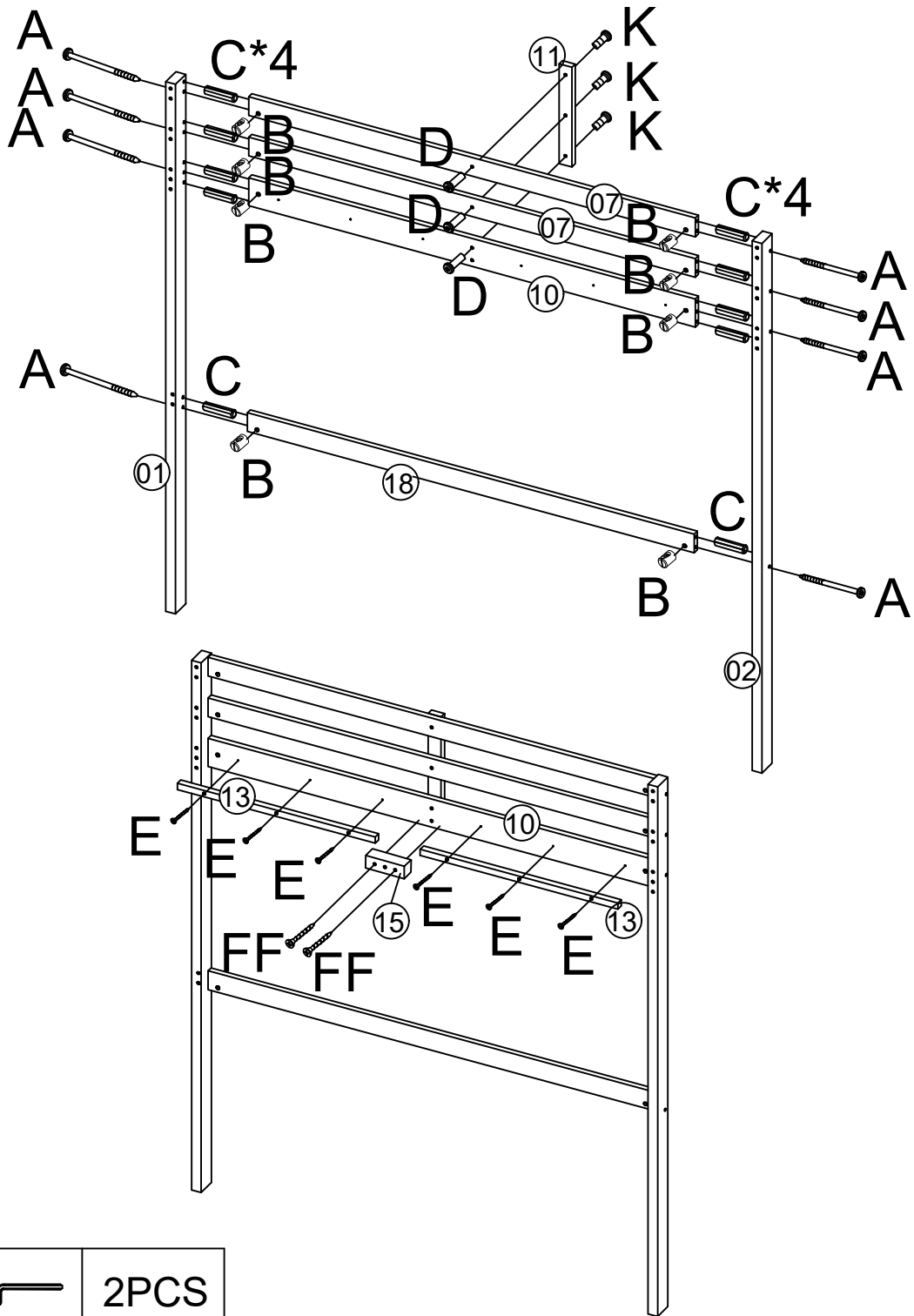

D	8*20		2PCS								
FF	4*35		2PCS	G	6*50		2PCS	AA	M4		2PCS

ASSEMBLY INSTRUCTIONS

3



AA	M4		2PCS								
A	6*70		8PCS								
B			8PCS	D	8*20		3PCS	FF	4*35		2PCS
C	8*30		10PCS	K	6*30		3PCS	E	4*30		6PCS

ASSEMBLY INSTRUCTIONS

5

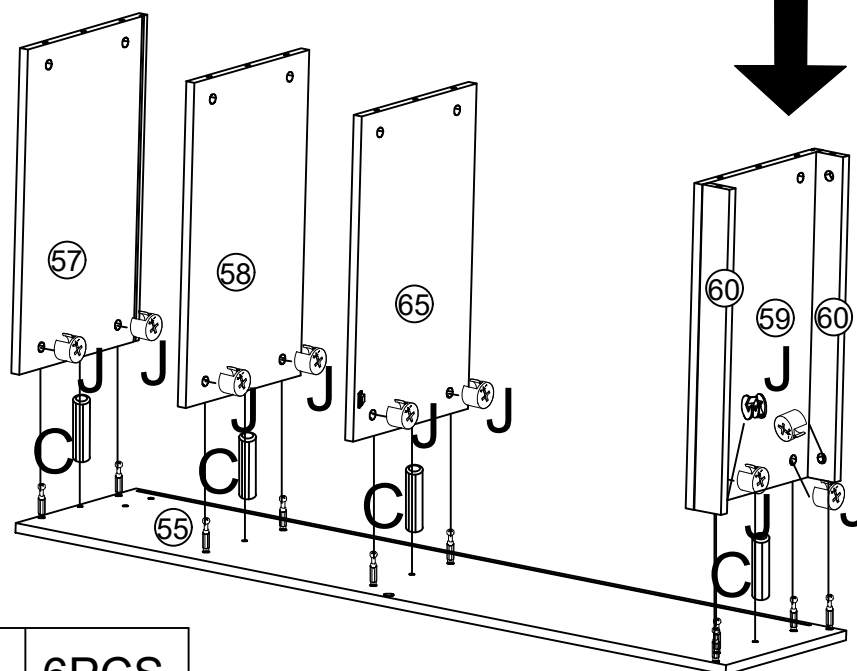
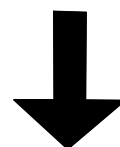
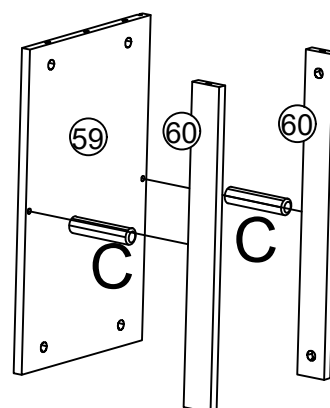
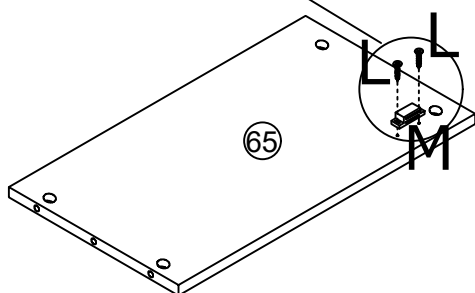
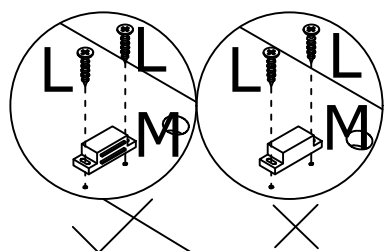
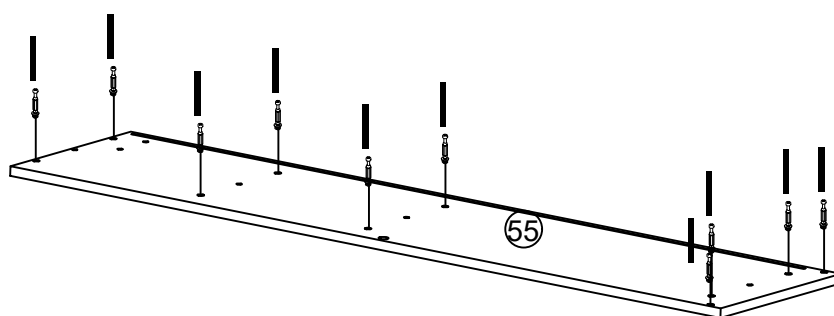

C	8*30		6PCS
I			10PCS
J			10PCS
L	3*14		2PCS
M			1PC

ASSEMBLY INSTRUCTIONS

6

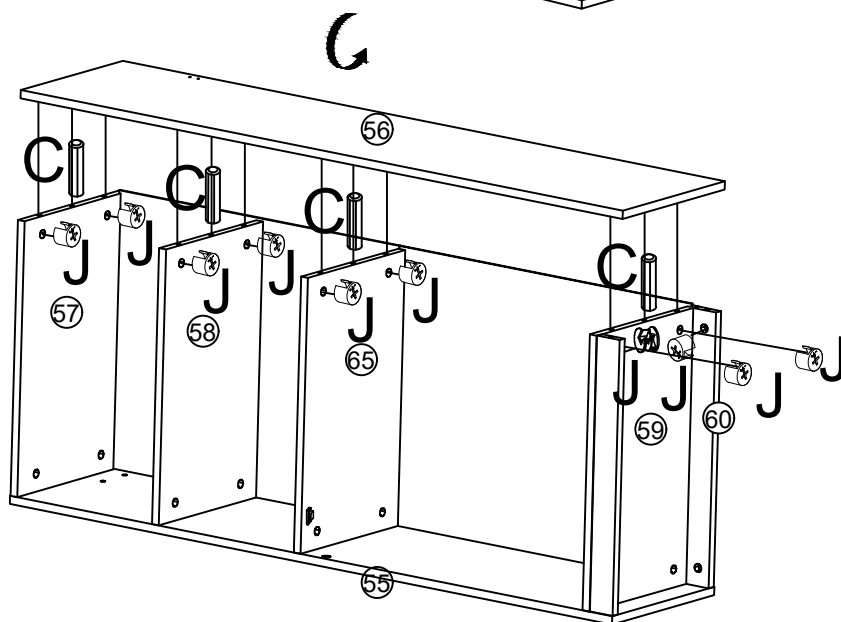
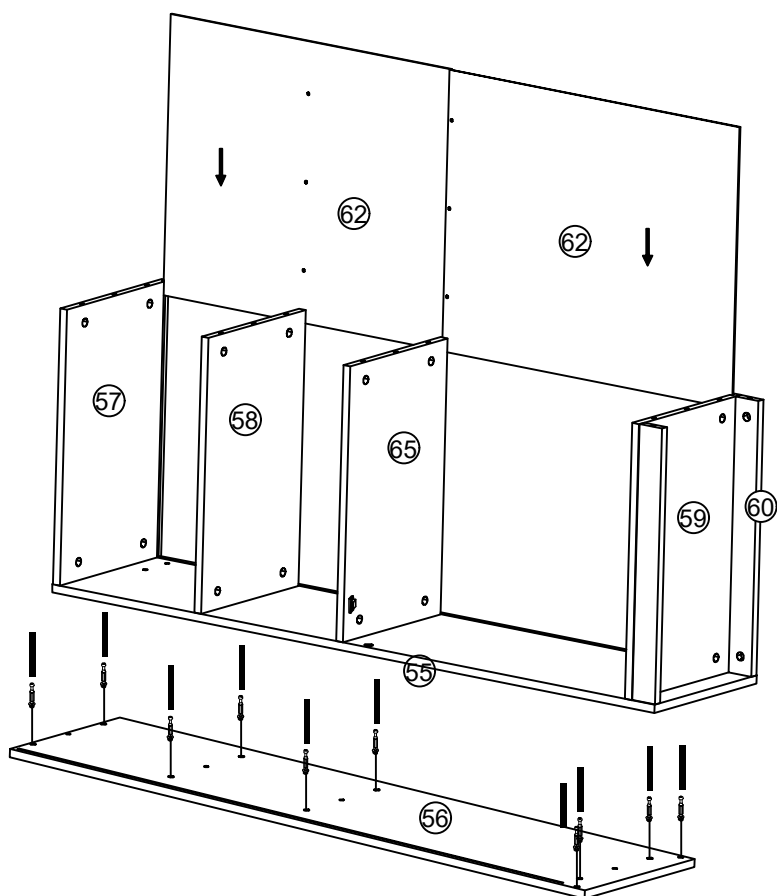

C 8*30 

4PCS

I

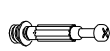

10PCS

J



10PCS

ASSEMBLY INSTRUCTIONS

7

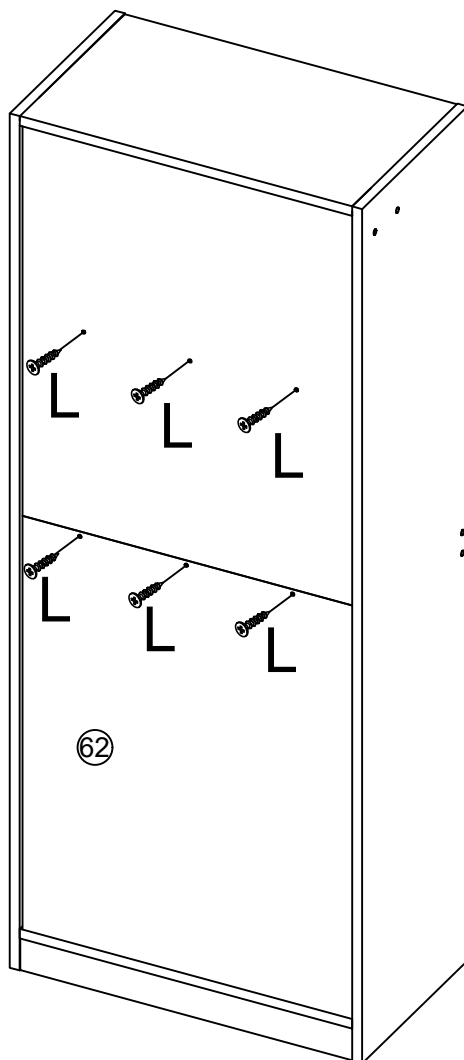

L 3*14



6PCS

ASSEMBLY INSTRUCTIONS

8

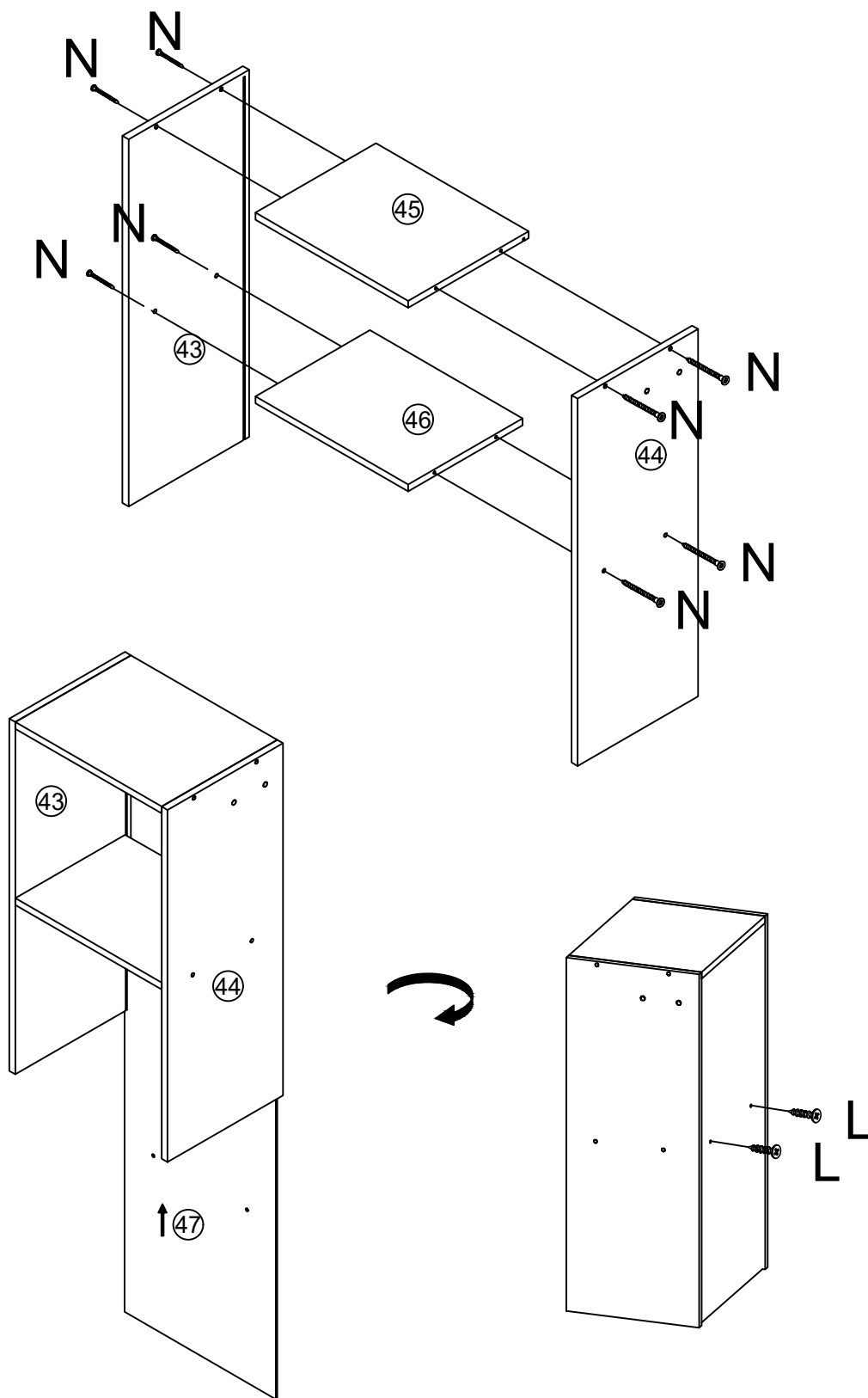

L 3*14



2PCS

N 5*40



8PCS

BB

M3





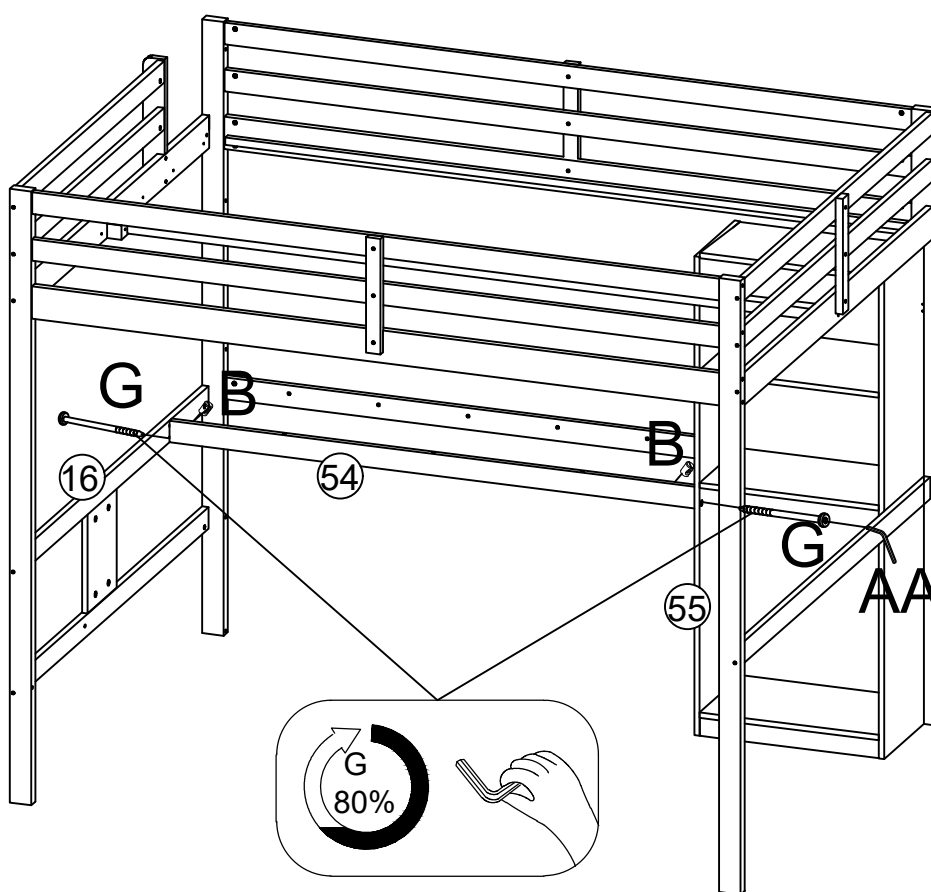
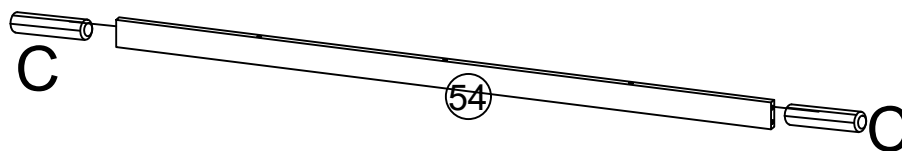

1PC

ASSEMBLY INSTRUCTIONS

9





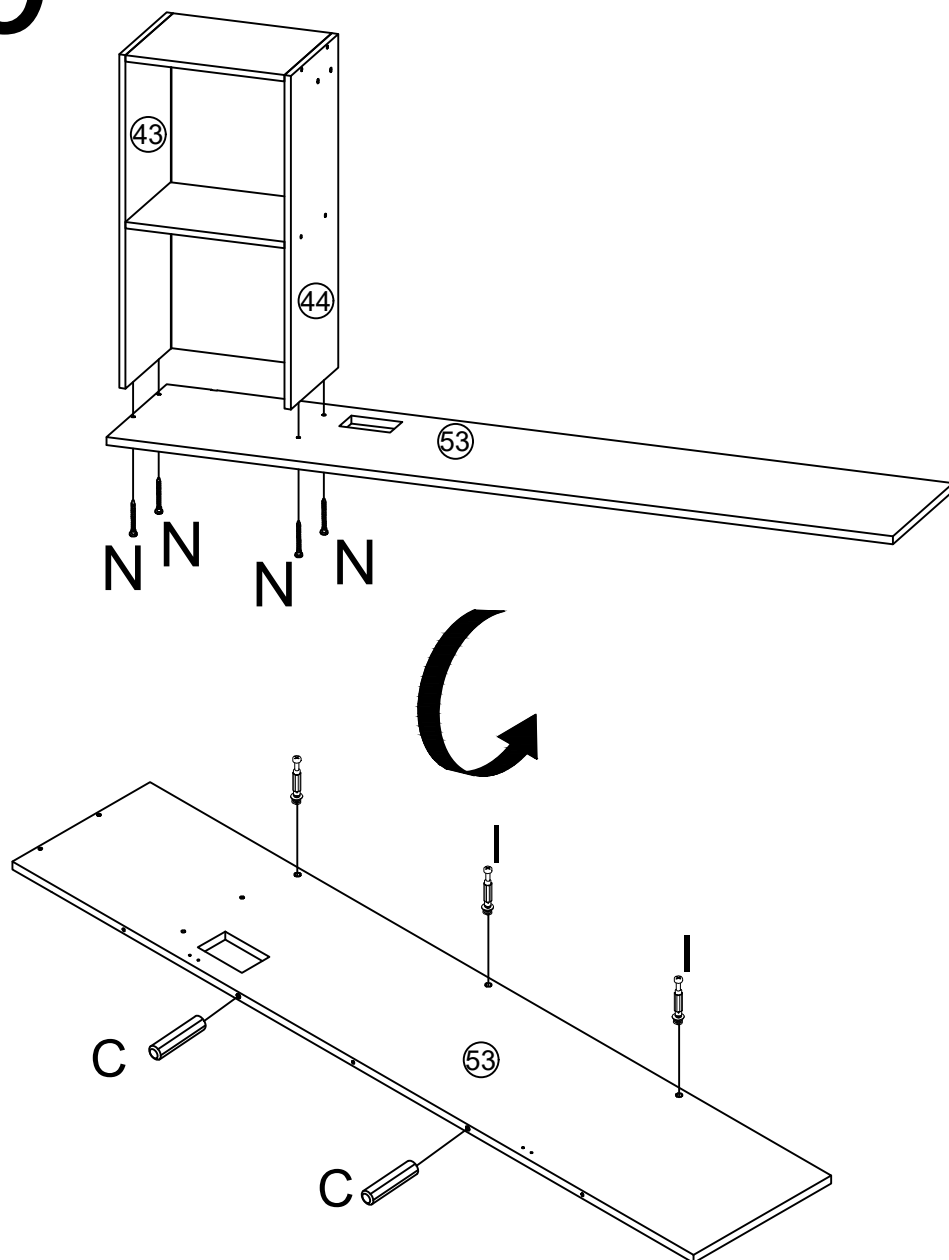

AA	M4		1PC
B			2PCS
C	8*30		2PCS
G	6*50		2PCS

ASSEMBLY INSTRUCTIONS

10



BB	M3		1PC				
C	8*30		2PCS	I		3PCS	N 5*40  4PCS

ASSEMBLY INSTRUCTIONS

11

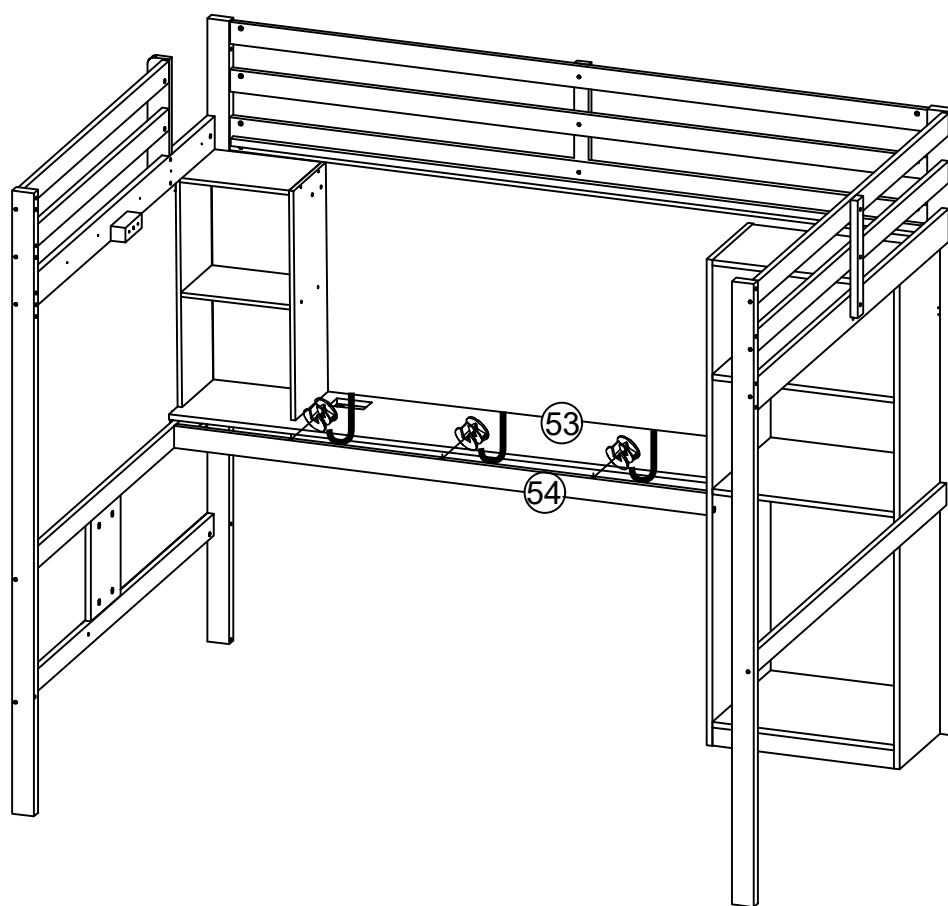

J





3PCS

ASSEMBLY INSTRUCTIONS

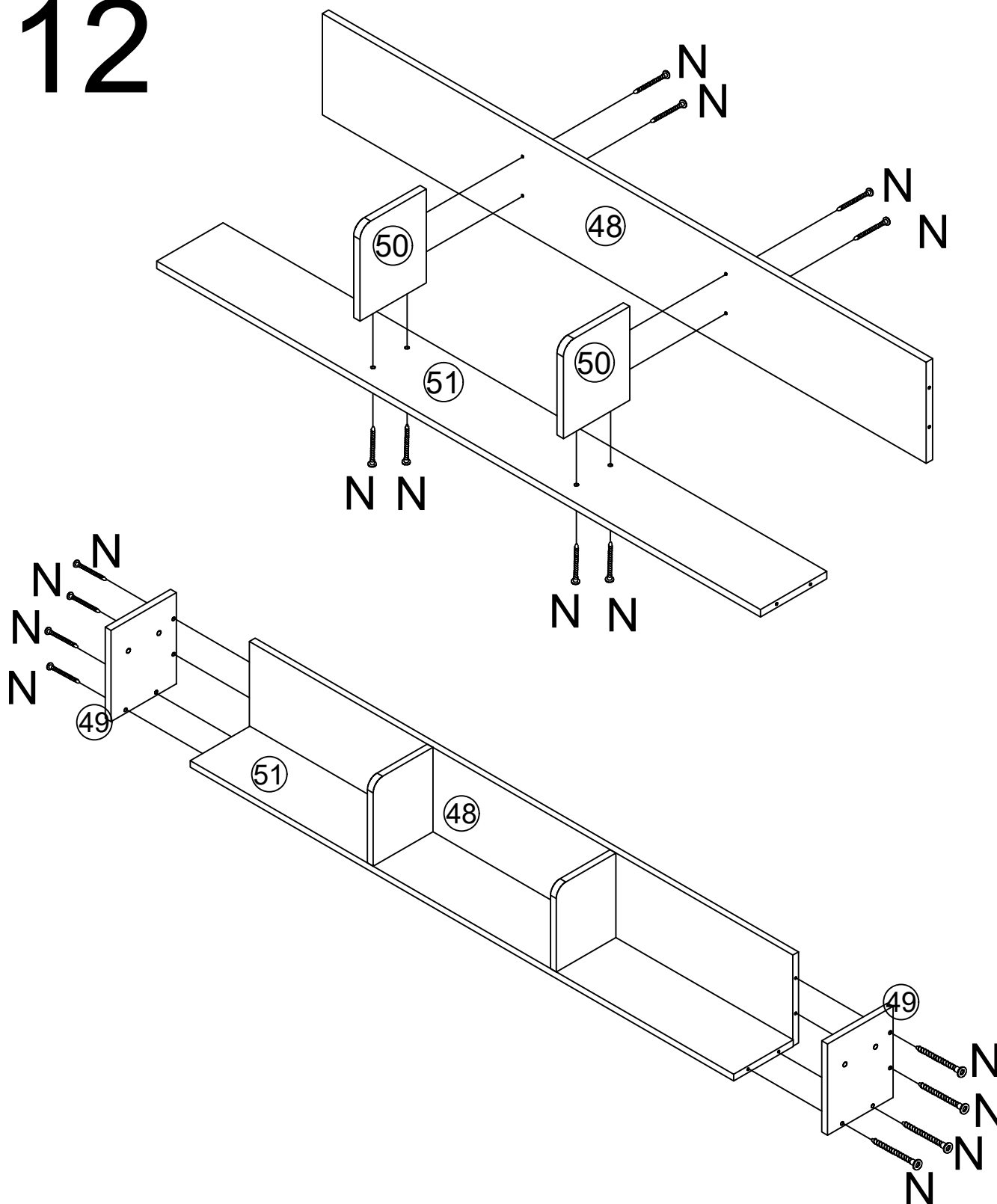
12



BB	M3		1PC
N	5*40		16PCS

ASSEMBLY INSTRUCTIONS

13

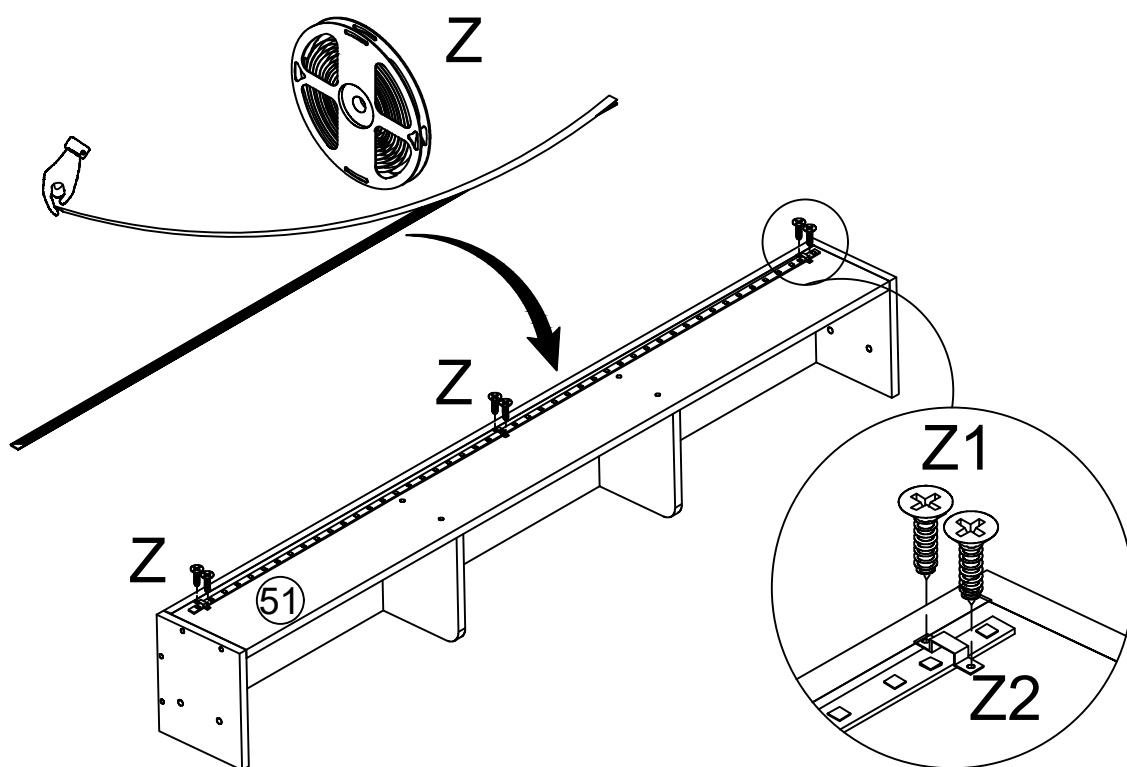

Z





1PC

ASSEMBLY INSTRUCTIONS

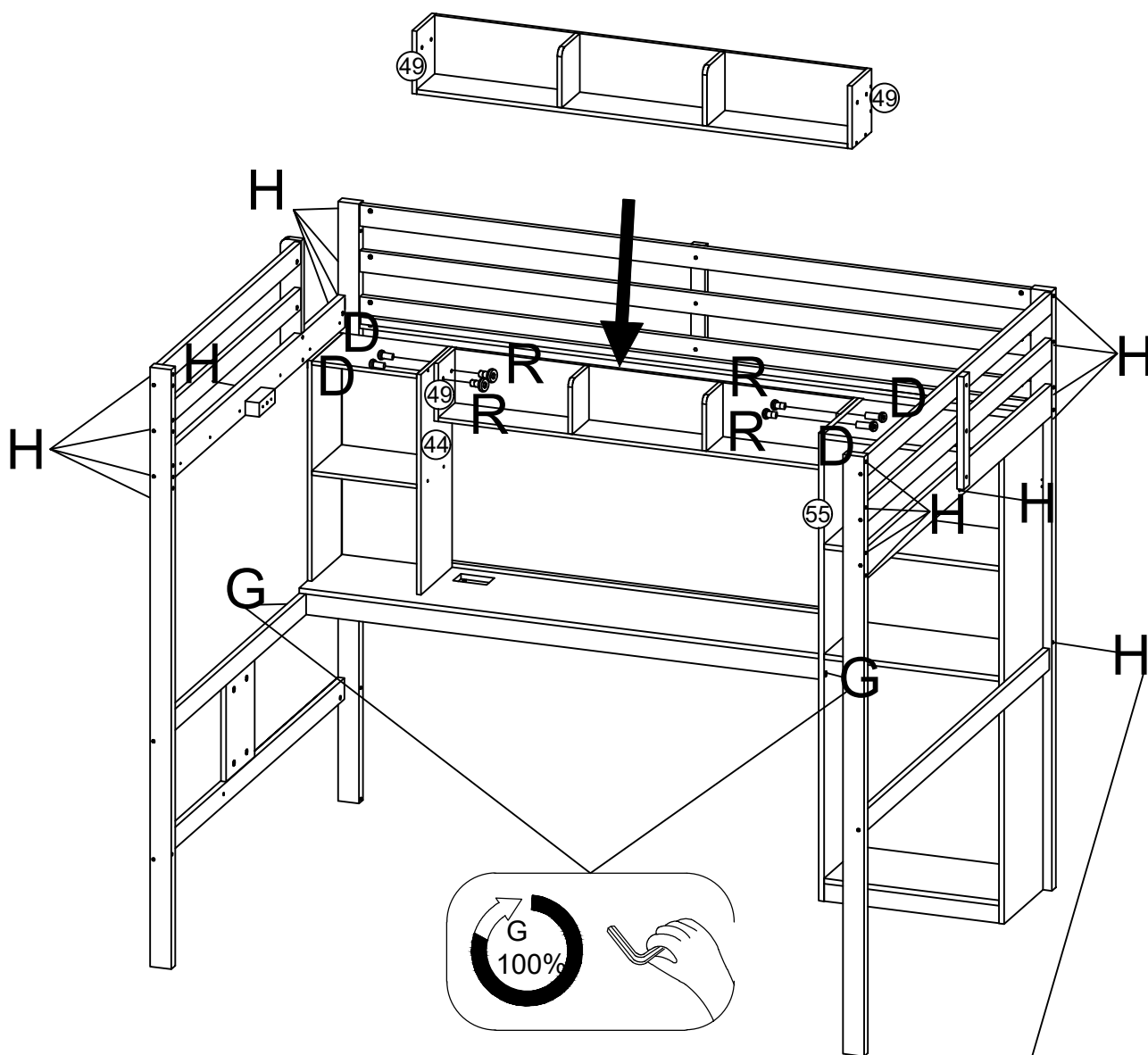
14



AA _{M4}		2PCS
D 8*20		4PCS
R 6*15		4PCS

ASSEMBLY INSTRUCTIONS

15

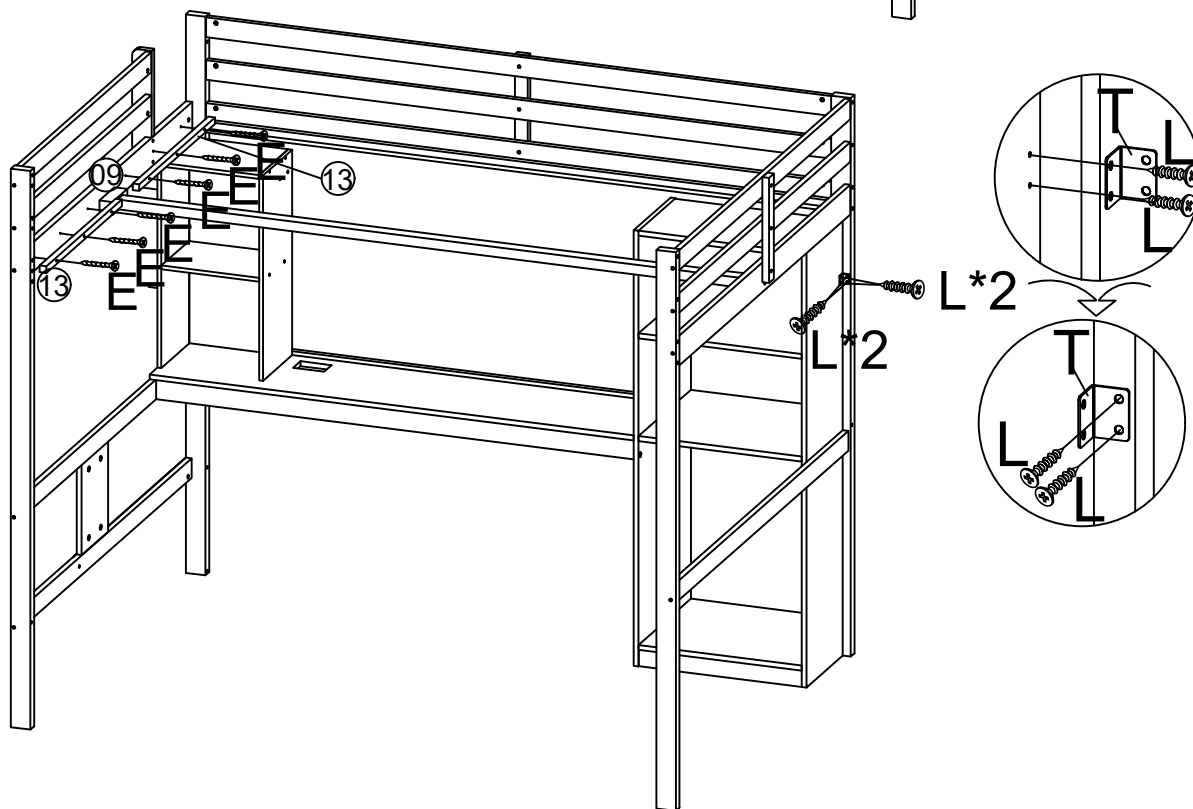
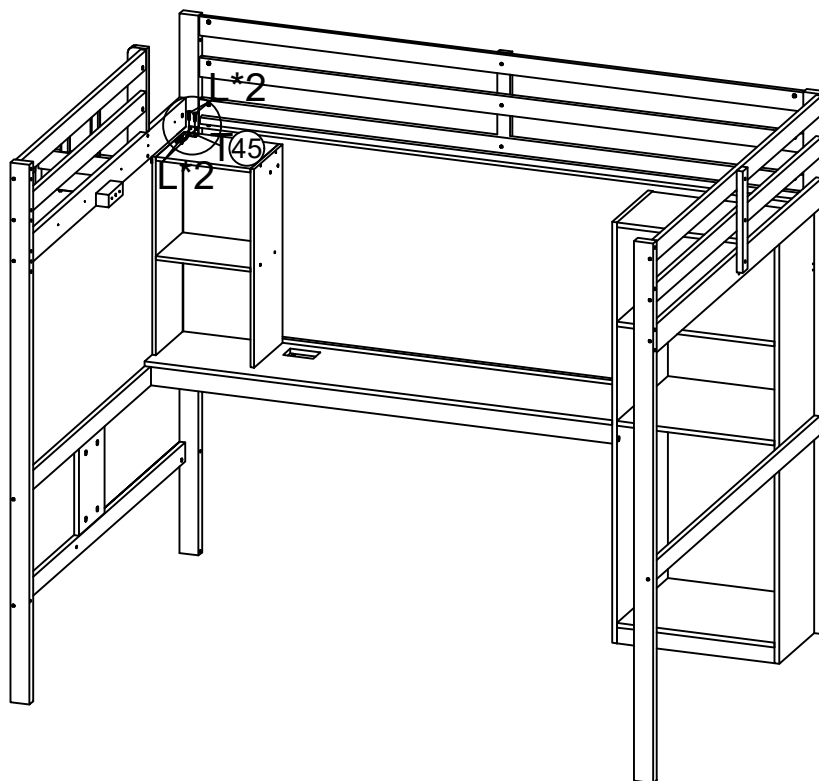
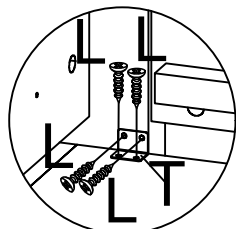

E	4*30		6PCS	L	3*14		8PCS	T		2PCS
---	------	---	------	---	------	---	------	---	---	------

ASSEMBLY INSTRUCTIONS

16

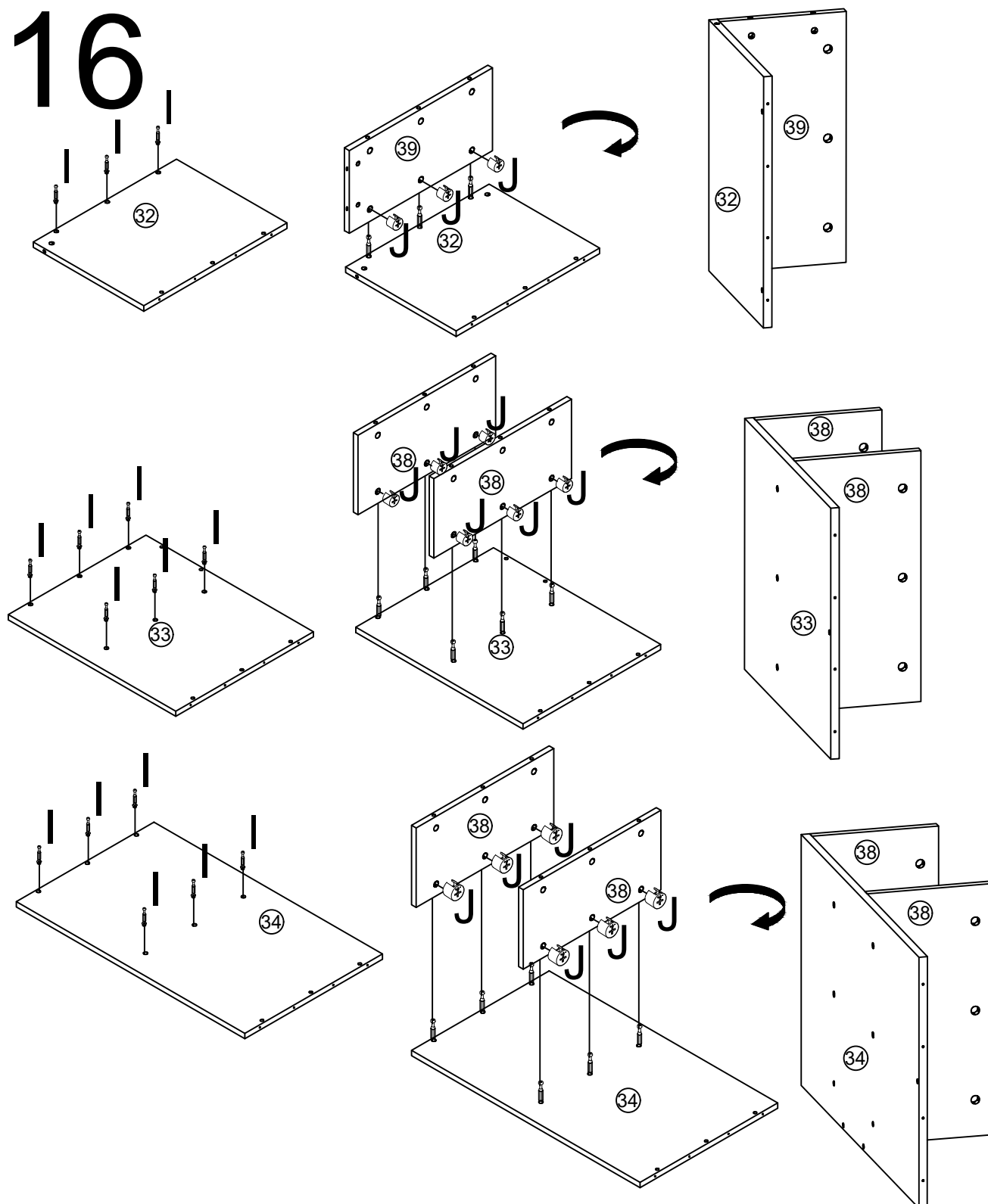

I



15PCS

J





15PCS

ASSEMBLY INSTRUCTIONS

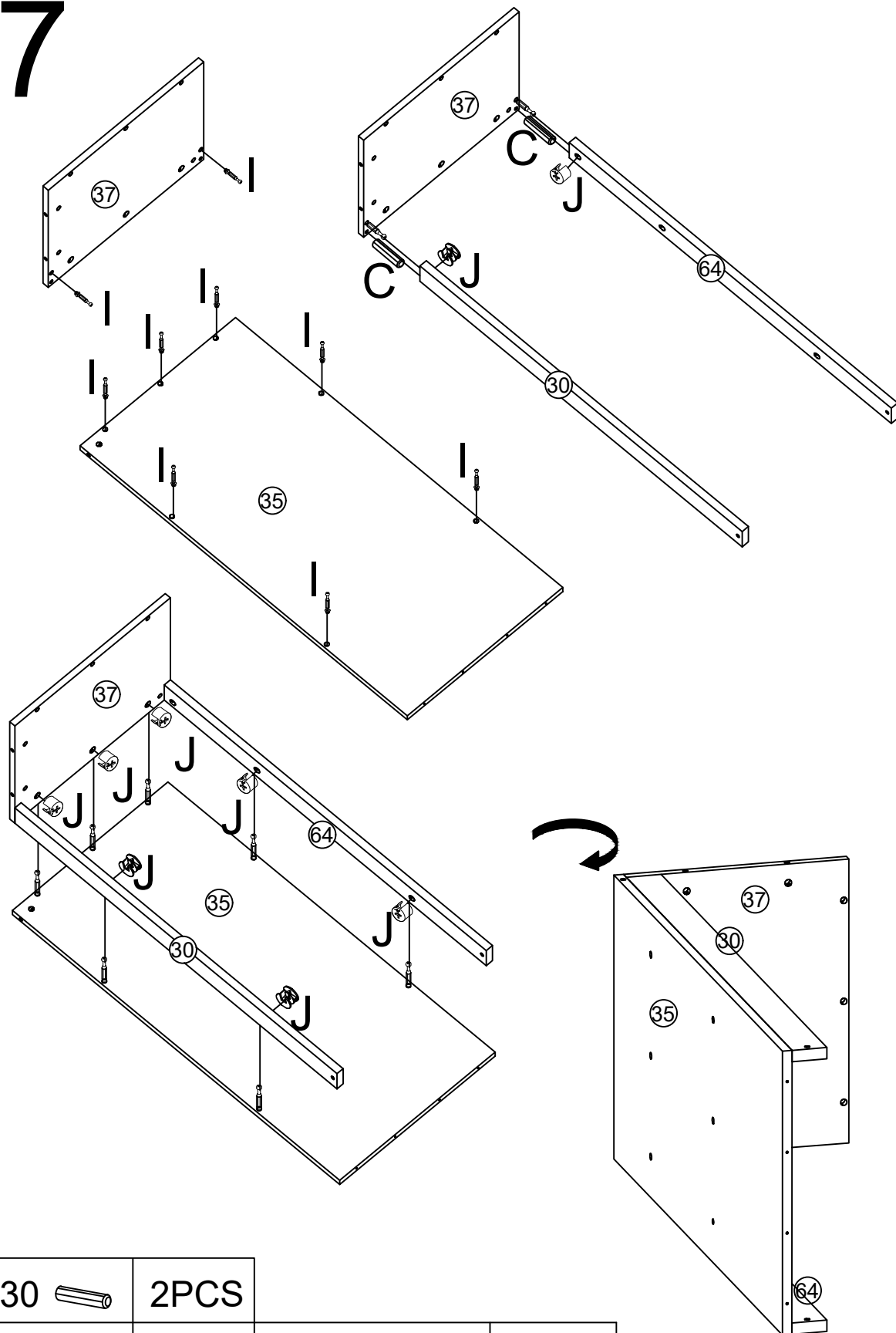
17





C	8*30		2PCS
I			9PCS
J			9PCS

ASSEMBLY INSTRUCTIONS

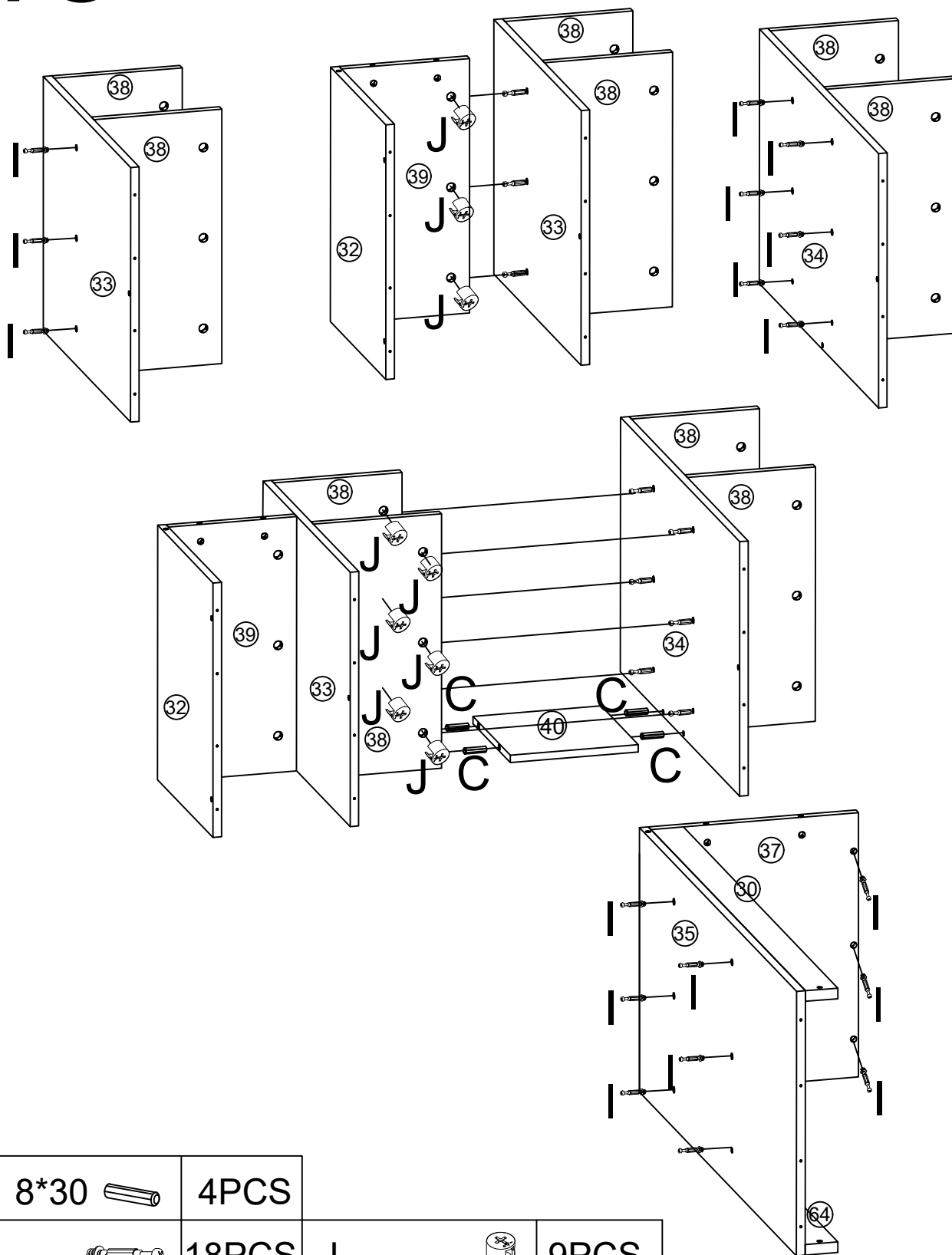
18







C	8*30 	4PCS
I		18PCS

J		9PCS
---	---	------

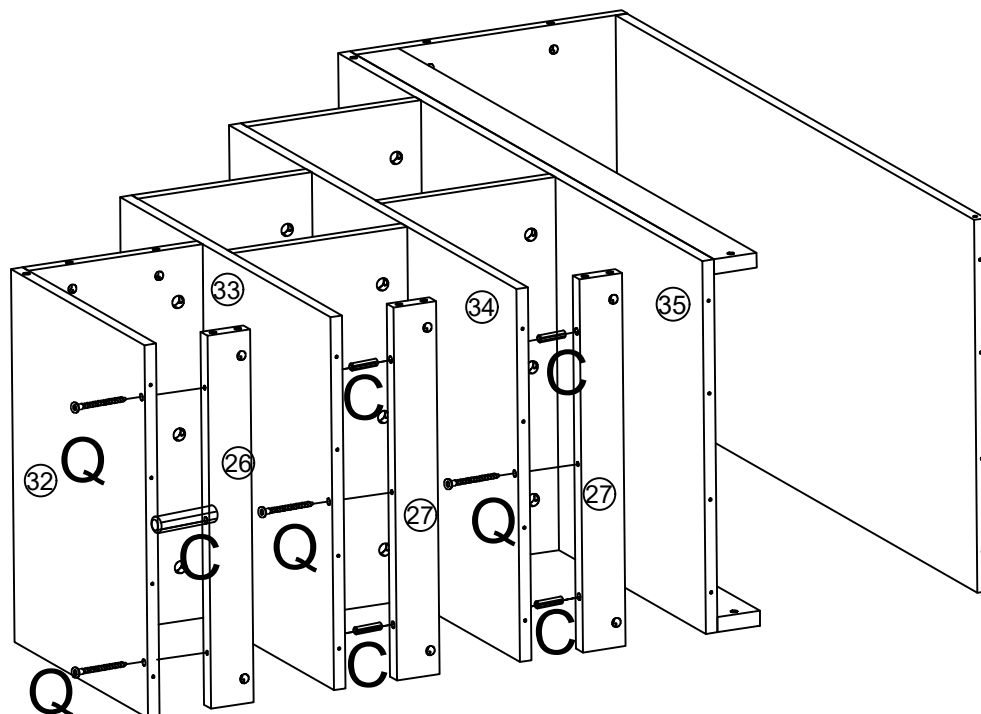
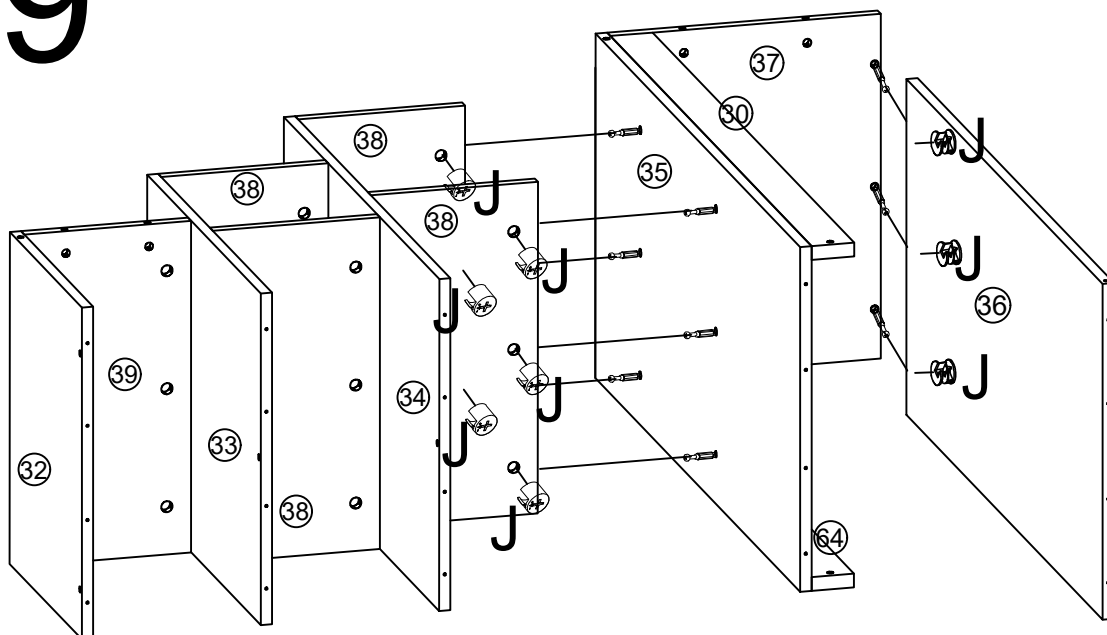
ASSEMBLY INSTRUCTIONS

19





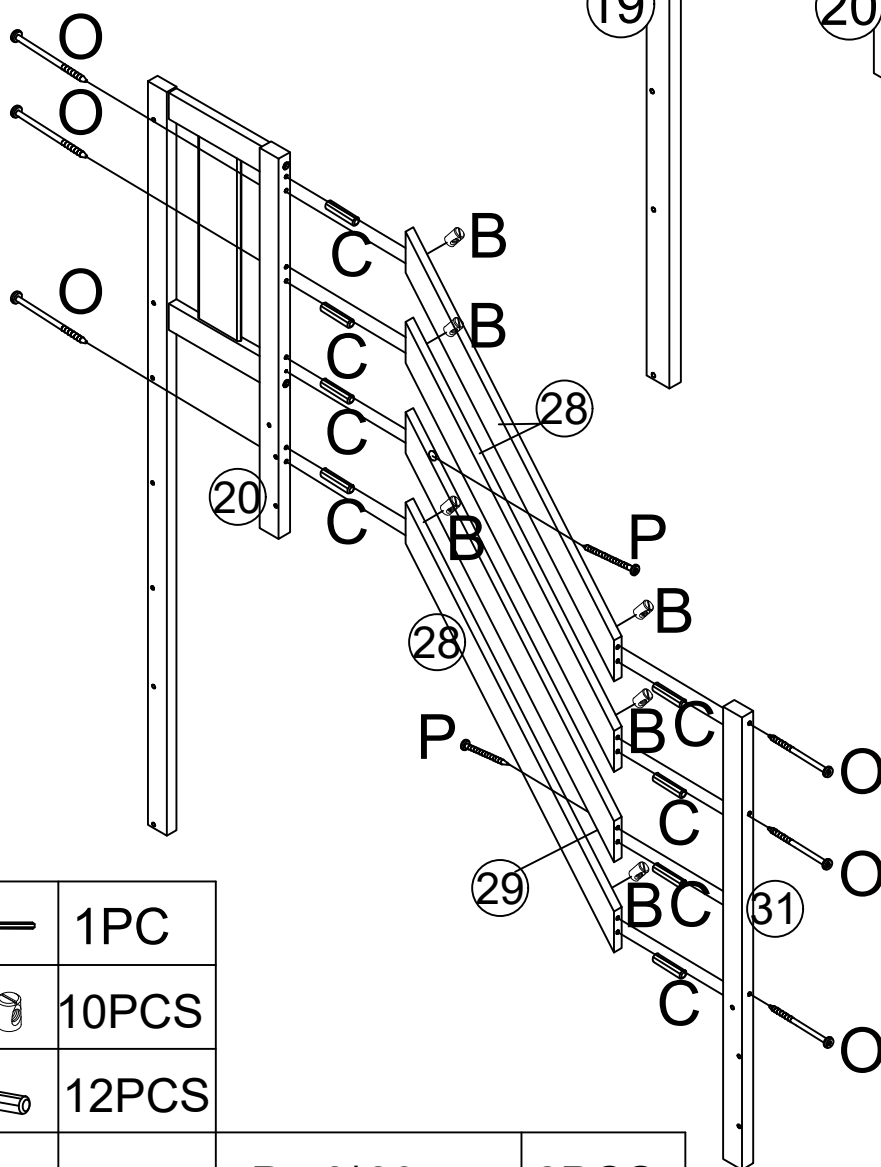
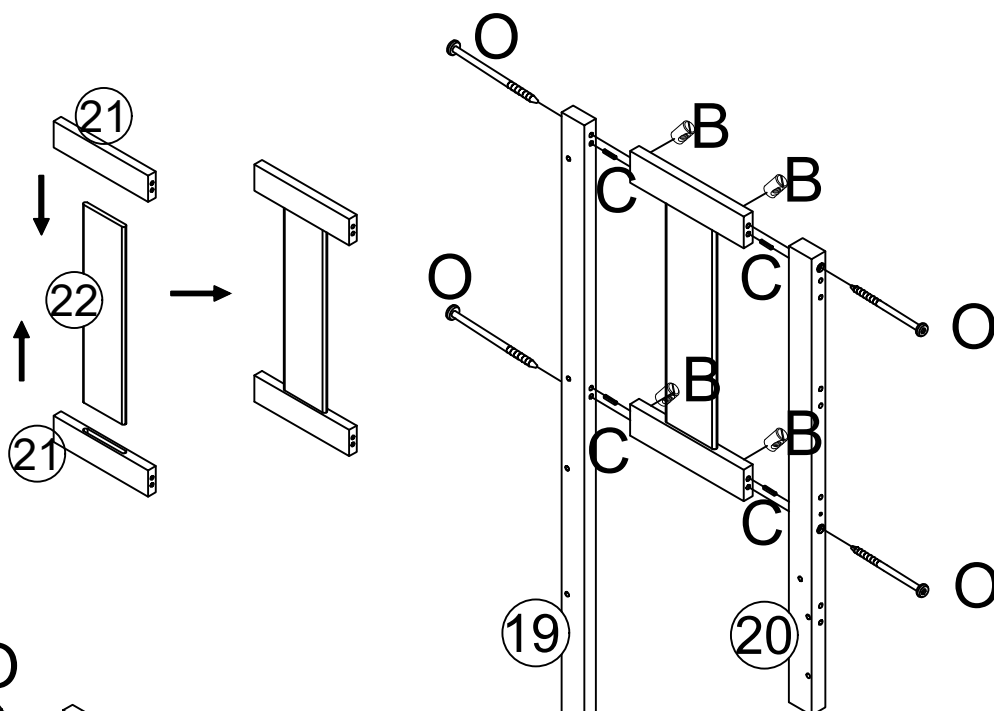

C	8*30		5PCS
J			9PCS
Q	7*50		4PCS

ASSEMBLY INSTRUCTIONS

20







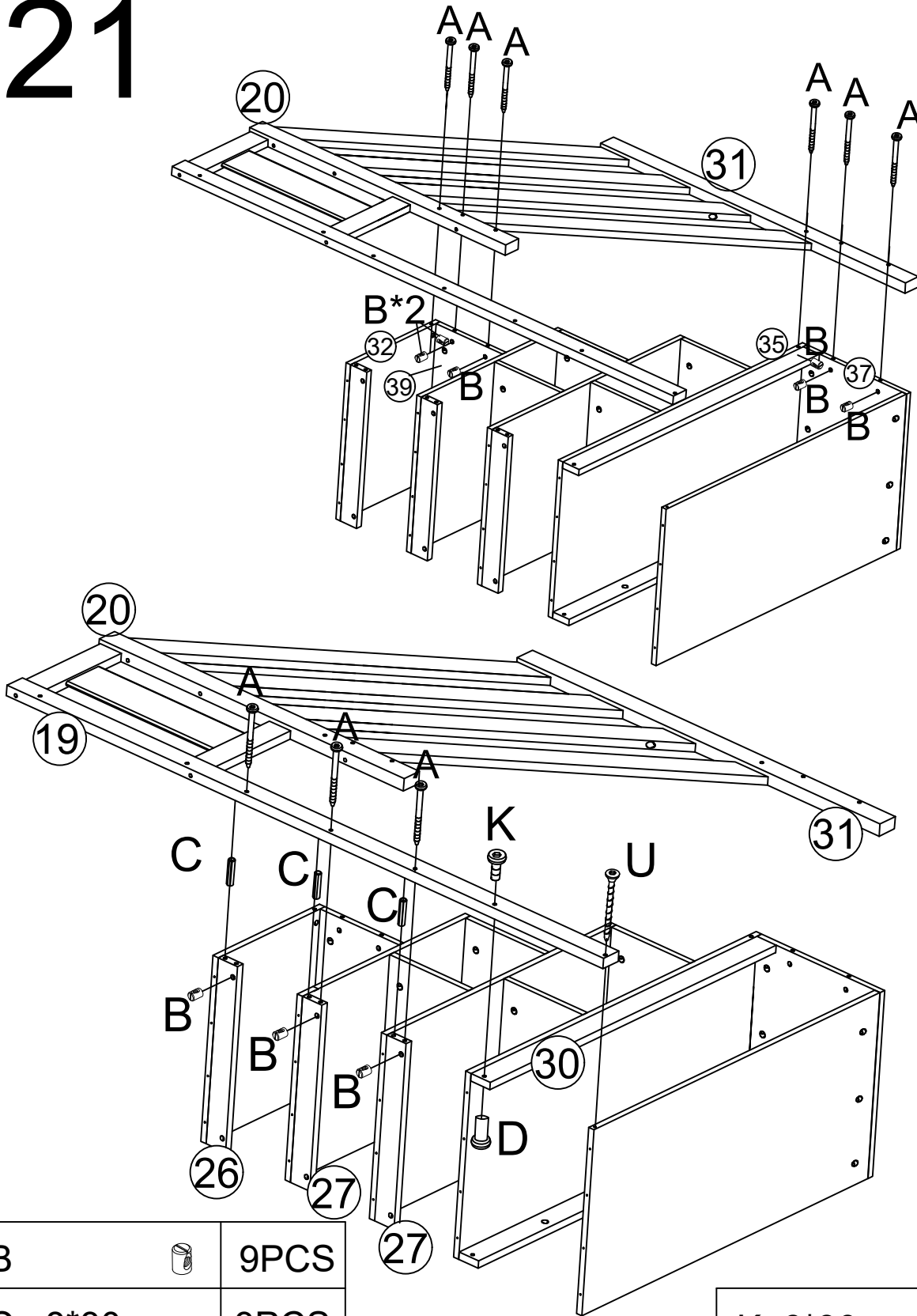

AA M4		1PC		
B		10PCS		
C 8*30		12PCS		
O 6*90		10PCS	P 6*80	 2PCS

ASSEMBLY INSTRUCTIONS

21







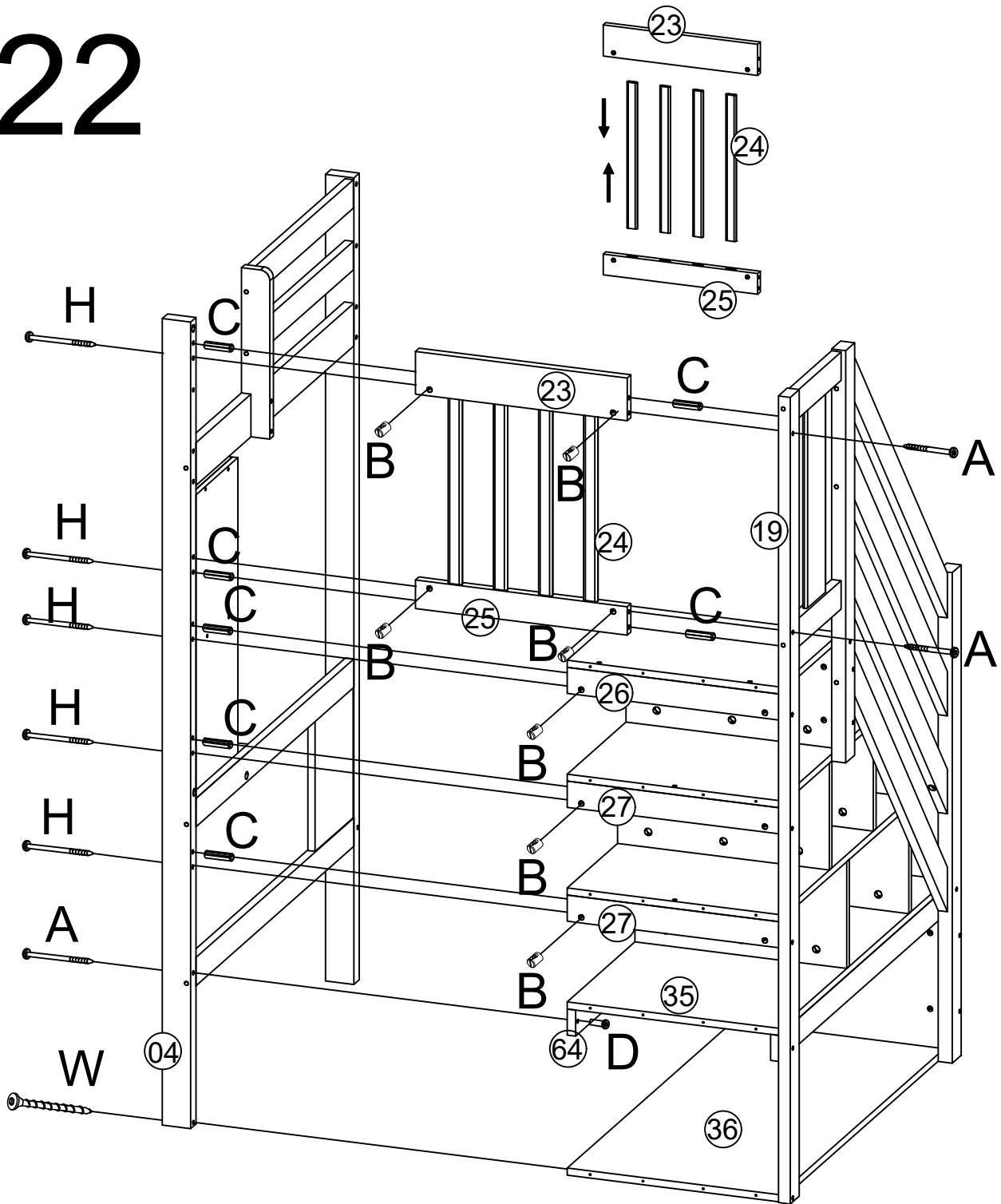

B		9PCS		
C	8*30 	3PCS		
D	8*20 	1PC	A	6*70  9PCS
			K	6*30  1PC
			U	6*70  1PC

ASSEMBLY INSTRUCTIONS

22



AA M4		2PCS						
A 6*70		3PCS	C 8*30		7PCS	D 8*20		1PC
B		7PCS	H 6*100		5PCS	W 6*100		1PC

ASSEMBLY INSTRUCTIONS

23

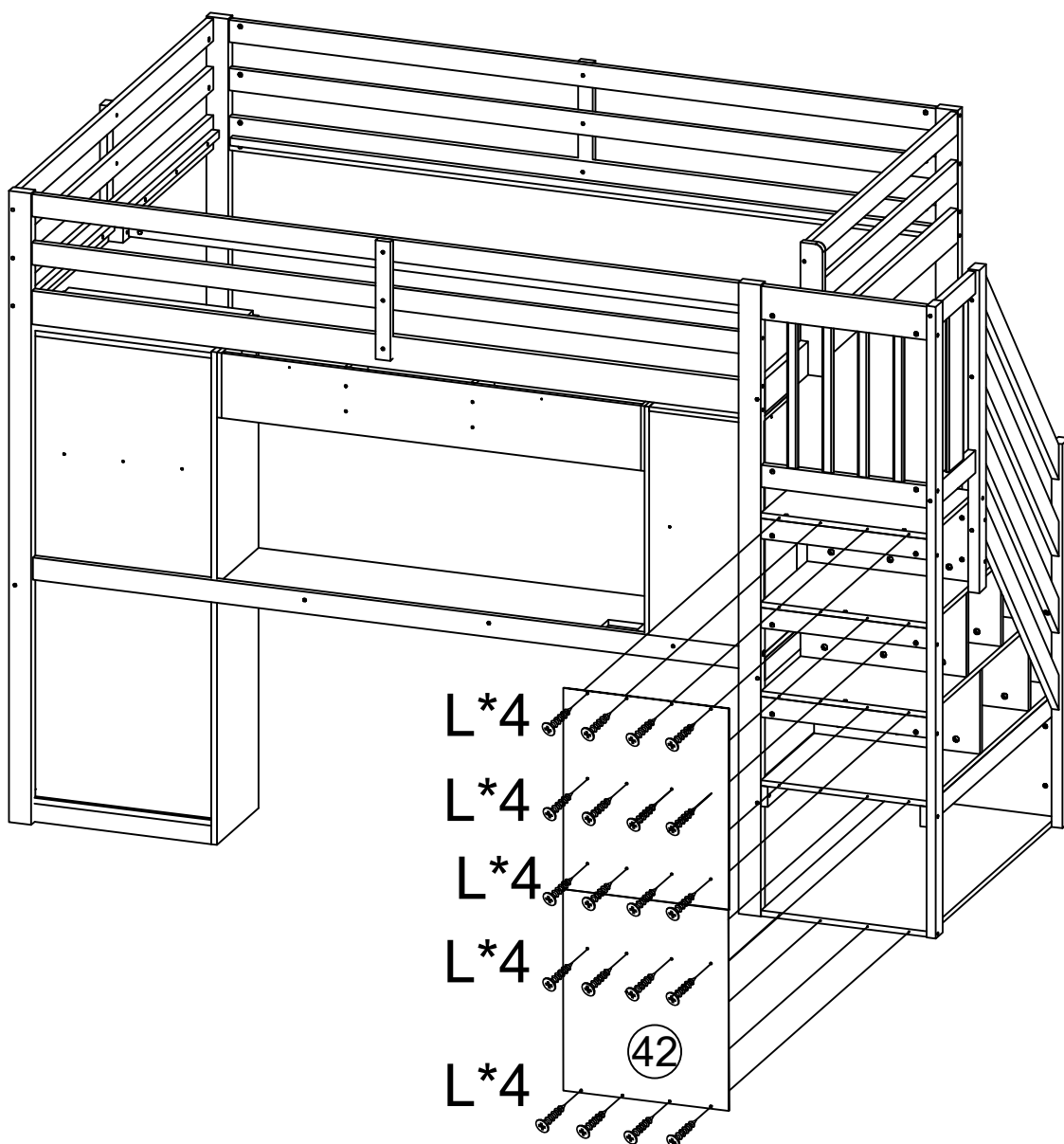



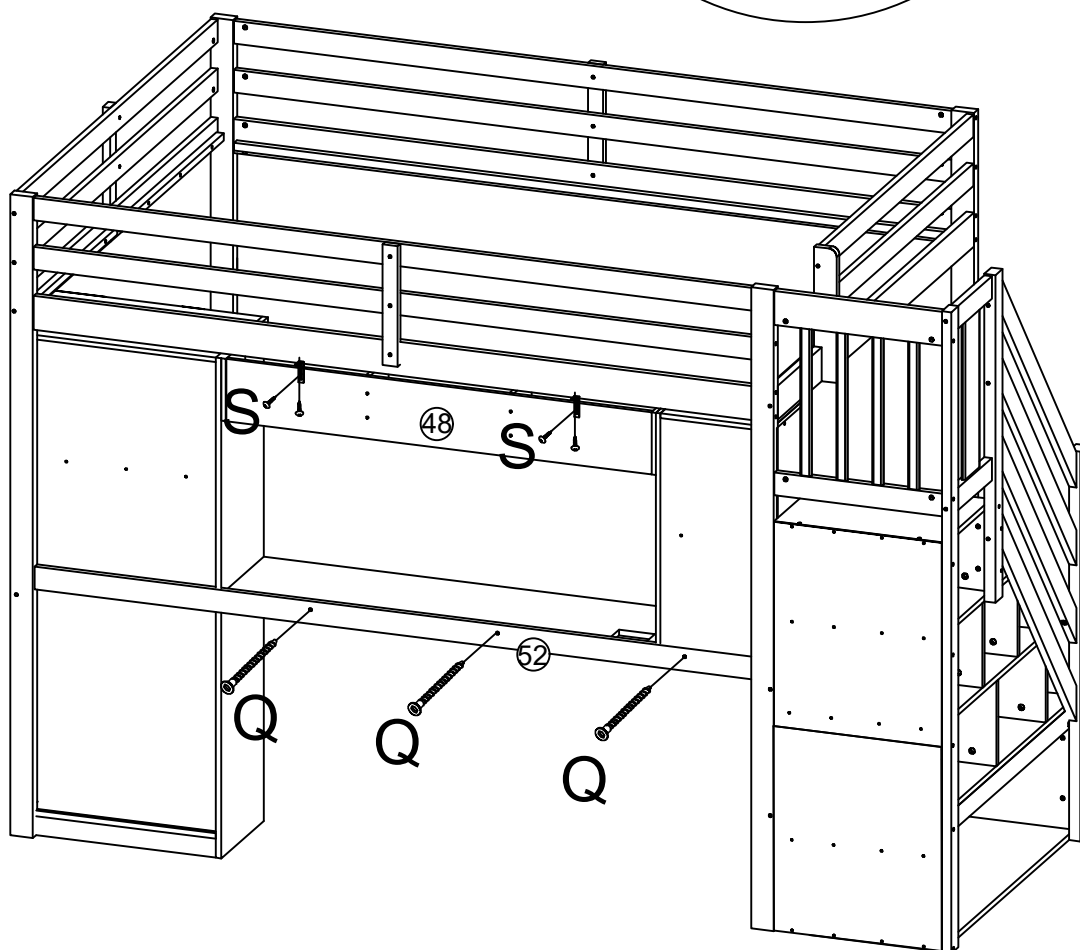
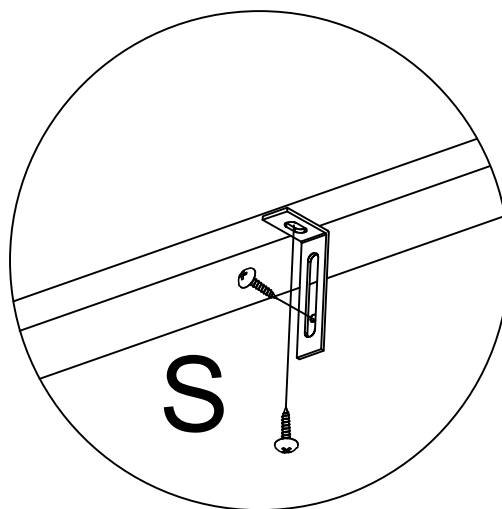

L 3*14		20PCS
--------	---	-------

ASSEMBLY INSTRUCTIONS

24



BB	M3		1PC
----	----	---	-----

S			2PCS	Q	$\text{Ø}7*50$		3PCS
---	---	---	------	---	----------------	---	------

ASSEMBLY INSTRUCTIONS

25

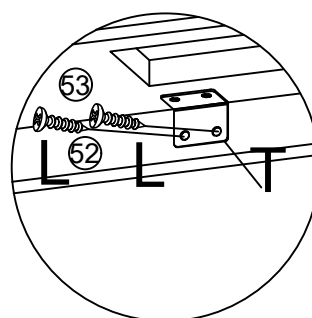
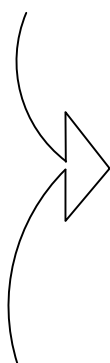
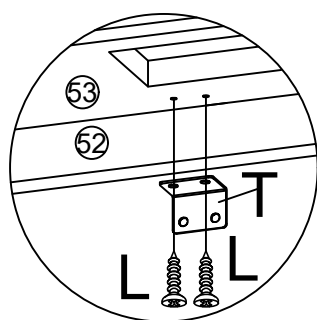
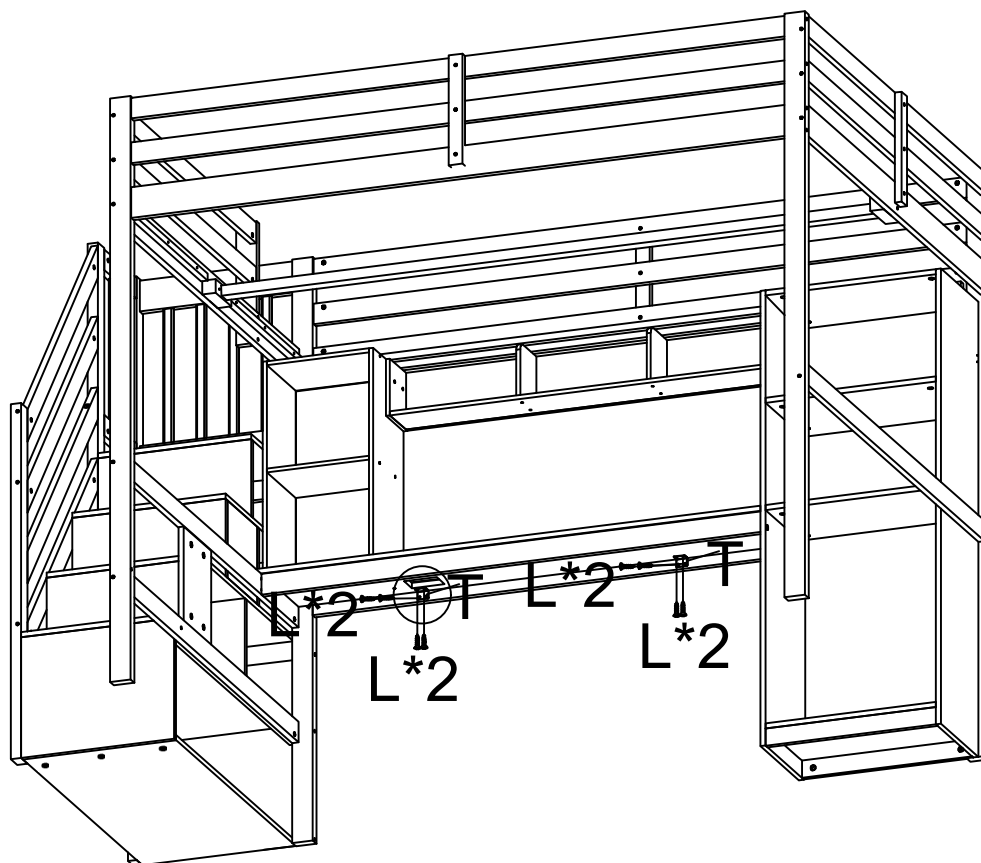

L 3*14



8PCS

T



2PCS

ASSEMBLY INSTRUCTIONS

26

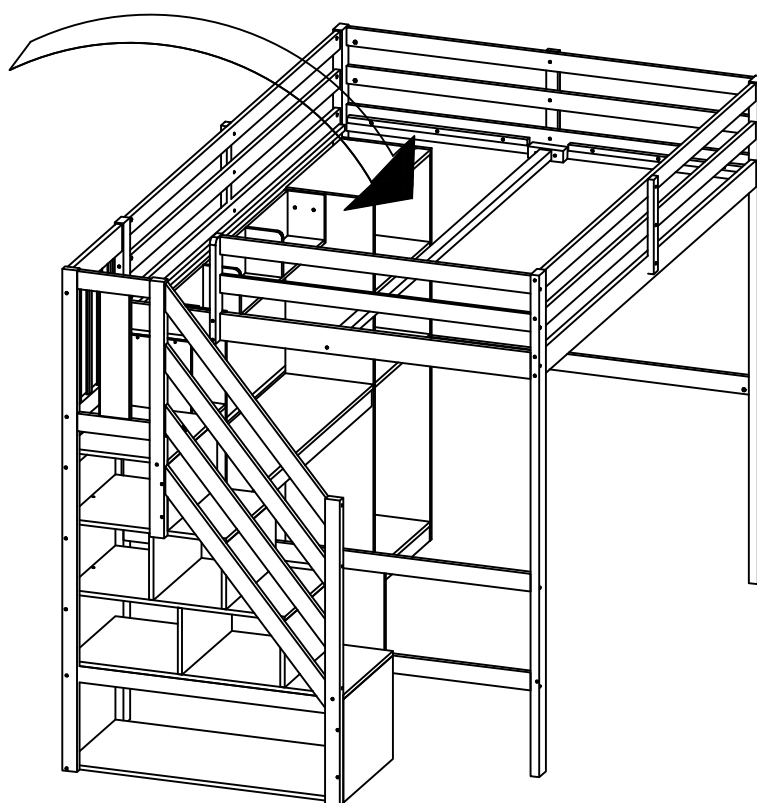
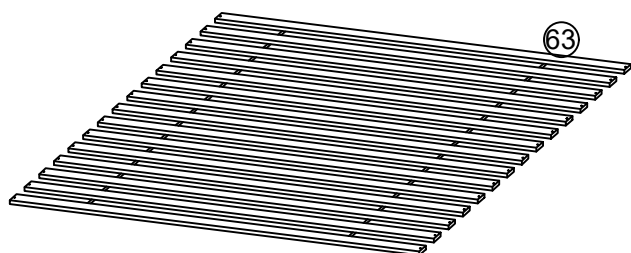

ASSEMBLY INSTRUCTIONS

27

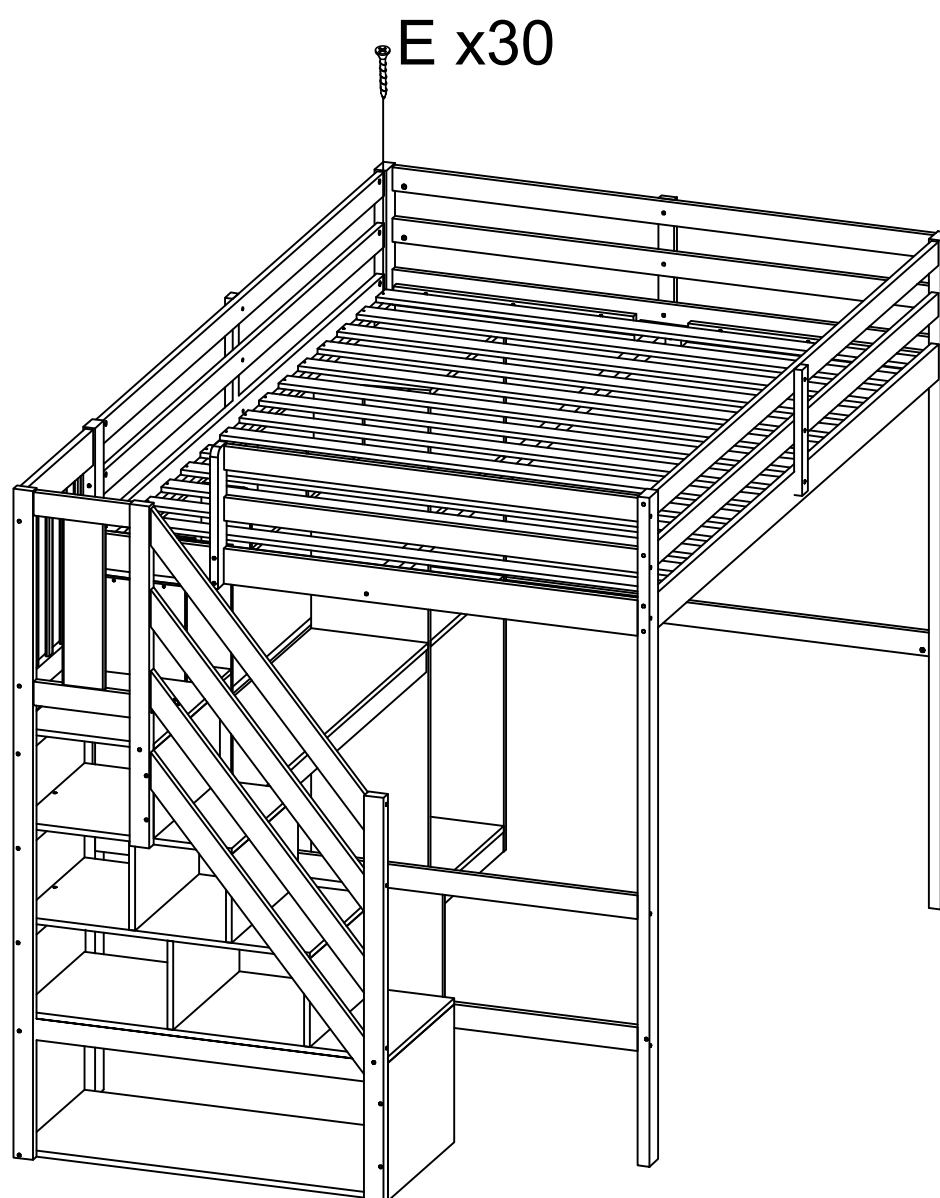



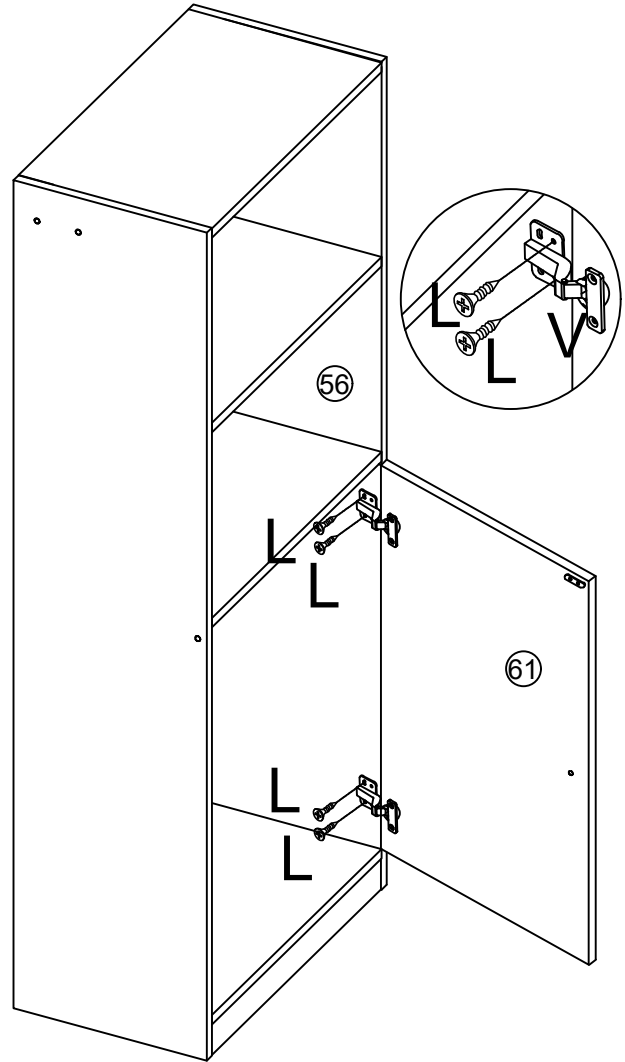
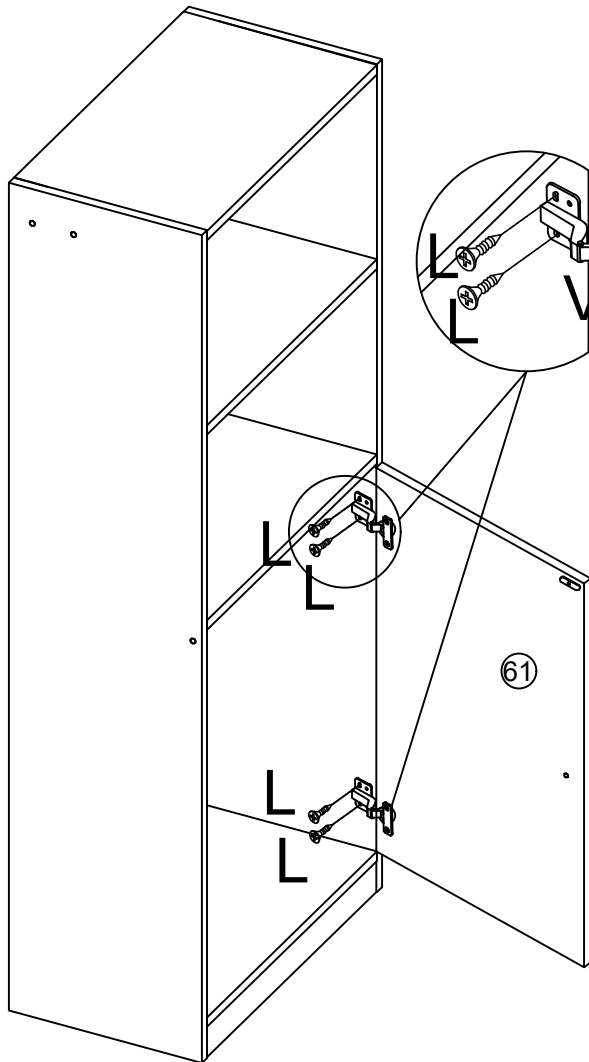
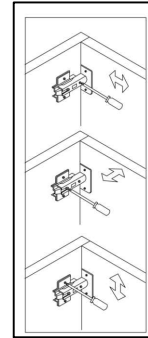
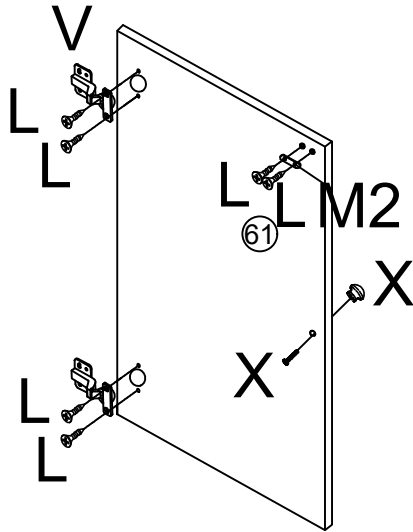

E 4*30  30PCS

ASSEMBLY INSTRUCTIONS

28





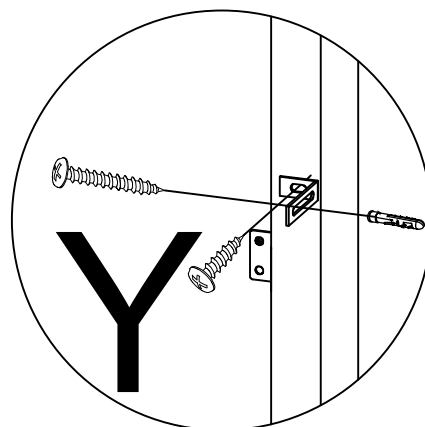
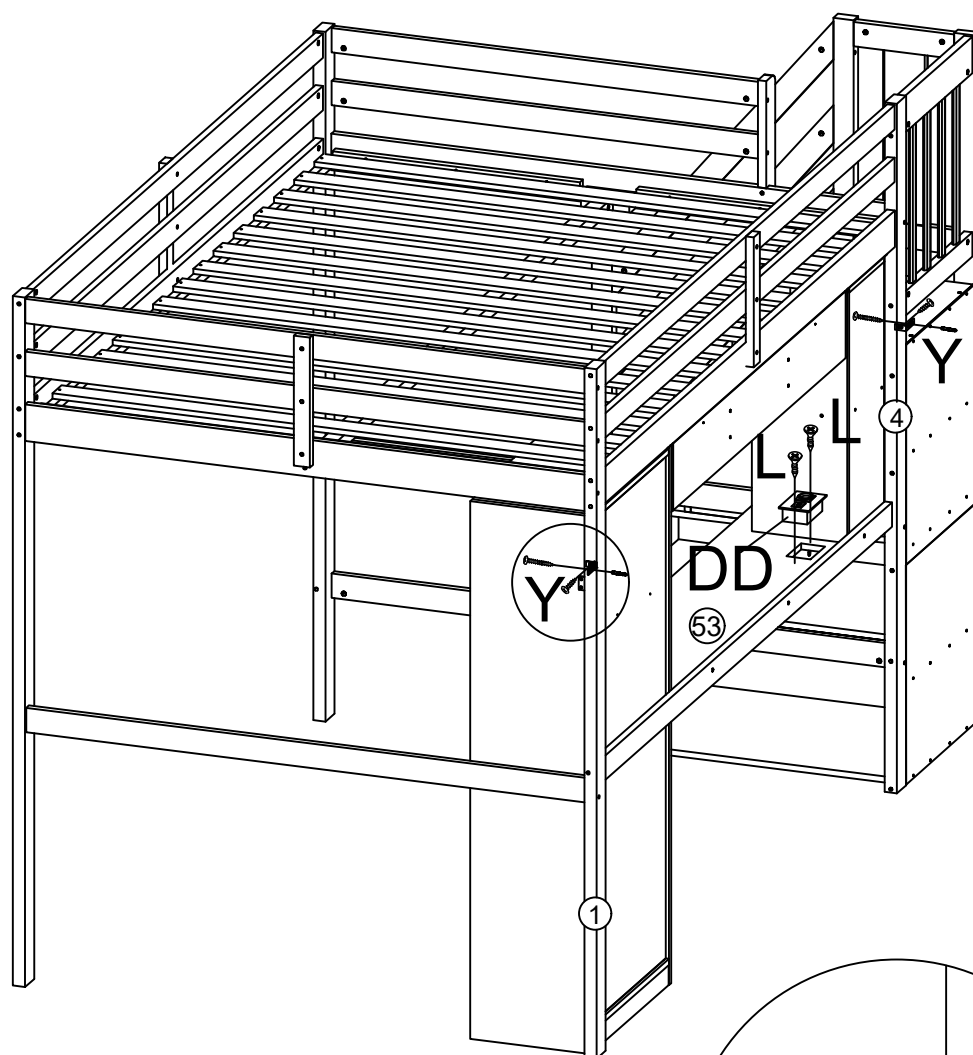

L	3*14		14PCS						
V			2PCS	M		1PC	X		1PC

ASSEMBLY INSTRUCTIONS

29



L	3*14		2PCS	Y			2PCS	DD		1PC
---	------	---	------	---	---	---	------	----	---	-----

LED mobile phone Bluetooth controller



Scan two-dimensional code download APP

- ① Connect LED color strip and controller, power on controller
- ② Scan two-dimensional code download APP:



- ③ Start APP, search and connect controller
- ④ Enjoy the Bluetooth wireless control experience

APP Program Usage



Notes:
detailed operating instructions, enter the menu "Guide":



LED mobile phone Bluetooth controller

Product Features

- LED Bluetooth controller is directly via mobile phone control remote distance can reach 20m without the need to set up, easy to connect open the software within 5 seconds you can automatically connect the controller
- Flow the rhythm of the music changes
- Group control
- Brightness, speed addition and subtraction
- Maximum can be 10 meters RGB(W) strip
- The software shows that the text is based on the language of the mobile phone set up automatic transformation of Chinese and English

Animation Effect:

- Colorful gradient
- All kinds of monochrome, double color gradient
- All kinds of monochrome, double color, colorful flashing
- Colorful jump
- Follow the rhythm of the music changes

Product Parameters:

- Bluetooth: BLE V4.2
- Input Voltage: 4.5~26V
- Working Temp: -25~75°C
- Size: 43*22*11mm
- Weight: 30g
- Max Power: 144W(24V)



Reference No. : WTX24X07163344E
 Applicant : Shenzhen Yicaiju Photoelectric Technology Co., LTD
 201, Building 011, Shangyan Second Industrial Zone,
 Address : Shangcun Community, Gongming Street, Guangming
 District, Shenzhen
 Manufacturer : Shenzhen Yicaiju Photoelectric Technology Co., LTD
 201, Building 011, Shangyan Second Industrial Zone,
 Address : Shangcun Community, Gongming Street, Guangming
 District, Shenzhen
 Product Name : LED tape lights
 Trade Name : /
 Model(s) : 5050, 5050RGB, 2835, 3528
 Ratings : Refer to the test report

Test Standards:

EN IEC 55015:2019+A11:2020; EN IEC 61547:2023

The above product has been tested by us with the listed standards and found in compliance with the European Electromagnetic Compatibility Directive 2014/30/EU. It is possible to use CE marking to demonstrate the compliance with this EMC Directive.

EN IEC 55015:2019+A11:2020: Limits and methods of measurement of radio disturbance characteristics of electrical lighting and similar equipment
EN IEC 61547:2023: Equipment for general lighting purposes - EMC immunity requirements

The referred test report(s) show that the product complies with standard(s) recognized as giving presumption of compliance with the essential requirements in the above mentioned EU Directive. Other relevant Directives have to be observed.

After preparation of the necessary technical documentation as well as the conformity declaration, the CE marking as shown below can be affixed on the equipment.



The statement is based on a single evaluation of the sample of above mentioned product(s). It does not imply an assessment of the whole production.

Waltek Testing Group (Shenzhen) Co., Ltd.

Tel: +86-755-33663308

Fax: +86-755-33663309

<http://www.waltek.com.cn>

E-mail: sem@waltek.com.cn



Reference No..... : WTX24X07163348C

Applicant..... : Shenzhen Yicaiju Photoelectric Technology Co., LTD

Address..... : 201, Building 011, Shangyan Second Industrial Zone, Shangcun Community, Gongming Street, Guangming District, Shenzhen

Manufacturer..... : Shenzhen Yicaiju Photoelectric Technology Co., LTD

Address..... : 201, Building 011, Shangyan Second Industrial Zone, Shangcun Community, Gongming Street, Guangming District, Shenzhen

Sample Name..... : LED tape lights

Model No. : 5050

Reference Model No. : 5050RGB,2835,3528

Brand..... : NA

Tested Standards:

IEC62321-3-1:2013, IEC 62321-4:2013+AMD1:2017 CSV , IEC62321-5:2013, IEC62321-7-1:2015, IEC62321-7-2:2017, IEC62321-6:2015, IEC62321-8:2017

The above product has been tested by us with the listed standards and found in compliance with the RoHS Directive 2011/65/EU and its amendment (EU) No 2015/863. It is possible to use CE marking to demonstrate the compliance with the regulations.

Electrotechnical products- determination of levels of ten regulated substances (lead ,mercury , cadmium , hexavalent chromium , polybrominated biphenyls , polybrominateddiphenyl ethers, bis(2-ethylhexyl) -phthalate (DEHP) , dibutyl phthalate (DBP) , benzylbutylphthalate (BBP), diisobutyl phthalate (DIBP)).

The referred test report (s) show that the product complies with standard(s) recognized as giving presumption of compliance with the essential requirements in the above mentioned EU Directive. Other relevant Directives have to be observed.

After preparation of the necessary technical documentation according the requirement of EN IEC 63000:2018 as well as the verification of conformity the CE marking as shown below can be affixed on the equipment.



Jandy So/GM
Date of Issue: 2024-07-17

This Verification of Conformity confirms the compliance with the listed requirements on a Voluntary basis. It refers only to the sample submitted and does not imply an assessment of the whole production and does not permit the use of the test lab logo.

Waltek Testing Group (Shenzhen) Co., Ltd.
 Tel:+86-755-33663308 Fax:+86-755-33663309
 Http://www.waltek.com.cn E-mail:sem@waltek.com.cn

Reference No. : WTN24N06132846E
Applicant : Guangdong Zhangong Electric Technology Co., Ltd.
Address : 701, Building 29, Zhifu Garden, Xingtan Town, Shunde District, Foshan City
Manufacturer : Same as applicant
Address : Same as applicant
Product : Furniture socket
Model No. : ZG-PDU J00/10A/16A, others see attachment
Technical data : 250 Vac, 50 Hz, other details see attachment



Test Standards:

EN 55032:2015+A11:2020
EN 55035:2017+A11:2020
EN IEC 61000-3-2:2019+A1:2021
EN 61000-3-3:2013+A1:2019+A2:2021

The above product has been tested by us with the listed standards and found in compliance with the European Electromagnetic Compatibility Directive 2014/30/EU. It is possible to use CE marking to demonstrate the compliance with this EMC Directive.

EN 55032: Electromagnetic compatibility of multimedia equipment - Emission Requirements
EN 55035: Electromagnetic compatibility of multimedia equipment - Immunity requirements
EN IEC 61000-3-2: Electromagnetic compatibility (EMC) - Part 3-2: Limits - Limits for harmonic current emissions (equipment input current ≤ 16 A per phase)
EN 61000-3-3: Electromagnetic compatibility (EMC) -Part 3-3: Limits -Limitation of voltage changes, voltage fluctuations and flicker in public low-voltage supply systems, for equipment with rated current ≤ 16 A per phase and not subject to conditional connection

The referred test report(s) show that the product complies with standard(s) recognized as giving presumption of compliance with the essential requirements in the above mentioned EU Directive. Other relevant Directives have to be observed.

After preparation of the necessary technical documentation as well as the EU Declaration of Conformity, the CE marking as shown below can be affixed on the equipment under the sole responsibility of the manufacturer.



Signature: Jianzhong Mao
(05) Date: 2024-07-15

The statement is based on a single evaluation of the sample of above mentioned product. It does not imply an assessment of the whole production.

Waltek Testing Group (Ningbo) Co., Ltd.

Hotline: 400-840-2288 E-mail: nb@waltek.com.cn
Http://www.waltek.com.cn

Attachment

Model list



Reference No: WTN24N06132846E

No.	Model	Rated Input	Rated Output	Note
1.	ZG-PDU J00/10A/16A	250 Vac, 50 - 60 Hz	USB max output: 5 Vdc, 2.1 A Socket: max 16 A	
2.	G-PDUM0/12A/15A			
3.	ZG-PDUG1/10A/16A			
4.	ZG-PDUG			
5.	ZG-PDU00			
6.	ZG-PDU00/10A/16A			
7.	ZG-PDUF/10A/16A			
8.	ZG-PDUW1/10A/16A			
9.	ZG-PDUW2/10A/16A			
10.	ZG-PDU			
11.	ZG-PDUC3/10A/15A			
12.	ZG-PDUC9/10A/15A			
13.	ZG-PDUA/10A/15A			
14.	ZG-PDUY/10A/15A			
15.	ZG-JJ/12A/15A			
16.	ZG-HG/12A/15A			
17.	ZG-ZJ/12A/15A			
18.	ZG-SJ/12A/15A			
19.	ZG-DQ/12A/15A			
20.	ZG-PC/12A/15A			



Registration No. : WTN22D07148186R3
Reference No. : WTN22D07148186R3Z
Applicant : Guangdong Zhangong Electric Technology Co., Ltd.
Address : Room 701, Building 29, Shunde Zhifu Park, No.8, 2nd Ring Road, Gaozan village committee, Xingtan town, Shunde District, Foshan City, Guangdong Province
Manufacturer : The same as above
Address : The same as above
Product : See attachment
Model No. : See attachment
Technical data : See attachment



Test Standards:

DIN VDE 0620-1(VDE 0620-1):2021-02
DIN VDE 0620-2-1 VDE 0620-2-1:2021-02/A1 VDE 0620-2-1/A1:2023-09
EN IEC 61558-1:2019
EN 61558-2-16:2009+A1:2013

The above product has been tested by us with the listed standards and found in compliance with the European Directive LVD 2014/35/EU. It is possible to use CE marking to demonstrate the compliance with this LVD Directive.

Plugs and socket-outlets for household and similar purposes Part 1: General requirements
**Plugs and socket-outlets for household and similar purposes –
Part 2-1: General requirements on plugs and portable socket-outlets**

The referred test report(s) show that the product complies with standard(s) recognized as giving presumption of compliance with the essential requirements in the above mentioned EU Directive. Other relevant Directives have to be observed.

After preparation of the necessary technical documentation as well as the EU Declaration of Conformity, the CE marking as shown below can be affixed on the equipment under the sole responsibility of the manufacturer.



Manager: Deval Qin
Date: 2025-04-18

The statement is based on a single evaluation of the sample of above mentioned product. It does not imply an assessment of the whole production.

Waltek Testing Group Co., Ltd.

Hotline: 400-840-2288

E-mail: info@waltek.com.cn

Http://www.waltek.com.cn

Ver.03. 26.09.2024, WALTEK is registered trademark. Utilisation and application requires prior approval.

Attachment

Model list



Reference No.: WTN22D07148186R3Z

Product name	Model Name	Description
Power Strip	ZG-PDUM0/12A/15A	250V~ 50/60Hz 16A USB Output: DC 5V 2.1A All models are exactly the same except the different appearance and model names
	ZG-PDUG1/10A/16A	
	ZG-PDUG	
	ZG-PDU00	
	ZG-PDU00/10A/16A	
	ZG-PDUJ00/10A/16A	
	ZG-PDUF/10A/16A	
	ZG-PDUW1/10A/16A	
	ZG-PDUW2/10A/16A	
	ZG-PDU	
	ZG-PDUC3/10A/15A	
	ZG-PDUC9/10A/15A	
	ZG-PDUA/10A/15A	
	ZG-PDUY/10A/15A	
	ZG-JJ/12A/15A	
	ZG-HG/12A/15A	
	ZG-ZJ/12A/15A	
ZG-SJ/12A/15A		
ZG-DQ/12A/15A		
ZG-PC/12A/15A		

====End of Attachment====

Waltek Testing Group Co., Ltd.

Hotline:400-840-2288

E-mail:info@waltek.com.cn

Http://www.waltek.com.cn

Ver.03. 26.09.2024, WALTEK is registered trademark. Utilisation and application requires prior approval.



Certificate of Compliance

Certificate Number: BOKE-251211102C01C

Certificate's Holder : Guangdong Zhongong Electric Technology Co., LTD
 Zertifikatsinhaber 701, Building 29, zhifuyuan Industrial Zone, Xingtan town, Shunde District, Foshan City, Guangdong Province

Manufacturer : Guangdong Zhongong Electric Technology Co., LTD
 Hersteller 701, Building 29, zhifuyuan Industrial Zone, Xingtan town, Shunde District, Foshan City, Guangdong Province

Trade Mark : /
 Warenzeichen

Product : Furniture socket
 Produkt

Model(s) : ZG-JJO-B2A-2A
 Bezeichnung ZG-JJO-B2B-2A, ZG-PDU J00, ZG-PDU JCO/10A/16A, ZG-JJY-1UK to -8UK, ZG-JJM/32A/15A, ZG-JJM, LH-D, ZG-JJM-A2, ZG-JJM1-A2

Test Standard : IEC 62321-3-1:2015, IEC 62321-4-2013+A1:2017, IEC 62321-5:2013,
 Geprüft nach IEC 62321-6:2015, IEC 62321-7-1:2015, IEC 62321-7-2:2017, IEC 62321-8:2017

Test Report No. : BOKE-251211102C01
 Bericht Nr

广东省詹工电气科技有限公司
 真实的发票才有效

文件
 日期: 2020/12/17

The EUT described above has been consolidated by us and found in compliance with the council RoHS Directive 2011/65/EU Annex II amending Annex (EU)2015/863. The essential requirements are fulfilled accordingly based on the technical specifications applicable at the time of issuance. It is only valid in connection with the test report.

After preparation of the necessary technical documentation according to the Requirement of EN IEC 63000:2018 as well as the verification of conformity the CE marking as shown below can Be affixed on the equipment.

