

# N657P418044

# N657P418045

Productmanual  
 Gebrauchsanweisung  
 Manuel du produit  
 Manual del producto  
 Manuale del prodotto

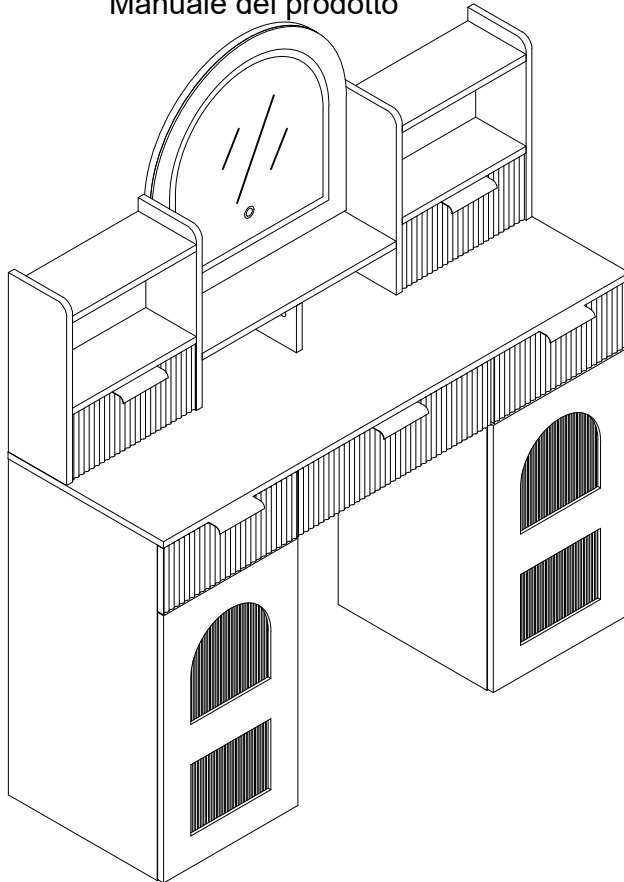

Importeur	Decobus Handel GmbH
Adresse	Innungsstraße 9, 21244 Buchholz, Deutschland
URL	<a href="https://www.decobusgroup.de">https://www.decobusgroup.de</a>
Hersteller	Qingdao Rui Kesen Home Furnishing Co.,Ltd
Adresse	Room 517, Building 32, No. 89, Changcheng Road, Chengyang District, Qingdao City, Shandong province, China
Email/URL	Frank_hfmy@163.com
EC REP	Decobus Handel GmbH Innungsstraße 9, 21244 Buchholz, Deutschland <a href="https://www.decobusgroup.de">https://www.decobusgroup.de</a>



**FR**  
 Cet appareil, ses câbles, et batterie se recyclent

À DÉPOSER EN MAGASIN

À DÉPOSER EN DÉCHÈTERIE

OU

Points de collecte sur [www.quefairedemesdechets.fr](http://www.quefairedemesdechets.fr)  
 Privilégiez la réparation ou le don de votre appareil !

 2PERS	 60 MIN	Tool Required Not Provided	



[DE]

Warnung: Lesen Sie die Anleitung vor dem Zusammenbau bitte vollständig durch. Überprüfen Sie, ob Sie alle auf den Seiten aufgeführten Komponenten und Werkzeuge haben.

Warnung: Legen Sie alle Teile auf eine ebene Fläche. Legen Sie eine weiche Decke oder Ähnliches darunter, um sie vor Kratzern oder Flecken zu schützen. Vermeiden Sie es, Komponenten über den Boden zu ziehen oder zu schieben.

Warnung: Überprüfen Sie regelmäßig alle Beschläge und Befestigungen, um sicherzustellen, dass sie sicher sind und um Unfälle zu vermeiden. Wenn Teile fehlen, kaputt, beschädigt oder abgenutzt sind, verwenden Sie das Produkt nicht weiter, bis es mit vom Hersteller autorisierten Teilen repariert wurde.

Warnung: Lassen Sie Kinder nicht auf die Möbel klettern, da dies zum Umkippen und zu schweren Verletzungen führen kann. Bauen Sie die Möbel außerhalb der Reichweite von Kindern zusammen.

Warnung: Stellen Sie die Möbel nicht in die Nähe von Feuerquellen oder heißen Gegenständen, um Brandgefahr zu vermeiden.

Warnung: Reinigen Sie die Möbel mit einem feuchten Tuch oder Alkohol. Verwenden Sie keine Reinigungsmittel mit ätzenden Chemikalien.

Warnung: Dieses Produkt ist mit einer Kippschutzvorrichtung ausgestattet. Bitte installieren Sie diese Vorrichtung unbedingt, um unnötige Verletzungen durch Umkippen zu vermeiden.

[EN]

Warning: Please read instructions fully before starting assembly. Check you have all the components and tools listed on pages.

Warning: Please place all parts on a flat surface. Place a soft blanket or similar underneath to protect against scratches or stains. Avoid dragging or sliding components across the floor.

Warning: Regularly check all fittings and fastenings to ensure they are secure and to prevent accidents. If any parts are missing, broken, damaged, or worn, discontinue use of the product until repairs have been made using factory authorized parts.

Warning: Do not allow children to climb on the furniture as this may result in tipping and serious personal injury. Assemble the furniture away from the reach of children.

Warning: Do not place furniture close to fire sources or high-temperature objects to avoid the risk of fire.

Warning: Clean furniture with a damp cloth or alcohol, avoid using cleaning agents containing corrosive chemicals.

Warning: This product is equipped with an anti-tilt device. Please be sure to install this device to prevent unnecessary injuries caused by tipping.

[FR]

Avertissement : Veuillez lire entièrement les instructions avant de commencer l'assemblage. Vérifiez que vous disposez de tous les composants et outils répertoriés sur les pages.

Avertissement : Veuillez placer toutes les pièces sur une surface plane. Placez une couverture douce ou similaire en dessous pour les protéger des rayures ou des taches. Évitez de faire glisser les composants sur le sol.

Avertissement : Vérifiez régulièrement tous les raccords et fixations pour vous assurer qu'ils sont bien fixés et pour éviter les accidents. Si des pièces manquent, sont cassées, endommagées ou usées, cessez d'utiliser le produit jusqu'à ce que des réparations aient été effectuées à l'aide de pièces autorisées par l'usine.

Avertissement : Ne laissez pas les enfants grimper sur les meubles car cela pourrait entraîner un basculement et des blessures graves. Assemblez les meubles hors de portée des enfants.

Avertissement : Ne placez pas les meubles à proximité de sources de feu ou d'objets à haute température pour éviter tout risque d'incendie.



Avertissement : Nettoyez les meubles avec un chiffon humide ou de l'alcool, évitez d'utiliser des produits de nettoyage contenant des produits chimiques corrosifs.

Avertissement : Ce produit est équipé d'un dispositif anti-basculement. Assurez-vous d'installer ce dispositif pour éviter les blessures inutiles causées par un basculement.

[IT]

Attenzione: leggere attentamente le istruzioni prima di iniziare il montaggio. Verificare di avere tutti i componenti e gli strumenti elencati nelle pagine.

Attenzione: posizionare tutte le parti su una superficie piana. Posizionare una coperta morbida o simile sotto per proteggere da graffi o macchie. Evitare di trascinare o far scivolare i componenti sul pavimento.

Attenzione: controllare regolarmente tutti i raccordi e i dispositivi di fissaggio per assicurarsi che siano sicuri e per prevenire incidenti. Se alcune parti sono mancanti, rotte, danneggiate o usurate, interrompere l'uso del prodotto fino a quando non siano state eseguite le riparazioni utilizzando parti autorizzate dalla fabbrica.

Attenzione: non consentire ai bambini di arrampicarsi sui mobili poiché ciò potrebbe causare ribaltamenti e gravi lesioni personali. Montare i mobili lontano dalla portata dei bambini.

Attenzione: non posizionare i mobili vicino a fonti di fuoco o oggetti ad alta temperatura per evitare il rischio di incendio.

Attenzione: pulire i mobili con un panno umido o alcol, evitare di utilizzare detergenti contenenti sostanze chimiche corrosive.

Attenzione: questo prodotto è dotato di un dispositivo antiribaltamento. Assicurarsi di installare questo dispositivo per prevenire lesioni inutili causate dal ribaltamento.

[ES]

Advertencia: Lea las instrucciones completamente antes de comenzar el montaje. Compruebe que tiene todos los componentes y herramientas que se enumeran en las páginas.

Advertencia: Coloque todas las piezas sobre una superficie plana. Coloque una manta suave o algo similar debajo para protegerlas de rayones o manchas. Evite arrastrar o deslizar los componentes por el piso.

Advertencia: Verifique regularmente todos los accesorios y fijaciones para asegurarse de que estén seguros y evitar accidentes. Si falta alguna pieza, está rota, dañada o desgastada, deje de usar el producto hasta que se hayan realizado las reparaciones con piezas autorizadas de fábrica.

Advertencia: No permita que los niños se suban a los muebles, ya que esto puede provocar que se vuelquen y lesiones personales graves. Monte los muebles fuera del alcance de los niños.

Advertencia: No coloque los muebles cerca de fuentes de fuego u objetos de alta temperatura para evitar el riesgo de incendio.

Advertencia: Limpie los muebles con un paño húmedo o alcohol, evite usar agentes de limpieza que contengan químicos corrosivos.

Advertencia: Este producto está equipado con un dispositivo antivuelco. Asegúrese de instalar este dispositivo para evitar lesiones innecesarias causadas por vuelcos.

Importeur	Decobus Handel GmbH
Adresse	Innungsstraße 9, 21244 Buchholz, Deutschland
URL	<a href="https://www.decobusgroup.de">https://www.decobusgroup.de</a>
Hersteller	Qingdao Rui Kesen Home Furnishing Co.,Ltd
Adresse	Room 517, Building 32, No. 89, Changcheng Road, Chengyang, District, Qingdao City, Shandong province, China
Email/URL	Frank_hfmy@163.com
EC REP	Decobus Handel GmbH Innungsstraße 9, 2124 Buchholz, Deutschland <a href="https://www.decobusgroup.de">https://www.decobusgroup.de</a>

**EN** It may be necessary to adjust the hinges so that the doors align. Use the instructions below as a guide.

**FR** Il est parfois nécessaire d'ajuster les charnières pour un meilleur alignement des portes. Servez-vous des instructions ci-dessous comme guide.

**ES** Puede que sea necesario ajustar los quicios de forma que se alineen las puertas. Use las instrucciones que aparecen debajo como guía.

**DE** Möglicherweise müssen Sie die Scharniere so einstellen, dass die Türen ausgerichtet sind. Verwenden Sie die nachstehenden Anweisungen als Leitfaden.

**IT** Potrebbe essere necessario regolare le cerniere in modo che le porte siano allineate. Per fare ciò attenersi alle istruzioni sottostanti.

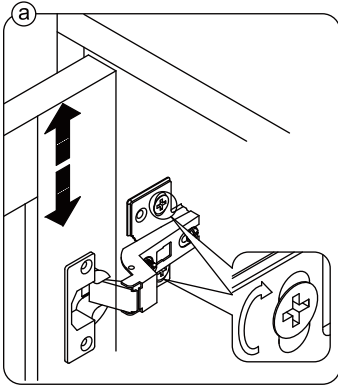

**EN** To adjust the door vertically loosen the screw as shown and move up and down as needed.

**FR** Si vous souhaitez régler la porte **verticalement**, desserrez la vis comme indiqué et déplacez la porte de haut en bas selon les besoins.

**ES** Para ajustar la puerta **verticalmente** afloje el tornillo tal y como se muestra y muévalo hacia arriba o hacia abajo según sea necesario.

**DE** Um die Tür **vertikal** auszurichten, lösen Sie die Schraube wie abgebildet und bewegen Sie sie nach Bedarf nach oben oder nach unten.

**IT** Per allineare la porta **verticalmente** allentare la vite come mostrato e spostarla in alto o in basso secondo necessità.

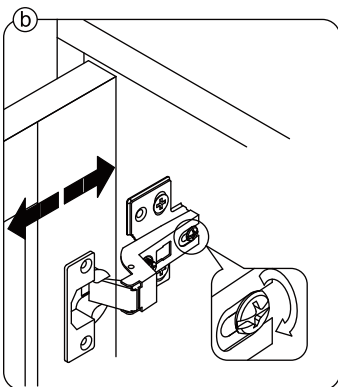

**EN** To adjust the gap from the door to the main frame turn the screw clockwise or anti-clockwise as needed.

**FR** Si vous souhaitez ajuster l'**écart** entre la porte et le cadre principal, tournez la vis dans le sens des aiguilles d'une montre ou dans le sens inverse, si nécessaire.

**ES** Para ajustar el **espacio** desde la puerta al marco principal, gire el tornillo en sentido horario o antihorario, según se necesite.

**DE** Um den **Abstand** von der Tür zum Hauptrahmen auszurichten, drehen Sie die Schraube je nach Bedarf im oder gegen den Uhrzeigersinn.

**IT** Per regolare lo **spazio** tra la porta e il telaio principale, avvitare o svitare la vite secondo necessità.

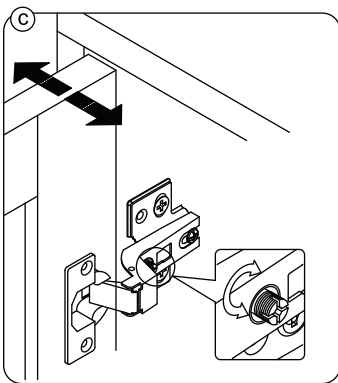

**EN** To adjust the door laterally adjust the screw as shown by turning clockwise or anti-clockwise.

**FR** Si vous souhaitez ajuster la porte **latéralement**, ajustez la vis comme indiqué en tournant dans le sens des aiguilles d'une montre ou dans le sens inverse des aiguilles d'une montre.

**ES** Para ajustar la puerta **lateralmente** ajuste el tornillo tal y como se muestra girándolo en sentido horario y antihorario.

**DE** Um die Tür **seitlich** auszurichten, stellen Sie bitte die Schraube wie abgebildet durch Drehen im oder gegen den Uhrzeigersinn ein.

**IT** Per allineare la porta **lateralmente** regolare la vite come mostrato, avvitandola o svitandola.

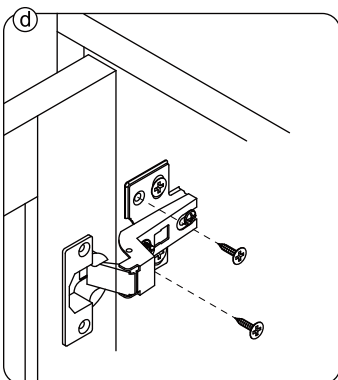

**EN** Please fix other screws

**FR** Merci de serrer les autres vis.

**ES** Fije los demás tornillos

**DE** Befestigen Sie bitte die anderen Schrauben

**IT** Fissare le altre viti

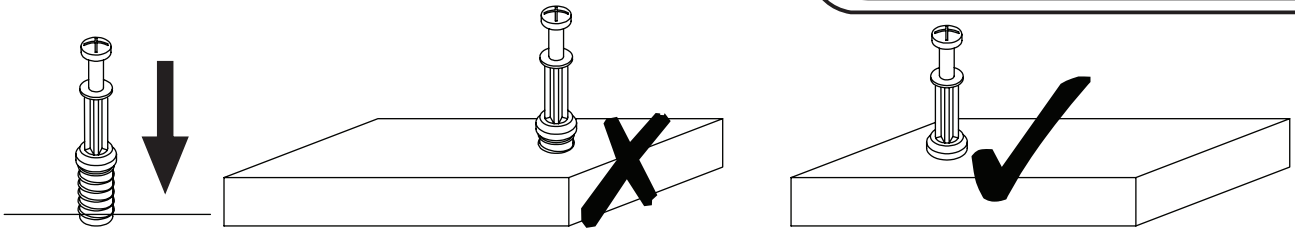

**EN\_QUICKFIT:** Tighten quickfit until shoulder is flush with panel. Do not overtighten or undertighten.

**FR\_RACCORD RAPIDE:** Faites serrer le raccord rapide jusqu'à ce que l'épaulement soit parfaitement encastré dans le panneau. Il ne faut ni trop serrer ni insuffisamment serrer.

**ES\_QUICKFIT:** Apriete quickfit hasta que el hombro se descargue con el panel. NO lo sobreapriete ni lo apriete poco.

**DE\_QUICKFIT:** Ziehen Sie den Quickfit fest, bis die Schulter mit der Platte bündig ist. Bitte nicht zu fest oder zu schwach anziehen.

**IT\_MONTAGGIO RAPIDO:** Stringere il montaggio rapido fino a quando la spalla è a filo con il pannello, non stringere troppo o troppo poco.

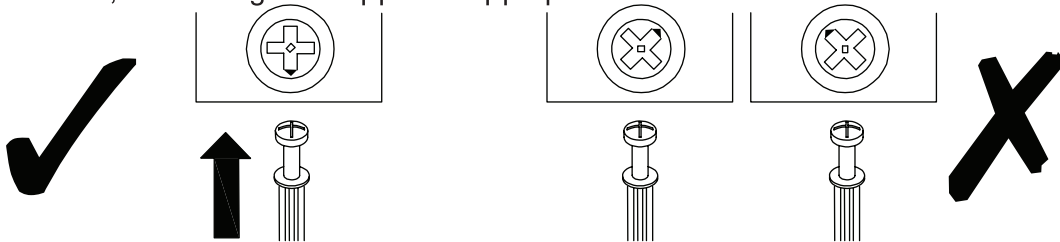

**EN\_CAM LOCK:** When fitting cam lock, ensure starting position is correct before you insert connecting quickfit.

**FR\_SERRURE BATTEUSE:** Avant d'insérer la serrure batteuse, veillez à la bonne orientation avant d'insérer le raccord rapide.

**ES\_CIERRE DE LA CÁMARA:** Cuando instale el cierre de la cámara, asegúrese de que la posición de inicio es correcta antes de que inserte el quickfit conector.

**DE\_CAM-LOCK:** Achten Sie bei der Montage des Cam-Locks auf die richtige Ausgangsposition, bevor Sie den Quickfit einsetzen.

**IT\_BLOCCAGGIO A CAMMA:** Quando si monta il bloccaggio a camma, assicurarsi che la posizione iniziale sia corretta prima di inserire il montaggio rapido di collegamento.

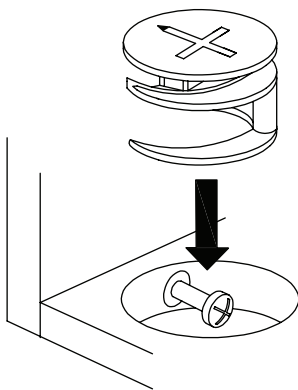

**EN\_Quickfit head** should be in the centre of the cam lock when the two panels are joined.

Cam lock should be inserted before quickfit.

**FR\_Lorsque** les deux panneaux sont assemblés, la tête du raccord rapide doit reposer au centre de la serrure batteuse. Il faut insérer la serrure batteuse avant le raccord rapide.

**ES\_El** cabezal del quickfit debe estar en el centro del cierre de la cámara cuando se unan los dos paneles.

Se debe insertar el cierre de la cámara antes que el quickfit.

**DE\_Der** Quickfit-Kopf sollte sich in der Mitte des Cam-Locks befinden, wenn die beiden Platten zusammengefügt sind. Der Cam-Lock sollte vor dem Quickfit eingesetzt werden.

**IT\_La** testa del montaggio rapido deve trovarsi al centro del bloccaggio a camma quando i due pannelli sono uniti.

Il Bloccaggio a Camma deve essere inserito prima del montaggio rapido.

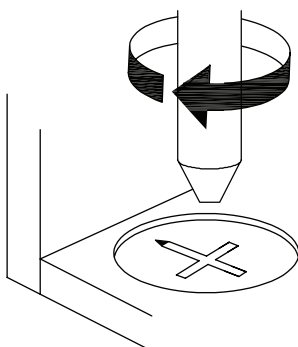

**EN\_Turn** cam lock clockwise to tighten.

**FR\_Faites** tourner la serrure batteuse dans le sens des aiguilles d'une montre pour la resserrer.

**ES\_Gire** el cierre de la cámara en sentido horario para apretarlo.

**DE\_Drehen** Sie den Cam-Lock im Uhrzeigersinn, um ihn festzuziehen.

**IT\_Ruotare** il bloccaggio a camma in senso orario per stringere.



**DE**

**Warnung:** Die maximale Belastbarkeit dieses Möbels beträgt:60kg, bitte nicht überlasten!

**EN**

**Warning:** The maximum load-bearing capacity of this furniture is:60kg, please do not overload!

**FR**

**Avertissement :** La capacité de charge maximale de ce meuble est de :60kg, merci de ne pas surcharger !

**IT**

**Attenzione:** la capacità di carico massima di questo mobile è:60kg, non sovraccaricare!





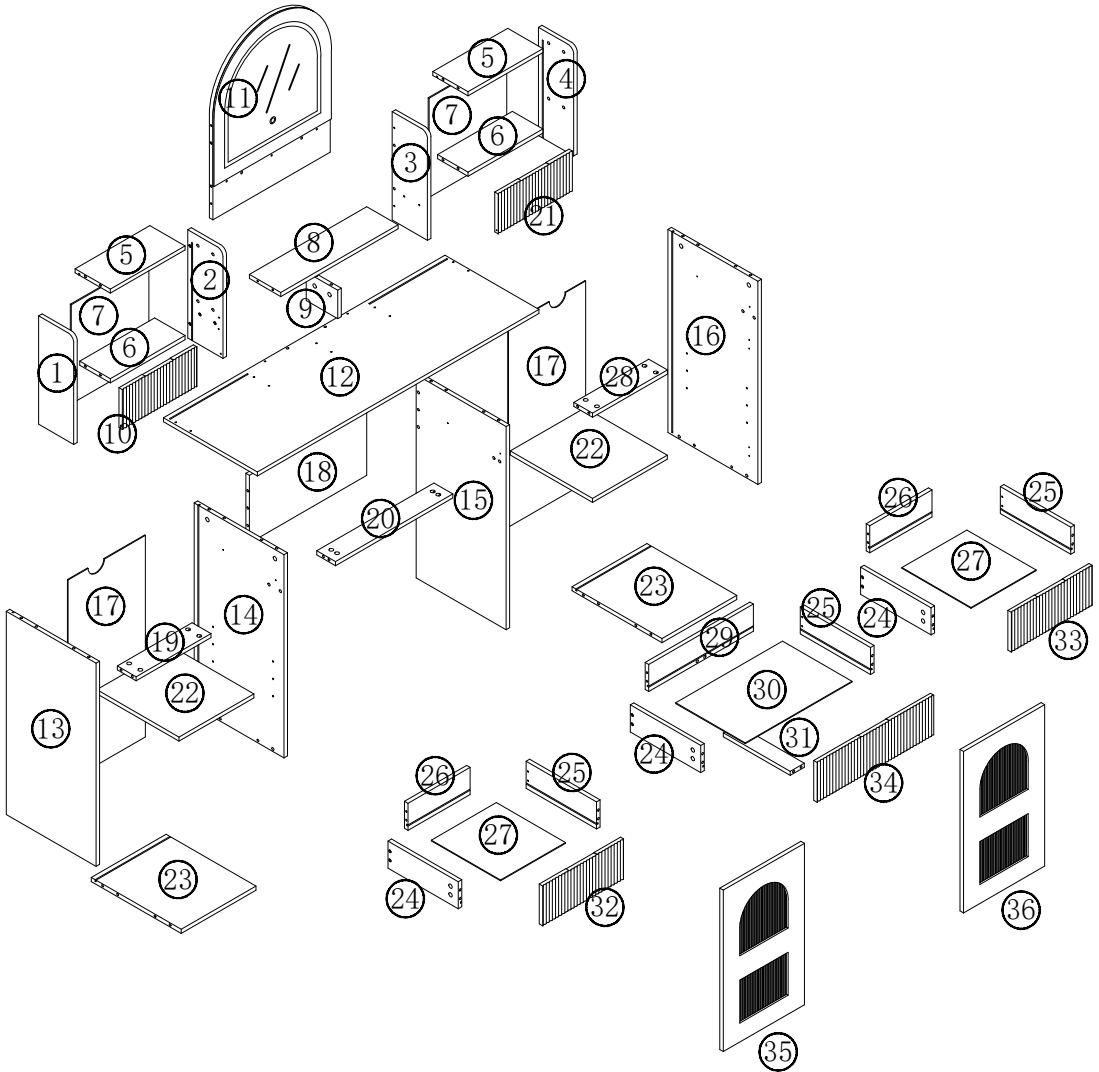

**ES**

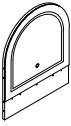

**Advertencia:** La capacidad máxima de carga de este mueble es:60kg, ¡no lo sobrecargue!

# Parts List

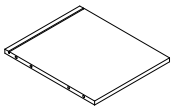

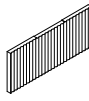



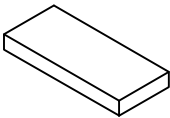





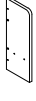

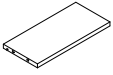

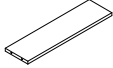
# N657P418044

11		1
13		1
14		1
15		1
16		1
23		2
32		1
33		1

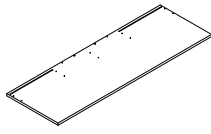

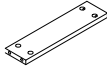
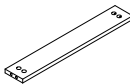

35		1
36		1
 Hardware kit		

# N657P418045





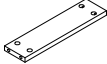
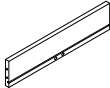
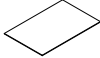

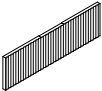





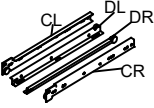

①		1
②		1
③		1
④		1
⑤		2
⑥		2
⑦		2
⑧		1
⑨		1

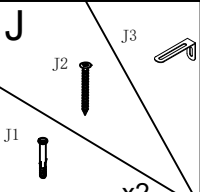

⑩		1
⑫		1
⑰		2
⑱		1
⑲		1
⑳		1
㉑		1
㉒		2
㉔		3

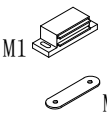
# N657P418045

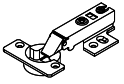

25		3
26		2
27		2
28		1
29		1
30		1
31		1
34		1

# Hardware N657P418044

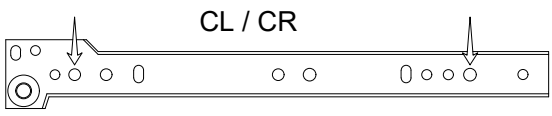
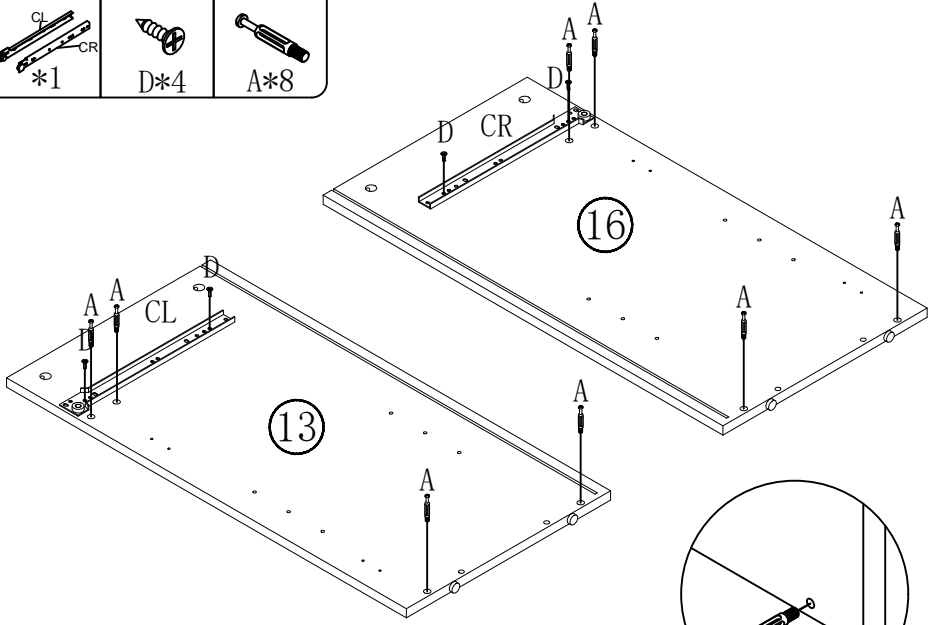

<b>A</b>  40mm x67	<b>B</b> $\varnothing 15 \times 11$  x67	<b>C</b> $\varnothing 8 \times 30$  x28	<b>D</b> $\varnothing 3.5 \times 14$  x92	<b>E</b> $\varnothing 5 \times 40$  x23
 x3	<b>F</b>  x5	<b>G</b>  x2	<b>H</b>  x20	<b>I</b>  x8
<b>J</b>  x2	<b>L</b>  x4	<b>M</b>  x2	<b>N</b> $4 \times 30$  x12	<b>O</b>  x4
<b>P</b>  x67				

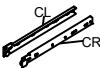
<b>1</b>	 CL CR *1	 D*4	 A*8
----------	--	---	---



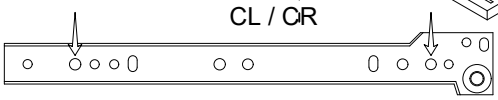
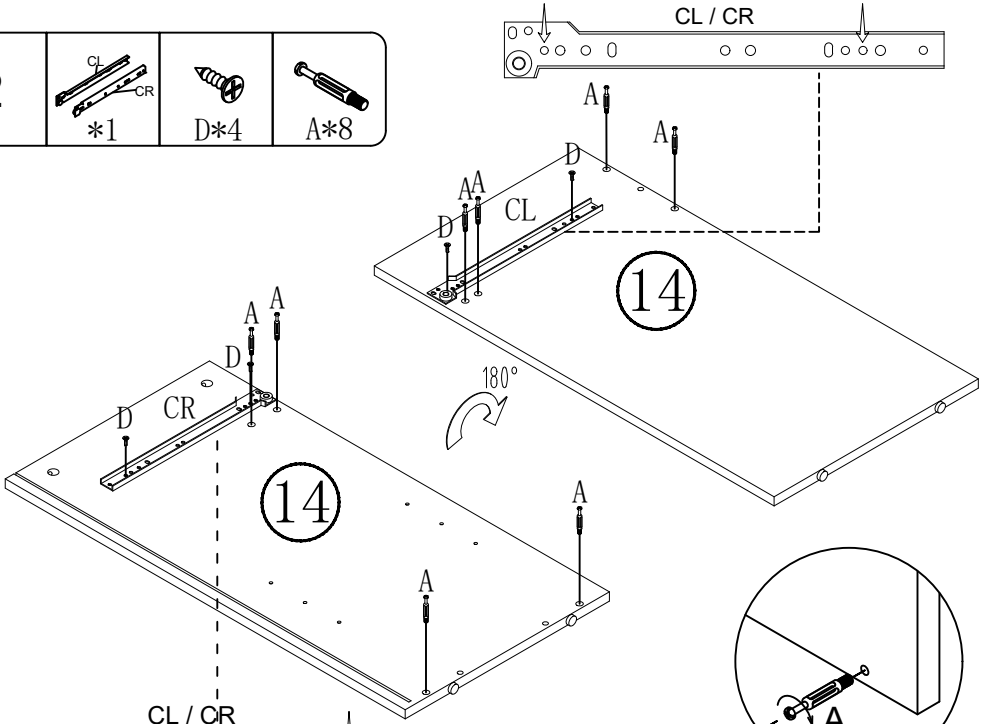

<b>2</b>	 CL CR *1	 D*4	 A*8
----------	---	--	--



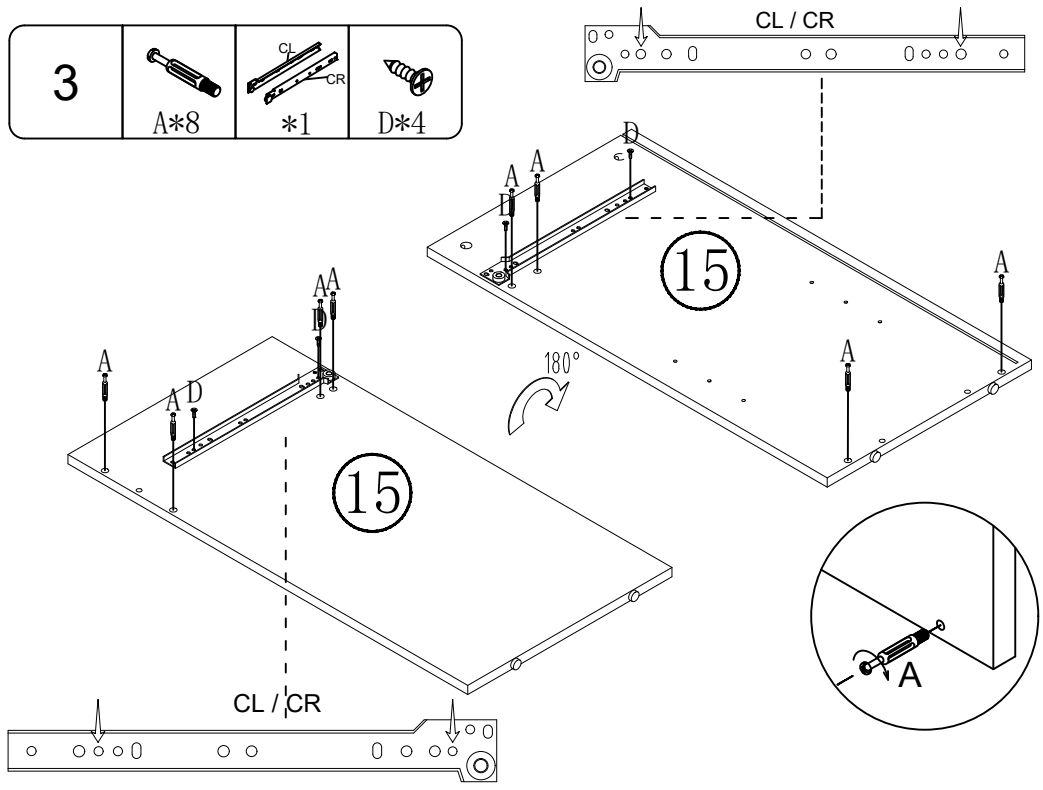

3	 A*8	 *1	 D*4
---	---	--	---



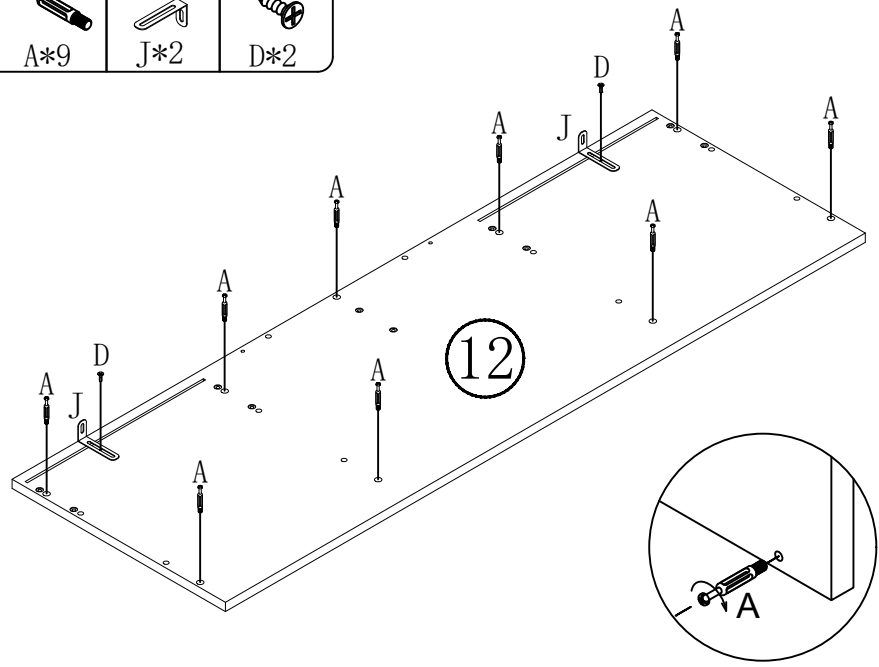

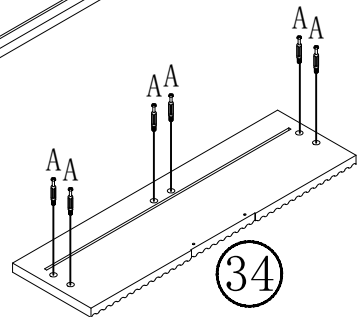
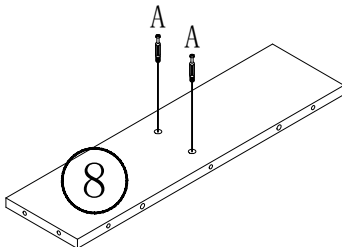
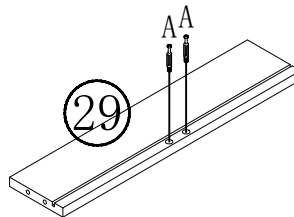
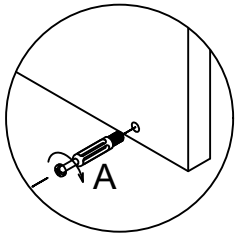
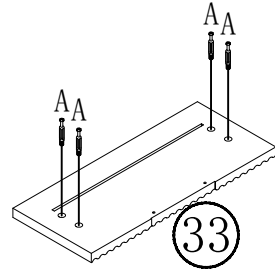
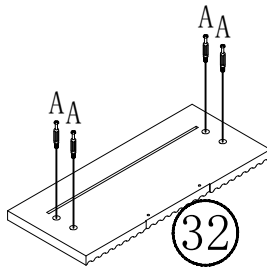
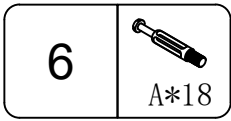
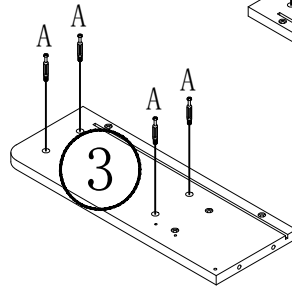
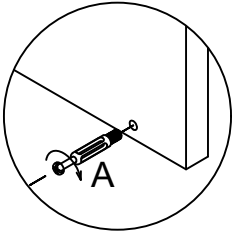
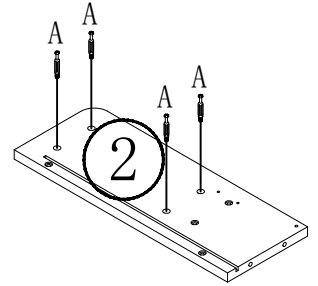
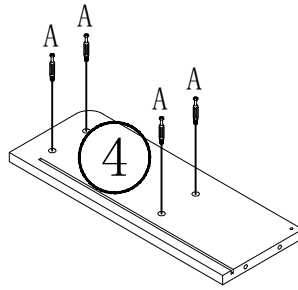
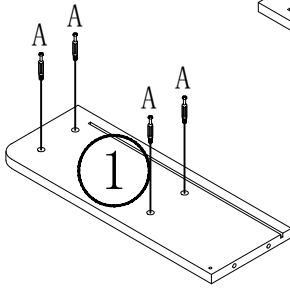
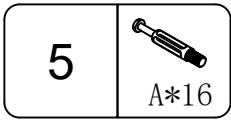
4	 A*9	 J*2	 D*2
---	--	--	--



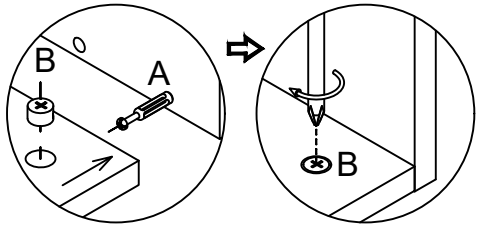
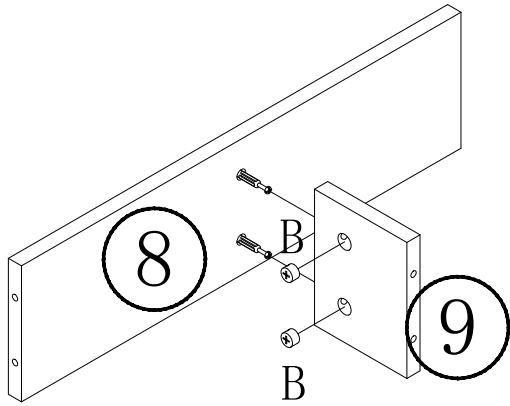

7	 B*2
---	---



8	 E*3	 C*2
---	--	--

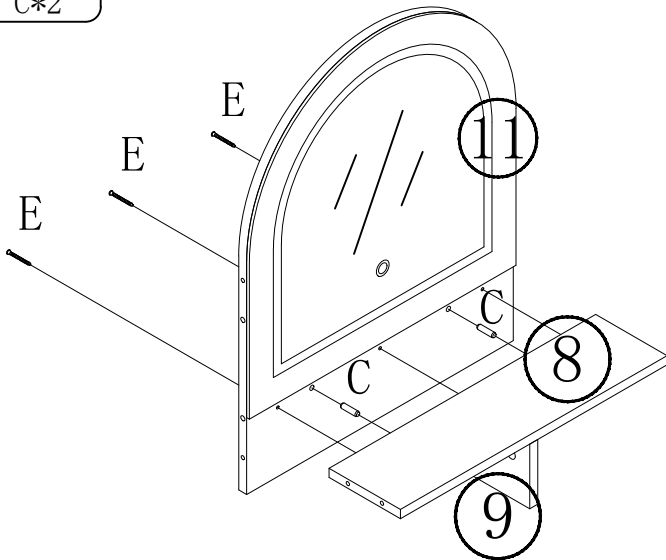

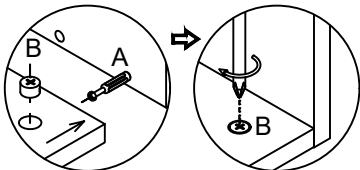
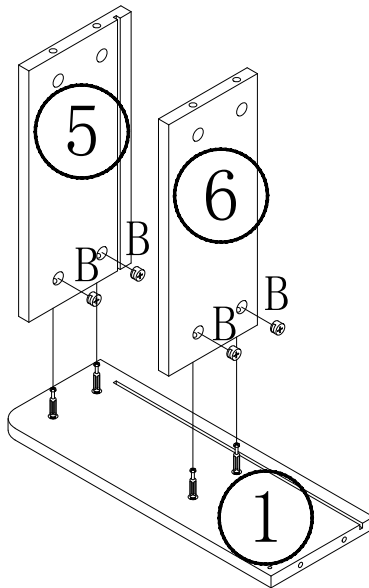
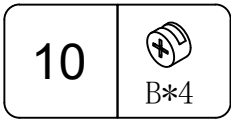
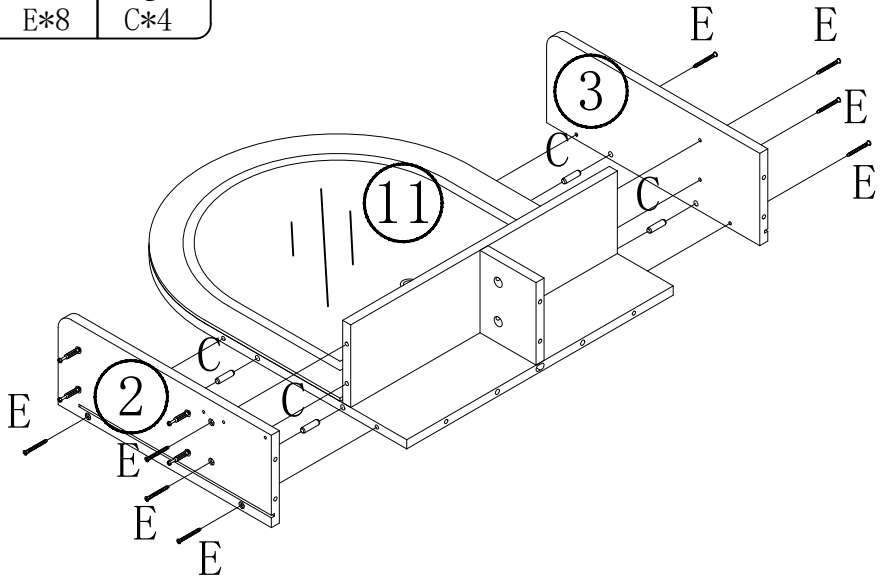
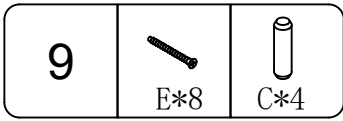

11



B\*4

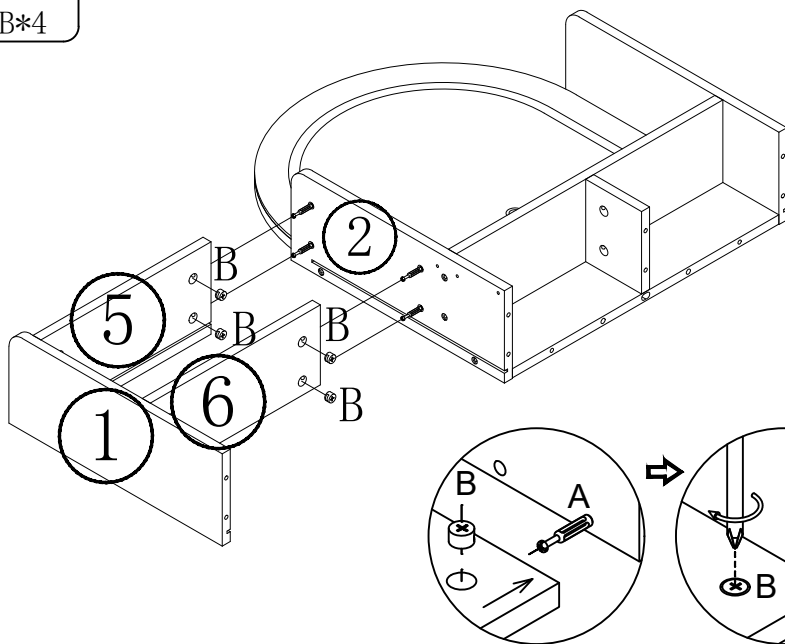

12



B\*4

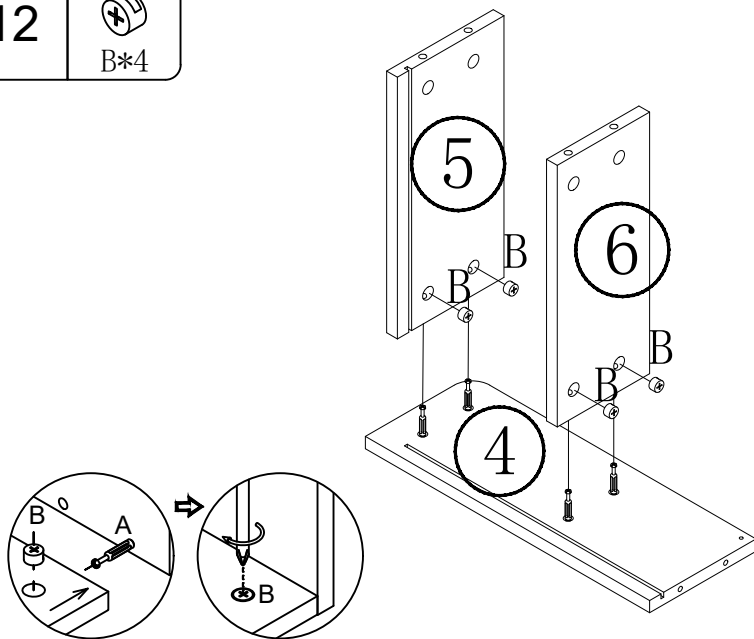

13



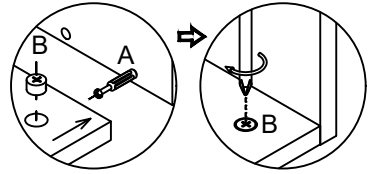
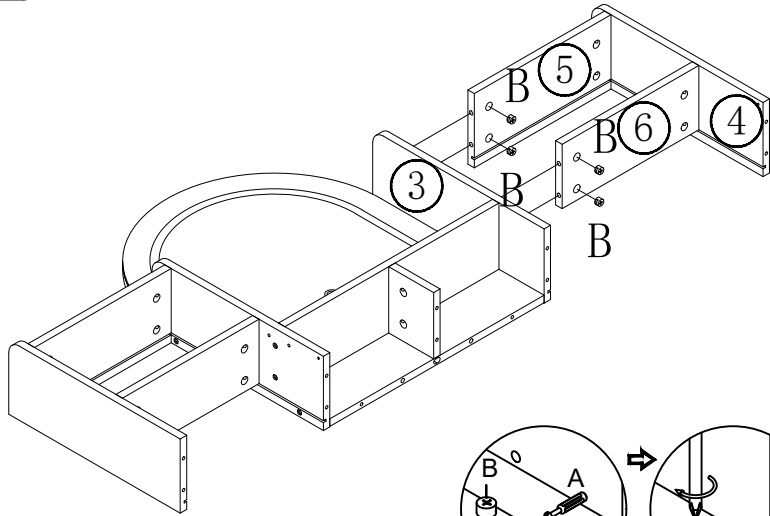

B\*4

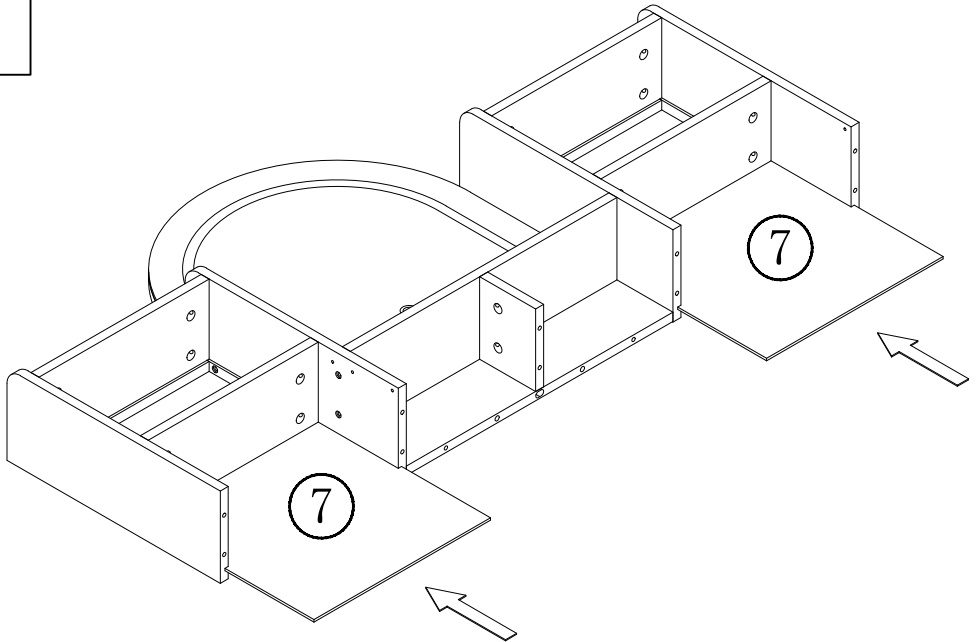

14



15	 E*12	 C*2
----	--	---

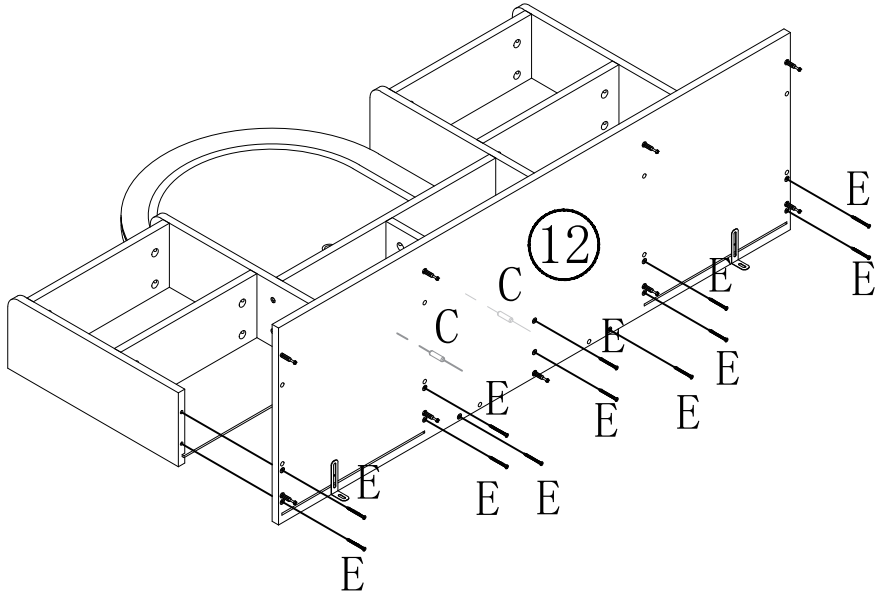

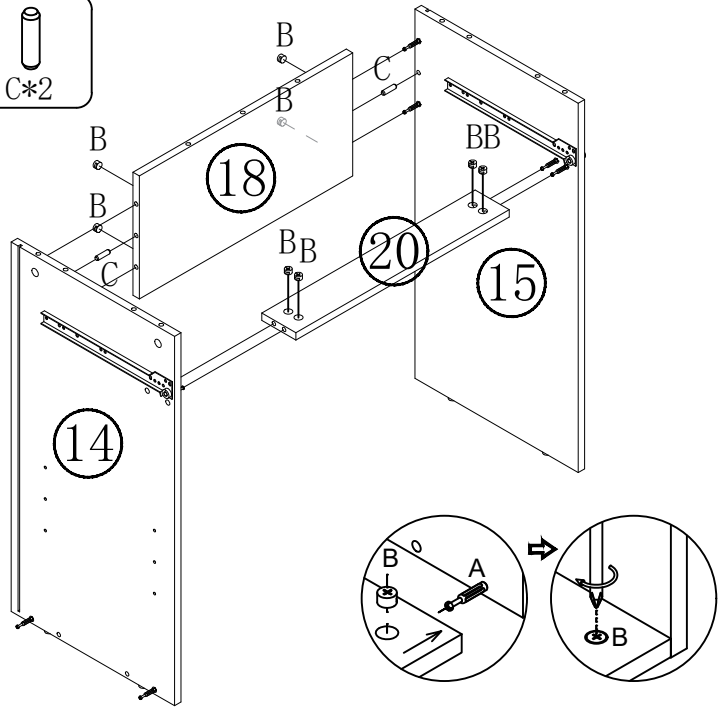

16	 B*8	 C*2
----	--	--



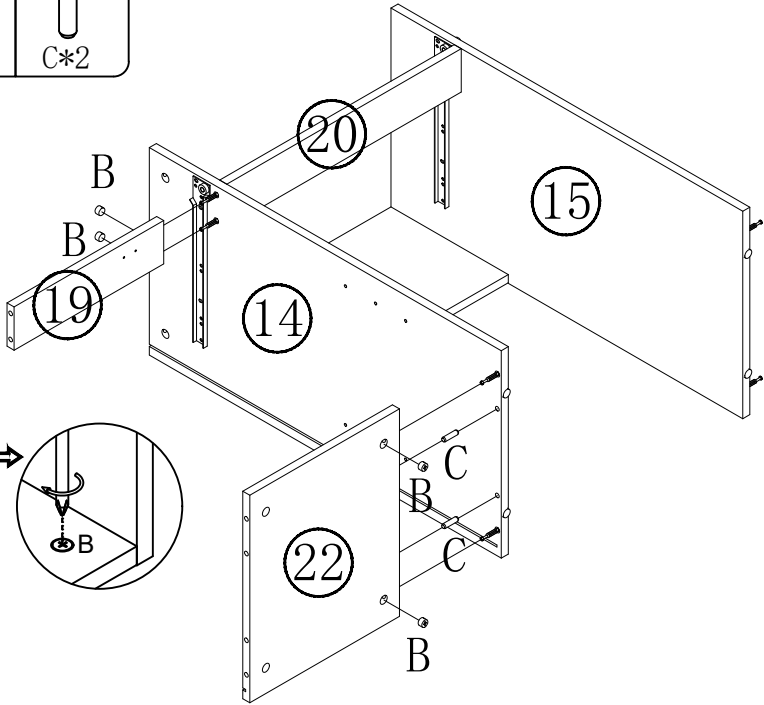

17	 B*4	 C*2
----	---	---



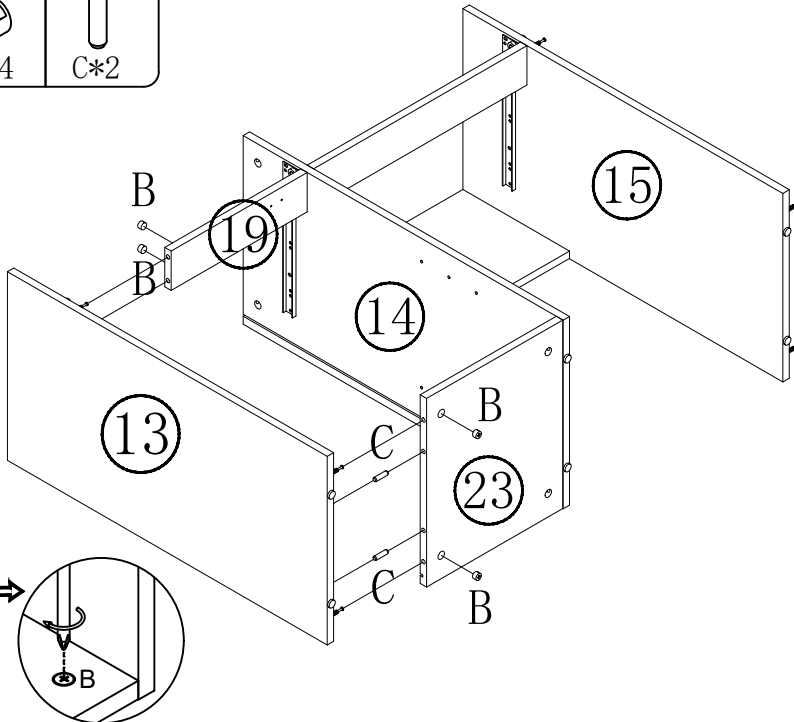

18	 B*4	 C*2
----	--	--



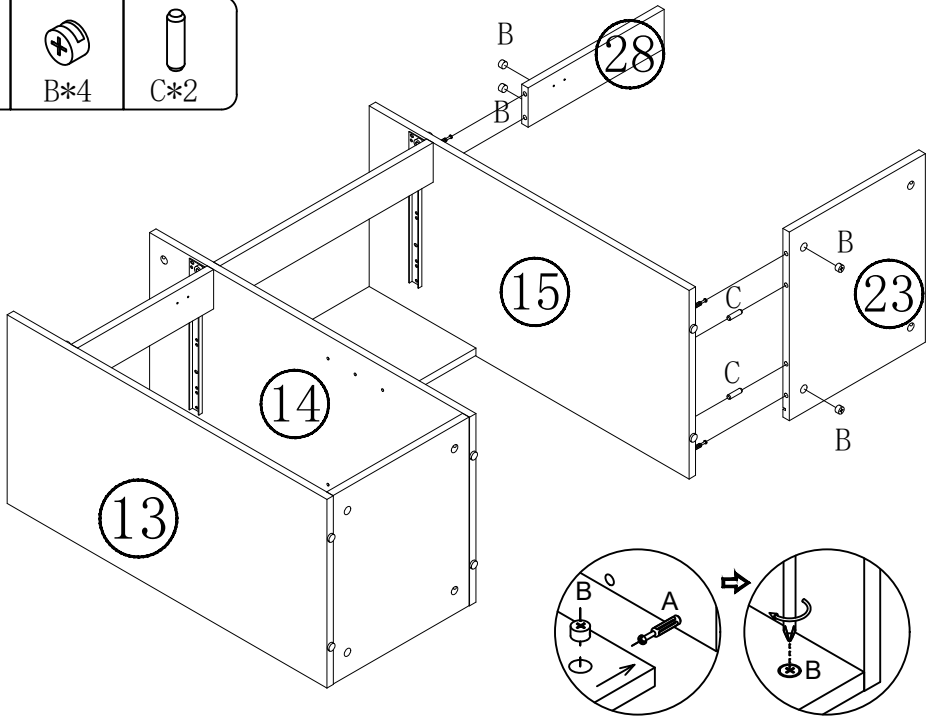

19	 B*4	 C*2
----	---	---

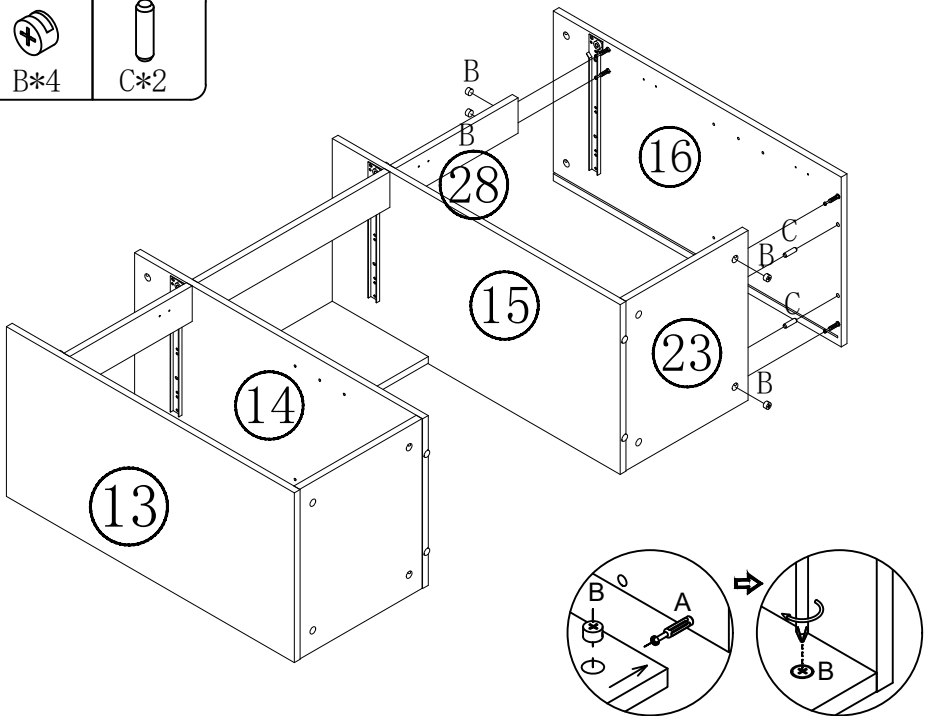

20	 B*4	 C*2
----	--	--



21	 G*2	 D*4
----	---	---

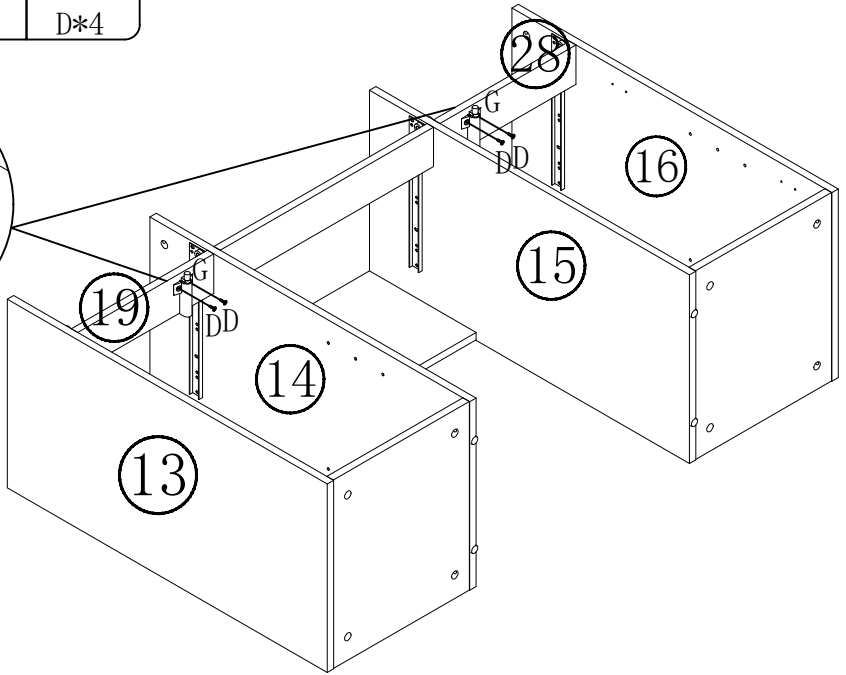
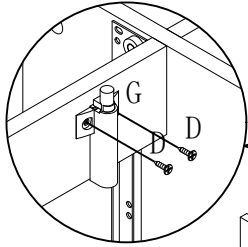

22

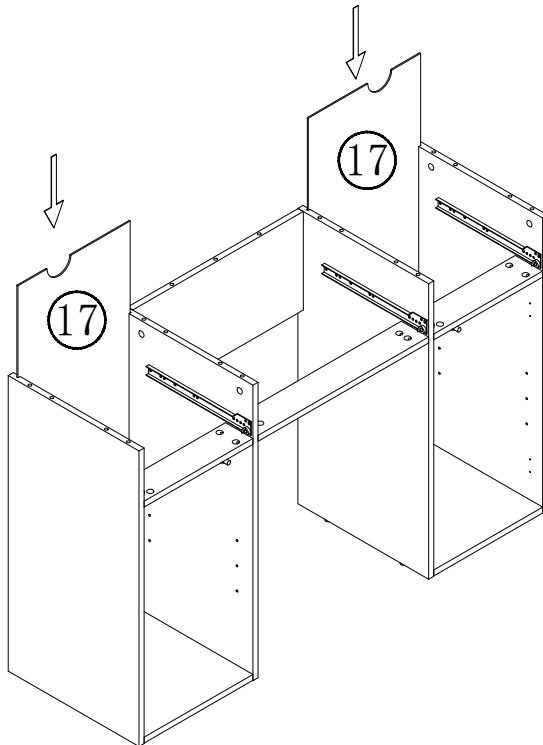

23



B\*9



C\*10

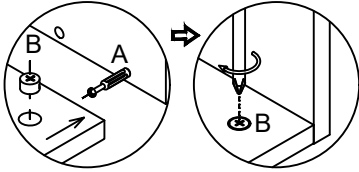
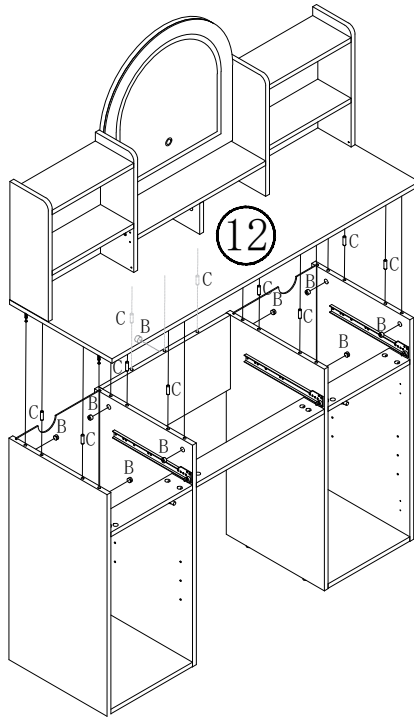

24



H\*20



D\*20

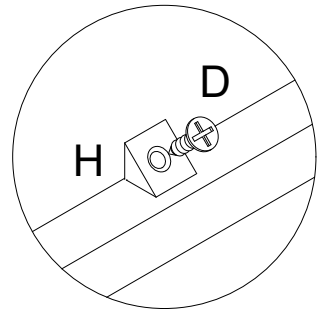
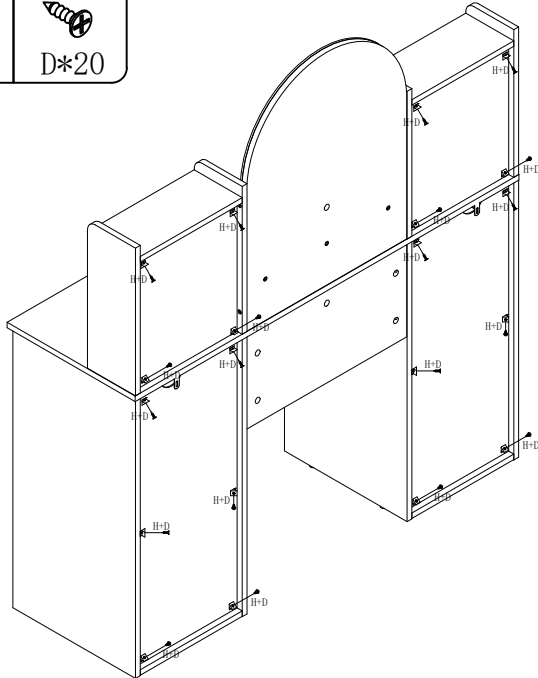

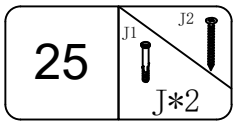



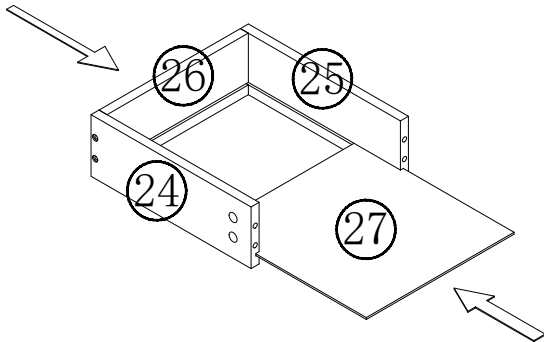
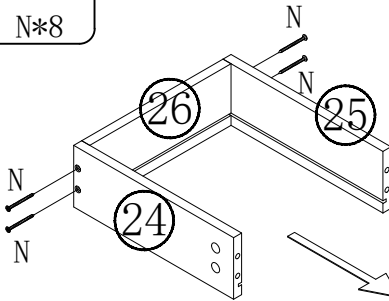
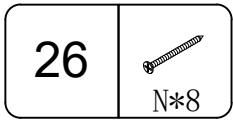
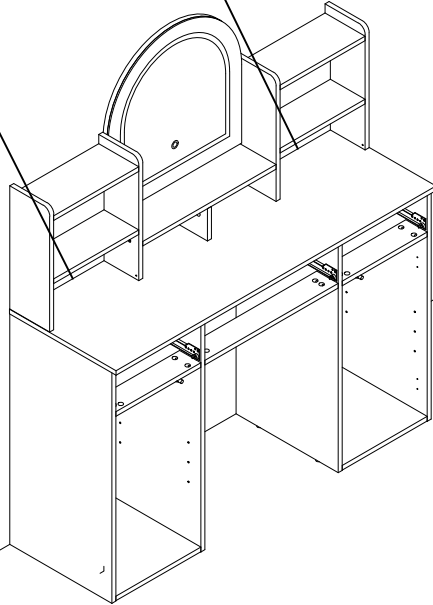
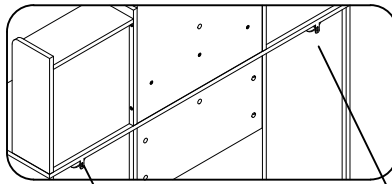
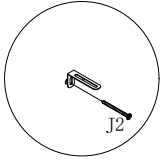
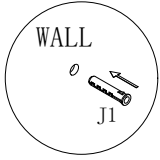

WALL



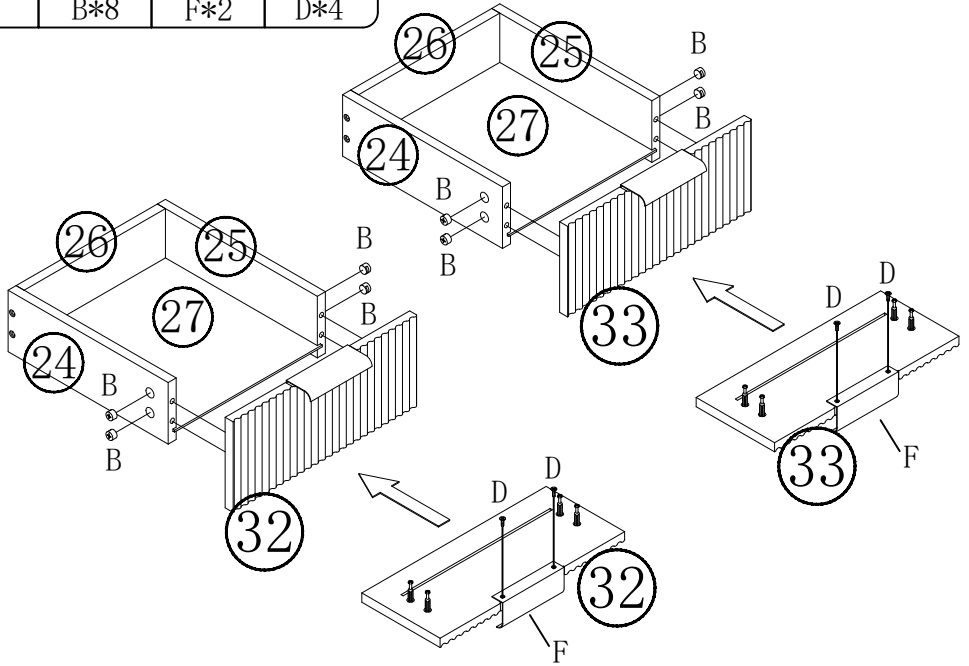

X2

27	 B*8	 F*2	 D*4
----	---	---	---



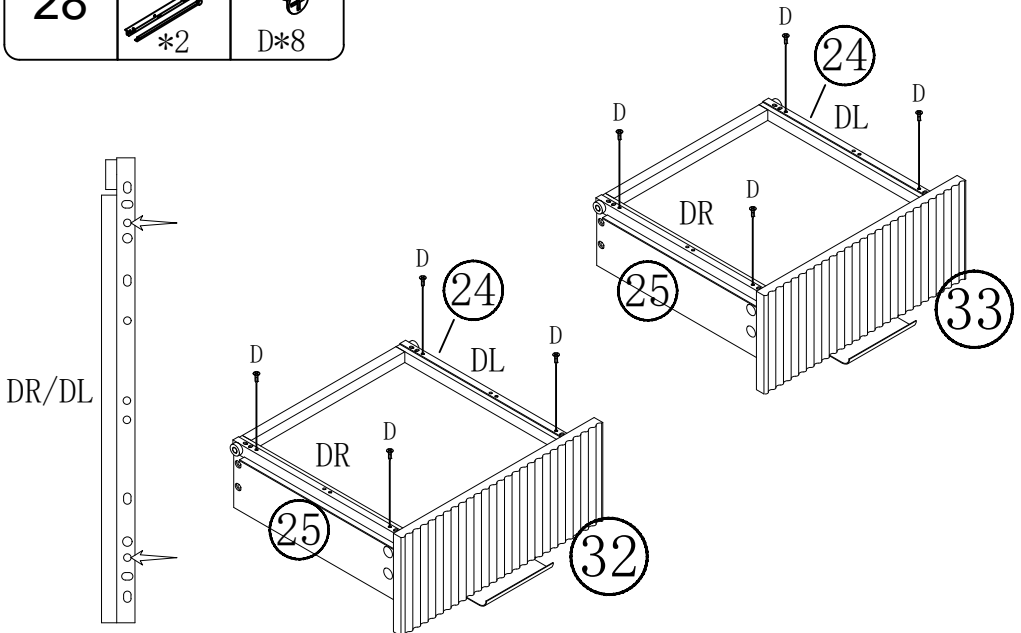

28	 *2	 D*8
----	---	--

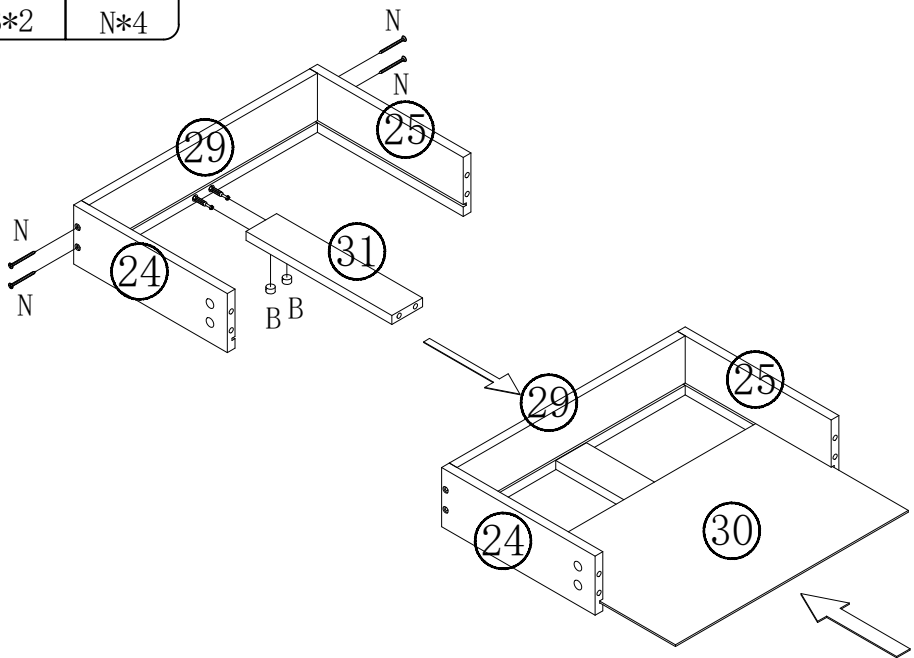

29	 B*2	 N*4
----	---	---



30	 B*6	 F*1	 D*2
----	--	--	--

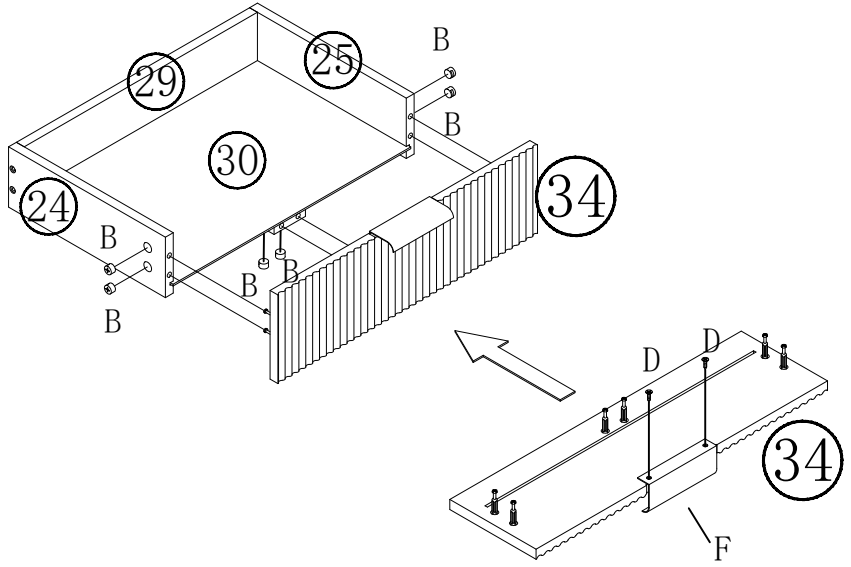

31

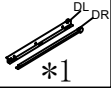

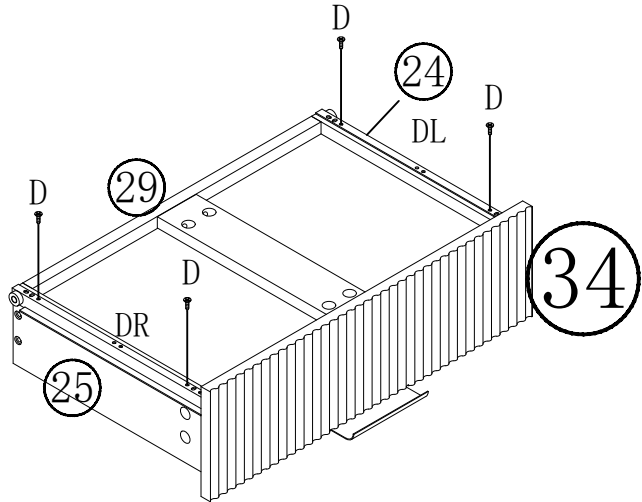
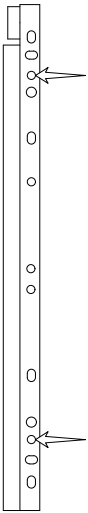

DR/DL



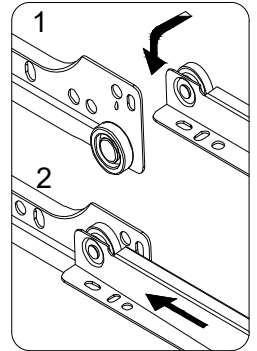
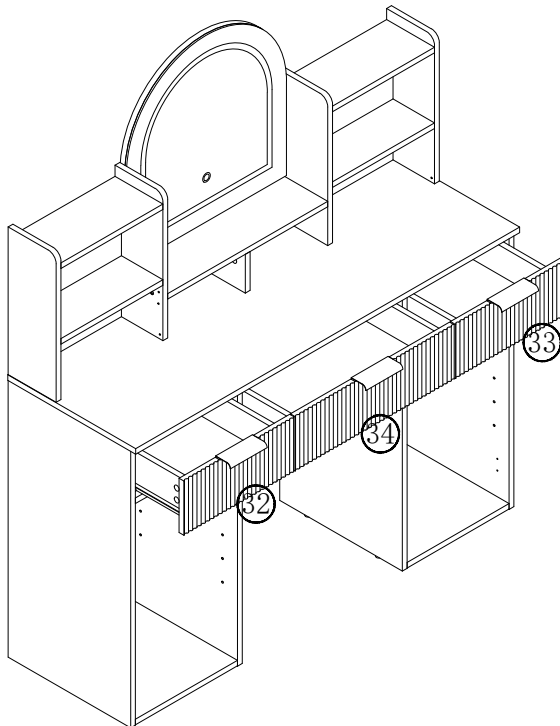



32

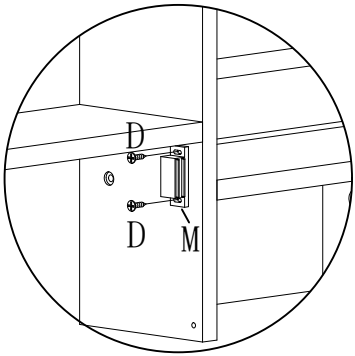
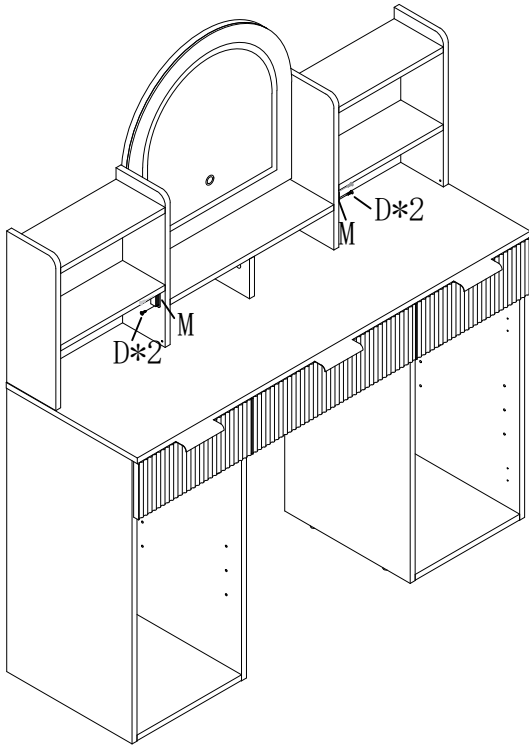

33	 M1	 D*4
	M*2	



34	 M2	 L*4	 F*2	 D*8
	M*2	L*4	F*2	D*8

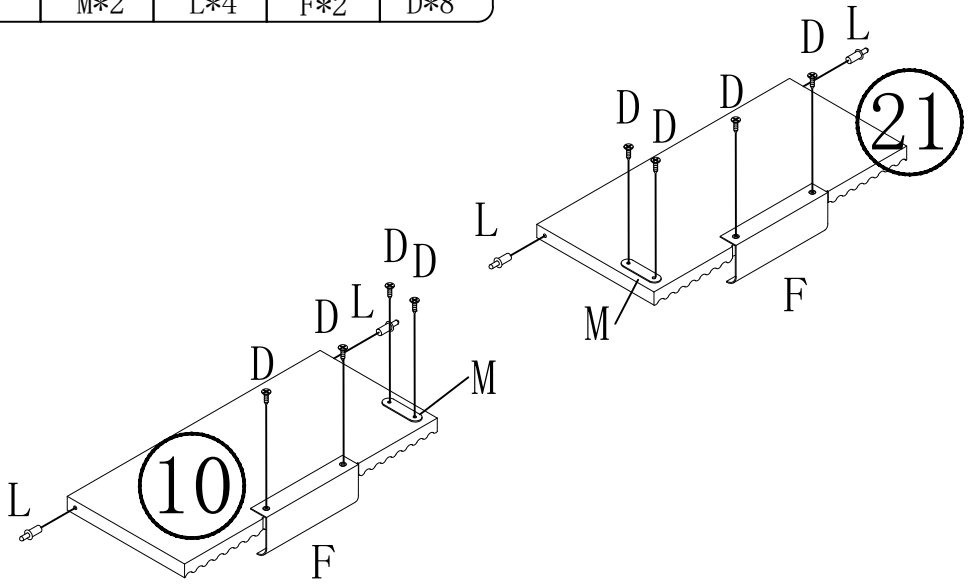

35

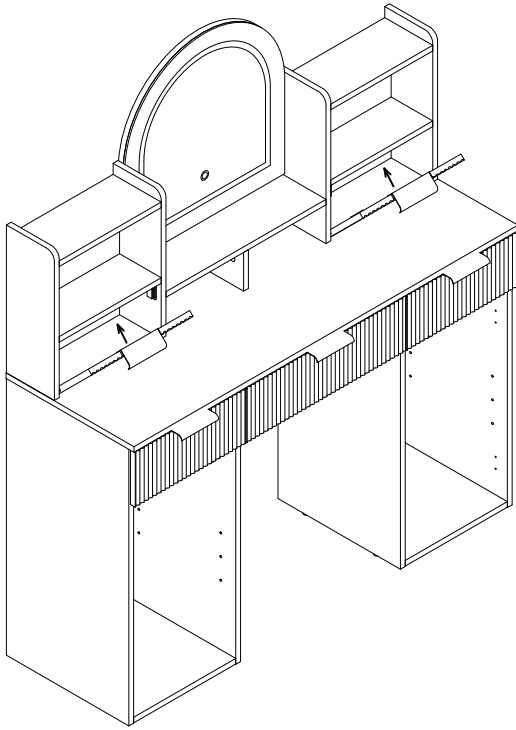
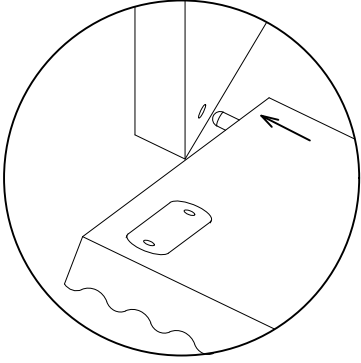

36



I\*8

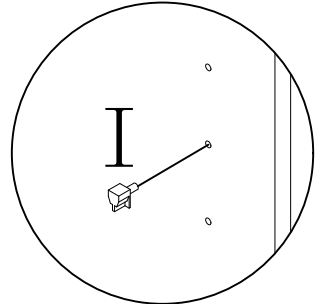
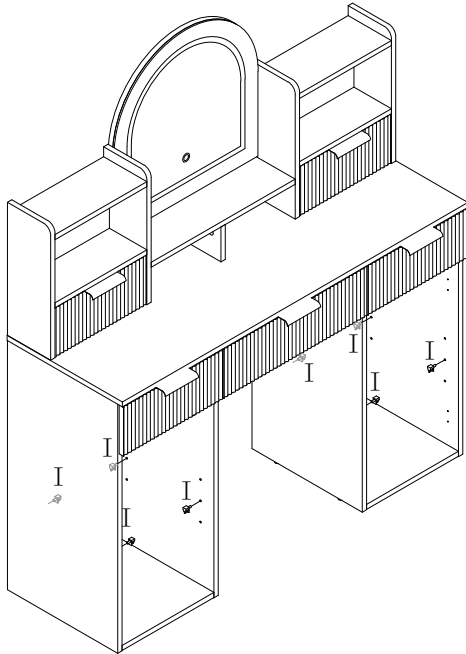

37

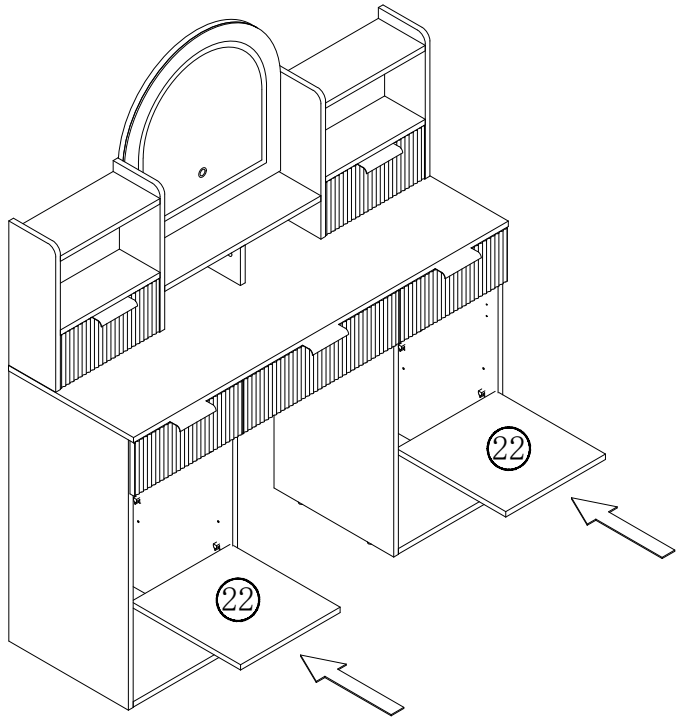

38

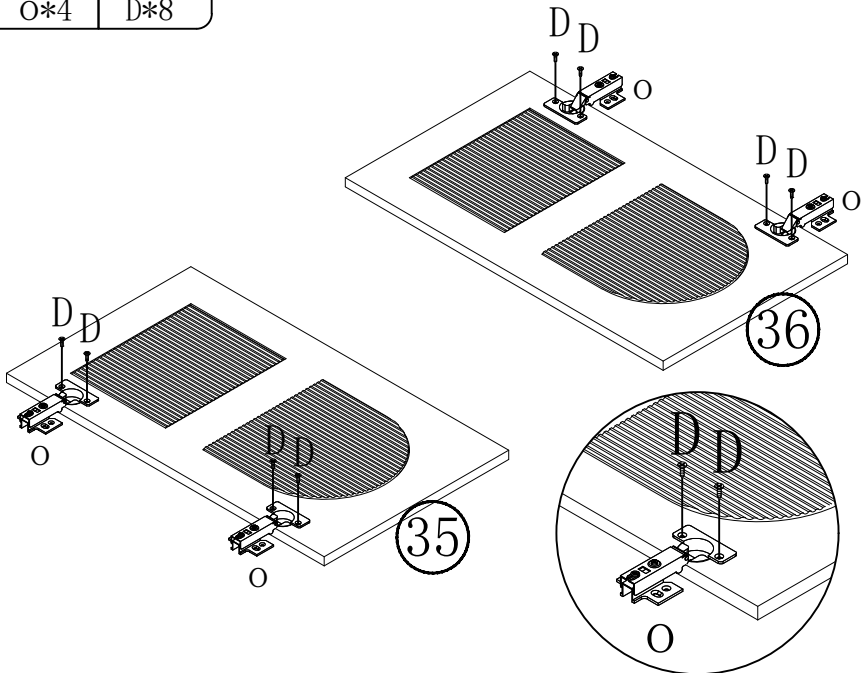

39



D\*16

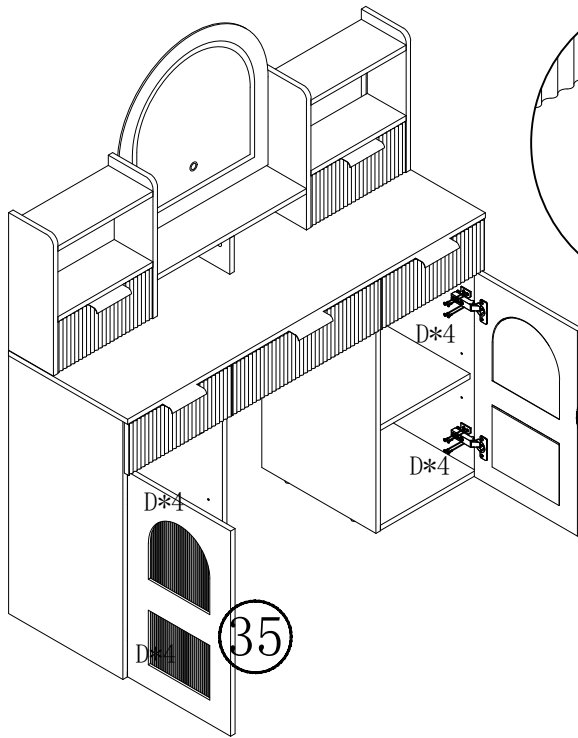

D\*4

39

40

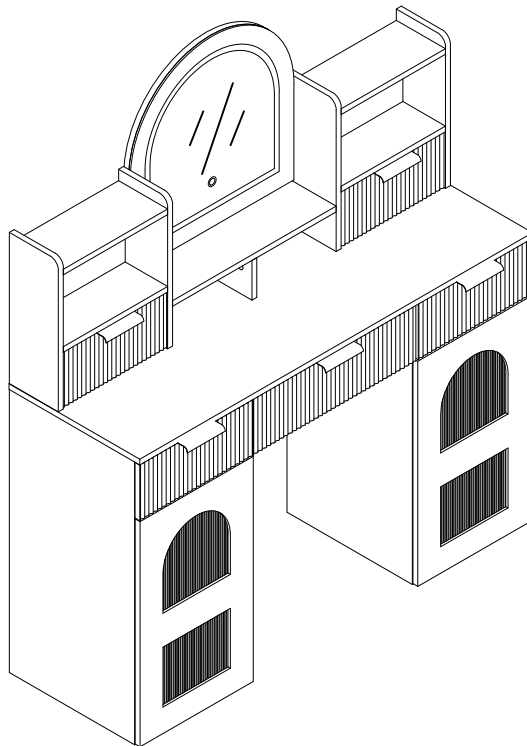

41



P x 67

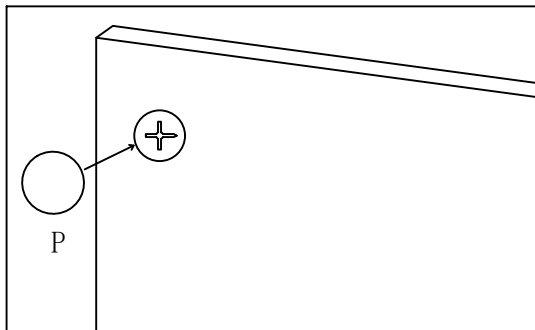

UK: After installing the product, stick the number P on the perforated position

FR: Une fois le produit installé, collez le numéro P à l'endroit où il y a des trous

DE: Nach der Installation des Produkts kleben Sie die Nummer P auf die perforierte Position

IT: Dopo l'installazione del prodotto, fissare il numero P sulla posizione perforata

ES: Después de instalar el producto, pegue el número P en la posición perforada



# Certificate of Compliance

Certificate Number: ZHT-241016118C

**Certificate's Holder** : Shenzhen Lanling Optoelectronics Technology Co., Ltd  
**Zertifikatsinhaber** : 511-G5, Building C, No. 101 Fukang Road, Henggang Community, Henggang Street, Longgang District, Shenzhen City, Guangdong Province

**Manufacturer** : Shenzhen Lanling Optoelectronics Technology Co., Ltd  
**Hersteller** : 511-G5, Building C, No. 101 Fukang Road, Henggang Community, Henggang Street, Longgang District, Shenzhen City, Guangdong Province

**Trade Mark** : /  
**Warenzeichen** : /

**Product** : LED Strip  
**Produkt** : LED Strip

**Model(s)** : LED2835X34  
**Bezeichnung** : LED5050X18, LED5050X30, LED5050X48, LED5050X60, LED5050X72, LED5050X90, LED5050X120, LED2835X30, LED2835X60, LED2835X120, LED2835X180, LED2835X240, LED2835X42, LED2835X84, LED3528X120, LED3528X240, LED5730X60, LED5730X72, LED5730X84, LED3535X60, LED3535X120

**Test Standard** : IEC 62321-3-1:2013, IEC 62321-5:2013, IEC 62321-4:2013+A1:2017,  
**Geprüft nach** : IEC 62321-7-1:2015, IEC 62321-7-2: 2017, IEC 62321-6:2015, IEC 62321-8:2017

**Test Report No.** : ZHT-241016118R  
**Bericht Nr** : ZHT-241016118R

The EUT described above has been consolidated by us and found in compliance with the council RoHS Directive 2011/65/EU Annex II amending Annex (EU)2015/863 and amending Annex (EU)2017/2102. It is possible to use CE marking to demonstrate the compliance with this RoHS Directive. It is only valid in connection with the test report.

# RoHS



The information of the certificate can be checked through [www.zht-lab.cn](http://www.zht-lab.cn).

The ROHS mark which is shown on the certificate can only be used under the conditions that the products complete with all of the relevant Directives of ROHS Declaration of Conformity. The Manufacturer should be responsible for the internal production control so that the products complied with the essential requirements of the above mentioned Directive(s). Certificate holder must notify all changes to the original certification laboratory of Guangdong Zhonghan Testing Technology Co., Ltd.



Guangdong Zhonghan Testing Technology Co., Ltd.

Address: Room 104, Building 1, Yibaolai Industrial Park, Qiaotou Community, Fuhai Street, Bao'an District, Shenzhen, Guangdong, China

Tel.: +86-755-27782934 [Http://www.zht-lab.cn](http://www.zht-lab.cn) E-mail: [admin@zht-lab.cn](mailto:admin@zht-lab.cn)

Shenzhen ZKT Technology Co., Ltd.  
 1/F, No. 101, Building B, No. 6, Tangwei Community Industrial Avenue,  
 Fuhai Street, Bao'an District, Shenzhen, China



# Certificate of Compliance

Certificate Number: ZKT-250902L21450C

**Certificate's Holder** : Shenzhen Lanling Optoelectronics Technology Co., Ltd  
 511-G5, Building C, No. 101 Fukang Road, Henggang Community,  
 Henggang Street, Longgang District, Shenzhen City, Guangdong  
 Province

**Manufacturer** : Shenzhen Lanling Optoelectronics Technology Co., Ltd  
 511-G5, Building C, No. 101 Fukang Road, Henggang Community,  
 Henggang Street, Longgang District, Shenzhen City, Guangdong  
 Province

**Trade Mark** : /

**Product** : LED Strip

**Model(s)** : CWG-5050RGB-60D-5v  
 LED5050X18, LED5050X30, LED5050X48, LED5050X60, LED5050X72,  
 LED5050X90, LED5050X120, LED2835X30, LED2835X60,  
 LED2835X120, LED2835X180, LED2835X240, LED3528X30,  
 LED3528X60, LED3528X120, LED3528X240, LED5730X60,  
 LED5730X72, LED5730X84, LED3535X60, LED3535X120

**Test Standard** : EN IEC 62031:2020+A11:2021

This Attestation of Compliance is issued on a voluntary basis for electrical equipment below the voltage limits of Low Voltage Directive 2014/35/EU. The essential requirements are fulfilled accordingly based on the technical specifications applicable at the time of issuance. See also notes overleaf. It is only valid in connection with the test report number: ZKT-250902L21450S.



This Certificate of Conformity is based on single evaluation of the submitted sample(s) of the above mentioned product. It does not imply an assessment of the whole product and relevant Directives to be observed.

Shenzhen ZKT Technology Co., Ltd.  
 1/F, No. 101, Building B, No. 6, Tangwei Community Industrial Avenue,  
 Fuhai Street, Bao'an District, Shenzhen, China



# Certificate of Compliance

Certificate Number: ZKT-250902L21449C

**Certificate's Holder** : Shenzhen Lanling Optoelectronics Technology Co., Ltd  
 511-G5, Building C, No. 101 Fukang Road, Henggang Community,  
 Henggang Street, Longgang District, Shenzhen City, Guangdong  
 Province

**Manufacturer** : Shenzhen Lanling Optoelectronics Technology Co., Ltd  
 511-G5, Building C, No. 101 Fukang Road, Henggang Community,  
 Henggang Street, Longgang District, Shenzhen City, Guangdong  
 Province

**Trade Mark** : /

**Product** : LED Strip

**Model(s)** : CWG-5050RGB-60D-5V  
 LED5050X18, LED5050X30, LED5050X48, LED5050X72, LED5050X90,  
 LED5050X120, LED2835X30, LED2835X60, LED2835X120,  
 LED2835X180, LED2835X240, LED3528X30, LED3528X60,  
 LED3528X120, LED3528X240, LED5730X60, LED5730X72, LED5730X84,  
 LED3535X60, LED3535X120

**Test Standard** : EN IEC 55015:2019+A11:2020  
 EN IEC 61000-3-2:2019 + A1:2021 + A2:2024  
 EN 61000-3-3:2013 + A1:2019 + A2:2021  
 EN IEC 61547:2023

This Attestation of Compliance is issued on a voluntary basis for electrical equipment below the voltage limits of EMC Directive 2014/30/EU. The essential requirements are fulfilled accordingly based on the technical specifications applicable at the time of issuance. See also notes overleaf. It is only valid in connection with the test report number: ZKT-250902L21449E.



This Certificate of Conformity is based on single evaluation of the submitted sample(s) of the above mentioned product. It does not imply an assessment of the whole product and relevant Directives to be observed.

Shenzhen ZKT Technology Co., Ltd.  
 1/F, No. 101, Building B, No. 6, Tangwei Community Industrial Avenue,  
 Fuhai Street, Bao'an District, Shenzhen, China



# Certificate of Compliance

Certificate Number: ZKT-260105L0127C

**Certificate's Holder** : Shenzhen Lanling Optoelectronics Technology Co., Ltd  
 511-G5, Building C, No. 101 Fukang Road, Henggang Community, Henggang Street, Longgang District, Shenzhen City, Guangdong Province

**Manufacturer** : Shenzhen Lanling Optoelectronics Technology Co., Ltd  
 511-G5, Building C, No. 101 Fukang Road, Henggang Community, Henggang Street, Longgang District, Shenzhen City, Guangdong Province

**Trade Mark** : /

**Product** : Controller strip lights

**Model(s)** : YH-358

REQUIREMENT	STANDARD	Report No.
Art.3.1(a) Safety	EN 60598-2-21:2015 EN IEC 60598-1:2024+A11:2024 EN IEC 62031:2020+A11:2021	ZKT-260105L0128S
Art.3.1(a) Health	EN 62479:2010 EN 50663:2017	ZKT-260105L0127E-3
Art.3.1(b) EMC	ETSI EN 301 489-1 V2.2.3 (2019-11) ETSI EN 301 489-17 V3.3.1 (2024-09) EN IEC 61000-3-2:2019 + A1:2021 + A2:2024 EN 61000-3-3:2013 + A1:2019 + A2:2021	ZKT-260105L0127E-1
Art.3.2 Radio	ETSI EN 300 328 V2.2.2 (2019-07)	ZKT-260105L0127E-2

This Attestation of Compliance is issued on for electrical equipment below the voltage limits of Radio Equipment Directive (RED) 2014/53/EU. The essential requirement are fulfilled accordingly based on the technical specifications applicable at the time of issuance.



This Certificate of Conformity is based on single evaluation of the submitted sample(s) of the above mentioned product. It does not imply an assessment of the whole product and relevant Directives to be observed.